



EVAL-1000047

Evaluation Board for AeroQor Series of Isolated PFC Converters

Summary

SynQor has developed the EVAL-1000047, to facilitate testing of our AeroQor isolated PFC converter and its associated AC line filter.



Introduction

This application note is a guide to the features, schematic, component placement, and Bill of Material for this evaluation board. The applicable converter modules are:

Table 1: Applicable converter and filter modules

Product Family	Filter Module	Isolated Power Factor Correction Module
AeroQor	ACF-U-230-HP	APFIC-U-XX[R,D]-FT
AeroQor	ACF-U-230-HT	APFIC-U-XX[R,D]-FG

Contents

- Section 1 – Converter Description 2
- Section 2 – Evaluation Board Block Diagram 2
- Section 3 – Schematic 3
- Section 4 – Component Placement 4
- Section 5 – Input , Status/Monitor/Control, Hold-up, and Output Connections . . 5
- Section 7 – Basic Operation Instructions 5
- Section 6 – Switches 10
- Section 7 – Basic Operation Operating Instructions 10
- Section 8 – Paralleling 11
- Appendix A – Bill of Materials (BOM). 13

This evaluation board and schematic are intended for demonstration purposes only and no guarantees are made for standards compliance.

Shock Warning: There are areas of this evaluation board that have exposed access to hazardous high voltage levels. Exercise caution to avoid contact with those voltages. Also note that the evaluation board may retain high voltage temporarily after input power has been removed. Exercise caution when handling.

Thermal Considerations: When testing converters on an evaluation board, ensure adequate cooling. Apply cooling air with a fan blowing across the converter or across a heatsink attached to the converter. Monitor the converter temperature to ensure it doesn't exceed the maximum rated temperature per the datasheet specification.

Sockets: Please note that this evaluation board uses sockets to provide the option of testing multiple converters. For longer-term testing, thermal testing, and permanent installations use soldered connections.

Section 1 – Converter Description

SynQor has developed an isolated Power Factor Correction (PFC) modules to meet the specific Civil Aviation power requirements. All isolated PFCs are high power, high efficiency AC-DC converters. They operate from a universal AC input and generate an isolated and regulated output. Used in conjunction with a hold-up capacitor, SynQor’s isolated PFCs and their respective AC line filters draw a nearly perfect sinusoidal current ($PF > 0.99$) from a single-phase AC input.

The hold-up capacitor has a typical voltage of 400 Vdc and performs two functions:

1. It handles the cyclical imbalance between the flow of energy drawn from the AC source and the flow of energy delivered to the load. In doing so, the voltage across the hold-up capacitor has a ripple at a frequency twice that of the AC source voltage (e.g. 120 Hz for a 60 Hz input). The larger the hold-up capacitor, or the higher the frequency of the AC source, the smaller this ripple will be.
2. It provides a source of energy so that the APFIC can continue to deliver load power during a temporary brownout or dropout of the AC source. The larger the hold-up capacitor, the longer it can provide this energy. Often it will be made large enough to allow the load to be gracefully shutdown after the AC source has been outside of its normal range for a set amount of time. A typical “hold-up time” would be in the 20 ms range for a 50/60 Hz system.

Section 2 – Evaluation Board Block Diagram

The EVAL-1000047 board is designed to facilitate the testing of SynQor’s Isolated PFCs and their associated AC line filters. Because each of the three sectors have distinct requirements, the EVAL-1000047 is designed to accommodate different components depending on the application. Figure 1 shows a typical connection diagram for a Civil Aviation application.

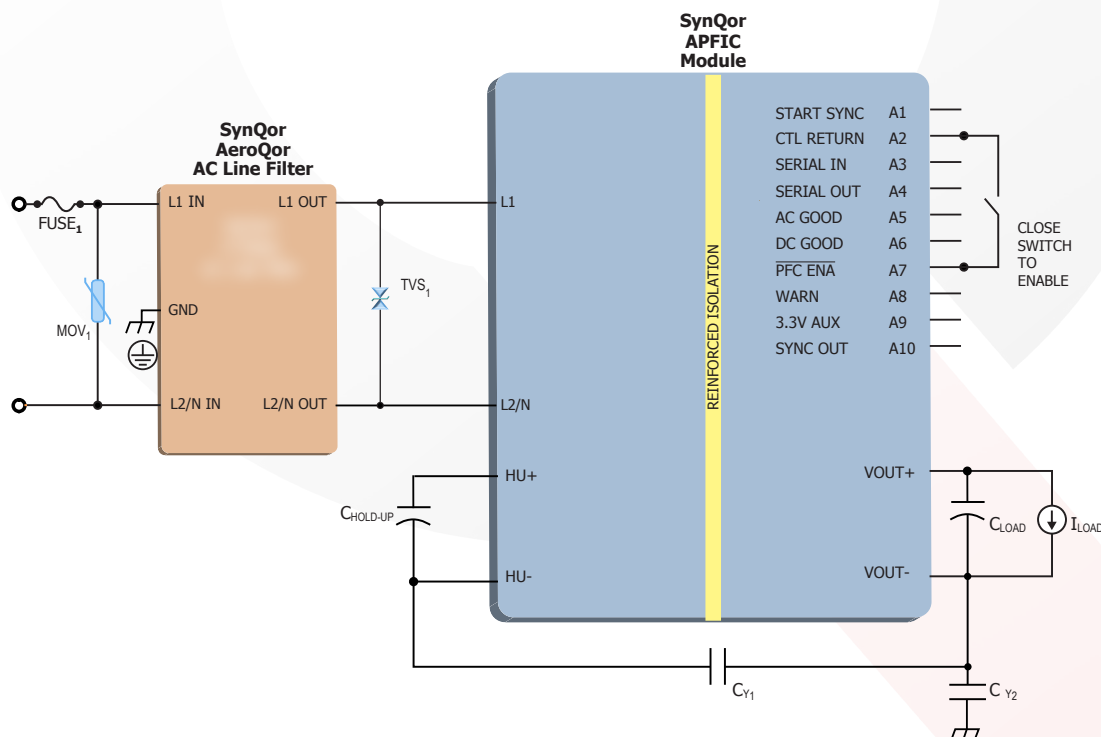

Fuse 1: 250VAC, 12.5A; Littelfuse 021612.5MXEP
 MOV1: 300VAC, 60J; EPCOS S10K300E2
 TVS1: 400V, 3J; two VISHAY 1.5KE200CA devices connected in series
 CHoldup: One 450V, 100 μ F; United Chemi-Con EKXG451ELL101MM40S
 CY1: 10nF equivalence (Two paralleled banks of 2x 10nF capacitors in series), Knowles Syfer 2220YA250103KXTB16
 CY2: 10nF, 250VAC; Knowles Syfer 2220YA250103KXTB16

Figure 1: Typical AeroQor connection diagram

Section 3 – Schematic

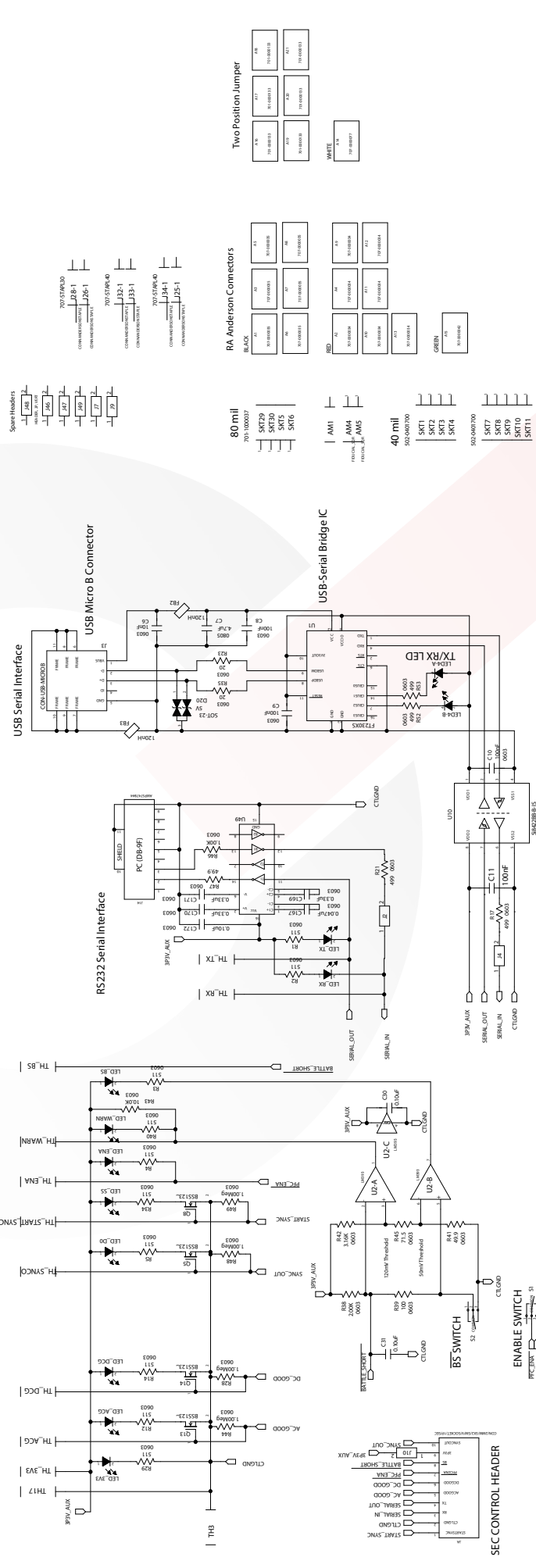
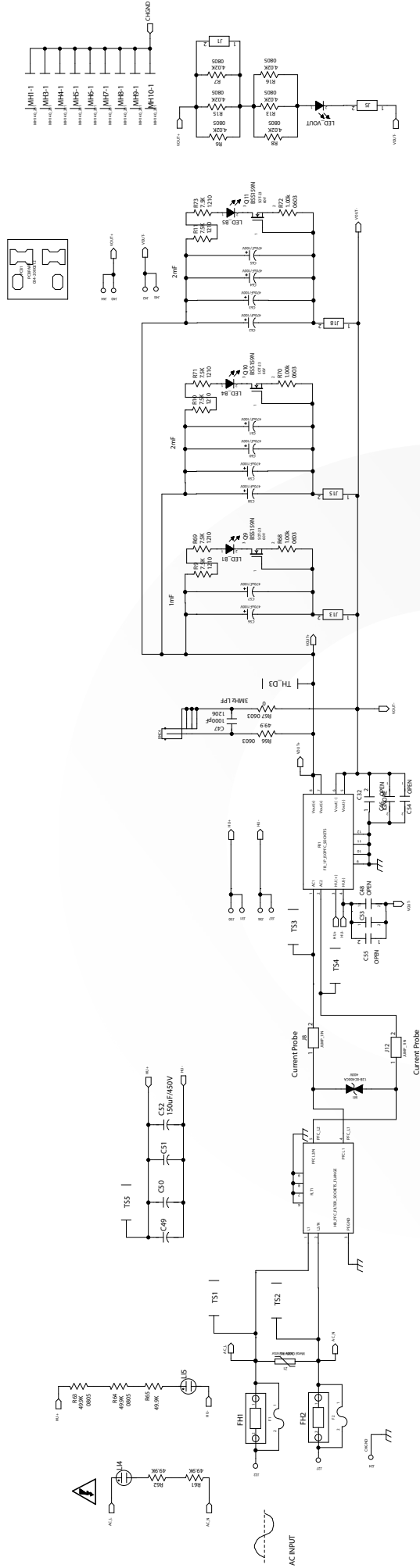

Figure 2: EVAL-1000047 Schematic Diagram

Section 4 – Component Placement

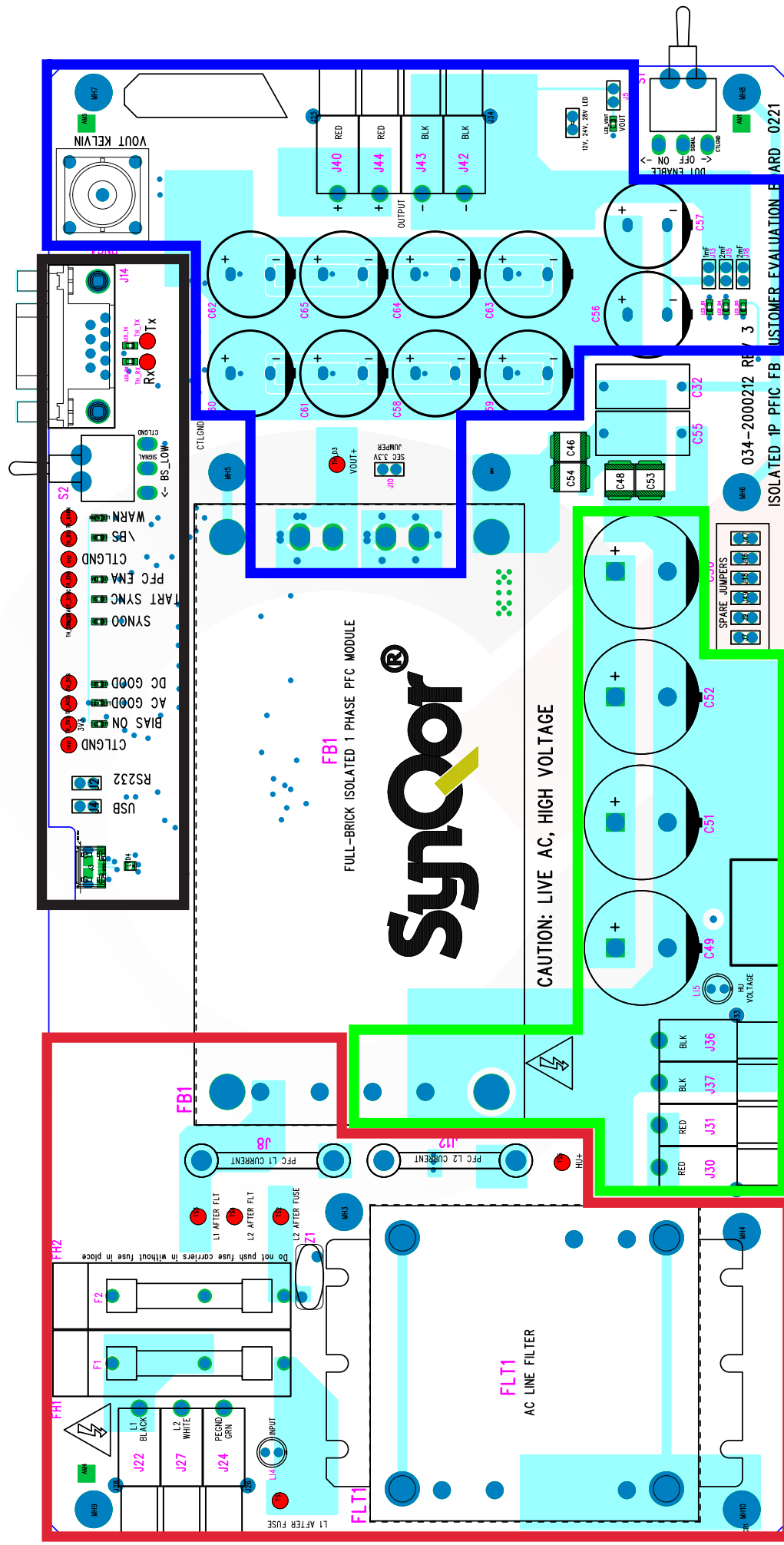

Figure 3: EVAL-1000047 Board Component Placement

Section 5 – Input , Status/Monitor/Control, Hold-up, and Output Connections

The isolated PFC evaluation board is split into four different regions. The different regions are: input, status and monitoring, hold-up and output. The AC input region is shown in red in Figure 3 and is called Region 1. Similarly, the Status/Monitor/Control section, Region 2, is shown in black, the hold-up section, Region 3, is shown in green and the DC isolated output section, Region 4, is shown in blue in Figure 3. Each of the four regions have different voltage waveforms which can be either isolated or non-isolated. Care should be taken when connecting an oscilloscope to any of the non-isolated regions. Using an inappropriate probe with no isolation characteristics could lead to improper measurements and could damage both the evaluation board and the oscilloscope or measuring device.

Region 1: AC Input (Red)

CAUTION: All the signals in Region 1 (Red) have LIVE input voltages and are referenced to the AC input voltage. All the test points in Region 1 are labeled in red indicating that differential scope probes must be used when probing these signals.

Input power is applied through standard Anderson Power-block connectors J22, J27 and J24, see Table 2. Phases L1 and L2/N are clearly labeled. L2/N can either be connected to a line voltage, to neutral or ground if applicable. The LI4 lamp lights up when voltage is present across the input terminals of the board (Table 7). Note that the lamp could light up even if the input voltage is not within the specified range of the isolated PFC. Tables 3 and 4 list the fuses, Transient Voltage Suppressors (TVS) and Metal Oxide Varistor (MOV) device specifications along with suggested part numbers.

AC Input - Scope Probing Options

- AC Line-Line Input voltages can be monitored with differential scope probes attached between the test points labeled TS1-TS2 (Table 5). Note that if the AC voltage source is isolated, voltage between these test points will also be isolated. If the AC voltage source is not isolated, voltage between these test points will also be non-isolated. Also note that not using differential probes to conduct these measurements could damage some of the components in the board and the oscilloscope.
- AC Input voltages at the PFC module can be monitored with differential scope probes attached between TS3 and TS4 (Table 4). Note that if the AC voltage source is isolated, voltage between these test points will also be isolated. If the AC voltage source is not isolated, voltage between these test points will also be non-isolated. Also note that not using differential probes to conduct these measurements could damage some of the components in the board and the oscilloscope.
- AC Input Phase currents can be monitored by installing current loops J8 and J12 and using an isolated current probe to measure each of the currents (Table 6).

Table 2: Input Power Connector J16

Connector Terminal #	Input Terminal Name	Part Description
J22	Line 1 (L1)	Anderson PP45 connector Black
J27	Line 2 / Neutral (L2/N)	Anderson PP45 connector White
J24	Earth Ground (PE GND)	Anderson PP45 connector Green

Table 3: Fuses

Reference Description	Value	Package	Part Number
F1, F2	15A	1/4 x 1-1/4	Fast Acting Ceramic Fuse

Table 4: TVS and MOV Devices

Reference Description	Value	Package	Part Number
M1	300V AC	Radial, 10mm disc	Metal Oxide Varistor, Epcos, S10K300E2
TVS1, TVS2	400V	Through Hole	Vishay 1.5KE200E2

The evaluation board includes a protective MOV device across the two input lines. These are placed to absorb energy from potential transients that may be present on the AC line. The MOV devices are 300VAC, 60J EPCOS S10K300E2 (Table 5).

Line to Line TVSs are included following the filter output pins to clamp the peak voltage seen by the PFC module when stimulated by a high voltage input transient. The TVS devices are two 400V, 3J Vishay 1.5KE200CA devices (Table 5).

Table 5: Evaluation board high voltage test points (Non-Isolated)

Reference Designator	Test Point Signal Names	Test Point Color
TS1	L1 After Fuse	Red
TS2	L2 After Fuse	Red
TS3	L1 After Filter	Red
TS4	L2 After Filter	Red
TS5	HU+	Red
TS6	HU-	Red

Table 6: Evaluation board high current sensing loops jumpers

Reference Designator	Current Sense Loops	Isolation
J8	L1 Input current to PFIC	Non-Isolated
J12	L2 Input current to PFIC	Non-Isolated

Table 7: Input Voltage Lamps

Reference Designator	LED Signal Names	Region
L14	Input Line Voltage	Red

Region 2: Status/Monitor/Control (Black)

All the signals in Region 2 which is the black region are reference to CTL_RETURN which is fully isolated from both the AC Input and the DC Output regions/terminals. The test points here are black indicating that standard scope probes may be utilized without risk of damaging the unit or the oscilloscope (Table 8). For information regarding each of the features consult the application section of the isolated PFC datasheet.

There also are several different test points on the Status/Monitor/Control section of the evaluation board that can be visually monitored via LEDs (Table 9) or probed at the adjacent test points described below (Table 8).

Table 8: Evaluation board low voltage isolated test points

Reference Designator	Test Point Signal Names	Test Point Color
TH3	Ground	Black
TH17	CTL_RETURN	Black
TH_3V3	3.3V Bias	Black
TH_ACG	AC_GOOD	Black
TH_BS	N/A	
TH_D3	VOUT+	Black
TH_DCG	DC_GOOD	Black
TH_ENA	PFC_ENA	Black
TH_RX	SERIAL_IN	Black
TH_START_SYN	START_SYNC	Black
TH_SYNCO	SYNC_OUT	Black
TH_TX	SERIAL_OUT	Black
TH_WARN	WARN	Black

Table 9: Evaluation board LEDs

Reference Designator	Test Point Signal Names	Test Point Color
LED4-A	TX	Black
LED4-B	RX	Black
LED_3V3	3.3V Bias Supply	Black
LED_ACG	AC_GOOD	Black
LED_BS	N/A	
LED_DO	SYNC_OUT	Black
LED_DCG	DC_GOOD	Black
LED_ENA	PFC_ENA	Black
LED_RX	SERIAL_IN	Black
LED_TX	SERIAL_OUT	Black
LED_SS	START_SYNC	Black
LED_VOUT	VOUT	Blue
LED_WARN	WARN	Black

Serial Communications Interface

To communicate with the evaluation board kit, a DB9 Male to RS-232 cable can be used. The DB9 allows for a direct connection from a computer to the evaluation's board RS-232 port.

The EVAL Board is equipped with an RS-232 serial port and a USB serial interface. By factory default, the USB serial interface is enabled for serial communication. If the user would like to enable the RS-232 port, the user will need to remove the jumper J4 and move it to J2. Both ports cannot be configured to run simultaneously in the same EVAL Board.

Terminal interface has to be configured to these parameters: 9600 baud, 8 data bits, no parity, and one stop bit. Set the terminal emulator to send both a line-feed and a carriage return. The PFIC does not echo any characters sent to the unit. In order to see the characters being sent to the module in your terminal emulator window, enable the echo feature on your terminal emulator. Commands can be sent, and output viewed, with any standard serial terminal emulator.

To communicate with the Evaluation board via USB interface, a USB 2.0 Micro B male cable is needed (Table 10).

Table 10: Suggested RS-232 interface cable

Manufacturer	Part Number	Description
Assmann WSW Components	AE1324-ND	Cable DB9/25Male

USB Serial Communications Interface

To communicate with the evaluation board, you will first have to install the appropriate USB driver. The FT230XS driver can be found at [FTDI chip web site](#). Once the USB drivers are properly installed, a new serial port object should become available for application use. Under Windows, the serial port should become visible from the Windows Device Manager in the “Ports (COM & LPT)” category, and should be assigned a new COMx name (where x is a number, ex: “COM2”). The exact COMx number assigned to the hardware will depend in part on how many COMx based hardware devices have previously been connected to the machine, as each new hardware instance must be assigned a new and unique number to avoid potential conflicts.

If a machine currently has more than one COMx based hardware device attached to the machine, multiple COMx entries (but different numbers, e.g., COM1 and COM2) may exist in the Windows Device Manager “Ports (COM & LPT)” category, and it may not be clear which COMx port number is specifically associated with the FT230X device. If this occurs, the COMx number can be manually identified by temporarily detaching the USB connection to the FT230X while watching the Windows Device Manager to identify which device entry disappears (and subsequently re-appears in the list upon re-attaching the FT230X).

Once the COMx port number assigned to the FT230X is known, any conventional serial port terminal program can be used to open/close/read/write to the COMx port. To communicate with the evaluation board, a USB Micro-B Male cable can be used for a direct connection to the USB port.

The evaluation’s board USB serial port uses 9600 baud, 8 data bits, no parity, and one stop bit. Commands can be sent, and output viewed, with any standard terminal emulator.

Please refer to the application note [SynQor Single-Phase PFC Full-brick Terminal Commands](#) for information regarding the communications standards and parameters available for monitoring.

Region 3: Hold-up (Green)

All DC voltages on the hold-up region (Region 3 which is green in Figure 3) are non-isolated and the reference is one diode drop away from either L1 or L2/N input rails depending where the input waveform is in its line cycle. The HU- rail is the return terminal of the boost stage. As a result, the HU- voltage is typically one diode drop from L2/N if L1 is greater than L2/N and it is one diode drop away from L1 if L2/N is greater than L1. The HU+ terminal is the forward rail of the boost converter. The hold-up, HU+ and HU-, terminals are used to charge the hold-up capacitors. The isolated PFC module requires at least 100uF of hold-up capacitance.

The hold-up capacitor handles the cyclical imbalance between the flow of energy drawn from the AC source and the flow of energy delivered to the load. This energy imbalance has a cyclical frequency twice that of the AC source voltage (e.g. 120Hz for a 60Hz input). This relatively low frequency makes the hold-up capacitor relatively large. Another purpose of the hold-up capacitor is to be a source of energy so that the output can continue to deliver load power during a temporary brownout or dropout of the AC source. A typical power supply will have sufficient hold-up capacitor to give a “hold-up time” in the 20ms range, but longer times can be achieved with yet more hold-up capacitance.

Additional hold-up capacitance can be added through Anderson Power-block connectors J30 and J31 for HU+ rail and J36 and J37 for the HU- rail (Table 11).

The LI5 lamp will light up to indicate that there is voltage present across hold-up terminals. Note that the lamp might continue to be lit even if the hold-up voltage is well below the typical hold-up voltage value of 400Vdc. This is specially the case during startup, shutdown and input drop-off transients. You should assume that while the lamp is lit, there could be a dangerous voltage present across the hold-up terminals.

Table 11: External Hold-Up Connectors

Connector Terminal #	Hold-Up Terminal Name	Part Description
J30, J31 Labeled “+”	Positive Hold-Up Output (Hu+)	Anderson PP45 connector Red
J36, J37 Labeled “-”	Negative Hold-Up Output (Hu-)	Anderson PP45 connector Black

DC Hold-up - Scope Probing Options

- Use either connector J30 or J31 to connect the positive lead of the differential probe. Use either connector J36 or J37 to connect the negative lead of the differential probe. Note that if the AC voltage source is isolated, voltage between these test points will also be isolated. If the AC voltage source is not isolated, voltage between these test points will also be non-isolated. Also note that not using differential probes to conduct these measurements could damage some of the components in the board and the oscilloscope. The HU- reference is not at the same voltage potential as either input line voltage.

Table 12: Hold-Up Lamp

Reference Designator	LED Signal Name	Region
LI5	Hold-Up Voltage	Green

Region 4: DC Output (Blue)

All DC voltages on the DC output region (Region 4 which is blue in Figure 3) are referenced to the isolated output of the PFC. The isolated output is delivered to external loads through the MAIN OUTPUT connectors J40/J44 (Vout+) and J42/J43 (Vout-). See Table 13.

The “LED_VOUT” (Table 14) will light up while there is voltage present across the input terminals. Because the evaluation board can house different isolated PFCs with different output voltages (12 Vdc-55 Vdc), the J1 jumper has been included which can short R5, R7, R15 so that the LED can shine brighter when low output voltage modules are tested. We recommend that you add the J1 jumper, if the isolated PFC delivers either 12, 24 or 28 Vdc. The J1 jumper should not be populated if the isolated PFC module delivers an output voltage higher than 28 Vdc across the output terminals.

Table 13: Output Power Connectors

Connector Terminal #	Output Terminal Name	Part Description
J40, J44 Labeled “+”	Positive Output (+Vout)	Anderson PP45 connector Red
J42, J43 Labeled “-”	Negative Output (-Vout)	Anderson PP45 connector Black

Table 14: Output Related LEDs

Reference Designator	LED Signal Name	Region
LED_VOUT	VOUT	Blue
LED_B1	Output Capacitor Bank 1	Blue
LED_B4	Output Capacitor Bank 2	Blue
LED_B5	Output Capacitor Bank 3	Blue

DC Output - Scope Probing Options

- BNC4 connector labeled Vout Kelvin provides a Kelvin connection for monitoring Vout during testing.
- Output current can be measured using a standard current probe clamped to any of the output load lines.

Capacitor Banks on the Evaluation Board

Because of the different isolated PFC output voltage options, there are three different capacitor banks available. The first bank adds 1mF of output capacitance across the output terminals. Banks 2 and 3 each add 2mF of output capacitance across the output. The total output capacitance depends on which jumpers are connected. The total output capacitance can range from 0μF to 5mF. We recommend that you run the module with at least 600μF of output capacitance. External output capacitance can be added through the J40/J44 Vout + and the J42/J43 Vout- connectors.

The EVAL Board comes with three user selectable capacitor banks. Each bank can be individually connected (or disconnected) from the DC Output using the two pin jumpers J13, J15 and J18. A LED near each jumper indicates if the capacitor bank is active or not. Note that at least one string of the capacitors must remain connected at all times. A single capacitor bank is usually enough to stabilize the input system for the PFC module and any downstream DC-DC power converters. Please refer to the applications section of the [datasheet](#) for more details regarding additional output capacitance to the system.

Table 15: Output Capacitor Bank Jumpers

Reference Designator	Capacitor Banks	Output Voltage	Bank Capacitance
J13	Output Capacitor Bank 1	12-55 Vdc	1mF
J15	Output Capacitor Bank 2	12-55 Vdc	2mF
J18	Output Capacitor Bank 3	12-55 Vdc	2mF

Section 6 – Switches

Description of Switches

Enable On/Off Switch

Toggling S1 switch to the ON position enables the isolated PFC converter. Toggling S1 switch to the OFF position disables the isolated PFC converter.

Battle Short Switch

Feature not available in AeroQor product.

Section 7 – Basic Operation Operating Instructions

Apply the single-phase input, 85-264 Vrms between J22 and J27 in the upper left using a standard Anderson Power Block connector. Lamp L14 indicates the presence of hazardous voltages at the input. Note that the lamp is placed after the fuse. If a fuse is blown it is possible for the lamp to be off even when power is available across the input connectors J22 and J27.

Connect the load to Isolated Output J40/J44 VOUT+ and J42/J43 VOUT-.

Connect additional hold-up capacitance to Hold-Up Output (J13, J15 or J18) if desired. The module should not be run without any output capacitance. We recommend at least of 600μF output bulk capacitance. The board has 3 capacitor banks of 1mF, 2mF and 2mF which can be attached to the output terminals by placing a jumper on J13, J15 or J18. See the datasheet's application section for details.

Use Switch S1 in lower right for enable / disable control.

Section 8 – Paralleling

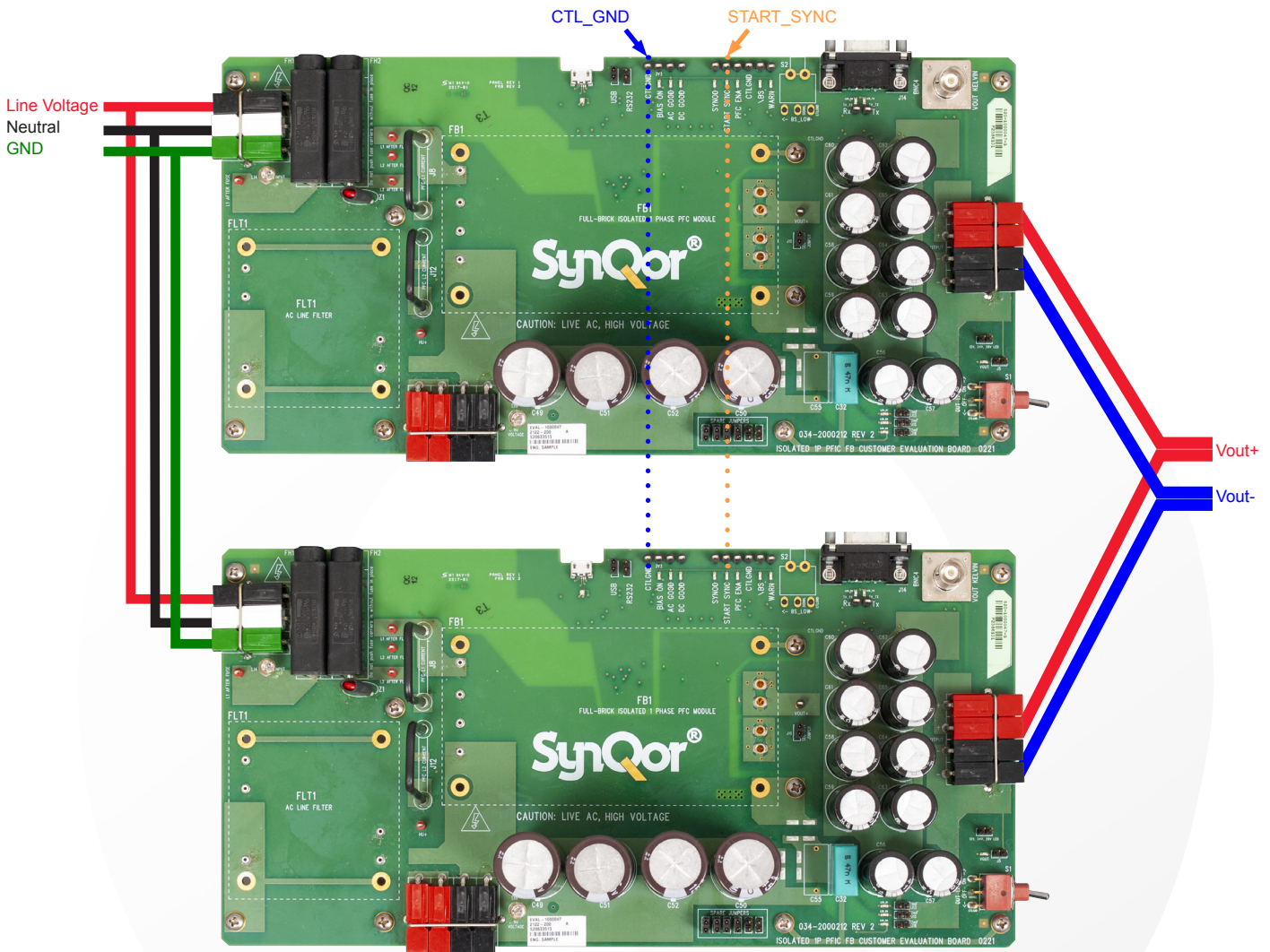

Figure 4: Simplified paralleling diagram of two single-phase evaluation boards with droop share modules powered from a single source.

Output Connections

The single-phase isolated PFC can be purchased with a droop share output option that allows them to be paralleled in order to deliver higher power. To parallel modules in two or more EVAL Boards, the modules must all be the droop type and have the same output voltage rating. The boards can be paralleled by simply attaching the output rails, positive with positive and negative with negative (Figure 4). Converters designed for the droop current-share method reduce their output voltage as the output current increases. At lighter loads the output voltage is higher and at heavier loads it is lower. This is graphically represented as output voltage vs. output current, known as a load-line, that slopes downward as current is increased. Converters connected in parallel using the droop share method will share the current in accordance with how well their load-lines are matched. The advantage of this method of paralleling is the ease of implementation since no share bus or serial communication between modules is required. Cable length and impedance should be kept very close between the output terminals of paralleled modules for optimal load sharing.

To synchronize the startup of the output of multiple boards, interconnect the “START_SYNC” test points and the “CTL_RETURN” test points accordingly between boards (Figure 5). Switch “ON” the Out Enable switch on all boards. We do not recommend that you attempt to parallel the output of more than three boards. The differences in output impedance could hinder the load sharing accuracy of the system. For more information regarding the paralleling of isolated single-phase PFC, please refer to the paralleling section on the isolated PFC [datasheet](#).

Input Connections

The input to paralleled single-phase evaluation boards can be powered from a single source or from different sources. The input ground pin of each board should be tied to the ground system of the source that is powering the unit.

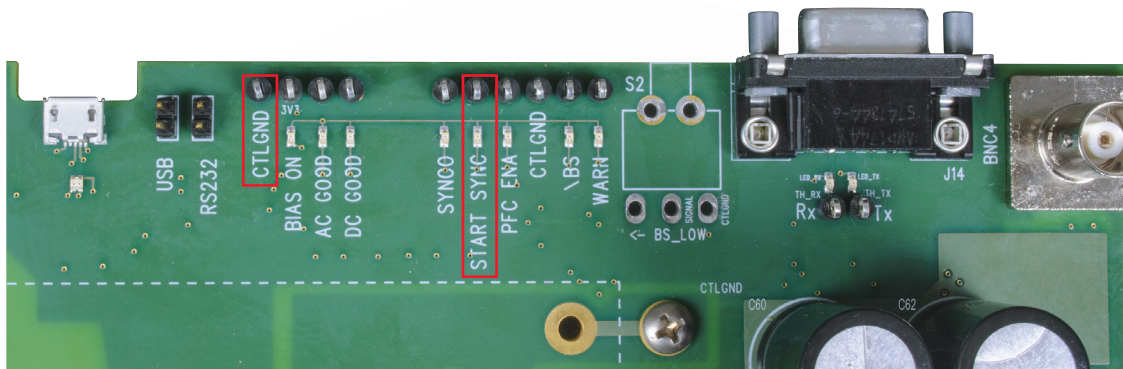

Figure 5: Location of “CTL_RETURN” and “START_SYNC” test points on the evaluation board.

Additional Information

Transient suppression and fusing are included near the input connector to help protect the board and modules. The evaluation board is not intended to be used to pass any Aviation Standards or safety requirements. This evaluation board is intended for demonstration purposes only.

The secondary output of the APFIC is isolated from the AC source. Hold-up voltage is primary referenced and is therefore a hazardous voltage. Care must be taken to avoid contact with primary voltages, as well as with the AC source voltage.

The SPARE JUMPERS section in the board allows designers to keep the jumper in a safe location while not being used. The pins in this section of the board are not connected to any net in the board.

Appendix A – Bill of Materials (BOM)

Ref Des	Value	Package	Description
A1		ANDERSON_HOUSING	Black PP15-45 Anderson Housing
A2		ANDERSON_HOUSING	Red PP15-45 Anderson Housing
A3		ANDERSON_HOUSING	Black PP15-45 Anderson Housing
A4		ANDERSON_HOUSING	Red PP15-45 Anderson Housing
A5		ANDERSON_HOUSING	Black PP15-45 Anderson Housing
A6		ANDERSON_HOUSING	Black PP15-45 Anderson Housing
A7		ANDERSON_HOUSING	Black PP15-45 Anderson Housing
A8		ANDERSON_HOUSING	Black PP15-45 Anderson Housing
A9		ANDERSON_HOUSING	Red PP15-45 Anderson Housing
A10		ANDERSON_HOUSING	Red PP15-45 Anderson Housing
A11		ANDERSON_HOUSING	Red PP15-45 Anderson Housing
A12		ANDERSON_HOUSING	Red PP15-45 Anderson Housing
A13		ANDERSON_HOUSING	Red PP15-45 Anderson Housing
A14		ANDERSON_HOUSING	White PP15-45 Anderson Housing
A15		ANDERSON_HOUSING	Green PP15-45 Anderson Housing
A16			CONN SHUNT 2POS 0.100"
A17			CONN SHUNT 2POS 0.100"
A18			CONN SHUNT 2POS 0.100"
A19			CONN SHUNT 2POS 0.100"
A20			CONN SHUNT 2POS 0.100"
A21			CONN SHUNT 2POS 0.100"
BNC4		BNCPC\500	BNC Jack
C6	10nF	0603	X7R 50V
C7	4.7µF	0805	X7R 16V
C8	100nF	0603	X7R 25V
C9	100nF	0603	X7R 25V
C10	100nF	0603	X7R 25V
C11	100nF	0603	X7R 25V
C30	0.10µF	0603	X7R 25V
C31	0.10µF	0603	X7R 25V
C32	47nF	IGNORE	Capacitor, Polypropylene Film, 300V AC, Y2, 47nF, 20%, 18x8.5mm
C46	OPEN	2220	
C47	1000pF	1206	X7R 2000V
C48	OPEN	2220	
C49	150µF/450V	IGNORE	Aluminum Electrolytic Cap, 150µF, 450V, 20%, Radial 22mm x 52mm
C50	150µF/450V	IGNORE	Aluminum Electrolytic Cap, 150µF, 450V, 20%, Radial 22mm x 52mm
C51	150µF/450V	IGNORE	Aluminum Electrolytic Cap, 150µF, 450V, 20%, Radial 22mm x 52mm
C52	150µF/450V	IGNORE	Aluminum Electrolytic Cap, 150µF, 450V, 20%, Radial 22mm x 52mm
C53	OPEN	2220	
C54	OPEN	2220	
C55	OPEN	18x8.5mm	Capacitor, Polypropylene Film, 300v AC, Y2, 47nF, 20%, 18x8.5mm
C56	470µF/100V	Radial Lead	Radial Leaded Aluminum Capacitor, 470uF/100V, 20%, Radial 16mm x 25mm x 7.5mm
C57	470µF/100V	Radial Lead	Radial Leaded Aluminum Capacitor, 470uF/100V, 20%, Radial 16mm x 25mm x 7.5mm
C58	470µF/100V	Radial Lead	Radial Leaded Aluminum Capacitor, 470uF/100V, 20%, Radial 16mm x 25mm x 7.5mm
C59	470µF/100V	Radial Lead	Radial Leaded Aluminum Capacitor, 470uF/100V, 20%, Radial 16mm x 25mm x 7.5mm
C60	470µF/100V	Radial Lead	Radial Leaded Aluminum Capacitor, 470uF/100V, 20%, Radial 16mm x 25mm x 7.5mm
C61	470µF/100V	Radial Lead	Radial Leaded Aluminum Capacitor, 470uF/100V, 20%, Radial 16mm x 25mm x 7.5mm
C62	470µF/100V	Radial Lead	Radial Leaded Aluminum Capacitor, 470uF/100V, 20%, Radial 16mm x 25mm x 7.5mm
C63	470µF/100V	Radial Lead	Radial Leaded Aluminum Capacitor, 470uF/100V, 20%, Radial 16mm x 25mm x 7.5mm
C64	470µF/100V	Radial Lead	Radial Leaded Aluminum Capacitor, 470uF/100V, 20%, Radial 16mm x 25mm x 7.5mm
C65	470µF/100V	Radial Lead	Radial Leaded Aluminum Capacitor, 470uF/100V, 20%, Radial 16mm x 25mm x 7.5mm
C167	0.047µF	0603	X7R 16V
C169	0.33µF	0603	X7R 16V

Ref Des	Value	Package	Description
C170	0.33 μ F	0603	X7R 16V
C171	0.33 μ F	0603	X7R 16V
C172	0.10 μ F	0603	X7R 16V
D20	5V	SOT-23	TVS Double BIDI ESD Protection Diodes, 5V, SOT-23
F1		IGNORE	Fuse 15A, 250 V ABC 1/4? x 1 1/4? Fast-acting ceramic tube
F2		IGNORE	Fuse 15A, 250 V ABC 1/4? x 1 1/4? Fast-acting ceramic tube
FB2	120 η H	0805	120nH, 25%, 0805 Ferrite Bead
FB3	120 η H	0805	120nH, 25%, 0805 Ferrite Bead
FH1			Fuse Holder, PCB Mount
FH2			Fuse Holder, PCB Mount
J1			HEADER, 2P, VERT
J2			HEADER, 2P, VERT
J3		USB MICRO B	USB Micro-B Female SMT Receptacle
J4			HEADER, 2P, VERT
J5			HEADER, 2P, VERT
J7			HEADER, 2P, VERT
J8		IGNORE	12 AWG Bus Wire, 1? wide, 1? tall, Insulated Jumper
J9			HEADER, 2P, VERT
J10			HEADER, 2P, VERT
J12		IGNORE	12 AWG Bus Wire, 1? wide, 1? tall, Insulated Jumper
J13			HEADER, 2P, VERT
J14			RIGHT-ANGLE FEMALE DB9 CONNECTOR, TH HOLE
J5			HEADER, 2P, VERT
J18			HEADER, 2P, VERT
J22			Right Angle 25A Crimp pin for anderson connectors
J24			Right Angle 25A Crimp pin for anderson connectors
J25	OPEN		Pin hole for Anderson Connector Mounting
J26	OPEN		Pin hole for Anderson Connector Mounting
J27			Right Angle 25A Crimp pin for anderson connectors
J28			Anderson Connector PCB Mount Staple Spanning 3 Modules
J30			Right Angle 25A Crimp pin for anderson connectors
J31			Right Angle 25A Crimp pin for anderson connectors
J32			Anderson Connector PCB Mount Staple Spanning 4 Modules
J33	OPEN		Pin hole for Anderson Connector Mounting
J34			Anderson Connector PCB Mount Staple Spanning 4 Module
J36			Right Angle 25A Crimp pin for anderson connectors
J37			Right Angle 25A Crimp pin for anderson connectors
J40			Right Angle 25A Crimp pin for anderson connectors
J42			Right Angle 25A Crimp pin for anderson connectors
J42			Right Angle 25A Crimp pin for anderson connectors
J43			Right Angle 25A Crimp pin for anderson connectors
J44			Right Angle 25A Crimp pin for anderson connectors
J46			HEADER, 2P, VERT
J47			HEADER, 2P, VERT
J48			HEADER, 2P, VERT
J49			HEADER, 2P, VERT
JA		2MM_5_2_SOCKET	Low Profile Bottom Entry 2mm Socket 10 Pin Dual Row
LED_3V3		LED0603	LED Green Clear SMD
LED_ACG		LED0603	LED Green Clear SMD
LED_B1		LED0603	LED Green Clear SMD
LED_B4		LED0603	LED Green Clear SMD
LED_B5		LED0603	LED Green Clear SMD
LED_BS		LED0603	LED Red Orange Clear SMD
LED_DO		LED0603	LED Red Orange Clear SMD

Ref Des	Value	Package	Description
LED_DCG		LED0603	LED Green Clear SMD
LED_ENA		LED0603	LED Red Orange Clear SMD
LED_RX		LED0603	LED Red Orange Clear SMD
LED_SS		LED0603	LED Green Clear SMD
LED_TX		LED0603	LED Green Clear SMD
LED_VOUT		LED0603	LED Green Clear SMD
LED_WARN		LED0603	LED Red Orange Clear SMD
LED4		LTST-C195	BI-COLOR GREEN/YELLOW LED
LI4		Radial	Neon Lamp
LI5		Radial	Neon Lamp
M1	400V	SMC	400V Bidirectional TVS Diode, SMC
PCB1		5.586" X 11.125"	ISO 1PH PFIC FB CUST EVAL BOARD 4 LAYERS, 3OZCU INNER, 1OZCU OUTER, 1UP, .093THK, ENIG, PTH
Q5	100V	SOT-23	N-Channel Mosfet, 100V
Q8	100V	SOT-23	N-Channel Mosfet, 100V
Q9	60V	SOT-23	N D-FET, 60V, SOT-23, 8 Ohms
Q10	60V	SOT-23	N D-FET, 60V, SOT-23, 8 Ohms
Q11	60V	SOT-23	N D-FET, 60V, SOT-23, 8 Ohms
Q13	100V	SOT-23	N-Channel Mosfet, 100V
Q14	100V	SOT-23	N-Channel Mosfet, 100V
R1	511	0603	Resistor
R2	511	0603	Resistor
R3	511	0603	Resistor
R4	511	0603	Resistor
R5	511	0603	Resistor
R6	4.02K	0805	Resistor, 4.02k, 1%, 0805
R7	4.02K	0805	Resistor, 4.02k, 1%, 0805
R8	4.02K	0805	Resistor, 4.02k, 1%, 0805
R9	7.5K	1210	Resistor
R10	7.5K	1210	Resistor
R11	7.5K	1210	Resistor
R12	511	0603	Resistor
R13	4.02K	0805	Resistor, 4.02k, 1%, 0805
R14	511	0603	Resistor
R15	4.02K	0805	Resistor, 4.02k, 1%, 0805
R16	4.02K	0805	Resistor, 4.02k, 1%, 0805
R17	499	0603	Resistor
R21	499	0603	Resistor
R23	20	0603	Resistor
R28	1.00Meg	0603	Resistor
R29	511	0603	Resistor
R34	511	0603	Resistor
R35	20	0603	Resistor
R38	2.00K	0603	Resistor
R39	100	0603	Resistor
R40	511	0603	Resistor
R41	49.9	0603	Resistor
R42	3.16K	0603	Resistor
R43	10.0k	0603	Resistor
R44	1.00Meg	0603	Resistor
R45	71.5	0603	Resistor
R46	1.00K	0603	Resistor
R47	49.9	0603	Resistor

Ref Des	Value	Package	Description
R48	1.00Meg	0603	Resistor
R49	1.00Meg	0603	Resistor
R52	499	0603	Resistor
R53	499	0603	Resistor
R61	49.9K	0805	Pulse Proof Resistor
R62	49.9K	0805	Pulse Proof Resistor
R63	49.9K	0805	Pulse Proof Resistor
R64	49.9K	0805	Pulse Proof Resistor
R65	49.9K	0805	Pulse Proof Resistor
R66	49.9	0603	Resistor
R67	0	0603	Resistor
R68	1.00K	0603	Resistor
R69	7.5K	1210	Resistor
R70	1.00K	0603	Resistor
R71	7.5K	1210	Resistor
R72	1.00K	0603	Resistor
R73	7.5K	1210	Resistor
S1			SPDT-T series Subminiature toggle switch
S2			SPDT-T series Subminiature toggle switch
TH_3V3			PC Test Point Compact Black
TH_ACG			PC Test Point Compact Black
TH_BS			PC Test Point Compact Black
TH_D3			PC Test Point Compact Black
TH_DCG			PC Test Point Compact Black
TH_ENA			PC Test Point Compact Black
TH_RX			PC Test Point Compact Black
TH_START_SYNC			PC Test Point Compact Black
TH_SYNCO			PC Test Point Compact Black
TH_TX			PC Test Point Compact Black
TH_WARN			PC Test Point Compact Black
TH3			PC Test Point Compact Black
TH17			PC Test Point Compact Black
TS1			PC Test Point Compact Red
TS2			PC Test Point Compact Red
TS3			PC Test Point Compact Red
TS4			PC Test Point Compact Red
TS5			PC Test Point Compact Red
U1		SSOP-16	USB-UART Bridge by FTDI
U2		SO-8	DUAL COMPARATOR
U10		SO-8	Dual-Channel Digital Isolator, SO-8, Bi-Directional, 150Mbps, Safety Rated
U49		SO-16	RS-232
Z1	300 V AC	12mm Disc	Metal Oxide Varistor