

EVAL-1000041

Evaluation Board for MCOTS-C-270-xx-HE or MCOTS-C-270-xx-FE Converters

Summary

SynQor has developed the EVAL-1000041, an evaluation board to facilitate testing of our MCOTS-C-270-XX-HE and MCOTS-F-270-P-QT or MCOTS-C-270-xx-FE converter and MCOTS-F-270-P-HT EMI filter.

Introduction

This application note is a guide to the features, schematic, component placement, and BOM for this evaluation board. The applicable converter modules are MCOTS-C-270-xx-HE and MCOTS-F-270-P-QT or MCOTS-C-270-xx-FE converter and MCOTS-F-270-P-HT EMI filter.

Contents

Section 1 – Converter Description	2
Section 2 – Evaluation Board Configuration	2
Section 3 – Evaluation Board Block Diagram	2
Section 4 – Input and Output Connections	3
Section 5 – Switches, Test Points and BNC Connectors	3
Section 6 – Schematic	4
Section 7 – Component Placement	5
Section 7 – Basic Operation Instructions	5
Section 8 – Basic Operating Instructions	6
Appendix A – Bill of Materials (BOM)	7
Required Components	8

This evaluation board and schematic are intended for demonstration purposes only and no guarantees are made for standards compliance.

Shock Warning: There are areas of this evaluation board that have exposed access to hazardous high voltage levels. Exercise caution to avoid contact with those voltages. Also note that the evaluation board may retain high voltage temporarily after input power has been removed. Exercise caution when handling.

Application of Input Power: Never apply input power to a convertor with a switch closure, such as a knife switch or circuit breaker. That type of action applies input voltage with an uncontrolled very high rate of rise (dV/dt) that could be damaging to the convertor and to external components before the convertor. Instead, apply input voltage with a controlled rate of rise. Also ensure input voltage is off before inserting or removing a convertor module from the evaluation board.

Thermal Considerations: When testing EMI filters and converters on an evaluation board, ensure adequate cooling. Apply cooling air with a fan blowing across the EMI filter and the converter or across the heatsinks attached to the EMI filter and converter. Monitor the EMI filter and converter temperatures to ensure they don't exceed the maximum rated per the datasheets specifications.

Isolation Warning: Circuitry on this evaluation board is both isolated and non-isolated with respect to the inputs on J1. This requires great care in making connections and taking measurements. As such, take great care before taking any measurement with equipment that may make a connection to ground. Use isolated differential probes or clamp on style current probes to avoid these issues. The circuits that are isolated from the DC line input can use a regular grounded scope probe to take measurements.

Section 1 – Converter Description

The MCOTS-C-270-xx-HE and MCOTS-C-270-xx-FE Modules are high power, high efficiency DC-DC converters. They operate from a DC (155 V - 425 V) input and generate an isolated DC output. The output voltages of both modules have droop characteristics. The output voltage and max deliverable current can be set with a simple resistor or voltage source. Both units have Sync In, Sync Out, Battle Short, Ishare, and Serial communications capabilities.

Both units have two stages. The input DC stage (155 Vdc - 425 Vdc) steps the input down to a midbus voltage. This input stage also provides isolation between the input and the output of the unit. The midbus voltage is adjusted in the second stage to the desired regulated output by means of the unit either a bucking or boosting.

Section 2 – Evaluation Board Configuration

This evaluation board can be used for either MCOTS-C-270-xx-HE or MCOTS-C-270-xx-FE families. Careful consideration of the input filter current rating need to be taken into account selecting filter and converter modules. The MCOTS-F-270-P-QT filter should only be used with the MCOTS-C-270-xx-HE. The MCOTS-F-270-P-HT has appropriate current rating capability for either the –HE or –FE products.

Another major difference is that the MCOTS-C-270-xx-FE family has an isolated On/Off circuitry. This means that the MCOTS-C-270-xx-FE requires an external power source to disable the output via SW1. In the case of the MCOTS-C-270-xx-FE, make sure the JMP1 is not populated and +5 V must be connected between +5 V test point and On/Off- test point for the enable switch (SW1) to turn the unit off.

For the MCOTS-C-270-xx-HE, JMP1 must be populated with SynQor part number 707-0000030. No voltage is needed between +5 V and On/Off-. The enable switch (SW1) will turn the unit on and off.

Section 3 – Evaluation Board Block Diagram

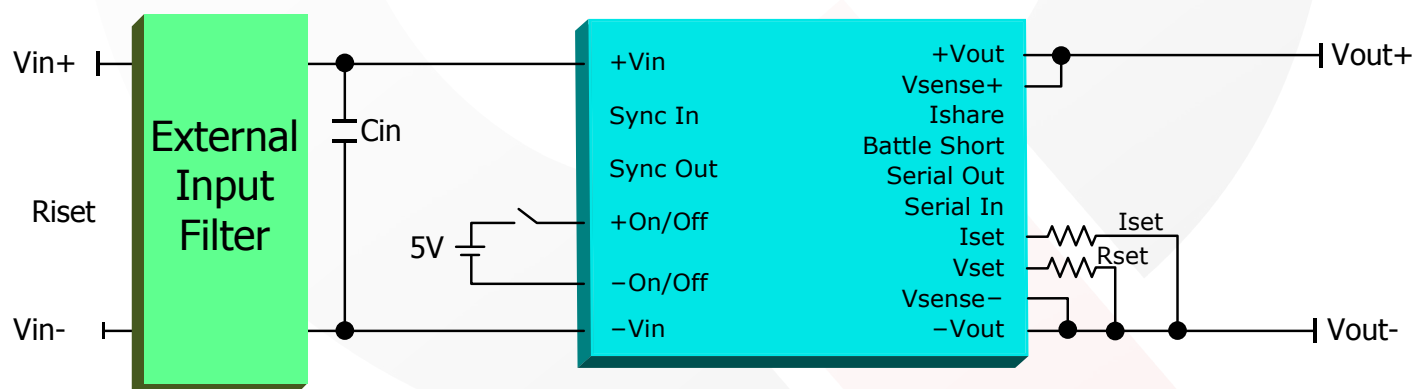

Note 1: An Input Stability calculation will need to be performed to ensure proper damping of the system. Use the SynQor application notes “Guidelines for Testing SynQor DC-DC Converters” and “Input System Instability” to cover the topics of properly testing and implementing the DC-DC converters as a load when using this evaluation board.

Section 4 – Input and Output Connections

Input power is applied through connector J1, see Table 1.

Output power is delivered through connector J2. See Table 2. .

Table 1: Input Power Connector J1

Connector Terminal #	Signal Name
J1-1	Vin+
J1-2	Vin+
J1-3	Vin-
J1-4	Vin-

Table 2: Output Power Connector

Connector Terminal #	Signal Name
J2 - (15-22)	VOUT+
J2 - (1-8)	VOUT-

Section 5 – Switches, Test Points and BNC Connectors

Description of Switches

Enable On/Off Switch

Toggling SW1 switch to the ON position enables the MCOTS-C-270-xx-FE unit if +5 V is applied between +5 V and On/Off-. Toggling SW1 switch to the OFF position disables the -FE converter. If an external voltage is not applied between +5 V and On/Off- test points, the unit will run regardless of SW1 position.

Toggling SW1 switch to the ON position enables the MCOTS-C-270-xx-HE. No voltage is applied between the +5 V and On/Off- pin for the -HE product. Toggling SW1 switch to the OFF position disables the -HE converter.

Description of Various Test Points (Vset, Iset, VSNS-, BS, SER_IN, and SER_OUT)

Vset test point with respect to Vsns- test point is the same connection as VSET BNC. This allows a customer to apply a voltage or a fixed resistance between the two connections to set the nominal output voltage.

Iset test point with respect to Vsns- test point is the same connection as ISET BNC. This allows a customer to apply a voltage or a fixed resistance between the two connections to set the maximum output current the module can deliver.

BS (Battle Short) test point with respect the Vsns- test point goes high when the unit is within 5 °C of the over-temperature shut down. Pulling the BS pin low with respect to Vsns- will disable the over-temperature shutdown.

SER_IN (SERIAL_IN) test point with respect to Vsns- test point allows for Serial communication with the unit. See the separate “MCOTS-C-270-xx-FE Serial Interface” companion document for detailed command syntax (available at: <https://www.synqor.com/document-viewer?document=MCOTS-C-270-xx-FE%20Serial%20Interface.pdf%20>).

SER_OUT (SERIAL_OUT) test point with respect to Vsns- test point allows for Serial communication with the unit. See the separate “MCOTS-C-270-xx-FE Serial Interface” companion document for detailed command syntax (available at: <https://www.synqor.com/document-viewer?document=MCOTS-C-270-xx-FE%20Serial%20Interface.pdf%20>).

BNC Monitoring Point Descriptions

- Vin – Converter Input Voltage
- Vout+ - Converter Output Voltage
- Ishare – Ishare bus voltage
- Sync In – Input to sync the convertor Fsw
- Sync Out – Output squarewave at Fsw
- Vset – Voltage applied to set the Vout+
- Iset – Voltage applied to set Imax

Section 6 – Schematic

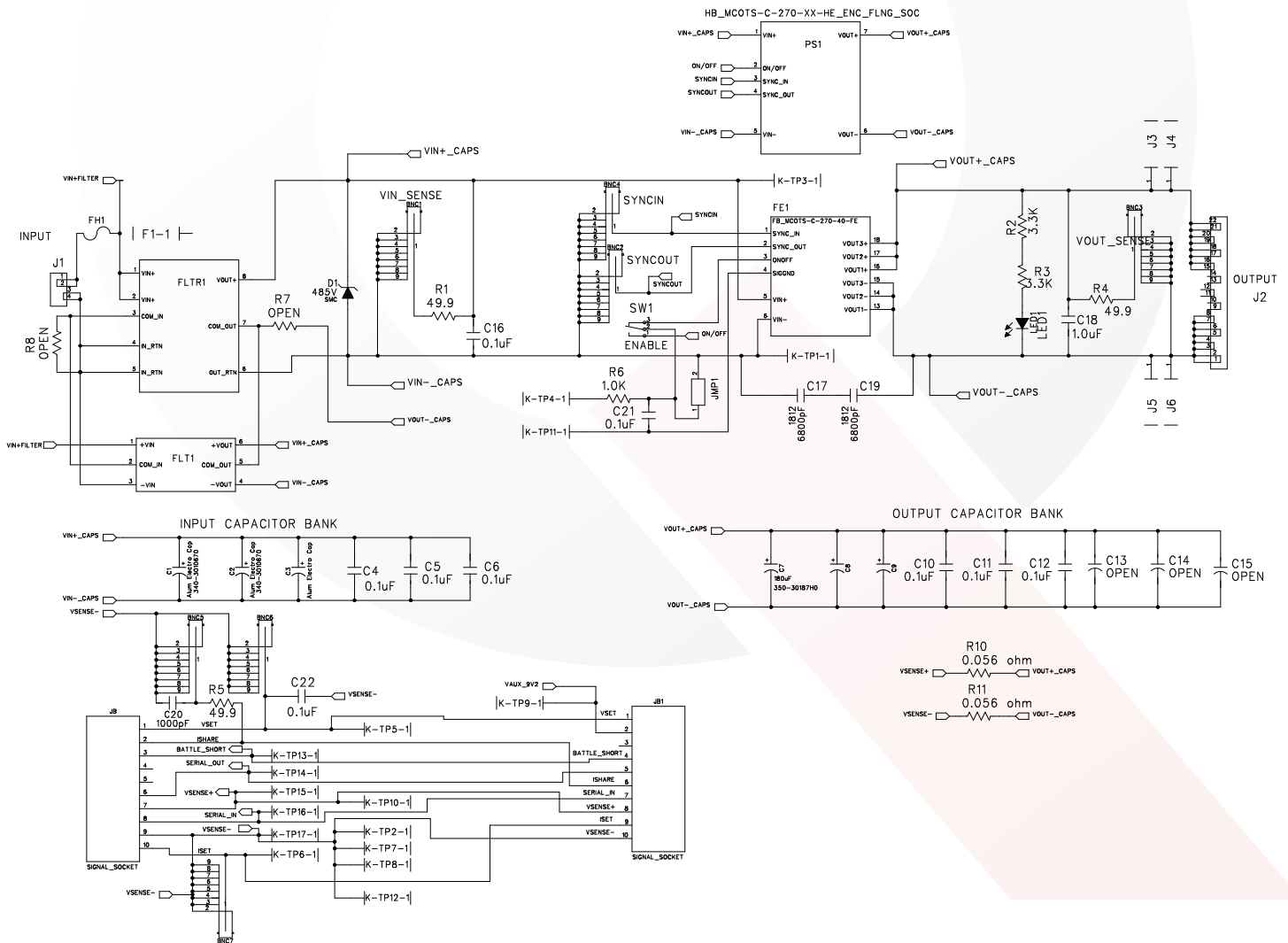

Section 8 – Basic Operating Instructions

Choose the Vset resistance or voltage based on desired output voltage and connect between the Vset and vsns-test points apply.

Choose the Iset resistance or voltage based on the desired maximum output current.

If testing the MCOTS-C-270-xx-FE, Apply +5 V between +5 V test point and On/Off- test point. If testing the MCOTS-C-270-xx-HE, then +5 V is not needed.

Connect the loads at +Vout to J2 (15-22) and –Vout to J2 (1-8) for the regulated DC output.

Apply the 155 Vdc - 425 Vdc at J1 on left.

Use Switch S1 in lower right for enable / disable control.

Capacitor Banks on the Evaluation Board

The test board has a mixture of aluminum electrolytic (30 μ F 450 V rated) and ceramic capacitance (0.3 μ F 630 V rated) at the input of the converter. An Input Stability calculation will need to be performed to ensure proper damping of the system. Use the SynQor application notes “Guidelines for Testing SynQor DC-DC Converters” and “Input System Instability” to cover the topics of properly testing and implementing the DC-DC converters as a load when using this evaluation board

The test board includes a small amount of output capacitance on the MAIN OUTPUT. A feature of the MCOTS-C-270-xx-HE and –FE products are there ability to run into essentially infinite amount of output capacitance. The device only requires a minimum amount of capacitance (100 μ F) at the output for normal operation.

Output Capacitors are a mix of aluminum electrolytic and ceramic for good ESR at low temperature and lifetime at high temperature. The voltage rating for the aluminum electrolytic cap is 160 V. The ceramic caps have a 630 V rating.

Serial Interface Communications

Please refer to application note “MCOTS-C-270-xx-FE Serial Interface” document for detailed command syntax (available at www.synqor.com/pdf/MCOTS-C-270-xx-FE_Serial_Interface.pdf).

Appendix A – Bill of Materials (BOM)

Ref Des	Value	Package	Description
FH1		6.3 x 32 mm	Fuse holder for 10.0 x 38 mm Fuse
F1	10 A	10.0 x 38 mm	Fuse, 10 A, Fast Blow, 500 V, 10.0x38 mm
J1	600 V	Molex 2 terminal block	Molex 2 terminal block 600 V THT
J2	60 A, 600 V	Molex 11 terminal block	Connector, 11 pin, 600 V, 60 A per pin, 8-18 AWG
D1	485 V	SMC	485 V Bidirectional TVS Diode
BNC1		THT	BNC Jack
BNC2		THT	BNC Jack
BNC3		THT	BNC Jack
BNC4		THT	BNC Jack
BNC5		THT	BNC Jack
BNC6		THT	BNC Jack
BNC7		THT	BNC Jack
SW1			On-None-On Toggle Switch
R1	49.9	0805	Resistor
R2	3.3K	1210	Resistor
R3	3.3K	1210	Resistor
R4	49.9	0805	Resistor
R5	49.9	0805	Resistor
R6	1.0K	0805	Resistor
R7	OPEN	2010	Resistor
R8	OPEN	2010	Resistor
JMP1		THT	2 pin header
R10	0.0	0805	Resistor
R11	0.0	00805	Resistor
C1	10 μ F	Radial	Aluminum Electrolytic Thru Hole, 450 V
C10	0.1 μ F	1812	Ceramic SMT, 630 V
C11	0.1 μ F	1812	Ceramic SMT, 630 V
C12	0.1 μ F	1812	Ceramic SMT, 630 V
C13	OPEN	D-Case	Tantalum SMT
C14	OPEN	D-Case	Tantalum SMT
C15	OPEN	D-Case	Tantalum SMT
C16	0.1 μ F	1812	Ceramic SMT, 630 V
C17	6800pF	1812	Johanson Ceramic SMT, 2000 V
C18	1.0 μ F	0805	Ceramic SMT, 50 V
C19	6800pF	1812	Johanson Ceramic SMT, 2000 V
C2	10 μ F	Radial	Aluminum Electrolytic Thru Hole, 450 V
C20	0.1 μ F	1812	Ceramic SMT, 630 V
C21	0.1 μ F	1812	Ceramic SMT, 630 V
C22	0.1 μ F	1812	Ceramic SMT, 630 V
C3	OPEN	Radial	Aluminum Electrolytic, Thru Hole, 450 V
C4	0.1 μ F	1812	Ceramic SMT, 630 V
C5	0.1 μ F	1812	Ceramic SMT, 630 V
C6	0.1 μ F	1812	Ceramic SMT, 630 V
C7	OPEN	Radial	Solid Polymer Electrolytic SMT, 80 V
C8	OPEN	Radial	Solid Polymer Electrolytic SMT, 80 V
C9	180 μ F	Radial	Aluminum Electrolytic Thru Hole, 160 V

Required Components

– to be installed for MCOTS-C-270-xx-HE and MCOTS-C-270-xx-FE

Ref Des	MCOTS-C-270-xx-HE	MCOTS-C-270-xx-FE
FLT1	MCOTS-F-270-P-QT	OPEN
FLTR1	OPEN	MCOTS-F-270-P-HT
PS1	MCOTS-C-270-(40,60)-HE	OPEN
FE1	OPEN	MCOTS-C-270-(40,60)-FE
JMP1	SynQor 707-0000030 Jumper	REMOVE