

UPS **MILITARY SHELTER-GRADE**

UNINTERRUPTIBLE POWER SUPPLY

Operator's Guide *UPS-MS-1500 Series*



UPS-MS-1500-S-2U



SynQor
Advancing The Power Curve®

Table of Contents

SECTION I

WARNINGS

Hazardous Voltages	1
Hazardous Energies	2
Battery Pack.....	2
Protection from the Environment	3
No User Serviceable Parts	3

SECTION II

GENERAL PRODUCT INFORMATION

Product Description	4
Product Topology	5
Part Numbering Scheme and Options.....	6
Product Specifications.....	6
Electrical Characteristics.....	8
2U Mechanical Diagram.....	9
UPS Efficiency	10
Total Output Power that can be derived from the AC INPUT	10
Power Cable Wiring Diagram.....	13
Power Cable Wire Size	14

SECTION III

OPERATION

Set-Up	15
Start-Up.....	15
Shut-Down	16
Power Cable Connections/Disconnections While Operating.....	17
Cooling System	18
Front Panel Indicators	19
LEDs	19
Audible alarm.....	24
Hot Swapping the Battery Pack	24
Operating Environment.....	25

SECTION IV

BATTERY PACK

Battery Technology	26
Electronic Circuitry within the Battery Pack.....	26
Battery Capacity.....	27
Battery Pack Replacement	27
Handling the Battery Pack.....	28

SECTION V

CONTROL INTERFACE DETAILS

Control Cable Connections	29
Internal User I/O Circuits	30
Remote On/Off Switch Connections.....	30
Digital Input/Output Control Signals.....	31
RS232 Serial Interface	31
Ethernet Interface	32

SECTION VI

MAINTENANCE

Battery	33
Fans.....	33
Cleaning	33

SECTION VII

TROUBLE-SHOOTING GUIDE

Fault Conditions.....	34
-----------------------	----

Hazardous Voltages

The **INPUT AND OUTPUT POWER** connectors and cables of the SynQor UPS may have voltages that are unsafe. **INJURY OR DEATH ON CONTACT** may result. Appropriate safety precautions should be taken. All connections should be made in accordance with **LOCAL ELECTRICAL CODES**.

- The UPS **CHASSIS** should be connected to earth or system ground with Ground Stud on the rear panel, see mechanical diagrams.
- For the **AC INPUT** cable and connector:
 - Do not assume that a hazardous voltage is not present at the terminals of the AC input connector, even if the UPS appears to be off.
 - Do not make contact with the terminals of the AC input connector.
 - Always connect the cable to the UPS before it is connected to the source of AC power.
 - Always disconnect the AC input cable from the source of AC power before disconnecting it from the UPS.
 - If the AC input cable is connected to the source of AC power and not connected to the UPS, do not contact the exposed terminals of the AC input cable.
 - Do not assume that the source of AC power is not present.
 - Connections between the AC input cable and the source of AC power should not be accessible.
- For the **AC OUTPUT** cable and connector:
 - Do not assume that a hazardous voltage is not present at the terminals of the AC output connector, even if the UPS appears to be off.
 - Do not make contact with the terminals of the AC output connector.
 - Connect the AC output cable to the UPS before the UPS is turned on.
 - If connection of the load to the AC output cable has exposed conductors, make this connection before connecting the AC output cable to the UPS.
 - Connections between the AC output cable and the load should not be accessible.
- For the **BATTERY PACK** (if not inserted into the UPS):
 - When the battery pack is not inserted into the UPS, the battery is internally disconnected from the power pins of the battery pack's connector.
 - Even if this disconnection were not present, the DC voltage of the battery is below the level considered hazardous.
 - Do not apply external voltages to the pins of an exposed battery pack connector. It is not possible to charge the battery pack from an external source, and excess voltages could damage internal control circuitry.

Hazardous Energies

The **INPUT AND OUTPUT POWER** connectors and cables of the SynQor UPS may be the source of high levels of energy. Do not inappropriately make electrical contact between any terminal of a connector and another, or between any wire of a cable and another, or between any terminal or wire and the UPS's chassis or ground. **DAMAGING ELECTRICAL ARCS** may result. Care should be taken to avoid accidental electrical contacts of this sort.

When the **BATTERY PACK** is not inserted into the UPS, the battery is internally disconnected from the power pins of the battery pack's connector. An electrical contact between any two of these power pins or between any power pin and ground should therefore not be damaging. However, care should take to avoid accidental electrical contacts of this sort.

Battery Pack

The individual **LITHIUM ION BATTERIES** contained in the SynQor battery pack are sealed units that are further mechanically protected by the battery pack's chassis and electrically protected by the battery pack's electronic circuitry. Under normal conditions they do not pose a hazard, but they should not be physically, thermally or electrically abused.

The **TRANSPORT** of the battery pack must comply with applicable regulations of the locality. See "Battery Pack - Handling the Battery Pack".

The battery pack should be **DISPOSED** in accordance with applicable regulations of the locality or **RETURNED** to a factory-authorized Service Center.

Emergency response contact information for battery damage, leaks, smoke, or fires can be found at the following link: <https://www.SynQor.com/UPS/documents/Contact.pdf>. Please contact the SynQor factory for all other questions regarding the UPS battery pack.

CAUTION: Do not dispose of batteries in a fire. The batteries may explode.

CAUTION: Do not open or mutilate batteries. Released electrolyte is harmful to the skin and eyes. It may be toxic.

Always use the proper SynQor battery pack. See the battery replacement chart on page 27.

Protection from the Environment

The SynQor UPS is an environmentally tough product having its electronics and battery contained in an ultra-sturdy chamber. It is capable of withstanding harsh levels of mechanical acceleration, shock and vibration, temperature and pressure variations within the levels specified in the data sheet. **THESE LEVELS SHOULD NOT BE EXCEEDED.**

Do not obstruct the air intake in the front of the UPS or the fan exhausts in the rear panel of the UPS while the UPS is operating.

No User Serviceable Parts

The SynQor UPS has no user serviceable parts inside of it. **DO NOT REMOVE** the cover of the UPS or any of its connectors. **DO NOT OPEN** the battery pack. **DO NOT TRY TO ACCESS** or touch any components inside the UPS-MS-1500 through the battery compartment opening. Only factory trained personnel should perform repairs.

Product Description

The SynQor UPS-MS-1500 Series is an advanced technology Military Shelter-Grade Uninterruptible Power Supply (UPS-MS) that uses lithium ion batteries and highly efficient power electronic circuitry to achieve a high power level and battery run-time in a 2U, low-weight, rack-mountable package. It provides voltage and frequency conditioning, electrical isolation, and power flow smoothing between the power input and its power outputs. It provides battery backed-up power when the AC input power is not present.

A communication/control port is available to permit monitoring and control by a host computer system. Front panel LEDs and an audible alarm provide information on the status of the UPS and the battery pack.

The UPS-MS-1500 Series products can draw power from an AC input having a wide range of voltage levels and frequencies. The UPS provides up to 1500 VA and 1250 W of AC output power at 115 Vac or 230 Vac. The pure sine wave AC output voltage can drive any non-linear load with a crest factor up to 2.5, and any load power factor from 0.0 to 1.0.

The electronic circuitry within the UPS-MS-1500 Series products is designed, qualified and screened according to many military standards. It complies with the requirements of MIL-STD-1399-300B and MIL-STD-461F, as well as specifications for world-wide military, aerospace and commercial applications.

The UPS-MS-1500 Series products are designed and manufactured to withstand harsh environments encountered in military applications. The electronic circuitry and battery are contained in a ultra-sturdy chamber constructed of galvanized steel that is environmentally resilient and shock-proof. Redundant fans on the rear panel draw cooling air over the heat sink fins of the steel chassis keeping the air flow away from all of the electronics. The UPS-MS-1500 is equipped with standard computing industry sockets and plugs for ease of use and ultra-fast setups.

The SynQor UPS-MS-1500 Series products are designed and manufactured in the U.S.A.

Product Topology

The SynQor UPS-MS-1500 Series products use a true on-line double conversion topology that provides protection to the load from spikes, noise, surges, brownouts, blackouts, etc. in the input power source. It also provides smoothing of load transients and nonlinear load profiles so that the input power sources are not subjected to these disturbances. There is a seamless transfer from the AC power source to the battery backup and from the battery back to the AC power source with no disruption in the output voltage waveform.

As the figure below shows, there is a nominal 28 V mid-bus within the UPS that draws power from one of two power sources: the AC INPUT, or the battery. EMI filters are present at all external inputs and outputs.

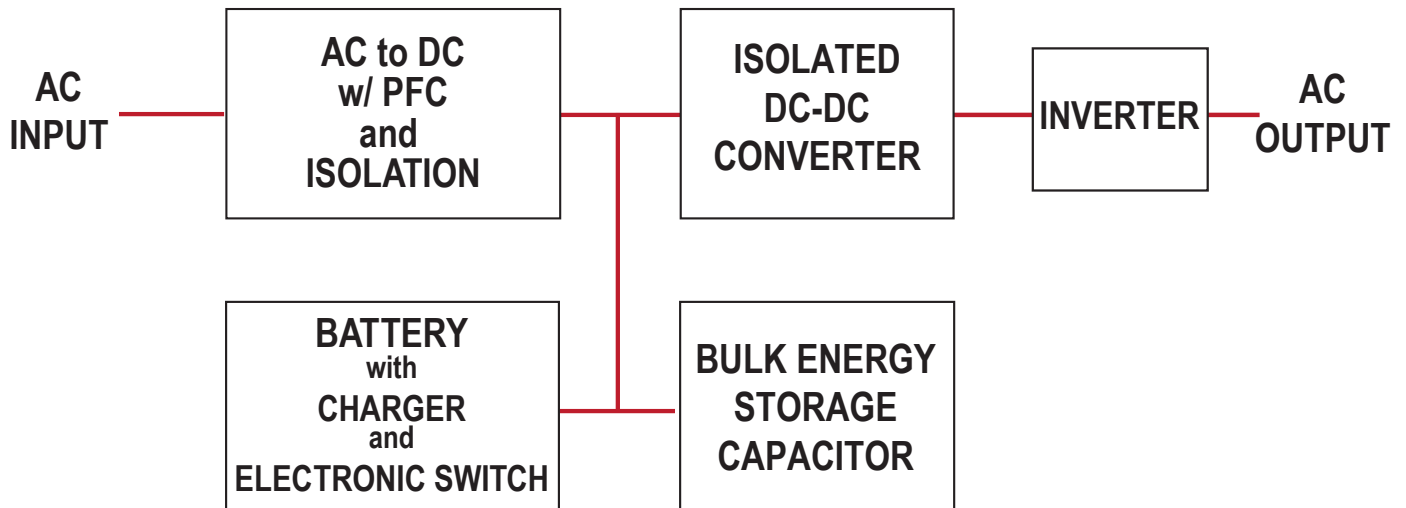

Power flows from the AC INPUT through an AC-DC converter that has Power Factor Correction (PFC) and high-frequency safety isolation. An electronic switch connects the battery to the mid-bus when the AC input source is not present.

The AC OUTPUT is created by an inverter that draws power from the mid-bus. This inverter provides high frequency safety isolation and a pure-sinusoidal output voltage waveform.

Bulk energy storage capacitors are connected to the mid-bus to help smooth imbalances in power flow between the inputs and outputs of the UPS.

There is a battery charger circuit that draws power from the mid-bus. It ensures the batteries are normally fully charged and that the various cells are equalized. The battery also contains protection circuitry to avoid damage due to improper charging or discharging, or to excessive temperatures.

There is a communication/control port that provides a digital interface to a host computer system.

Part Numbering Scheme and Options

This table shows the part numbering scheme for SynQor’s UPS-MS-1500 product options:

AC Base Models				
Model Number	Power	Battery Run-Time @Full Power (80% Power)	Height (W x D x H)	Weight
UPS-MS-1500-S-2U (1 BAT-0200-S Battery Pack)	1250 W 1500 VA	>10 min. (>13 min.)	2U (16.92"W x 22.13"D x 3.40"H)	42 lbs.
UPS-MS-1500-H-2U (1 BAT-0400-H Battery Pack)	1250 W 1500 VA	>13.5 min. (>18 min.)	2U (16.92"W x 22.13"D x 3.40"H)	43.8 lbs.

AC Base Models	Options					Options	
	AC Input Freq	AC Output Voltage	AC Output Neutral Wire	AC Output Set Point Freq	Additional Options	AC Input Freq	Options
UPS-MS-1500-[S,H]-2U-	L	1 2 3 4	G	5 6	-E 00 CE	L 47-65 Hz	1 115 Vrms 2 230 Vrms - EU 3 230 Vrms - UK 4 230 Vrms - ANZ
						G Grounded	
						5 50 Hz 6 60 Hz	
						-E Ethernet/SNMP with Configuration Loading 00 No CE Marking CE CE Marking (230 V only)	

Not all combinations make valid part numbers, please contact SynQor for availability. See the Product Summary web page for more options.

Examples:

UPS-MS-1500-S-2U-L1G6-E00, UPS-MS-1500-S-2U-L2G5-E00
UPS-MS-1500-S-2U-L2G5-ECE (230 V output with CE marking)

The UPS-MS-1500 Series of products provide up to 1500 VA and 1250 W of total output power. The UPS-MS-1500 comes in the following format:

- A 2U high, 42 lb. rackmount unit that uses the standard SynQor 1U battery pack which provides >10 minutes or >13.5 minutes of battery run-time at full power

Each UPS-MS-1500 option can be specified according to the part numbering scheme shown in the table above:

- The allowable frequency of the AC INPUT must be in the 47-65 Hz range (for 50 Hz and/or 60 Hz systems).
- The output voltage of the UPS-MS-1500 Series can be 115 VRMS or 230 VRMS
- The AC output is internally grounded to the chassis of the UPS.
- The initial set-point frequency of the AC OUTPUT voltage can be 50 Hz or 60 Hz. Regardless of the initial set-point frequency, the actual frequency can be set through the communications/control port.
- RS232 serial port and logic-level I/O communication are included in the standard model. An Ethernet port providing web and SNMP interfaces is also in the standard model.

Product Specifications

The following three pages show the electrical and mechanical specifications of the UPS-MS-1500 2U Series of products. Data sheets showing these specifications and other information can be found at the following web site <https://www.synqor.com/UPS>.

SECTION II

GENERAL PRODUCT INFORMATION

UPS-MS-1500

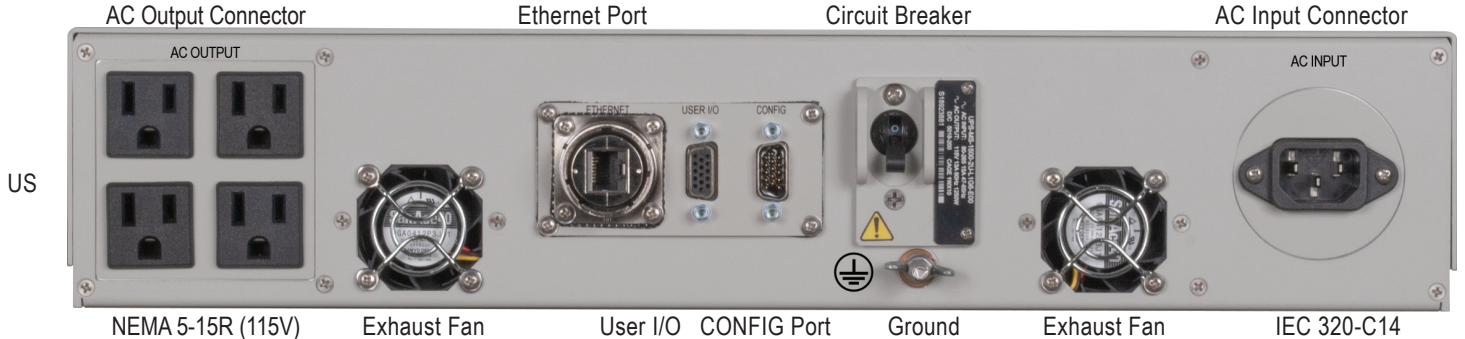
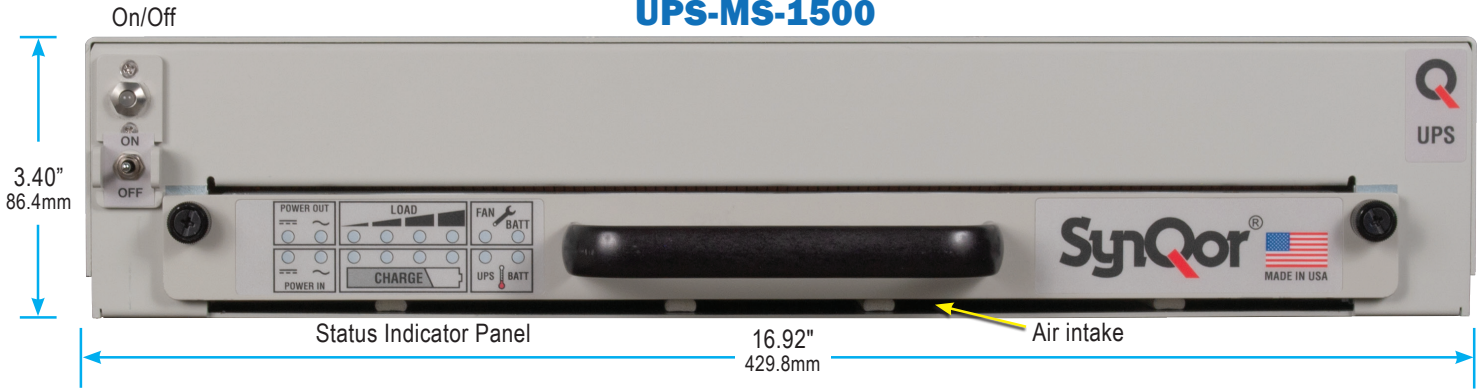

Electrical Characteristics

INPUT CHARACTERISTICS

Operating AC Input

Voltage	80-265 Vrms*
Frequency	47-65 Hz
Input Power Factor	>0.98 at 47-65 Hz
Maximum Input Current Continuous	15 A
AC Input Circuit Breaker Rating (* Power Derating below 110 Vrms)	25 A

OUTPUT CHARACTERISTICS

Total Output Power Continuous	1250 W (1500 VA)
AC Output	
AC Output Waveform	Pure Sinusoidal
Voltage	115 Vrms \pm 3% 230 Vrms \pm 3%
Frequency	60 Hz \pm 0.5% 50 Hz \pm 0.5%
Instantaneous Peak Load Current	26 A (115 Vrms) 13 A (230 Vrms)
Load Power Factor	0-1.0 (leading or lagging)
Total Harmonic Distortion	2% (1000W resistive load)

Specifications subject to change without notice.

ENVIRONMENTAL CHARACTERISTICS MIL-STD-810G

Temperature Methods 501.5, 502.5

Operating Temperature	-10 °C to +50 °C
Non-operating Temperature	-10 °C to +65 °C

Altitude Method 500.5

Operating	0 - 15,000 ft
Non-operating	0 - 40,000 ft

Environmental Tests

Shock/Drop	Method 516.6, Procedure 1
Temperature Shock	Method 503.5, Procedure 1
Vibration	Method 514.6, CAT 24
Humidity	Method 507.5 Procedure 2

RELIABILITY CHARACTERISTICS MIL-HDBK-217F

MTBF	100 kHrs	MIL-217F Ground Benign, Ta=25 °C
------	----------	----------------------------------

ELECTROMAGNETIC CAPABILITY MIL-STD-461F

CE101	30 Hz - 10 kHz
CE102	10 kHz - 10 MHz
CS101	30 Hz - 150 kHz
CS106	10 kHz - 40 GHz
CS114	10 kHz - 200 MHz
CS116	10 kHz - 100 MHz
RE101	30 Hz - 100 kHz
RE102	10 kHz - 18 GHz
RS101	30 Hz - 100 kHz
RS103	2 MHz - 40 GHz
EN55032	Class A

MECHANICAL CHARACTERISTICS

Chassis

Chassis Size	16.92"W x 22.13"D x 3.40"(2U)H
Case Material	Aluminum + Galvanized Steel
Total Weight	42 lbs. (with chassis & battery)

Connectors

AC Input Connector	IEC 320-C14
User I/O Ports	HD DB15 Female
Configuration I/O Port	HD DB15 Male
Ethernet Port	Amphenol RJF22N00, Code B
AC Output Connector(s)	Options
	1 - 4 X NEMA 5-15R (115V)
	2 - 1 X Type F (EU-230V)
	3 - 1 X Type G (UK-230V)
	4 - 1 X Type I (ANZ-230V)

Cooling Exhaust Fans

Sound Pressure Level (SPL)	<55 dB(A)
Air Flow	0.67(m ³ /min) 23.7 CFM

Two fans in system, above specs are for each fan separately.

UPS Efficiency

Figure 1 shows the typical efficiency with which the UPS-MS-1500 series uninterruptible power supplies delivers power to its AC OUTPUT from a 230 Vrms AC INPUT or an 115 Vrms AC INPUT.

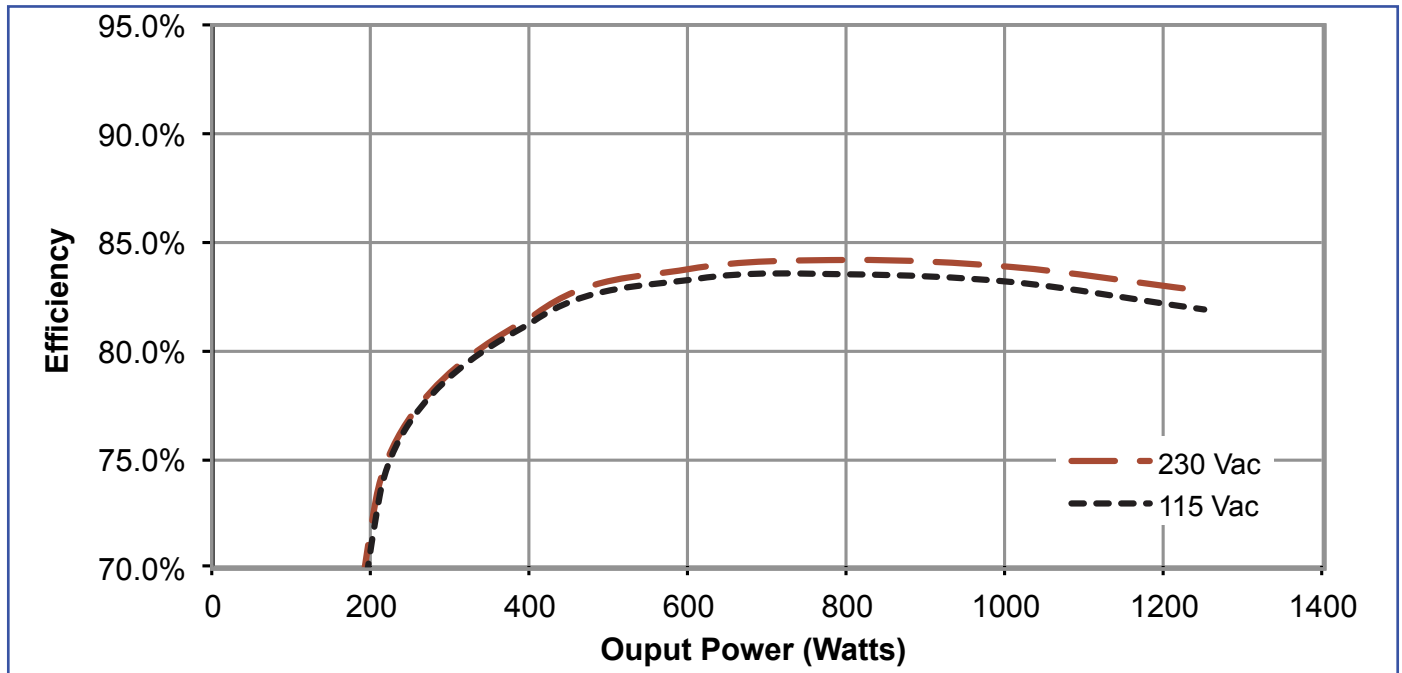

Figure 1

Total Output Power that can be derived from the AC INPUT

The UPS-MS-1500 is rated at 1250 W total power for ambient temperature as high as 50°C (122°F). It draws this power first from the AC INPUT (if its voltage is within range) and then from the internal BATTERY PACK (if it has sufficient charge).

However, when the AC INPUT voltage is at the low end of its range (<110 Vrms) the UPS will not be able to deliver its full rated output power in the steady-state without switching to its internal battery. Figure 2 indicates the total steady-state output power that the UPS can derive **from the AC INPUT** under these extreme conditions. See Figure 3 for information on transient conditions.

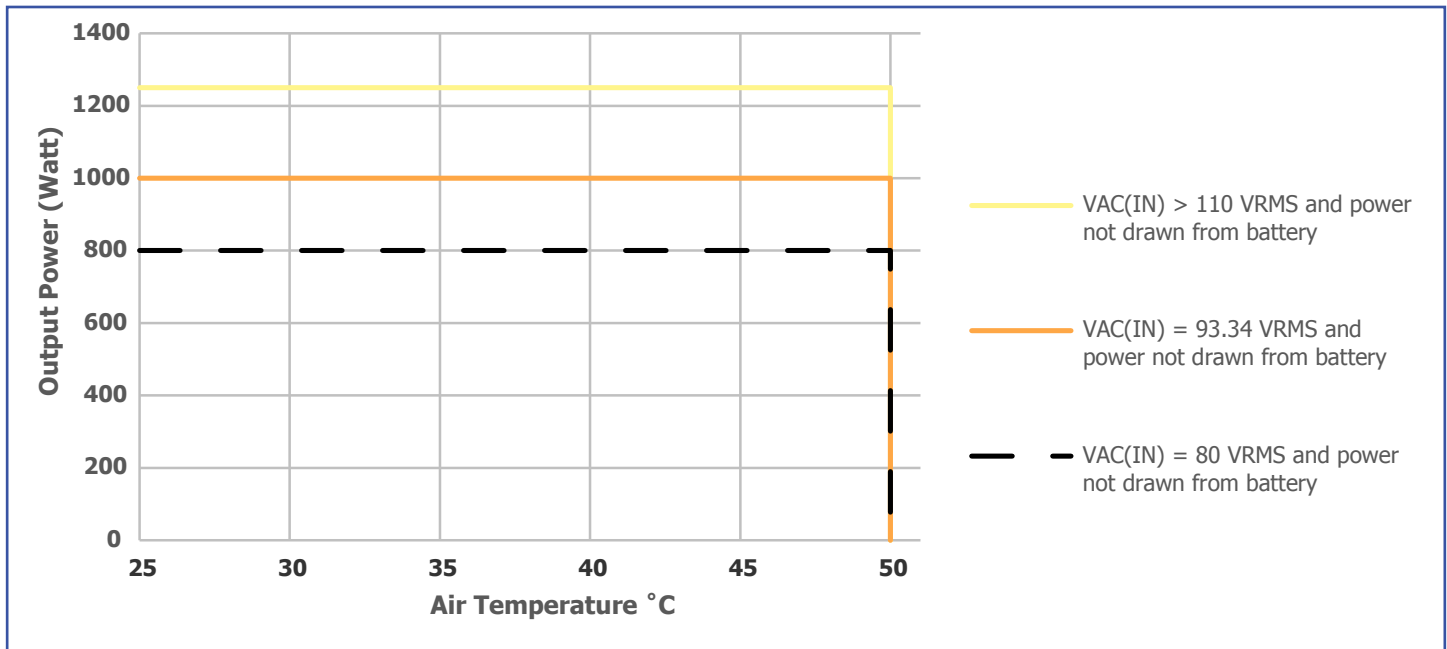

Figure 2

- If the AC INPUT voltage is above 110 Vrms, then the UPS can deliver its full rated output power of 1250 W from the AC INPUT for an ambient temperature as high as 50°C (122°F) without needing to switch over to the internal BATTERY PACK.
- If the AC INPUT is between 110 Vrms and 80 Vrms then the total output power that can be derived from the AC INPUT linearly decreases from 1250 W at 110 Vrms to 800 W at 80 Vrms. For example, the total output power that could be derived from the AC INPUT would be 1100 W at 100 Vrms as long as the ambient temperature is not above 50°C (122°F). If the total output power is greater than this derated value, the UPS will switch to the internal BATTERY PACK.

There is a limited (and uncommon) range of AC INPUT voltage between 132 Vrms and 160 Vrms in which the total output power that can be derived from the AC INPUT is also derated, as shown in the graph below.

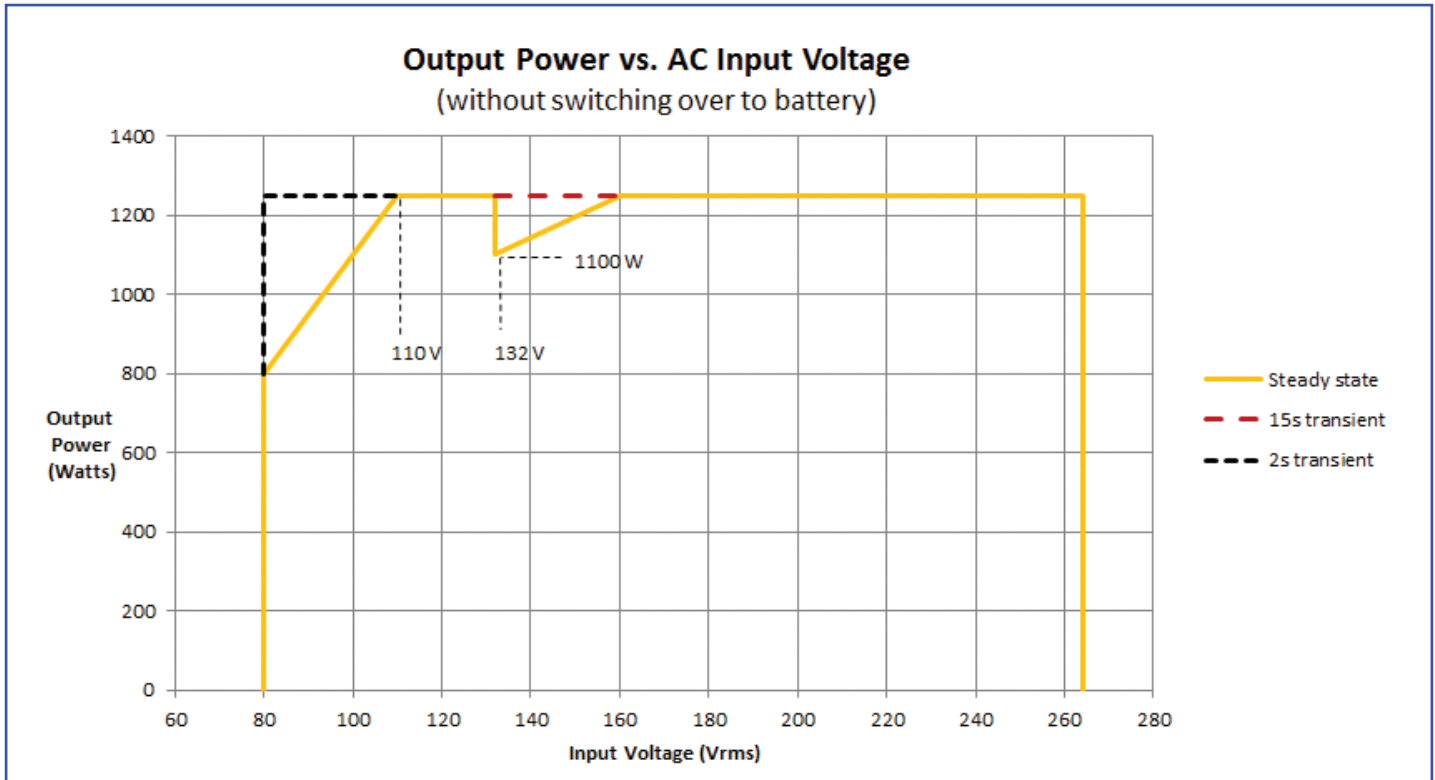

Figure 3

Note that the full rated output power of 1250 W can be derived from the AC INPUT having a voltage within this uncommon range for 15 seconds before the UPS will switch over to the BATTERY PACK. Also note that the UPS can drive it full rated power for a 2 second interval even if the AC INPUT voltage drops below 110 Vrms.

Power Cable Wiring Diagram

Looking at the rear panel, the UPS connector terminals have the following functions and locations:

AC INPUT	
Pin	Function
A	Line
B	Neutral
C	Ground

IEC 320-C14

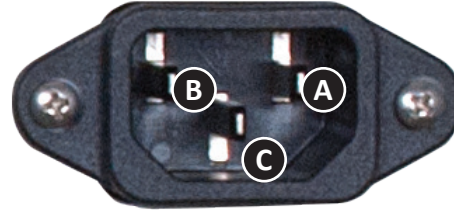

AC OUTPUT	
Pin	Function
A	Line
B	Neutral
C	Ground

NEMA 5-15R (115V)

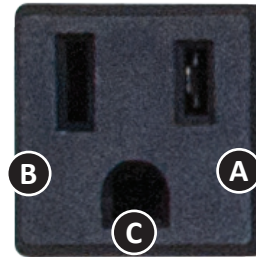

AC OUTPUT	
Pin	Function
A	Line
B	Neutral
C	Ground

TYPE I (ANZ-230V)

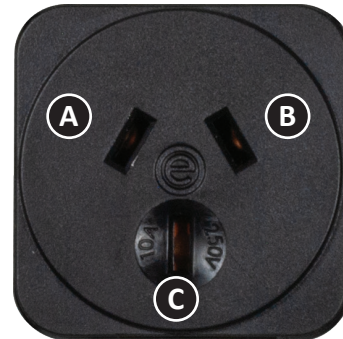

AC OUTPUT	
Pin	Function
A	Line
B	Neutral
C	Ground

TYPE G (UK-230V)

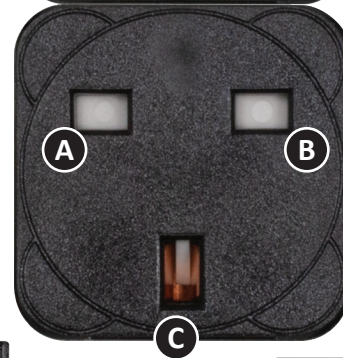

AC OUTPUT	
Pin	Function
A	Line
B	Neutral
C	Ground

TYPE F (EU-230V)

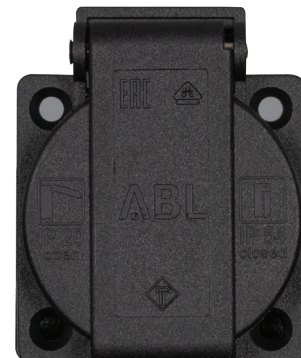
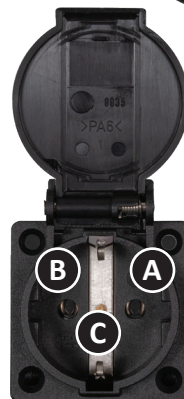

Power Cable Wire Size

SynQor recommends the following cables for use with the UPS-MS-1500 Series:

AC Input: Connector: IEC-60320, C-13, 250 V 15 A

Cable: 3 conductor, 2 pole 3 wire grounding (2P +E), 250 V 15 A, 14 AWG

AC Output: *115 V option*

Connector: NEMA 5-15P, 125 V 15 A

Cable: 3 conductor, 2 pole 3 wire grounding (2P +E), 125 V 15 A, 14 AWG

230 V options

Connector: Type F (EU), Type G (UK), Type I (ANZ)

Cable: 3 conductor, 2 pole 3 wire grounding (2P +E), 250 V 15 A, 14 AWG

AC Output Connector(s) Options:

1 – 4 X NEMA 5-15R (115V)

2 – 1 X Type F (EU-230V)

3 – 1 X Type G (UK-230V)

4 – 1 X Type I (ANZ-230V)

Other options may be available. Contact info@synqor.com or visit the website: <https://www.synqor.com> for more information. If it is necessary to develop custom cables for your application, please read through the following section for some important considerations. Damage caused by improper wiring of cables will not be covered under SynQor's warranty.

Both the input and output cables of the UPS carry substantial current, and since the wires in these cables have resistance the current flowing through them causes a voltage drop from one end of the cable to the other. In other words, the voltage across the cable at its downstream end is smaller than the voltage across the cable at its upstream end. Mathematically, the amount that the voltage drops is equal to the resistance of the cable's wire multiplied by the current flowing through the wire. It is therefore important to make sure that the resistance of the cable's wire is small enough to keep this voltage drop to an acceptably small value.

Set-Up

The recommended procedure for setting up the UPS is the following:

- Insert the BATTERY PACK (if not already present) and tighten its screws.
- Make sure the AC BREAKER on the rear panel of the UPS is in the OFF position.
- Connect the ground wire to the ground stud on the rear panel of the UPS.
- Connect all OUTPUT cables, first to the UPS and then to the various loads.
- Connect the USER I/O cables.
- Connect INPUT cable, first to the UPS and then to the various sources.
- Turn on the source (if they have an upstream breaker).
- Move the AC BREAKER on the rear panel of the UPS to the ON position.

Note: Be careful to not toggle the ON/OFF switch during the setup. Doing so could cause the UPS to turn on and present a hazardous voltage at its output.

Start-Up

- **VERIFY** that all connections to the UPS are correct.
- If the AC source is present and within specifications, the color of the LED above the ON/OFF switch will be amber. This indicates that the UPS is in standby mode and ready to turn on. The battery pack LEDs will also be appropriately illuminated.
- Momentarily push the ON/OFF switch on the front panel of the UPS upward. The switch can then be released and it will return to its normal (neutral) position.
- The UPS will immediately enable its outputs (assuming there is no fault condition). The color of the LED above the ON/OFF switch will change to green. The LEDs on the battery pack will indicate the amount of power being delivered to the load and the input source from which this power is being drawn.

Note: If no input power source is available the UPS can still be turned on. It will draw power from the internal battery for as long as the battery has charge left in it. This is sometimes referred to as a “COLD START” in the industry. Under this condition, the LED above the ON/OFF switch and the battery pack’s LEDs will initially all be off. When the ON/OFF switch is pushed to the ON position, all of these LEDs will be appropriately illuminated.

Shut-Down

- Shut down the equipment connected to the UPS.
- Push the ON/OFF switch on the front panel of the UPS downward and hold it in this position for 1 second (or more). The color of the LED above the ON/OFF switch will change to amber (if the AC input power source is present) or it will be off (if no power source is present). The switch can then be released to return to its normal position.
- The UPS will disable its output and shut down.
- The battery pack LEDs will either be appropriately illuminated (if the AC input power source is present) or they will be off (if no power source is present).
- It is not necessary to move the AC BREAKER on the rear panel of the UPS to the OFF position.

Power Cable Connections/Disconnections While Operating

For safety reasons, it is highly recommended that the input and output power cables be connected to the UPS before the AC power is turned on, and before the UPS is turned on (see **Section I: Warnings** and the **SET-UP** section above). Similarly, it is **highly recommended** to first turn off the UPS and the input power source before any power cables are disconnected from the UPS.

However, the SynQor UPS is capable of having any of its input or output power cables connected at any time (if safely done), including when the UPS is turned on and delivering power to the load. For instance:

- Even if the UPS is turned on, one can connect or disconnect the input power cable without harming the UPS or disrupting power delivery to the load. If no input power source is available, the UPS will draw power from the battery pack.
- Even if the UPS is turned on, one can connect or disconnect an output power cable without harming the UPS or disrupting power delivery to a load that might be connected to the other output.

NOTE that disconnecting an input or output power cable while that cable is handling power will likely cause an arc to form as the terminals are pulled apart. This arcing is not harmful to the UPS, although if done enough times it will degrade the connector to the point where it will need to be replaced.

ALSO NOTE that when the UPS is turned on and delivering power to a load, and then another piece of equipment is connected to one of the output ports, it is possible that this connection will momentarily disrupt the quality of the UPS's output voltage. For instance, consider the case where multiple AC OUTPUTs are connected to multiple loads. If the UPS is turned on and delivering power to several of these loads and then another load is connected to one of the remaining AC output ports, it is possible that this new load will momentarily draw a large surge of current as it starts up. If this happens, the output of the UPS could reach its maximum current limit, and the UPS will reduce its output voltage to keep the current from getting any larger. This reduction in voltage will be corrected once the new load reaches its normal mode of operation, but in the mean time the reduction of the UPS's output voltage might cause one or more of the other loads to malfunction. Whether or not this will be a problem depends on the characteristics of the various loads.

ALSO NOTE Each of the AC output ports is rated for the full UPS-MS-1500 output power capacity. However, the combined sum of all the output power being delivered through the output ports must be less or equal to the full rated power of the UPS-MS-1500 (1250 W).

Cooling System

The SynQor UPS-MS-1500 Series products are cooled by fans that draw air into the intake below the battery pack on the front panel and exhaust it out the two fan ports on the rear panel. Care should be taken to ensure there is no obstruction to this airflow, either at the front intake or the rear exhaust ports. Similarly, care should be taken to avoid obstructing the fan blades.

The speed of the cooling fans is automatically controlled to provide adequate UPS cooling while extending the life of the fan bearings. Under low ambient temperature and/or low UPS output power the fans will be driven at a low speed. If the ambient temperature and output power are such that the UPS cannot otherwise maintain its specified maximum temperature for its internal circuitry, the fans will momentarily be driven at a speed that exceeds their rated long-term running speed. There is an LED on the front panel of the battery pack that indicates the fan status.

If the ambient temperature is low enough (for the level of power being delivered to the load), the fans may not be on. This is not a malfunction. It is done to preserve the life of the fans. If the fans are off, check the Fan Service Required LED on the front panel of the battery pack. If it is GREEN, the fans are functioning properly and simply not needed under the present conditions.

The UPS has two fans to provide redundancy for these exposed, moving components. With only a single operating fan the UPS is still able to deliver 100% rated power at an ambient temperature as high as 40°C, and it is able to deliver 80% of its rated power at an ambient temperature as high as 50°C.





Front Panel Indicators

To indicate the status of the UPS and its battery pack, there is one LED above the ON/OFF switch on the left side of the front panel of the UPS and an additional 16 LEDs on the front panel of the battery pack. There is also an audible alarm. These indicators are described in this section.

LEDs

LED above the ON/OFF switch

This LED has four possible indications, according to the table below:

LED Appearance	Description	Indication
	Green	UPS is Running <i>(Outputs are Enabled)</i>
	Amber	UPS is on Standby <i>(Outputs are Enabled)</i>
	Red	UPS has a Fault Condition
	Off	UPS is Off



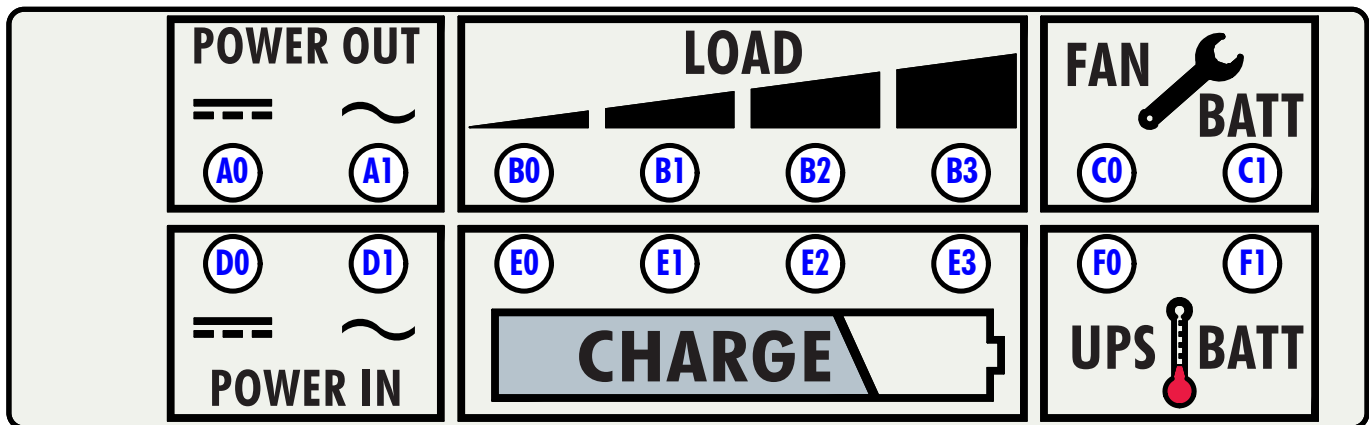

LEDs on the Battery Pack

Each battery pack has 16 LEDs, as shown below, that indicated the status of the battery pack and of the operation of the UPS:







Power-In Indicators (LEDs in positions D0 and D1)

The LED in position D0 indicates the status of the optional DC INPUT (Not Applicable to the UPS-MS-1500) and the LED in position D1 indicates the status of the AC INPUT, according to the table below:

LED Appearance	Description	Indication
	Green	<i>Input is Ready to Provide Load Power</i>
	Pulsing Green	<i>Input is the One Presently Selected as the Source of Power</i>
	Amber	<i>Input has Returned within Range and Diagnostic Tests are Being Performed</i>
	Off	<i>Input is Not within Range</i>

Power-Out Indicators (LEDs in positions A0 and A1)

The LED in position A0 indicates the status of the optional DC OUTPUT (Not Applicable to the UPS-MS-1500) and the LED in position A1 indicates the status of the AC OUTPUT, according to the table below:

LED Appearance	Description	Indication
	Green	<i>UPS is On and the Output Voltage is Within Range</i>
	Amber	<i>UPS is On but the Output Voltage is Out of Range</i>
	Red	<i>UPS is Off and the Output Voltage is Within Range</i>
	Off	<i>UPS is Off</i>

Load Power Indicators (LEDs in positions B0 – B3)

The LEDs in positions B0 through B3 indicate the total output power of the UPS (The AC OUTPUT power) according to the table below:

LED Appearance	Description	Indication
	<i>B0 Dimmed Green; B1-B3 Off</i>	<i>Total Load Power <25%</i>
	<i>B0 Green; B1 Dimmed Green; B2-B3 Off</i>	<i>Total Load Power <50%</i>
	<i>B0, B1 Green; B2 Dimmed Green; B3 Off</i>	<i>Total Load Power <75%</i>
	<i>B0, B1, B2 Green; B3 Dimmed Green</i>	<i>Total Load Power <100%</i>
	<i>B0; B1; B2 Green; B3 Blinking Red</i>	<i>Total Load Power ≥100%</i>





Battery State-of-Charge Indicators (LEDs in positions E0 – E3)

The LEDs in positions E0 through E3 indicate the state-of-charge of the internal battery pack, as well as whether the battery pack is on standby or being charged (**Blinking Amber**) or discharged (**Blinking Red**), according to the table below.

LED Appearance			Indication
Standby	Discharging	Charging	
	NA	NA	<i>Battery Charge <10%</i>
			<i>Battery Charge <25%</i>
			<i>Battery Charge >25%</i>
			<i>Battery Charge >50%</i>
			<i>Battery Charge >75%</i>
	NA	NA	<i>Battery Charge =100%</i>
	NA	NA	<i>Battery Charge =100% (Cell Balancing is Occurring)</i>





UPS Cooling System Indicator (LED in position F0)

The LED in position F0 indicates the temperature and status of the cooling system for the UPS according to the table below:

LED Appearance	Description	Indication
	Green	<i>Moderate UPS Temperature (Fans Running at 33%)</i>
	Blinking Green	<i>Warm UPS Temperature (Fans Running at 67%)</i>
	Amber	<i>Elevated UPS Temperature (Fans Running at 100%)</i>
	Red	<i>Maximum UPS Temperature (Fans Running at 110%)</i>



Battery Pack Temperature Indicator (LED in position F1)

The LED in position F1 indicates the temperature of the battery pack (and its availability to be charged or discharged because of its temperature) according to the table below:

LED Appearance	Description	Indication
	Blinking Red	<i>Battery is too Cold to be Charged or Discharged</i>
	Blinking Amber	<i>Battery is too Cold to be Charged</i>
	Green	<i>Battery Temperature is Within its Specified Operating Range</i>
	Amber	<i>Battery is too Hot to be Charged</i>
	Red	<i>Battery is too Hot to be Charged or Discharged</i>



Fan Service Required Indicator (LED in position C0)

The LED in position C0 indicates whether the two cooling fans in the rear panel of the UPS are OK or if their performance is degraded, according to the table below:

LED Appearance	Description	Indication
	Green	<i>Both Fans are OK</i>
	Amber	<i>One or Both Fans Have Recently Had Degraded Performance and Diagnostic Tests are Being Performed</i>
	Red	<i>One or Both Fans Presently Have Degraded Performance</i>

Battery Pack Service Required Indicator (LED in position C1)

The LED in position C1 indicates whether the battery pack is OK or if its storage capacity has been degraded compared to its rated value, according to the table below:

LED Appearance	Description	Indication
	Green	<i>Battery Pack is OK</i>
	Amber	<i>Battery Pack's Calculated Maximum Storage Capacity is <75% of its Rated Value</i>
	Red	<i>Battery Pack's Calculated Maximum Storage Capacity is <50% of its Rated Value</i>

Audible alarm

For critical situations a pattern of audible tones will be repeated every 5 seconds, according to the table below. This audible alarm can be **silenced** by holding the ON/OFF switch on the front panel in the “UP” position until a chirp is heard. A new alarm condition will cause the audible alarm to be reactivated. Contact Factory for instructions on how to permanently silence the alarm.

Number of Tones in Pattern	Indication
One	<i>UPS is Drawing Power From the Battery Pack</i>
Two	<i>Load Power is greater than or approaching 100% Rated Power</i>
Three	<i>Fault Appears on the AC Output UPS Must be Turned Off and Back On to Reset Fault</i>
Four	<i>UPS is Drawing Power From the Battery Pack and the Remaining Charge is <10%</i>

Hot Swapping the Battery Pack

The battery pack can be removed from the UPS and it, or another one, can be inserted into the UPS without disrupting the delivery of power to the load as long as a source of input power is available. This feature is referred to as “hot swapping” in the industry. It can be used to replace a battery pack that needs servicing, or to replace a drained battery pack with a spare, fully charged one if additional back-up protection must be ensured before the drained battery pack will have time to be recharged.

Of course, if there is no source of input power available and the UPS is therefore drawing power from the battery, then the removal of the battery pack would cause the UPS’s outputs to shut down until a recharged battery pack is inserted.

Operating Environment

The SynQor UPS-MS-1500 Series is designed for enclosed environmental conditions for military, aerospace and commercial applications. All the electronic circuitry and the battery pack are contained in a ultra-sturdy, environmentally resistant, shock-proof chamber. Protection circuitry ensures that the battery is not charged or discharged if it is too hot or too cold. The UPS-MS-1500 will shut down if it is too hot.

The UPS-MS-1500 (with cables connected and the battery pack installed) has been qualified to the following requirements of MIL-STD-810G:

MIL-STD-810G Test Method	Name	Procedure	Details
500.5	Low Pressure	I, II and III	<ul style="list-style-type: none"> ▪ 15,000 ft. operating ▪ 40,000 ft. storage
501.5	High Temperature	I and II	<ul style="list-style-type: none"> ▪ +50°C operating ▪ +65°C storage
502.5	Low Temperature	I and II	<ul style="list-style-type: none"> ▪ -10°C operating ▪ -10°C storage
503.5	Temperature Shock	I	<ul style="list-style-type: none"> ▪ 10 cycles; >10°C/minute
507.5	Humidity	NA	<ul style="list-style-type: none"> ▪ >95%
514.6	Vibration	Category 24	<ul style="list-style-type: none"> ▪ PSD = 0.04 g²/Hz; 20-2000 Hz ▪ Operating
516.6	Shock	I	<ul style="list-style-type: none"> ▪ 20 g/20 ms

Battery Technology

The battery packs for the UPS-1500 Series contain Lithium Ion rechargeable batteries. For a given amount of energy storage they are much smaller and lighter than a lead-acid battery. They are capable of very high discharge rates and fast recharging, and can do so over many cycles and over a long life. As such they are very suitable for a UPS application. Lithium Ion batteries are used in many military applications.

Electronic Circuitry within the Battery Pack

The SynQor battery pack has electronic circuitry within it that:

- controls the charging (including the equalization charging) of the battery
- separates the battery cells into multiple segments
- provides protection of the battery
- runs diagnostics on the battery
- controls the battery pack's front panel LED indicators

The purpose of separating the battery cells into multiple segments is to allow the battery pack to remain useful even if one of its battery cells fails. In a normal battery configuration, the failure of a single cell would disable the entire battery. The SynQor battery packs are designed with their battery cells arranged in segments that can be disconnected from the other segments by the internal electronic circuitry. Therefore, if a battery cell fails in one segment, the battery pack can still operate with the remaining segments (at a reduced battery run-time) until the battery pack can be serviced.

There are two battery packs offered for the SynQor UPS-MS-1500 products: BAT-0200-S and BAT-0400-H. These packs have 3 and 4 battery segments, respectively. The BAT-0200-S and BAT-0400-H batteries are applicable to the UPS-MS-1500-[S,H]-2U.

The protection features provided by the electronic circuitry include:

- **Maximum Current Limit** when the battery is being charged/discharged
- **Charging/Discharging Protections** to avoid over-charging/discharging of the battery
- **Charging/Discharging Lockout** if the battery is too hot or too cold
- **Disconnect** of the battery from the battery pack's terminals when the pack is not inserted into the UPS

Battery Capacity

SynQor offers multiple battery packs in a sub-1U high form factor, the BAT-0200 and the BAT-0400. The BAT-0200 weighs 10 lbs. and has 3 battery segments. The BAT-0400 weighs 11.8 lbs. and has 4 battery segments. All battery packs will recharge in about two hours. The run-time as a function of UPS load power is shown on the below table.



Total UPS Output Power	BAT-0200-S Run-Time	BAT-0400-H Run-Time
100% Rated Power	> 10 Minutes	> 13.5 Minutes
80% Rated Power	> 13 Minutes	> 18 Minutes
50% Rated Power	> 21 Minutes	> 27 Minutes

Storage of the Battery Pack

The storage temperature range of the battery pack is -40°C to +65°C (-40°F to +150°F). Long term storage outside this temperature range will lead to a permanent reduction in the battery’s energy storage capacity. The optimal storage temperature is below 35°C. Storage above this temperature will accelerate battery degradation.

Battery Pack Replacement

UPS-MS-1500-S-2U product ships with the BAT-0200-S battery pack. UPS-MS-1500-H-2U product ships with the BAT-0400-H battery pack. However, the two packs are interchangeable; for example, a BAT-0400-H battery may be installed in an existing UPS-MS-1500-S-2U device as an upgrade to the performance.

UPS Series	BAT-0200-S	BAT-0400-H
UPS-MS-1500-[S,H]-2U	Qty. 1	Qty. 1

Always use the proper SynQor battery pack.

Handling the Battery Pack

The operating temperature range of the battery pack is -20°C to +55°C (-4°F to +130°F). The battery pack's internal electronic circuitry will disable the battery if the cell temperatures are outside this temperature range. The SynQor UPS is equipped with internal battery heaters which activate to keep the cells above 0°C in cold ambient temperatures.

When the battery pack is not inserted into the UPS, the internal electronic circuitry disconnects the battery from the pack's power terminals. Nevertheless, care should be taken to avoid making metal contact with (or between) any of these terminals.

The battery pack has its own aluminum chassis that protects its battery cells and internal electronic circuitry from the environment when the pack is not inserted into the UPS. However, care should be taken to ensure this chassis and the exposed power terminal strip is not subjected to extreme mechanical shock or to excessive moisture.

UPS battery packs must be shipped per Federal DOT Regulations as a Class 9 Fully Regulated Hazardous Material. The battery pack must not be installed in the UPS when being shipped, and it must be packaged in the original SynQor Shipping Carton (including inner protective inserts) which has been approved for shipping this product. The shipping carton must be appropriately labeled per applicable Federal DOT Requirements. A UPS may be shipped using standard shipping methods if it does not contain a battery pack. Please contact SynQor for further assistance.

The battery pack should be disposed in accordance with applicable regulations of the locality or returned to a factory-authorized Service Center.

Emergency response contact information for battery damage, leaks, smoke, or fires can be found at the following link: <https://www.SynQor.com/UPS/documents/Contact.pdf>. Please contact the SynQor factory for all other questions regarding the UPS battery pack.

CAUTION: Do not dispose of batteries in a fire. The batteries may explode.

CAUTION: Do not open or mutilate batteries. Released electrolyte is harmful to the skin and eyes. It may be toxic.

Always use the proper SynQor battery pack. See the battery replacement chart on page 27.

Control Cable Connections

There are two high-density (three-row) DB15 connectors located on the rear panel of the UPS:

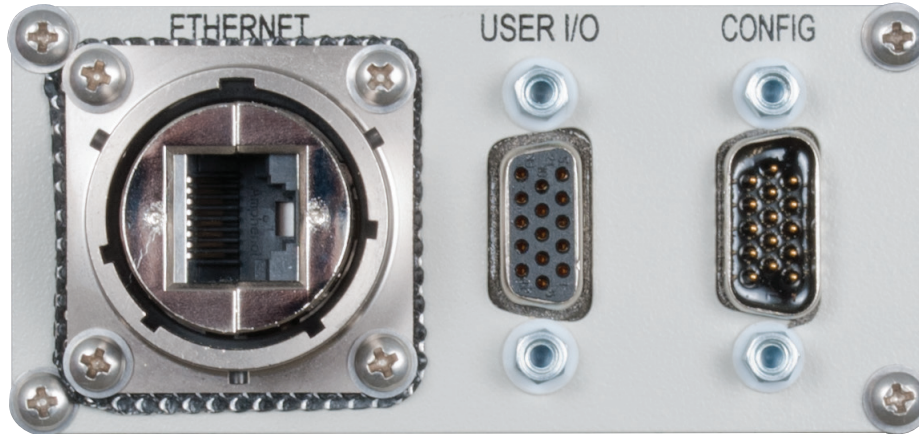

The User I/O female DB15 connector on the left is for an optional connection to a host/system computer so that it can control the UPS and receive information regarding the status of the UPS.

The Configuration male DB15 connector is not applicable to this model UPS. Nothing should be connected to this DB15 connector.

The designation/location of the pins for the User I/O female high-density DB15 connector is shown below:

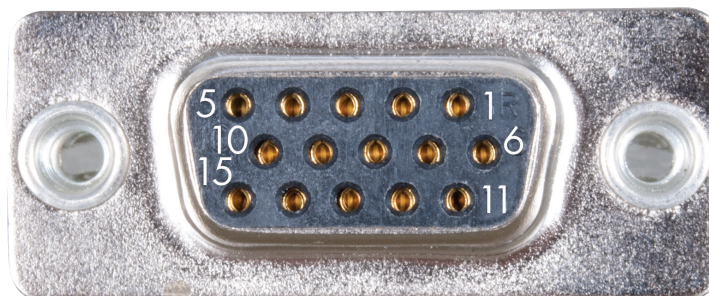

Internal User I/O Circuits

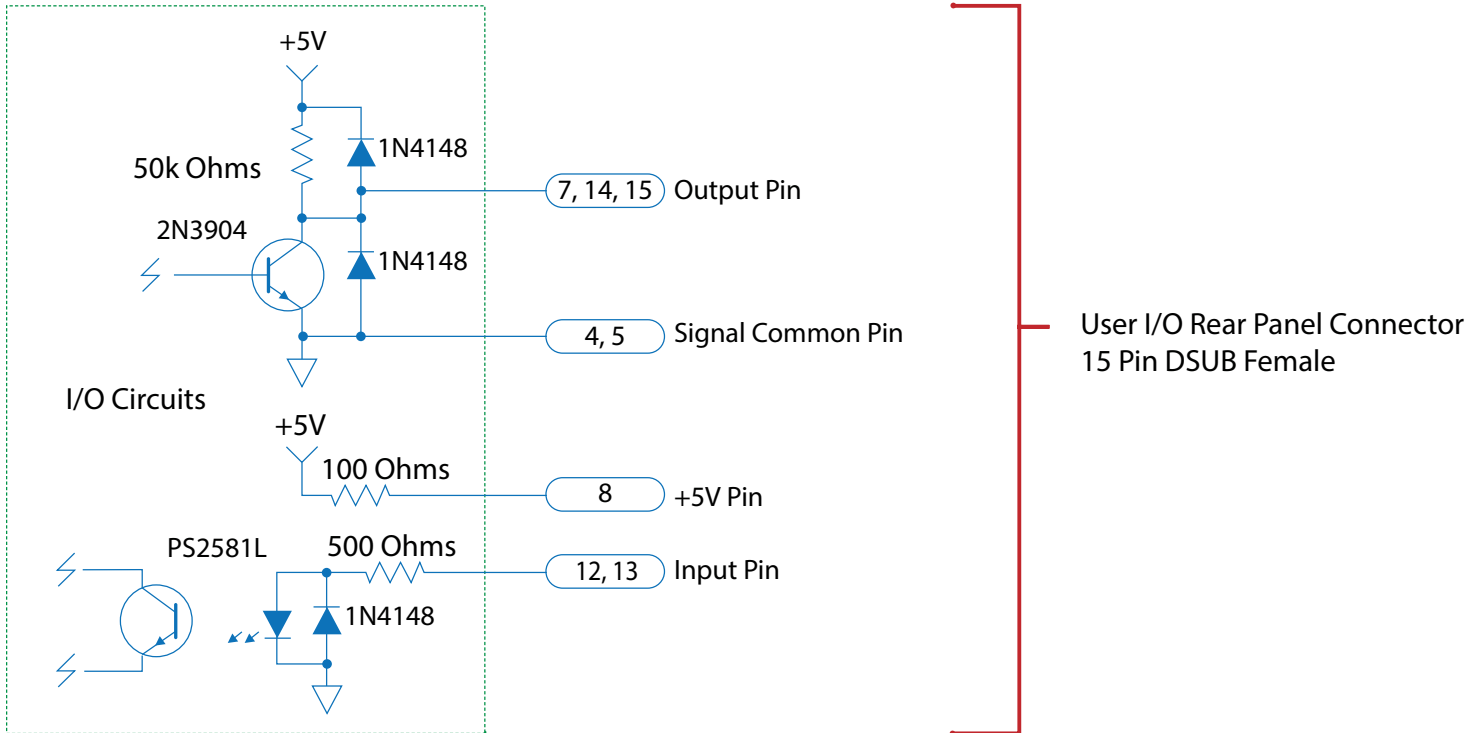

Remote On/Off Switch Connections

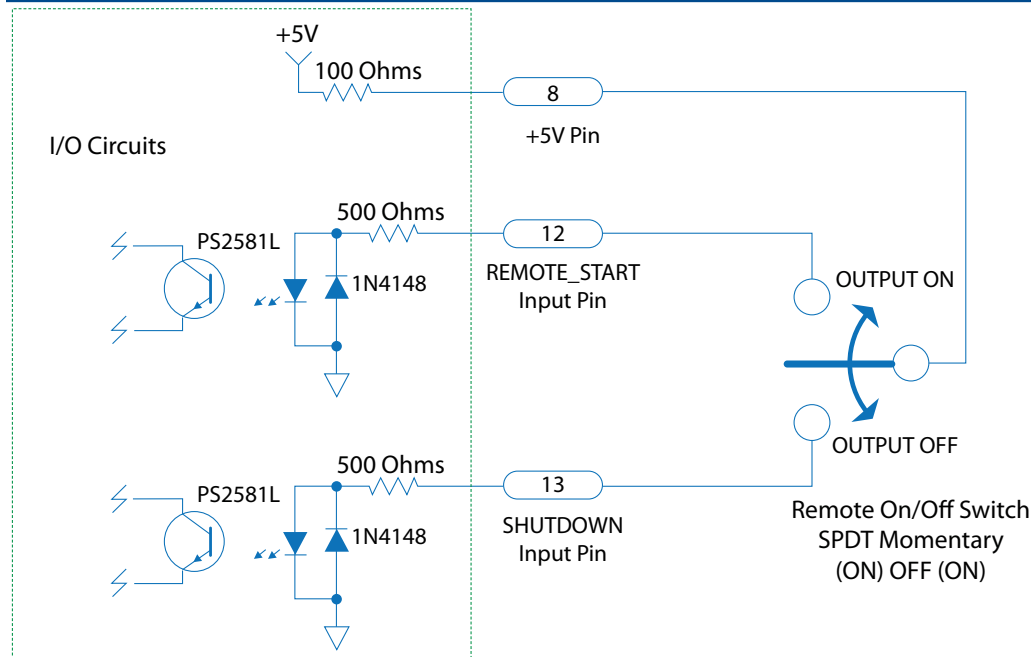

Note: A 2PDT or 3PDT switch may be substituted for single control of 2 or 3 UPS machines, respectively.

Digital Input/Output Control Signals

There are 2 input and 5 output digital signals available on the User I/O female high-density DB15 connector. The pin assignments and functions of these digital I/O signals are as follows:

Signal	Pin Number	Function
+5 V	8	Bias voltage with minimal current drive usable as a pull-up voltage for the open collector output signals (100Ω source resistance)
GND	4 and 5	Ground reference for all digital inputs and outputs
$\overline{\text{LOW_BATT}}$	6	Open collector* output where “low” indicates battery charge level is <10%
$\overline{\text{ACIN_GOOD}}$	7	Open collector* output where “low” indicates AC Input voltage is within range
$\overline{\text{ON_BATT}}$	9	Open collector* output where “low” indicates the UPS is drawing power from its battery
$\overline{\text{OUT_OK}}$	14	Open collector* output where “low” indicates AC Output voltage is within range
$\overline{\text{OVER_TEMP}}$	15	Open collector* output where “low” indicates that the UPS is at or above its maximum temperature
REMOTE_START	12	Drive this line “high” with $\geq 5\text{mA}$ to enable the UPS outputs
SHUTDOWN	13	Drive this line “high” with $\geq 5\text{mA}$ to disable the UPS outputs

*With an internal 50 kΩ Pull-up Resistor to 5 V and ESD Protection Diodes.

RS232 Serial Interface

The same User I/O female high-density DB15 connector also provides for an RS232 interface between the UPS and the host/system computer. The interface has a 115.2k baud with eight data bits, no parity bit and one stop bit. The pin assignments and functions for this RS232 interface are as follows:

Signal	Pin Number	Function
GND	4 and 5	Ground reference for RX and TX signals
RX	3	RS232 DCE/UPS Device Receive signal
TX	2	RS232 DCE/UPS Device Transmit signal

The RS232 port provides readback of UPS’s state, as well as the configuration and control of the UPS’s operation. The port can be used from a standard terminal interface, or from a custom computer application.

Readback information that is available:

- AC Input Voltage
- AC Input Current
- AC Input Frequency
- AC Output Voltage
- AC Output Current
- AC Output Power
- AC Output Frequency
- Total Output Power
- Battery Voltage
- Battery State of Charge
- Battery Predicted Run Time
- Number of Battery Cycles
- Fan RPM
- Internal Temperatures

Parameters that are controllable through the interface:

- Output enable / disable
- Fan diagnostics
- Alarm enable / disable

For a detailed description of the terminal interface see the SynQor website at:

https://www.SynQor.com/UPS/documents/UPS_User_Commands.pdf

Ethernet Interface

The Ethernet interface provides a web page based user interface for monitoring and control of the UPS. The user can configure email alerts for UPS alarm conditions. The interface also exposes an SNMP interface compliant to RFC-1628.

The Ethernet interface supports 10BASE-T and 100BASE-T standards. It utilizes a standard RJ-45 connector, also allowing a metallic sealable circular military outer housing. The interface supports auto-negotiation, polarity correction, and Auto-MDIX (detection and use of straight through or cross-over cables).

IP address assignment can be done via DHCP or user entry of a static address. The interface also supports a direct connection between the UPS and a host computer by including a DHCP server internal to the UPS.

For a detailed description of the Ethernet port and SNMP implementation see the SynQor website at: https://www.synqor.com/ups/documents/UPS_Ethernet_SNMP_UG.pdf

Battery

The lithium ion battery cells in the battery pack do not need any maintenance. In particular, unlike a lead acid battery a lithium ion battery does not need to re-charged on a regular basis to avoid degradation of its energy storage capacity. Care should only be taken in ensure that batteries are not stored at a temperature outside their specified storage temperature range of -40°C to +65°C (-40°F to +150°F) when stored separate at a different location than the UPS-MS-1500 storage location. The storage temperature when batteries stored inside the UPS-MS-1500 or at the same location is -10°C to +65°C (14°F to +150°F).

Emergency response contact information for battery damage, leaks, smoke, or fires can be found at the following link: <https://www.SynQor.com/UPS/documents/Contact.pdf>. Please contact the SynQor factory for all other questions regarding the UPS battery pack.

CAUTION: Do not dispose of batteries in a fire. The batteries may explode.

CAUTION: Do not open or mutilate batteries. Released electrolyte is harmful to the skin and eyes. It may be toxic.

Always use the proper SynQor battery pack. See the battery replacement chart on page 27.

Fans

The fans on the rear panel have sealed bearings that do not require any maintenance.

Cleaning

The UPS-MS-1500 unit has an environmentally resistant chamber for its electronics and the battery pack. Care should be taken not to get liquids into the unit or on the connector terminals. If liquids do fall on the connectors or UPS use a soft cloth to remove the foreign liquid. The presence of water or any other liquid on or inside the UPS could damage the internal electronics. Do not immerse the unit in water for cleaning.

Fault Conditions

The SynQor UPS has no user-serviceable parts within it. If it has an internal malfunction only a factory trained personnel should attempt to repair it.

There are, however, several external conditions that could cause the UPS to not operate as desired. These external conditions can likely be corrected by the user.

The 16 LEDs on the front panel of the battery pack are the best and first place to look to determine what might be wrong with the UPS. The table on the next several pages is therefore organized by what these LEDs indicate, and for each indication there is a listing of what might possibly be wrong.

The front panel battery pack LED array is shown below. The designations of the 16 LEDs in this array are used in the following table.

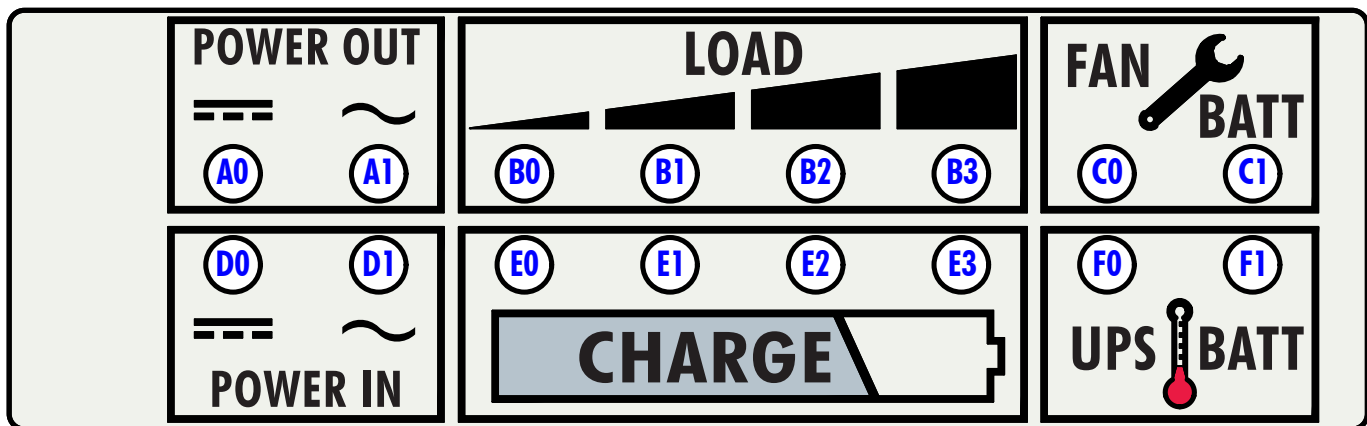

LED	Indication	Possible Problem(s)
D1: AC INPUT Power LED	LED is OFF	<ul style="list-style-type: none"> •The AC INPUT power source is not turned on. •The AC INPUT cable is not connected or it is wired wrong. •The AC Breaker on the rear panel is OFF. •The AC INPUT voltage is either too low or too high.
	LED is a STEADY GREEN and not a PULSING GREEN. UPS is instead running off the BATTERY	<ul style="list-style-type: none"> •The AC INPUT voltage is within its proper range but the UPS is not selecting it for its source of power. •The AC INPUT voltage and the total load power may exceed the power derating curves given earlier in this Guide. •The AC INPUT cable may have too much series resistance. Thicker wire should be used.
D0: DC INPUT Power LED	LED is OFF (Normal)	<ul style="list-style-type: none"> •Option is not available on the UPS-MS-1500 .
A1: AC OUTPUT Power LED	LED is OFF	<ul style="list-style-type: none"> •The UPS is OFF and needs to be turned ON.
	LED is AMBER	<ul style="list-style-type: none"> •The AC OUTPUT load is higher than 1250 W or 1500 VA by enough to trigger the power limit circuitry. •The AC OUTPUT load crest factor is too high. •The AC OUTPUT is shorted within the cable or a load. •Some other source of power is connected to the AC OUTPUT.
	LED is RED	<ul style="list-style-type: none"> •The UPS has been turned OFF, but due to a malfunction within the UPS it is still running and providing an AC OUTPUT voltage. •Some other source of voltage is connected to the AC OUTPUT and is powering it when the UPS is not.
A0: DC OUTPUT Power LED	LED is OFF (Normal)	<ul style="list-style-type: none"> •Normal. Option is not available on the UPS-MS-1500 .

LED	Indication	Possible Problem(s)
B0 – B3: LOAD POWER LEDs	B3 is BLINKING RED	<ul style="list-style-type: none"> • Total UPS load power is greater than or approaching 1250 W. The UPS may still be delivering its specified output voltage because the load power is not high enough to trigger the power limit circuitry.
	B0 – B3 are all OFF	<ul style="list-style-type: none"> • No power is being delivered to the load. • The UPS is OFF and needs to be turned ON. • The loads or output cables are not connected. • The loads are all turned off. • The loads are simply not drawing any appreciable power at the time.
F0: UPS Cooling System LED	LED is BLINKING GREEN	<ul style="list-style-type: none"> • Indicates that the fans are running at 67% of their rated speed. There is no problem.
	LED is AMBER	<ul style="list-style-type: none"> • Indicates that the fans are running at 100% of their rated speed. There is no problem, but the unit is operating at a high ambient temperature and a high load combination.
	LED is RED	<ul style="list-style-type: none"> • Fans are running at 110% of rated speed to keep the unit cool. The maximum recommended temperature may be exceeded, but the fans are keeping things cool enough to avoid triggering the over-temperature shut-down circuitry.
F1: Battery Pack Temperature LED	LED is BLINKING RED	<ul style="list-style-type: none"> • The battery is too cold to be charged or discharged without damage. • If the UPS is running from the AC INPUT or the battery will eventually be warmed up and this condition will go away.
	LED is BLINKING AMBER	<ul style="list-style-type: none"> • The battery is too cold to be charged without damage, but it can be discharged if the UPS needs to draw power from it. • If the UPS is running from the AC INPUT, the battery will eventually be warmed up and this condition will go away.
	LED is STEADY AMBER	<ul style="list-style-type: none"> • The battery is too hot to be charged without damage, but it can be discharged if the UPS needs to draw power from it. • If the ambient temperature is within its specified range the battery will eventually cool down and this condition will go away.
	LED is STEADY RED	<ul style="list-style-type: none"> • The battery is too hot to be charged or discharged without damage. • If the ambient temperature is within its specified range the battery will eventually cool down and this condition will go away.

LED	Indication	Possible Problem(s)
C0: Fan Service Required LED	LED is AMBER	<ul style="list-style-type: none"> •One or both fans have recently had degraded performance but seem to be OK now. The UPS is running a diagnostic test.
	LED is RED	<ul style="list-style-type: none"> •One or both fans presently have degraded performance, even if they are running, and service is recommended at the earliest convenient time. •Ensure that the fan blades are not obstructed from turning
C1: Battery Pack Service Required LED	LED is AMBER	<ul style="list-style-type: none"> •The battery pack’s calculated maximum energy storage capacitor is <75% of its rated value. The UPS’s battery run-time will therefore be similarly reduced. •The battery pack should be replaced at the earliest convenient time if this derated battery run-time is unacceptable.
	LED is RED	<ul style="list-style-type: none"> •The battery pack’s calculated maximum energy storage capacitor is <50% of its rated value. The UPS’s battery run-time will therefore be similarly reduced. •The battery pack should be replaced at the earliest convenient time.
All 16 LEDs:	All LEDs are OFF	<ul style="list-style-type: none"> •The battery pack is not fully inserted into the UPS with its thumb screws tightened. •The terminal on the battery pack is damaged or dirty. •The battery pack is defective and needs to be replaced.
Audible Alarm: (Pattern repeats every 5 seconds)	One tone	<ul style="list-style-type: none"> •The UPS is drawing power from the battery pack and is discharging it. •Sources of power should be restored or preparations made to shut down the loads
	Two tones	<ul style="list-style-type: none"> •The total UPS load power is above 1250 W. •Loads should be reduced if this condition persists.
	Three tones	<ul style="list-style-type: none"> •The AC OUTPUT has experienced either a short circuit or a load having a start-up surge current characteristic that the UPS could not start. The AC OUTPUT has therefore turned OFF. •To reset, the UPS must be turned OFF and then ON.
	Four tones	<ul style="list-style-type: none"> •The UPS is drawing power from the battery pack and its remaining charge is <10% of its rated charge. •Sources of input power should be restored or the loads should be shut down.

Two other conditions should be mentioned:

- The fans are off when the UPS is running

It is normal for the fans to be off, even if the UPS is running and delivering power to the load, as long as the temperature of the UPS is low enough. If the Fan Service Required LED (C0) is green, both of the fans are OK, even if they are not running.

- The UPS does not turn off when the ON/OFF switch is pushed down

When the ON/OFF switch on the front panel is pushed down, the UPS does not respond to this signal for approximately 1 second. This is done to ensure that the UPS is not accidentally turned off. If the user does not hold the ON/OFF switch in the OFF position for a full second before releasing it, the UPS will not turn off.

Other possible situations that are the result of external issues that a user could likely correct are related to:

- Loads that draw a large surge of current at start-up

Some AC loads draw a very large amount of current when an input voltage is first applied to them. This might happen when the UPS is first turned on if the load is already connected to the UPS. Or it may happen when the load itself is turned on and/or connected to the AC OUTPUT of a UPS that is already running. Common examples of such loads are motors and incandescent lights, but some electronic equipment can also display this characteristic.

Several problems could arise with such a load:

- The UPS fails to start the load:

The SynQor UPS is designed to try various start-up routines when it is first turned on to overcome the problem of surge currents with some loads. There are five such routines (or repetitions of a given routine) that are tried. If the load is not started after these five routines are attempted, the UPS will turn OFF. To get the UPS to try again, the user should again push the ON/OFF switch on the front panel to the ON position.

If there is more than one load of the AC OUTPUT that displays this start-up surge characteristic, and the UPS is not capable of starting with all of them connected and switched on, it may be possible to switch on each load in turn. For instance, if the UPS cannot start up with a load consisting of a large bank of incandescent lights, then it may be able to start if various sections of the lights are switched on in sequence.

- A newly started load disturbs the existing UPS loads.

A common problem can occur when the UPS is running and powering one or more loads connected to its AC OUTPUT, and then an additional load of the AC OUTPUT is turned on. If this newly started load draws a large surge current at start-up, it can cause the current limit of the UPS's AC OUTPUT to be triggered, and the AC OUTPUT voltage will then drop. This drop could cause the existing loads to be disturbed. Furthermore, if the voltage drops far enough, the UPS will turn off its AC OUTPUT and initiate a new start-up sequence (after 0.1 seconds). This latter action would cause the power flow to the existing loads to be interrupted.

If this disruption of existing loads is a problem, then the solution is to make sure the loads that display this start-up surge characteristic are all started first, or that all loads are started at the same time.

- Cable wire resistance is too high:

As mentioned in the section “Power Cables Wire Size”, the resistance of a power cable’s wires gives a voltage drop from the upstream to the downstream end of the cable. This voltage drop, if large enough, will cause the either UPS to determine that the voltage at its AC INPUT is below its minimum specified value, even though the corresponding voltage at the source is within the specified range.

The phenomenon that may be displayed is the following.

- Assume the AC INPUT source is present.
- The UPS, before it turns on, does not draw any power or current from the AC INPUT, and therefore the voltage drop across the AC INPUT cable is zero.
- The UPS sees that the voltage at the AC INPUT is within its specified range, and enables its outputs.
- As the load then draws power, the UPS begins to draw current from the AC INPUT cable. This current causes a voltage drop to appear across the cable.
- If the voltage at the AC source is close to, but still above, its 80 Vrms minimum, but the voltage drop across the cable is large enough for the voltage at the AC INPUT of the UPS to fall below 80 Vrms, then the UPS will determine that the AC INPUT is out of range and will switch over to drawing power from the internal Battery Pack.
- Since the UPS no longer draws current from the AC INPUT, the voltage drop across the AC INPUT cable goes back to zero volts.
- After a while, the UPS decides the AC INPUT voltage is back within its proper range, and begins to draw a current from the AC INPUT.
- The cycle above repeats itself for a total of three times, at which point the UPS stops trying to draw power from the AC INPUT for one minute. After this one minute another set of 3 cycles are repeated, followed by another stop for one minute, and so on.

The solution to this problem is to make sure that the cable has wires of sufficient diameter, or “gauge” for the length of the cable. The longer the cable, the bigger diameter the wire should have.

See the section “Power Cable Wire Size” for recommended cable wire sizes.

UPS **MILITARY** **SHELTER-GRADE**

UNINTERRUPTIBLE POWER SUPPLY

Operator's Guide *UPS-MS-1500 Series*



SynQor, Inc.
9 Northeastern Boulevard
Suite 200
Salem, NH 03079
Phone: 1 (603) 541-4141
E-mail: power@synqor.com
www.SynQor.com



Made in USA

SynQor[®]
Advancing The Power Curve[®]