

MPS MILITARY FIELD-GRADE

MILITARY POWER SUPPLY

Operator's Guide MPS-4000 Series & MPPS-4000 Series



Made in USA



MPS-4000-1U



MPPS-4000-1U

SynQor

Advancing The Power Curve®

Table of Contents

SECTION I

WARNINGS

<i>Hazardous Voltages</i>	4
<i>Hazardous Energies</i>	5
<i>Protection from the Environment</i>	5
<i>User Serviceable Parts</i>	5

SECTION II

GENERAL PRODUCT INFORMATION

<i>Product Description</i>	6
<i>Product Topology: MPS</i>	7
<i>Product Topology: MPPS</i>	8
<i>Part Numbering Scheme and Options: MPS</i>	9
<i>Part Numbering Scheme and Options: MPPS</i>	10
<i>Product Specifications</i>	11
<i>Technical Specifications: MPS</i>	12
<i>Technical Specifications: MPPS</i>	13
<i>Programmable Features: MPPS</i>	13
<i>Technical Specifications: MPS & MPPS</i>	14
<i>1U Mechanical Diagram</i>	15
<i>Efficiency: MPS</i>	16
<i>Total Output Power: MPS</i>	17
<i>Temperature Derating: MPS</i>	18
<i>Efficiency: MPPS</i>	19
<i>Output Power Derating: MPPS</i>	20
<i>Total Output Power: MPPS</i>	23
<i>MPS Droop Characteristics - All Output Voltages</i>	24
<i>MPPS Overload Characteristics</i>	25
<i>Power Cable Wiring Diagram</i>	26

SECTION III

OPERATION

<i>Set-Up</i>	27
<i>Start-Up</i>	27
<i>Shut-Down</i>	27
<i>Power Cable Connections</i>	28
<i>Programming The Output: MPPS Only</i>	29
<i>Programming the Output From the Web Interface</i>	29
<i>Programming the Output From the RS-232 Interface</i>	30
<i>Cooling System</i>	31
<i>Front Panel Indicators</i>	32
<i>Operating Environment</i>	36

SECTION IV

CONTROL INTERFACE DETAILS

<i>Control Cable Connections</i>	37
<i>Internal User I/O Circuits</i>	38
<i>Remote On/Off Switch Connections</i>	38
<i>Digital Input/Output Control Signals</i>	39
<i>RS232 Serial Interface</i>	39
<i>Ethernet Interface</i>	40
<i>Synchronized Operation of Multiple Units: MPS</i>	41
<i>Turn-On, Turn-Off, Restart Control:</i>	41
<i>Fault Synchronization Control:</i>	41
<i>Parallel Operation of Multiple Units: MPPS</i>	42
<i>Turn-On, Turn-Off, Restart Control:</i>	42
<i>Parallel Operation, Current sharing:</i>	42

SECTION V

MAINTENANCE

<i>Fans</i>	43
<i>Cleaning</i>	43

SECTION VI

TROUBLE-SHOOTING GUIDE

<i>Fault Conditions</i>	44
-------------------------------	----



Hazardous Voltages

The **INPUT AND OUTPUT POWER** connectors and cables of the SynQor MPS/MPPS may have voltages that are unsafe. **INJURY OR DEATH ON CONTACT** may result. Appropriate safety precautions should be taken. All connections should be made in accordance with **LOCAL ELECTRICAL CODES**.

- The **CHASSIS** should be connected to earth or system ground with Ground Stud on the rear panel, see mechanical diagrams.
- For the **AC INPUT** cable and connector:
 - Do not assume that a hazardous voltage is not present at the terminals of the AC input connector, even if the MPS/MPPS appears to be off.
 - Do not make contact with the terminals of the AC input connector.
 - Always connect the cable to the MPS/MPPS before it is connected to the source of AC power.
 - Always disconnect the AC input cable from the source of AC power before disconnecting it from the MPS/MPPS.
 - If the AC input cable is connected to the source of AC power and not connected to the MPS/MPPS, do not contact the exposed terminals of the AC input cable.
 - Do not assume that the source of AC power is not present.
 - Connections between the AC input cable and the source of AC power should not be accessible.
- For the **MPPS DC OUTPUT** cable and connector:
 - The DC output terminals of the MPPS may be hazardous, depending on the model and user commanded voltage. Never assume the terminals of the DC output connector or the wires of the DC output cable are safe to contact, even if the MPPS appears to be off.
 - The DC output terminals of the MPPS are isolated from the AC input with reinforced safety insulation.
- For the **MPS DC OUTPUT** cable and connector:
 - The rated DC output voltage of the MPS is below the level considered hazardous.
 - The DC output terminals of the MPS are isolated from the AC input with reinforced safety insulation.
 - However, never assume the terminals of the DC output connector or the wires of the DC output cable are safe to contact, even if the MPS appears to be off.

Hazardous Energies

The **INPUT AND OUTPUT POWER** connectors and cables of the SynQor MPS/MPPS may be the source of high levels of energy. Do not inappropriately make electrical contact between any terminal of a connector and another, or between any wire of a cable and another, or between any terminal or wire and the MPS/MPPS Unit's chassis or ground. **DAMAGING ELECTRICAL ARCS** may result. Care should be taken to avoid accidental electrical contacts of this sort.

Protection from the Environment

The SynQor MPS/MPPS is a ruggedly built product having its electronics contained in a sealed chamber. It is capable of withstanding harsh levels of mechanical acceleration, shock and vibration, temperature and pressure variations, and exposure to water, salt, sand and dust within the levels specified in the data sheet. **THESE LEVELS SHOULD NOT BE EXCEEDED.**

Do not obstruct the air intake in the front of the MPS/MPPS or the fan exhausts in the rear panel of the MPS/MPPS while the MPS/MPPS is operating.

User Serviceable Parts

MPS/MPPS-4000 fans are user replaceable with kits available from SynQor. Please contact the SynQor factory for obtaining fan replacement kits and instructions (Replaceable Fan Module SYN-9450). The SynQor MPS/MPPS has no other user serviceable parts inside of it. **DO NOT REMOVE** the cover of the MPS/MPPS or any of its connectors. Other than fan assembly replacement, only factory trained personnel should perform repairs.

Product Description

SynQor's Military AC-DC Power Supply Units are designed for the extreme environmental and demanding electrical conditions of Military/Aerospace applications. SynQor's MPS and MPPS incorporate field proven high efficiency designs and rugged packaging technologies. The MPS and MPPS will accept a 3-Phase input with a wide range of input voltage and frequency values while delivering a well-conditioned continuous 4000 W, fixed DC output to the load. It is designed and manufactured in SynQor's USA facilities to comply with a wide range of military standards.

A communication/control port is available to permit monitoring and control by a host computer system. Front panel LEDs provide information on the status of the MPS. For MPPS Units, the communication port allows the user to set the output voltage, and output current.

The electronic circuitry within the MPS-4000 and MPPS-4000 Series products is designed, qualified and screened according to SynQor's MIL-COTS Standards. It complies with the requirements of MIL-STD-704F, MIL-STD-1399-300B, MIL-STD-1275D, and MIL-STD-461F, as well as IEC-EN61000 specifications for world-wide commercial utility applications.

The MPS-4000 and MPPS-4000 Series products are designed and manufactured to withstand the harsh environments and use encountered in military applications. The electronic circuitry is contained in a sealed chamber constructed from a die-cast aluminum chassis that is weather-proof and shock-proof. Redundant, water-proof fans on the rear panel draw cooling air over the heat-sink fins below the sealed chamber. Military-grade circular connectors are used, and optional attached connector covers are available for when the cables are not attached. The MPS-4000 and MPP-4000 Series products comply with a wide range of testing according to MIL-STD-810G.

The SynQor MPS-4000 Series and MPPS-4000 Series products are designed and manufactured in the U.S.A.

Product Topology: MPS

The SynQor MPS-4000 Series products use an isolated topology that provides protection to the load from spikes, noise, surges, brownouts, blackouts, etc. in the input power sources. They also provide smoothing of load transients and nonlinear load profiles so that the input power source is not subjected to these disturbances.

EMI filters are present at all external inputs and outputs

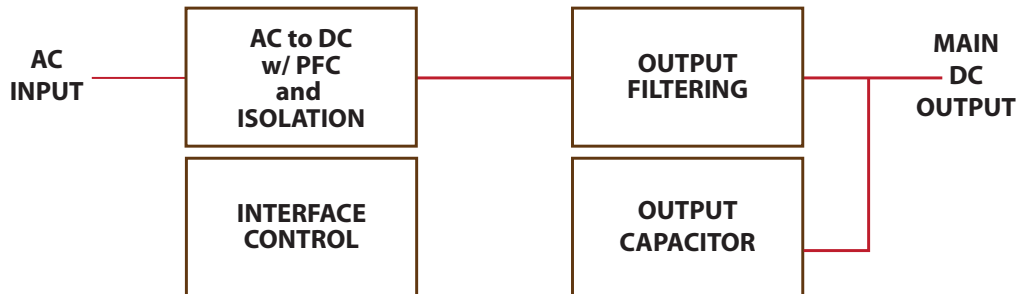

Power flows from the AC INPUT through an AC-DC converter that has Power Factor Correction (PFC) and high-frequency safety isolation.

The DC outputs at various voltage and power levels are available. The DC can deliver up to 4000 W (5250 W transient) output.

Bulk energy storage capacitors are connected to the mid-bus to help smooth imbalances in power flow between the inputs and outputs of the MPS.

There is a communication/control port that provides a digital interface to a host computer system.

Product Topology: MPPS

Similar to the MPS-4000, the MPPS-4000 Series products use an isolated topology that provides protection to the load from spikes, noise, surges, brownouts, blackouts, etc. in the input power sources. They also provide smoothing of load transients and nonlinear load profiles so that the input power source is not subjected to these disturbances. The MPPS adds an extra regulation stage to the output, which allows the user to adjust the output voltage and current.

EMI filters are present at all external inputs and outputs.

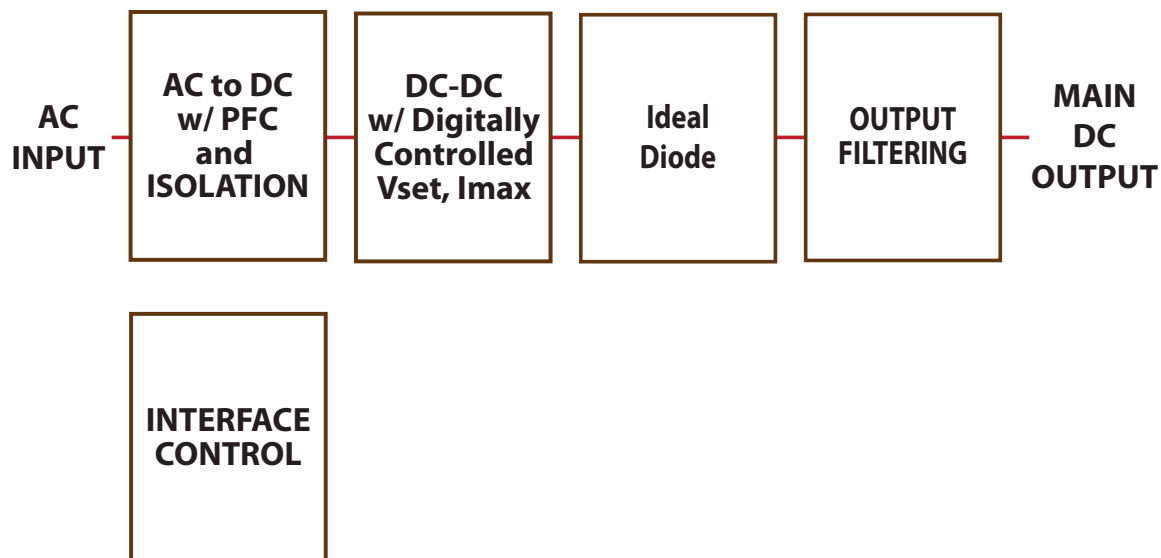

Power flows from the AC INPUT through an AC-DC converter that has Power Factor Correction (PFC) and high-frequency safety isolation.

The DC outputs at various voltage and power levels are available. The DC output voltage, and maximum output current can be programmed by the user. The DC output can deliver up to 4000 W.

Bulk energy storage capacitors are connected to the mid-bus to help smooth imbalances in power flow between the inputs and outputs of the MPPS.

An ideal diode on the output of the MPPS prevents circulating currents when Units are placed in parallel. The ideal diode also provides some degree of redundancy should one MPPS in a paralleled system experience a failure.

There is a communication/control port that provides a digital interface to a host computer system. This port is used to program the output voltage and output current.

Part Numbering Scheme and Options: MPS

This table shows the part numbering scheme for the full line of SynQor MPS products:

Base Model			
Model Number	Power	Height	Weight
MPS-4000-1U	4000 W	1U (1.73"H x 17.00"W x 20.42"D)	28 lbs.

Family	Output Power	Height	AC Input Phase #	AC Input Frequency	DC Output Voltage Range	Output Regulation	Network
MPS	4000: 4000 W	1U: 1.73"	3: 3-Phase	W: 47-800 Hz	2D: 28 V 2E: 30 V 4B: 48 V	S00: Semi-regulated	E00: Ethernet/SNMP

For valid part numbers, refer to the website or contact your local sales representative.

Part Numbering Example: MPS-4000-1U-3W2ES00-E00

The MPS-4000 Series of products provide up to 4000 W (5250 W transient) of total output power. Options that can be specified according to the part numbering scheme shown in the table include:

- The allowable frequency of the AC INPUT can be in the 47-800 Hz range.
- The nominal output voltage of the MPS-4000 Series can be 28 V, 30 V, or 48 V.
- The DC OUTPUT is semi-regulated, meaning that the voltage droops slightly as the output current increases. This facilitates current sharing when Multiple Units are connected in parallel.
- RS232 serial port and logic-level I/O communication are included in the standard model. An Ethernet port providing web and SNMP interfaces is standard.

Part Numbering Scheme and Options: MPPS

This table shows the part numbering scheme for the full line of SynQor MPS products:

Base Model							
Model Number		Power		Height		Weight	
MPPS-4000-1U		4000 W		1U (1.73"H x 17.00"W x 20.42"D)		29.5 lbs.	
Family	Output Power	Height	AC Input Phase #	AC Input Frequency	DC Output Voltage Range	Output Current Range	Network
MPPS	4000: 4000W	1U: 1.73"	3: 3 Phase	W: 47-800Hz	28: 0-35V 48: 0-54V 72: 0-80V	150: 0-150A 120: 0-120A 078: 0-78A	E00: Ethernet/SNMP

For valid part numbers, refer to the website or contact your local sales representative.

Part Numbering Example: MPPS-4000-1U-3W28-150-E00

The MPPS-4000 Series of products provide up to 4000 W of fully regulated DC output power. Various options can be specified according to the part numbering scheme shown in the table:

- The allowable frequency of the AC INPUT can be in the 47-800 Hz range.
- The default output voltage of the MPPS-4000 Series can be 28 V, 48 V, or 72 V. These models are capable of 150 A, 120 A, and 78 A maximum current respectively.
- The DC OUTPUT is fully regulated.
- When placed in parallel, Units use a communication cable to ensure they are sharing evenly. Each Unit will share to within +/- 3 A of the average current at full load. All Units must have the same output voltage programmed in order to share current evenly.
- RS232 serial port and logic-level I/O communication are included in the standard model. An Ethernet port providing web and SNMP interfaces is standard. The output voltage and current can be set via the RS-232 or web interfaces.

Product Specifications

The following three pages show the electrical and mechanical specifications of the MPS-4000-1U & MPPS-4000-1U Series of products. Data sheets showing these specifications and other information can be found at the web site <https://www.synqor.com/MPS>.

MPS-4000-1U Unit or MPPS-4000-1U Unit Front Panel



MPS-4000-1U Unit or MPPS-4000 1U Unit Rear Panel Rear Panel

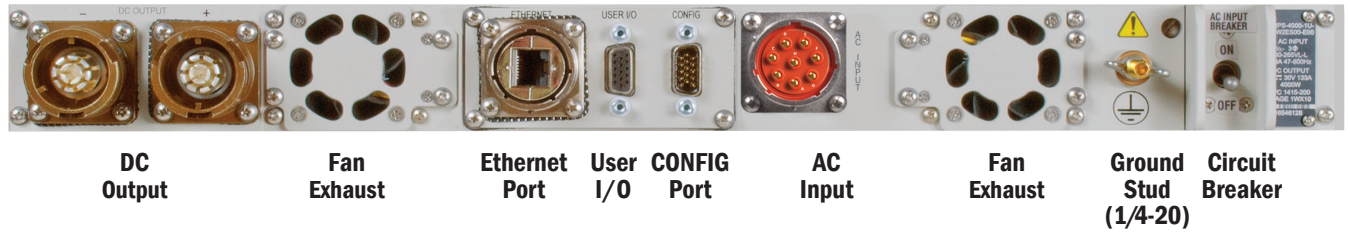

Transit Case Option

Technical Specifications: MPS

INPUT CHARACTERISTICS	
Operating AC Input	
Voltage	3-Phase, 80-265 Vrms _{L-L} *
Frequency	47-800 Hz
Input Power Factor	>0.98 at 47-65 Hz >0.97 at 400 Hz >0.92 at 800 Hz
Maximum Input Current	27 Arms May be programmed to less via communications port
AC Input Circuit Breaker Rating	30 Arms
*Power Derating vs. Vrms _{L-L} (see Figure 2 page 17)	

OUTPUT CHARACTERISTICS	
Total Output Power	
Continuous	4000 W
15 s Transient	5250 W
Nominal DC Output Voltage at No Load	
28 Vout	29.7 V
30 Vout	32.2 V
48 Vout	51.5 V
DC Output Voltage over Line, Load & Temperature	
(Semi-regulated, see Figures 3-5 page 18)	
28 Vout	30.3-27.6 V
30 Vout	32.8-29.9 V
48 Vout	52.5-47.9 V
Maximum Output Capacitance	
28 Vout	255 mF
30 Vout	222 mF
48 Vout	86.8 mF
Output Ripple Voltage (20MHz BW)	
All Output Voltages	0.5% peak-to-peak of rated Vout
Hold-up Time	
To -20% rated Vout, 4000 W	10 ms
Turn-on Delay	
All Output Voltages	2 s max.
Output Voltage Response to Load Transient	
Iout steps from 50-75% at 0.2 A/μs	3% typ. / 6% max. deviation 100 ms recovery
Over-voltage Protection	
Cyclic Restart	110-120% rated Vout
Short Circuit Protection	
Cyclic Operation	115% rated Iout

Technical Specifications: MPPS

INPUT CHARACTERISTICS		OUTPUT CHARACTERISTICS	
Operating AC Input		Total Output Power (Continuous**)	
Voltage	3-Phase, 85-265 Vrms _{L-L} *	28 V set point (MPPS-4000-3W28)	3750 W
Frequency	47-800 Hz	48 V set point (MPPS-4000-3W48)	3750 W, Vin = 115V Vrms _{L-L} 4000 W, Vin = 200 Vrms _{L-L}
Input Power Factor	>0.98 at 47-65 Hz >0.97 at 400 Hz >0.92 at 800 Hz	72 V set point (MPPS-4000-3W72)	4000 W
Maximum Input Current	27 Arms May be programmed to less via communications port	**See figures 1-3, 5,6 and the MPPS user guide for derating details	
AC Input Circuit Breaker Rating	30 Arms	Output Ripple Voltage (20MHz BW)	
		28 V set point (MPPS-4000-3W28)	150 mV pk-pk typ.
		48 V set point (MPPS-4000-3W48)	200 mV pk-pk typ.
		72 V set point (MPPS-4000-3W72)	250 mV pk-pk typ.
		Current Limit Inception	
		All Models	110%-120% Rated Current
		Hold-up Time	
		To -5% Vset, 4000 W	10 ms
		Turn-on Delay	
		All Output Voltages	2 s max.
		Output Voltage Response to Load Transient	
		Iout steps from 50-75% at 0.2 A/μs	
		28 V set point (MPPS-4000-3W28)	1 V max
		48 V set point (MPPS-4000-3W48)	1.5 V max
		72 V set point (MPPS-4000-3W72)	2 V max.
		Short Circuit Protection	
		Constant current source	110-120% Rated Current

*Power Derating vs. Vrms_{L-L} (see Figure 5)

Programmable Features: MPPS

PROGRAMMABLE FEATURES				
Model Part Number	Programmable Voltage Range	Programmable Current Range	Voltage Set Point Accuracy (Pout = 0W)	Maximum Output Current (Short Circuit)
28V Default (MPPS-4000-3W28)	0 - 35 V	0 - 150 A	±35 mV typical ±70 mV max.	180 A
48V Default (MPPS-4000-3W48)	0 - 54 V	0 - 120 A	±55 mV typical ±110 mV max.	145 A
72V Default (MPPS-4000-3W72)	0 - 80 V	0 - 78 A	±80 mV typical ±160 mV max.	95 A

Specifications subject to change without notice.

Technical Specifications: MPS & MPPS

ENVIRONMENTAL CHARACTERISTICS MIL-STD-810G	
Temperature Methods 501.5, 502.5	
Operating Temperature	
Full Rated Power	-40 °C — +55 °C
Reduced Power per Figure 6	-40 °C — +70 °C
Storage Temperature	-40 °C — +70 °C
Altitude Method 500.5	
Operating	0 - 18,000 ft
Non-operating	0 - 40,000 ft
Environmental Tests	
Shock/Drop	Method 516.6, Procedures 1,4,6
Temperature Shock	Method 503.5, Procedure 1
Vibration	Method 514.6, CAT 5, 7, 8, 9, 24
Fungus	Method 508.6
Salt Fog	Method 509.5
Sand and Dust	Method 510.5, Procedures 1,2
Rain	Method 506.5 Procedure 1
Humidity	Method 507.5 Procedure 2
Mechanical Vibrations of Shipboard Equipment	Method 528 Procedure 1

RELIABILITY CHARACTERISTICS MIL-HDBK-217F		
MTBF	240 kHrs	MIL-217F Ground Benign, Ta=25 °C

ELECTROMAGNETIC CAPABILITY MIL-STD-461F (At 50/60Hz)	
CE101	30 Hz - 10 kHz
CE102	10 kHz - 10 MHz
CS101	30 Hz - 150 kHz
CS106	10 kHz - 40 GHz
CS114	10 kHz - 200 MHz
CS116	10 kHz - 100 MHz
RE101	30 Hz - 100 kHz
RE102	10 kHz - 18 GHz
RS101	30 Hz - 100 kHz
RS103	2 MHz - 40 GHz

MECHANICAL CHARACTERISTICS	
Standard 1U Chassis	
Chassis Size	1.73"(1U)H x 17.00"W x 20.42"D
Case Material	Aluminum
MPS Total Weight	28 lbs
MPPS Total Weight	29.5 lbs
Connectors	
AC Input Connector	MS3470L18-8PW
DC Output Connector (+)	CGE2E18H5FB-16
DC Output Connector (-)	CGE2E18H5FWB-16
User I/O Ports	HD DB15 Female
Configuration I/O Port	HD DB15 Male
Ethernet Port	Amphenol RJF22N00, Code B
Cooling Exhaust Fans	
Sound Pressure Level (SPL)	54 dB(A)
Air Flow	0.67(m3/min) 23.7 CFM

Two fans in system, above specs are for each fan separately.

1U Mechanical Diagram

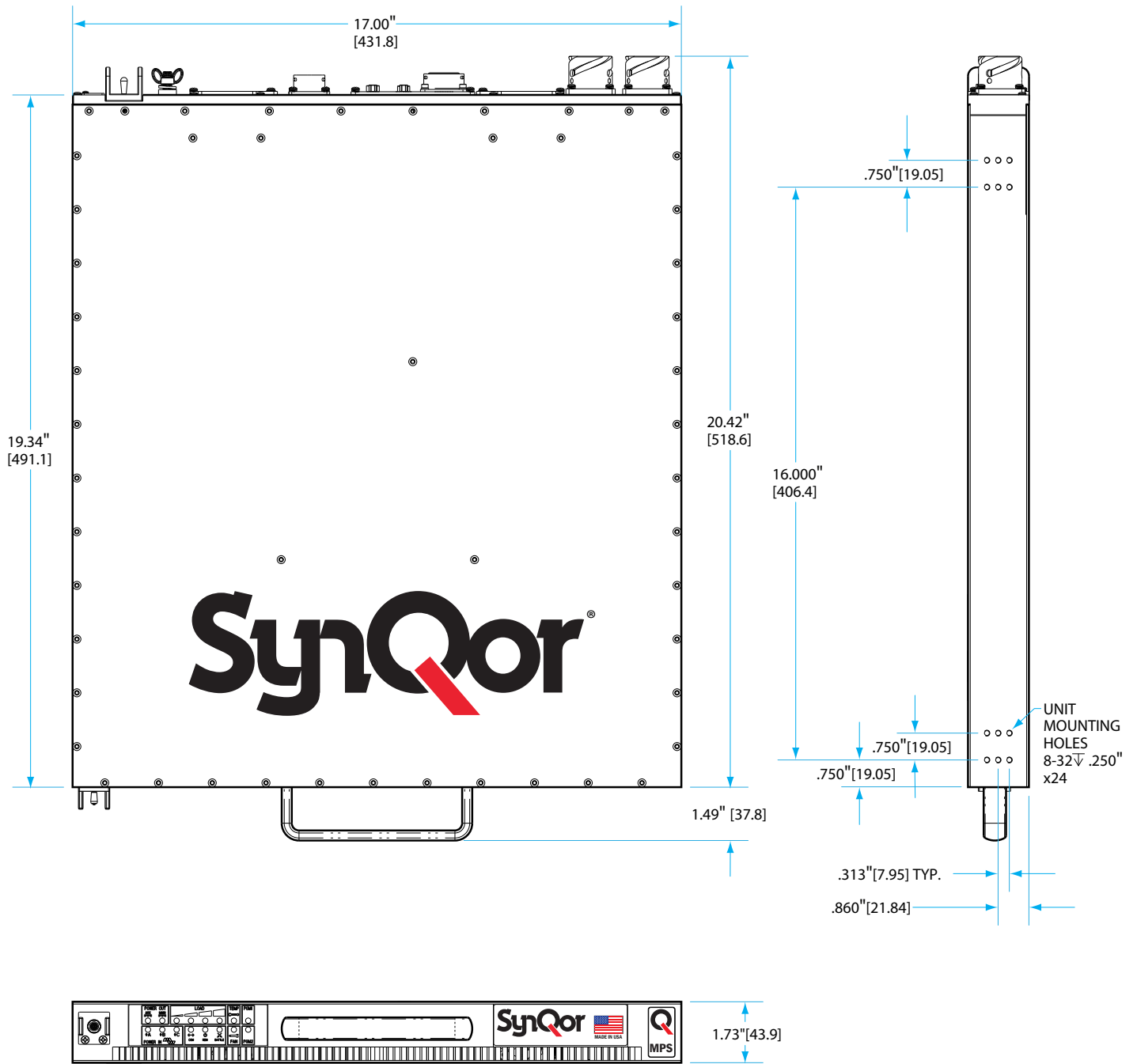

Efficiency: MPS

Figure 1 shows the typical efficiency with which the MPS-4000 series power supplies delivers power to its DC OUTPUT from a 208 V_{rms}_{L-L} AC INPUT and an 115 V_{rms}_{L-L} AC INPUT:

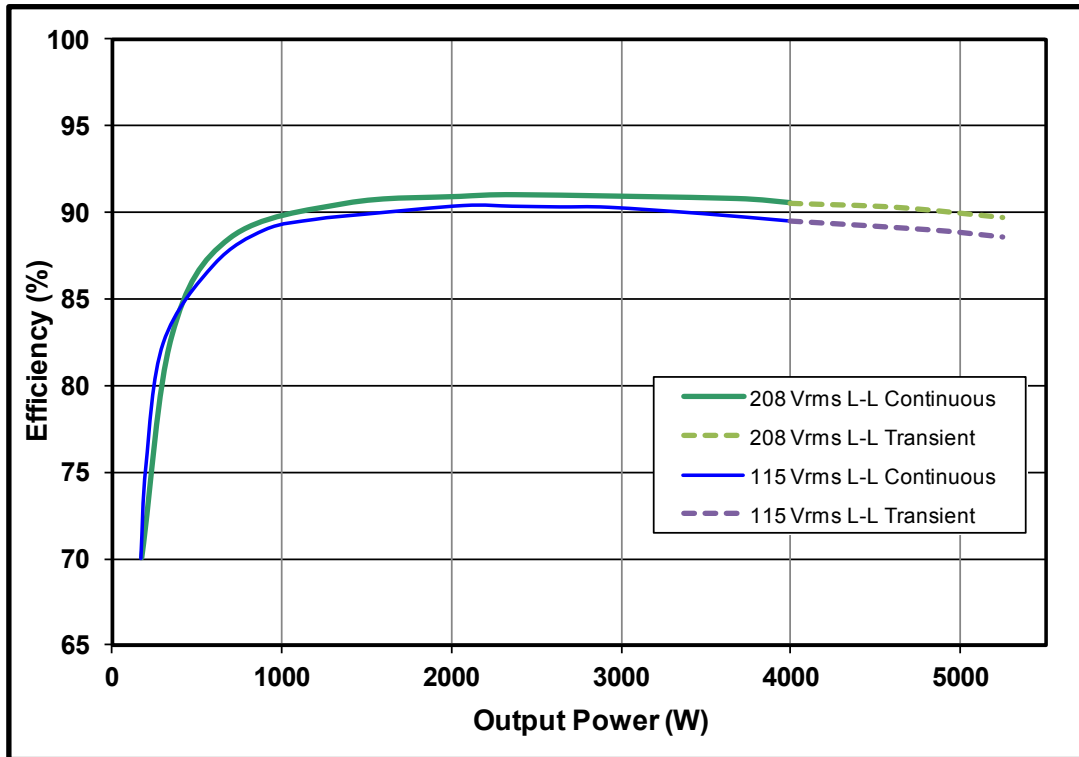

Figure 1

Total Output Power: MPS

The total MPS output power for the MPS-4000 series is rated at 4000 W (5250 W TRANSIENT) for an ambient temperature as high as 55°C (131°F).

However, when the AC INPUT voltage is at the low end of its range (<100 V_{rmsL-L}) or between its low and high range (140 V_{rmsL-L} - 160 V_{rmsL-L}) the MPS will not be able to deliver its full rated output power in both the steady-state and transient situations. Figure 2 indicates the total steady-state and transient output power that the MPS can deliver under these conditions.

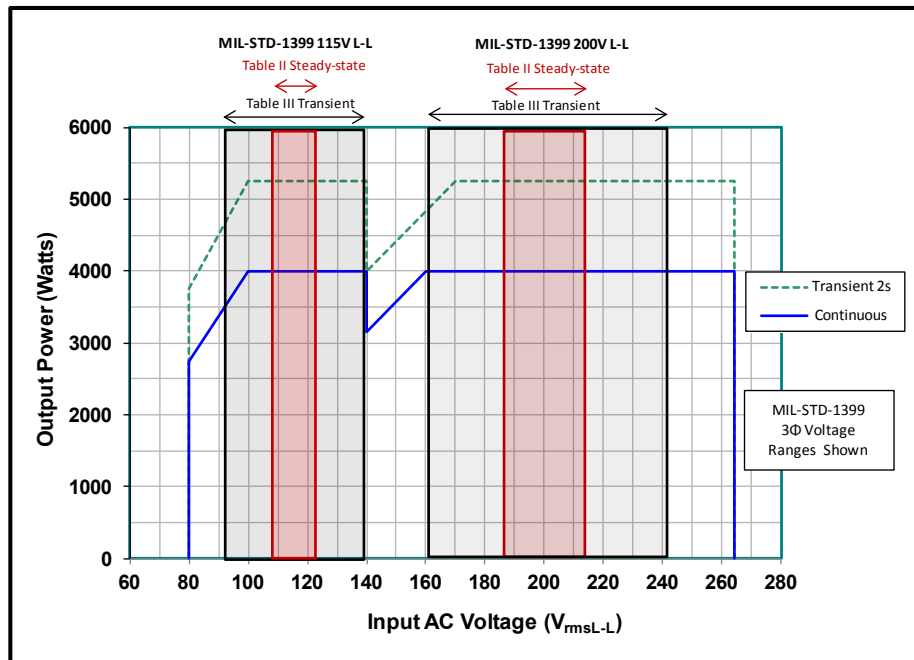

Figure 2

Temperature Derating: MPS

The maximum steady-state MPS output power as a function of ambient air temperature and AC input voltage is shown below in Figure 3.

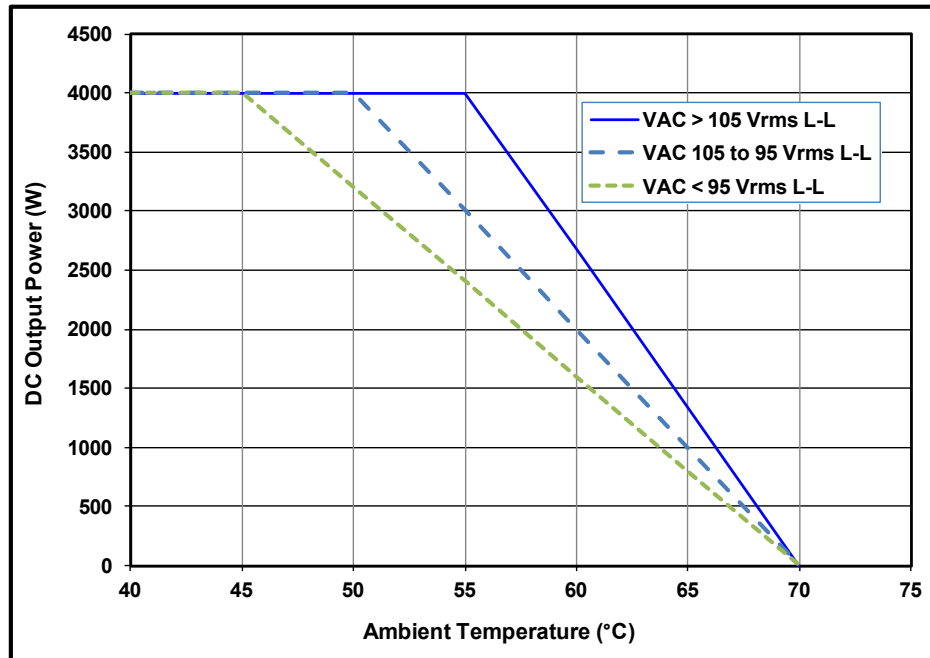

Figure 3: Output Power vs. Ambient Temperature

Efficiency: MPPS

Figure 4 shows the typical efficiency with which the MPPS-4000 series power supplies delivers power to its DC OUTPUT from a 200 V_{rms}_{L-L} AC INPUT and an 115 V_{rms}_{L-L} AC INPUT. The extra regulation stage of the MPPS causes the efficiency to be slightly lower when compared to an MPS. Also note that there is no transient rating for the MPPS.

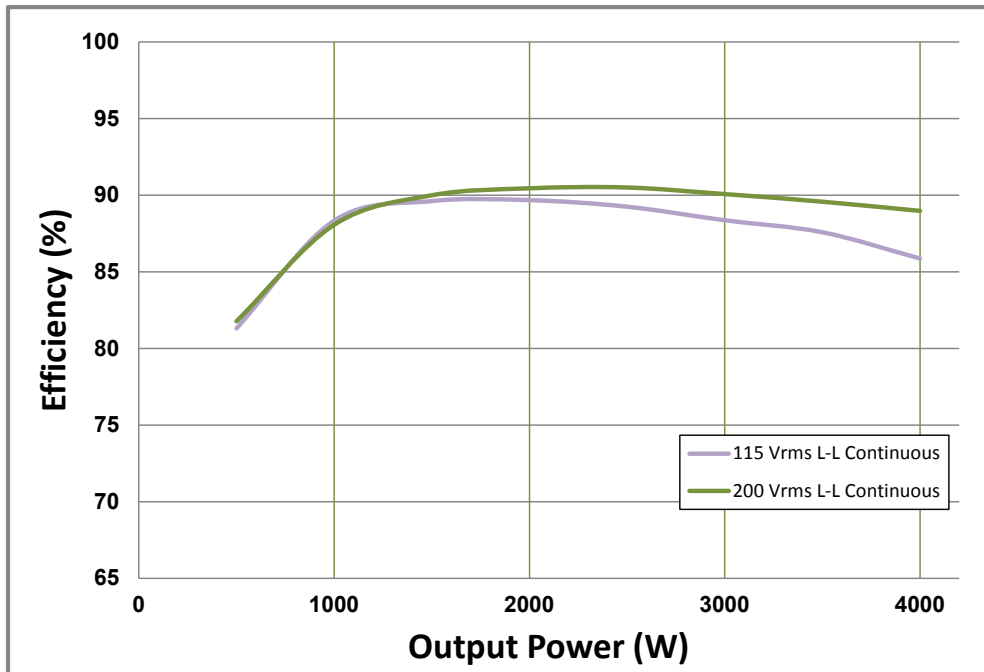

Figure 4: Efficiency vs Output Power

Output Power Derating: MPPS

The MPPS derating procedure is as follows:

1. Determine the available power from the Vout derating curve
2. Determine the available power from the Vin derating curve
3. *The minimum of these two curves is the available power*
4. Determine the derated power from the thermal derating curve (Figure 9). Note that the available power from step 3 will not need to be derated further if the temperature is below 55°C.

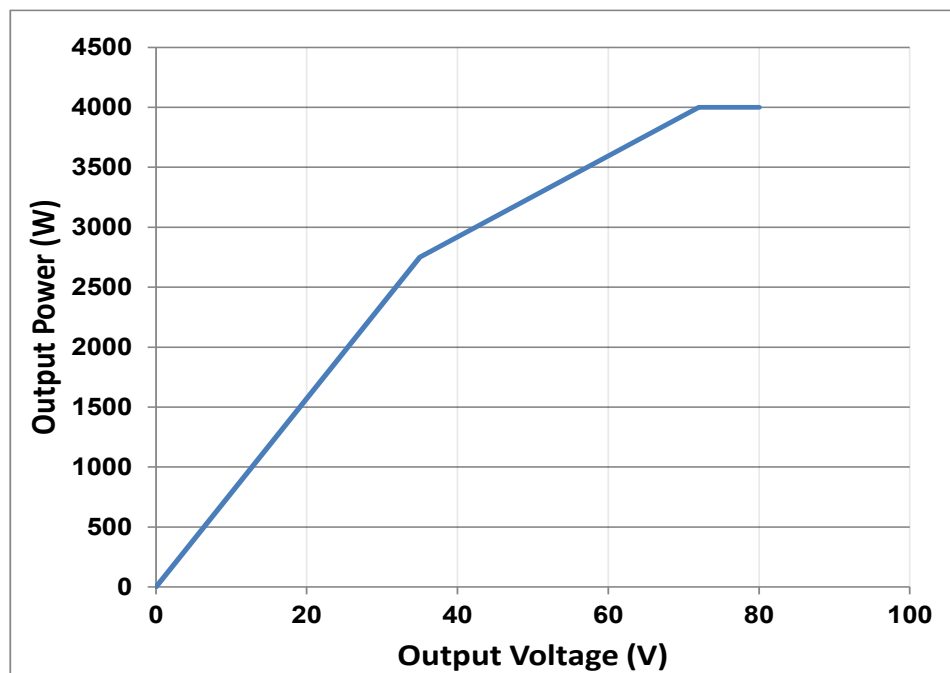

Figure 5: Vout derating. 72V model Available Output power vs Output voltage

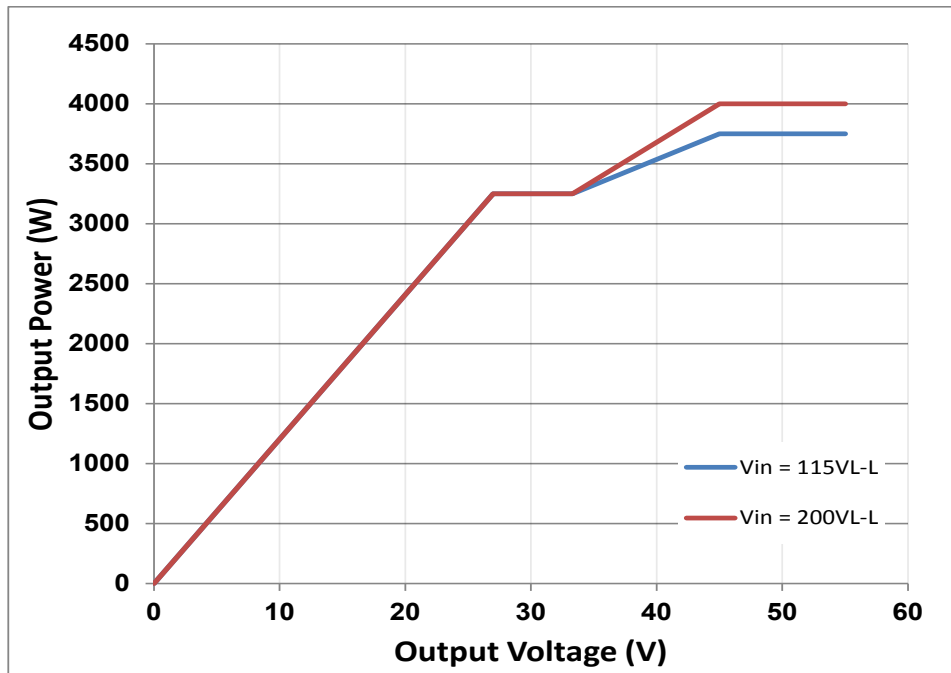

Figure 6: Vout derating. 48V model Available Output power vs Output voltage

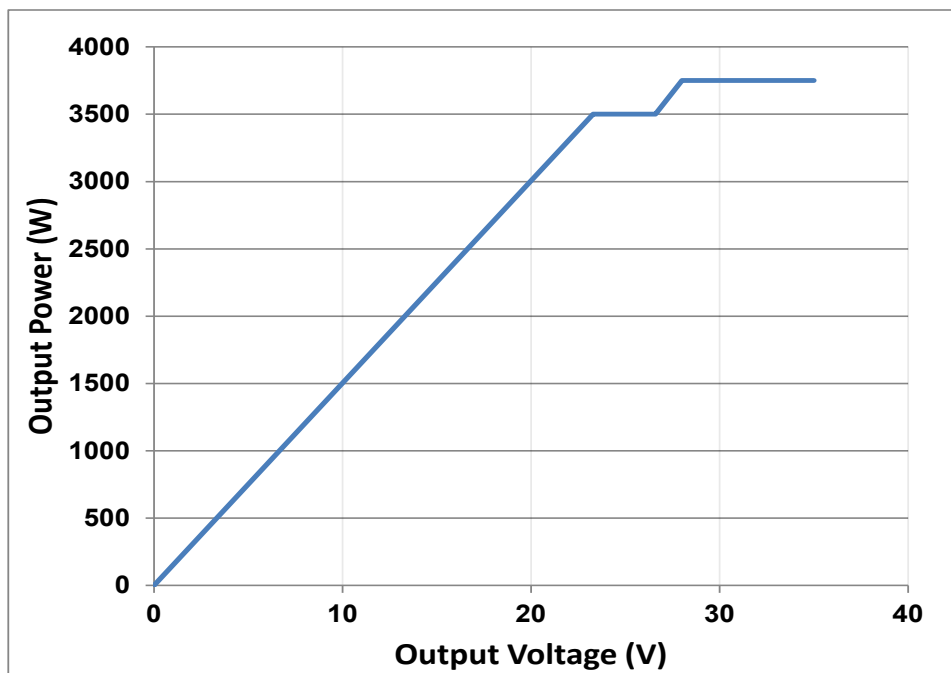

Figure 7: Vout derating. 28V model Available Output power vs Output voltage

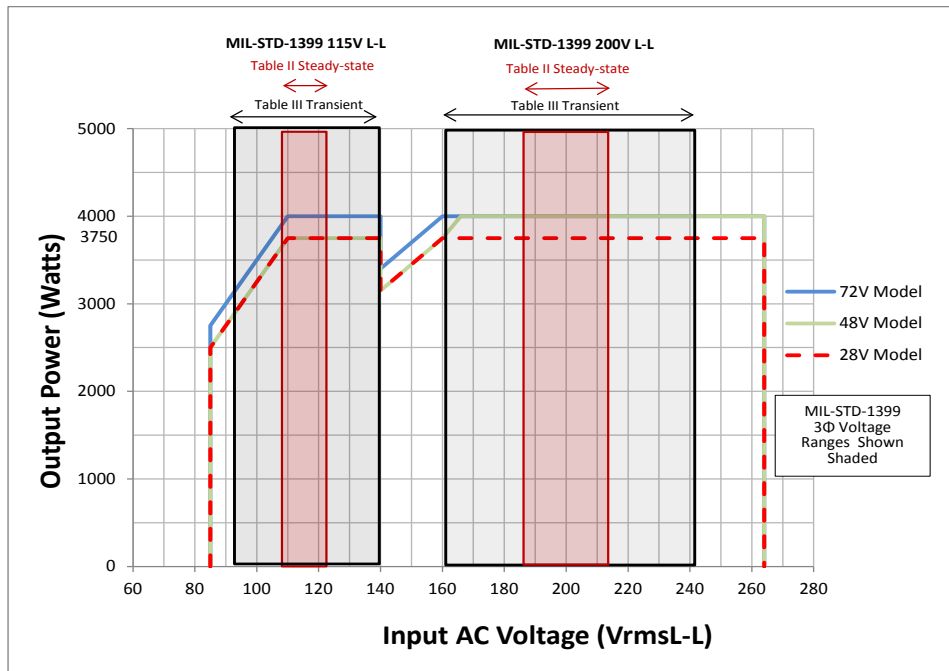

Figure 8: Vin derating. Available Output power vs input Ac voltage

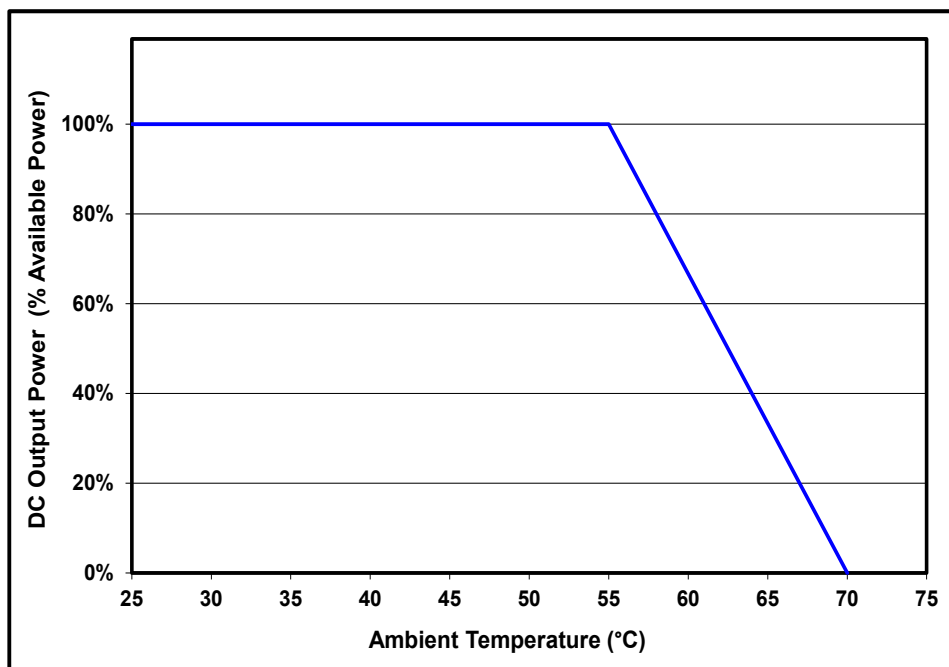

Figure 9: Thermal derating. Output Power vs Ambient temperature

Total Output Power: MPPS

The total MPPS output power for the MPPS-4000 series is at most 4000 W for an ambient temperature as high as 55°C (131°F). The 72 V model is rated for 4000 W at 115 V_{rmsL-L} and 200 V_{rmsL-L}. The 48 V model is rated for 3750 W at 115 V_{rmsL-L} and 4000 W at 200 V_{rmsL-L}. The 28V model is rated for 3750 W at 115 V_{rmsL-L} and 200 V_{rmsL-L}.

However, when the AC INPUT voltage is at the low end of its range (<110 V_{rmsL-L}) or between its low and high range (140 V_{rmsL-L} – 166 V_{rmsL-L}) the MPPS will not be able to deliver its full rated output power. The figure below indicates the total steady-state output power that the MPPS can deliver under these conditions.

Unlike the MPS, the MPPS does not have a transient power rating. Exceeding 4000 W under any condition will cause the output voltage to fold back.

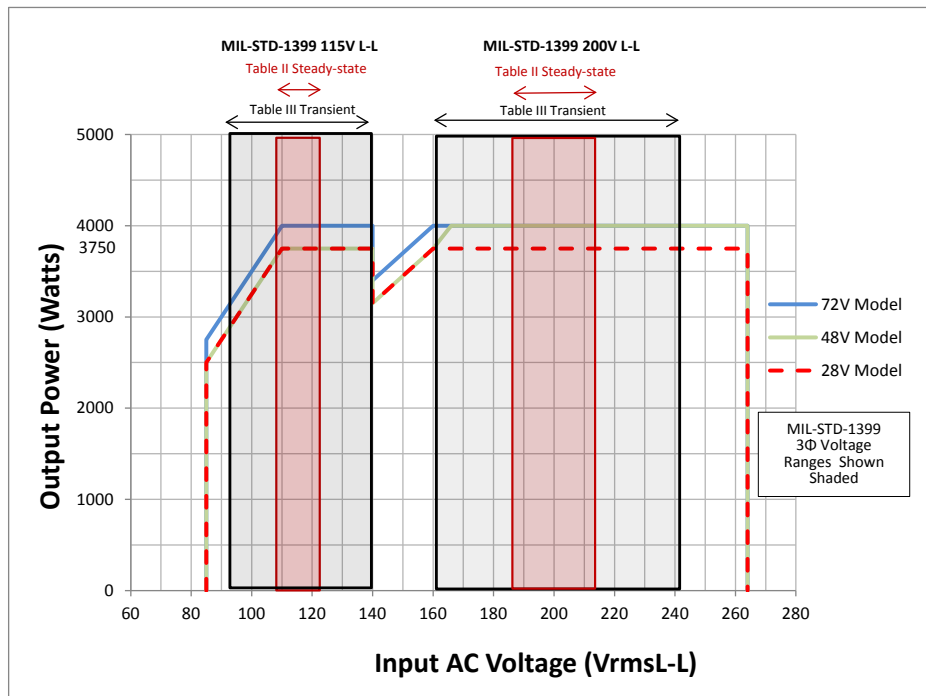

Figure 10 – Vin Derating. Available Output Power vs AC input voltage

MPS Droop Characteristics - All Output Voltages

The MPS output voltage is semi-regulated. As the output current increases, the output voltage will decrease. Typically, the output voltage will decrease by 10% at full load.

Note that the full rated output power of 4000 W can be derived from the AC INPUT having a voltage within this uncommon range for up to 15 seconds before the MPS will shutdown its output. Also note that the MPS can drive at full rated power for a 2 second interval even if the AC INPUT voltage drops below 100 V_{rms,L-L}.

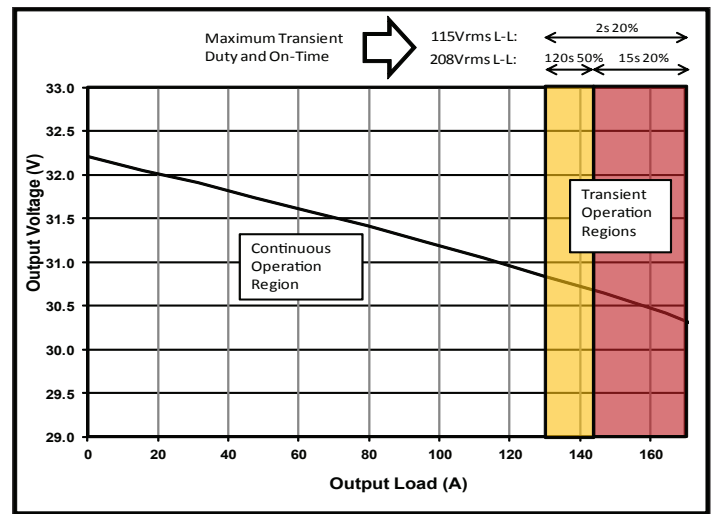
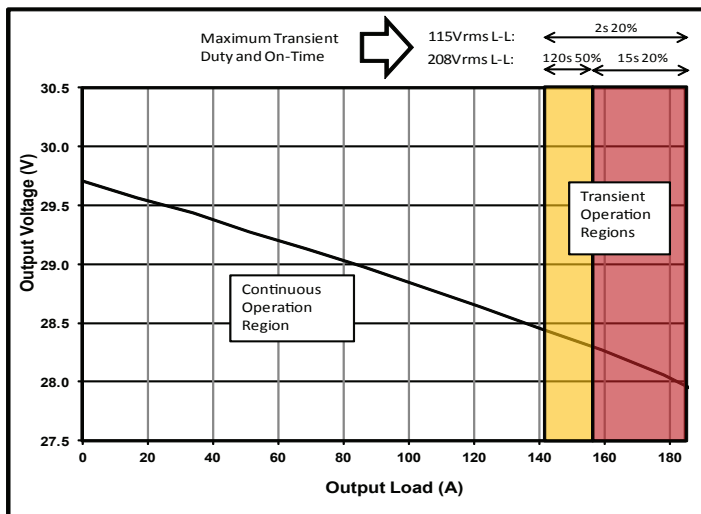

Figure 11: 28Vout Droop Characteristics

Figure 12: 30Vout Droop Characteristics

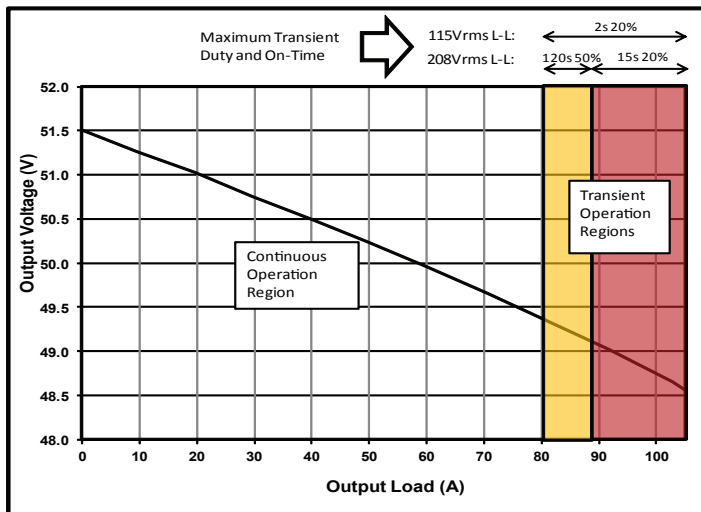

Figure 13: 48Vout Droop Characteristics

MPPS Overload Characteristics

Unlike the MPS which has a semi-regulated output voltage, the MPPS output voltage is fully regulated.

The output voltage is determined by the user programmed value of V_{set} , and the maximum output current is determined by the user programmed value of I_{max} . Note that I_{max} is 115% of the rated output current. In the figure below, the axis values of V_{out} and I_{out} are % V_{set} and % I_{rated} respectively. This shows that the MPPS will be able to maintain the programmed output voltage as long as the output current is less than 110% of the rated output current. If I_{out} exceeds 110% of I_{rated} , the output voltage will be reduced according to the figure below. This is referred to as “Voltage Foldback”.

As an example, consider a MPPS with $V_{set} = 30\text{ V}$, $I_{max} = 50\text{ A}$. The MPPS calculates I_{rated} from I_{max} , 43.5 A in this case. The MPPS will hold V_{out} at 30 V as long as I_{out} is less than 47.8 A (110% of I_{rated}). Between 47.8 A and 50 A, the MPPS will reduce the output voltage to 0 V. While at 0 V the MPPS will limit the output current to I_{max} , in this case 50 A. The output voltage will return to 30 V once the load has been reduced below 47.8 A.

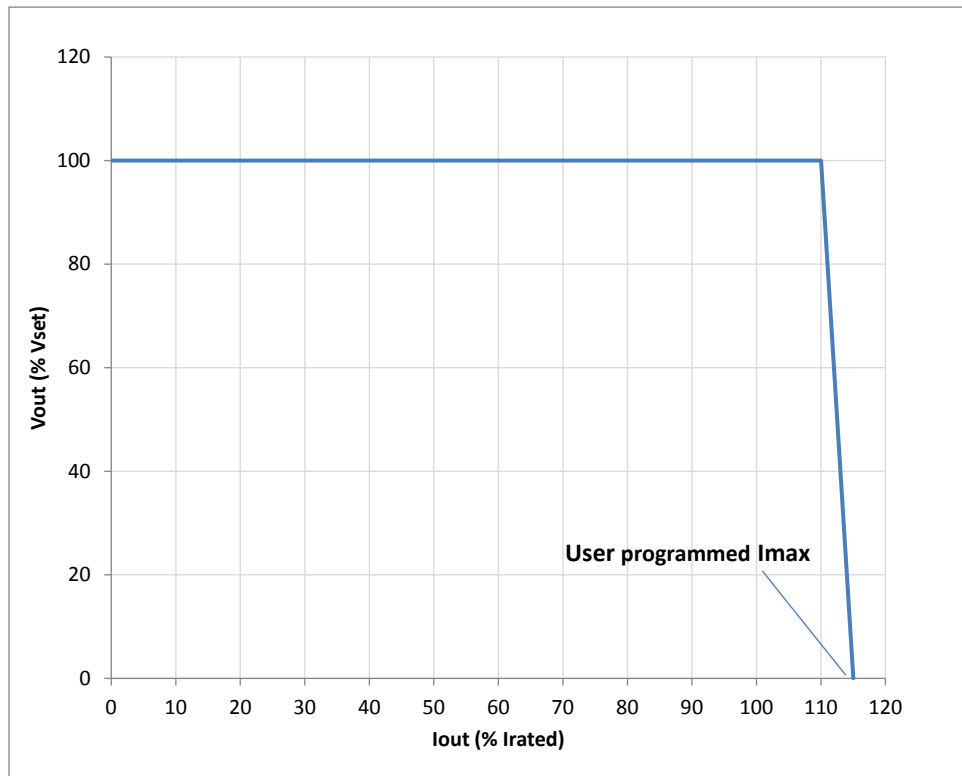
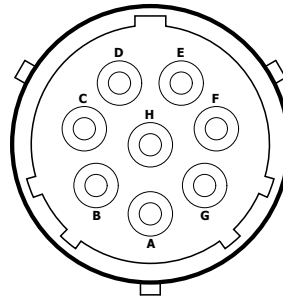

Figure 14: Voltage Fold Back During Current Limit, Short Circuit

Power Cable Wiring Diagram

Looking at the rear panel, the MPS and MPPS connector terminals have the following functions and locations:

AC INPUT	
Pin	Function
A, B	Line 1
C, D	Line 2
E, F	Line 3
G, H	Ground



DC OUTPUT	
Key	Function
A	-V

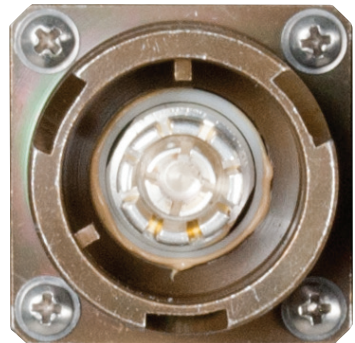
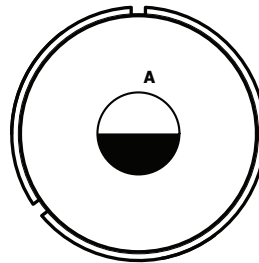

DC OUTPUT	
Key	Function
B	+V

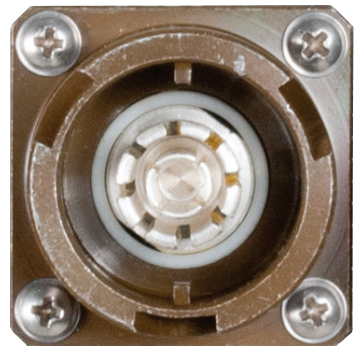
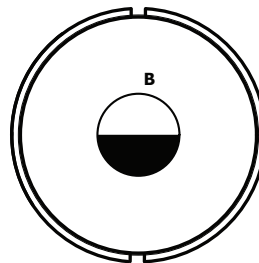

Set-Up

The recommended procedure for setting up the MPS or MPPS is the following:

- Make sure the AC BREAKER on the rear panel of the MPS or MPPS is in the OFF position.
- The AC breaker on the rear panel is classified as a supplementary protector and is not designed for branch circuit protection. A suitable circuit breaker should be added externally for the AC input if branch circuit protection is required.
- Connect the ground wire to the ground stud on the rear panel of the MPS or MPPS.
- Connect the DC OUTPUT cables, first to the MPS or MPPS and then to the load with the correct polarity.
- Connect the USER I/O cables.
- Connect the INPUT cables, first to the MPS or MPPS and then to the AC source.
- Turn on the source (if they have an up stream breaker).
- Move the AC BREAKER on the rear panel of the MPS or MPPS to the ON position.

Start-Up

- VERIFY that all connections to the MPS or MPPS are correct.
- If the AC source is present and within specifications, the three POWER IN LEDs on the front panel will be green.
- Momentarily push the ON/OFF switch on the front panel of the MPS or MPPS upward. The switch can then be released and it will return to its normal (neutral) position.

Shut-Down

- Shut down the equipment connected to the MPS or MPPS.
- Push the ON/OFF switch on the front panel of the MPS or MPPS downward and hold it in this position for 1 second (or more). The switch can then be released to return to its normal position.
- The MPS or MPPS will disable its outputs.
- It is not necessary to move the AC BREAKER on the rear panel of the MPS or MPPS to the OFF position.

Power Cable Connections

For safety reasons, the input and output power cables should be connected to the MPS or MPPS before the source of AC power is turned on, and before the MPS or MPPS is turned on (see **Section I: Warnings** and the **SET-UP** section above). Similarly, one should first turn off the MPS or MPPS and the source of input power before any power cables are disconnected from the MPS or MPPS .

ALSO NOTE that when the MPS or MPPS is turned on and delivering power to a load, and then another piece of equipment is connected to the same output, it is possible that this connection will momentarily disrupt the quality of the MPS or MPPS's output voltage.

Programming The Output: MPPS Only

For the MPPS, the output voltage and output current can be programmed using the RS-232 interface or using the web page interface. The MPPS cannot be programmed using the SNMP interface.

Programming the Output From the Web Interface

- Ensure the web interface is configured properly. See the Ethernet-SNMP user guide for details: http://www.synqor.com/mps/documents/MPS_Ethernet_SNMP_UG.pdf
- Navigate to the “control” tab. The default address is <http://169.254.1.1/control.htm>
- In the “Configuration” section, enter the desired output voltage in mV click UPDATE. For example “30000” corresponds to 30.000 V output.
- In the “Configuration” section, enter the desired output current in amps click UPDATE. For example, “50” corresponds to 50 A.

Configuration

Configuration settings are stored in non-volatile memory and will persist after power-down.

<input type="text" value="30000"/>	Set nominal voltage for main MPPS Output.
<input type="button" value="UPDATE"/>	
<input type="text" value="50"/>	Set nominal output current limit for main MPPS Output.
<input type="button" value="UPDATE"/>	

Programming the Output From the RS-232 Interface

- Ensure RS-232 interface is configured properly. RS-232 must be configured with 115.2kbaud, 8 data bits, no parity, and one stop bit.
- Output voltage and current can be set with “SET VOUT x” and “SET IMAX” commands. “SET VOUT x” will set the output voltage level in millivolts. “SET IMAX x” will set the maximum current level in amps. See the “MPS User Commands” document for details: https://www.synqor.com/MPS/documents/MPS_User_Commands.pdf
- In the example below, “SET VOUT 30000” sets the output voltage to 30.000 V. “SET IMAX 50” sets the maximum current to 50 A

```
SYNQOR>SET VOUT 30000  
DAC SET. FLASH UPDATED.
```

```
SYNQOR>SET IMAX 50  
DAC SET. FLASH UPDATED.
```

Cooling System

The SynQor MPS-4000 & MPPS-4000 Series products are cooled by fans that draw air into the intake on the front panel and exhaust it out the two fan ports on the rear panel. Care should be taken to ensure there is no obstruction to this airflow, either at the front intake or the rear exhaust ports. Similarly, care should be taken to avoid obstructing the fan blades.

The speed of the cooling fans is automatically controlled to provide adequate MPS or MPPS cooling while extending the life of the fan bearings. Under low ambient temperature and/or low MPS or MPPS output power the fans will be driven at a low speed. If the ambient temperature and output power are such that the MPS or MPPS cannot otherwise maintain its specified maximum temperature for its internal circuitry, the fans will momentarily be driven at a speed that exceeds their rated long-term running speed.

If the ambient temperature is low enough (for the level of power being delivered to the load), the fans may not be on. This is not a malfunction. It is done to preserve the life of the fans. If the fans are off, check the Fan Service Required LED on the front panel. If it is GREEN, the fans are functioning properly and simply not needed under the present conditions.

The fans are weather-proof and water-proof.

The MPS or MPPS has two fans to provide redundancy for these exposed, moving components. With only a single operating fan the MPS or MPPS is still able to deliver 80% rated power at an ambient temperature of 40°C, and it is able to deliver 60% of its rated power at an ambient temperature as high as 55°C.

Front Panel Indicators

To indicate the status of the MPS or MPPS there are 16 LEDs on the front panel. These indicators are described in this section.



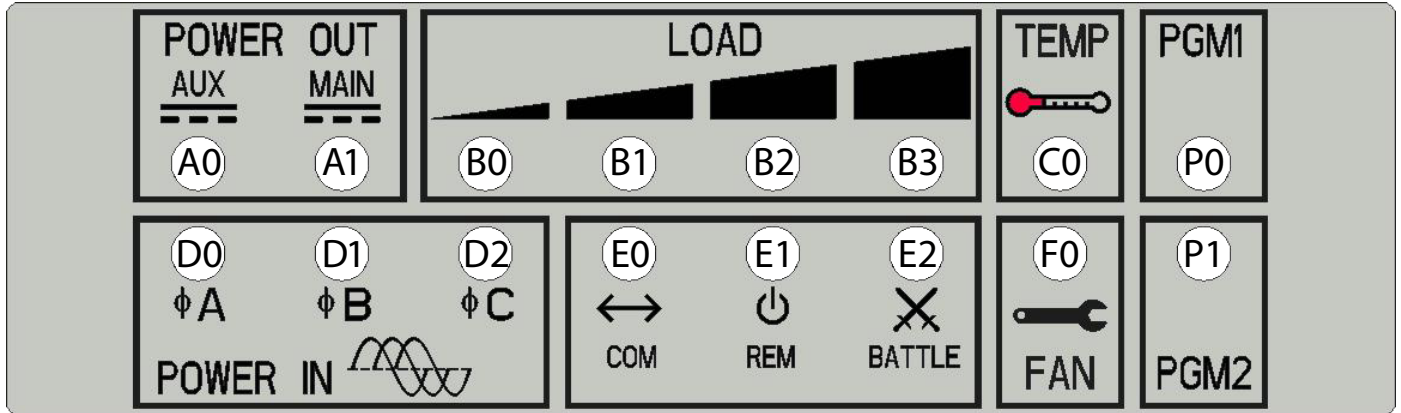

LEDs

Each Unit has 16 LEDs, as shown below, that indicate the status of the operation of the Unit:







- Power-In Indicators (LEDs in positions D0, D1 and D2)**

The LEDs D0, D1, and D2 indicate the status of input phases A, B and C: Status is monitored on a line to line basis:

LED Appearance	Description	Indication
	Green	<i>Input is Ready to Provide Load Power</i>
	Amber	<i>Input is Not within Range</i>
	Red	<i>Input is Not Present</i>
	Off	<i>Unit is Off</i>





- Power-Out Indicators (LEDs in positions A0 and A1)**

The LED in position A0 indicates the status of the Auxiliary DC OUTPUT and the LED in position A1 indicates the status of the Main DC OUTPUT, according to the table below:

LED Appearance	Description	Indication
	Green	<i>Unit is On and the Output Voltage is Within Range</i>
	Amber	<i>Unit is On but the Output Voltage is Out of Range</i>
	Red	<i>Unit is Off and the Output Voltage is Within Range</i>
	Off	<i>Unit is Off (Or the Auxiliary DC Output Option is not Installed)</i>





• **Load Power Indicators (LEDs in positions B0 – B3)**

The LEDs in positions B0 through B3 indicate the total output power of the Unit according to the table:

LED Appearance	Description	Indication
	<i>B0 Dimmed Green; B1-B3 Off</i>	<i>Total Load Power <25%</i>
	<i>B0 Green; B1 Dimmed Green; B2-B3 Off</i>	<i>Total Load Power <50%</i>
	<i>B0, B1 Green; B2 Dimmed Green; B3 Off</i>	<i>Total Load Power <75%</i>
	<i>B0, B1, B2 Green; B3 Dimmed Green</i>	<i>Total Load Power <100%</i>
	<i>B0; B1; B2 Green; B3 Blinking Red</i>	<i>Total Load Power ≥100%</i>



• **MPS or MPPS Cooling System Indicator (LED in position C0)**

The LED in position C0 indicates the temperature and status of the cooling system for the Unit according to the table below:

LED Appearance	Description	Indication
	Green	<i>Moderate Temperature (Fans Running at 33%)</i>
	Blinking Green	<i>Warm Temperature (Fans Running at 67%)</i>
	Amber	<i>Elevated Temperature (Fans Running at 100%)</i>
	Red	<i>Maximum Temperature (Fans Running at 110%)</i>



• **Fan Service Required Indicator (LED in position F0)**

The LED in position F0 indicates whether the two cooling fans in the rear panel of the Unit are OK or if their performance is degraded, according to the table below:

LED Appearance	Description	Indication
	Green	<i>Both Fans are OK</i>
	Amber	<i>One or Both Fans Have Recently Had Degraded Performance and Diagnostic Tests are Being Performed</i>
	Red	<i>One or Both Fans Presently Have Degraded Performance</i>

• **Control Status (LED in position E0, E1, E2)**

The LED in position E0, E1 or E2 indicates whether RS232 or Ethernet Port, Remote Enable/Shutdown or Battle Short are active:

LED Appearance	Description	Indication
	Green	<i>E0: RS232 active or Ethernet Port Active, E1: Remote Enable Active</i>
	Blinking Red	<i>E2: Battle Short Mode Active, Temperature Shutdowns Removed</i>
	Red	<i>E1: Remote Shutdown Active</i>

• **Reserved (LED in position P0 & P1)**

This section of the LED panel has been reserved for future use.

Operating Environment

The SynQor MPS-4000 and MPPS-4000 Series is designed for the extreme environmental conditions of military and aerospace applications. All the electronic circuitry is contained in a sealed, weather-proof, shock-proof chamber constructed of die-cast aluminum. Only the redundant, water-proof cooling fans are exposed to the environment. The Unit will shut down if it is too hot and Battle Mode is not active.

The MPS and MPPS (with cables connected or connector covers installed) has been qualified to the following requirements of MIL-STD-810G:

MIL-STD-810G Test Method	Name	Procedure	Details
500.5	Low Pressure	I, II and III	<ul style="list-style-type: none"> ▪ 18,000 ft. operating ▪ 40,000 ft. storage
501.5	High Temperature	I and II	<ul style="list-style-type: none"> ▪ +55°C operating ▪ +65°C storage
502.5	Low Temperature	I and II	<ul style="list-style-type: none"> ▪ -20°C operating ▪ -20°C storage
503.5	Temperature Shock	I	<ul style="list-style-type: none"> ▪ 10 cycles; >10°C/minute
506.5	Rain	I	<ul style="list-style-type: none"> ▪ 4" rain/hour ▪ 40 mph wind velocity
507.5	Humidity	NA	<ul style="list-style-type: none"> ▪ >95%
508.6	Fungus	NA	<ul style="list-style-type: none"> ▪ 28 day test
509.5	Salt Fog	NA	<ul style="list-style-type: none"> ▪ 5% salt solution ▪ 2 cycles (24 hr wet/24 hr dry)
510.5	Sand and Dust	I and II	<ul style="list-style-type: none"> ▪ 20 mph blowing dust ▪ 40 mph blowing sand
514.6	Vibration	Category 5	<ul style="list-style-type: none"> ▪ 5 Hz (300 RPM) ▪ Loose Cargo
514.6	Vibration	Category 7	<ul style="list-style-type: none"> ▪ General Exposure
514.6	Vibration	Category 8	<ul style="list-style-type: none"> ▪ C-130 Aircraft level
514.6	Vibration	Category 9	<ul style="list-style-type: none"> ▪ General Exposure
514.6	Vibration	Category 24	<ul style="list-style-type: none"> ▪ PSD = 0.04 g²/Hz; 20-2000 Hz ▪ Operating
516.6	Shock	I, IV and VI	<ul style="list-style-type: none"> ▪ 20 g/20 ms; 40 g/11 ms; 75 g/6 ms ▪ 48 inch drop in transit case ▪ 30 degree tilt and drop
528	Mechanical Vibrations of Shipboard Equipment	I	<ul style="list-style-type: none"> ▪ Operating

Control Cable Connections

There are two high-density (three-row) DB15 connectors located on the rear panel of the MPS or MPPS:

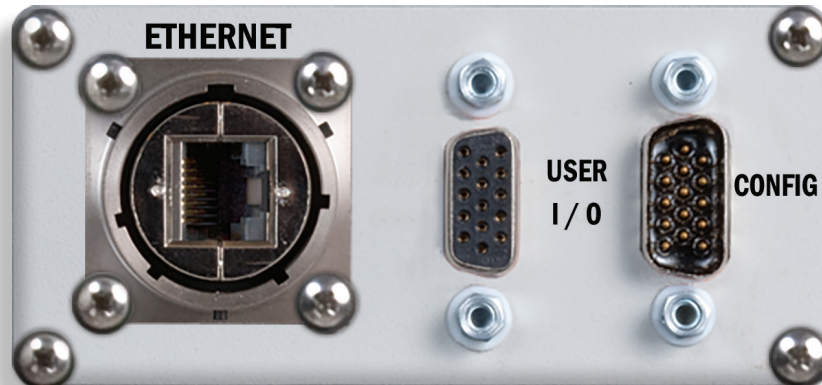

The User I/O female DB15 connector on the left is for an optional connection to a host/system computer so that it can control the MPS or MPPS and receive information regarding the status of the MPS or MPPS.

The Configuration male DB15 connector on the right provides for synchronized startup and shutdown operation of Multiple Interconnected Units, using the configuration cables. For MPPS Units, the Configuration connector also provides active current sharing. See description “Synchronized Operation of Multiple Units” on page 41.

The designation/location of the pins for the User I/O female high-density DB15 connector is shown below:

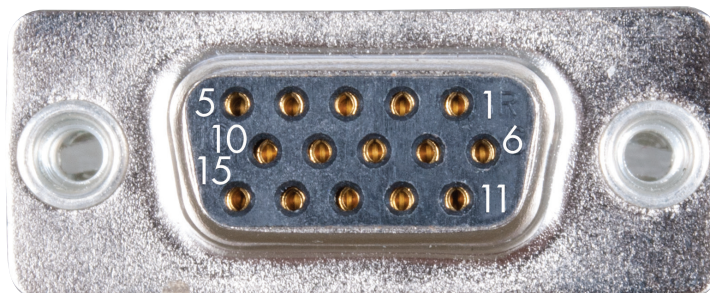

Internal User I/O Circuits

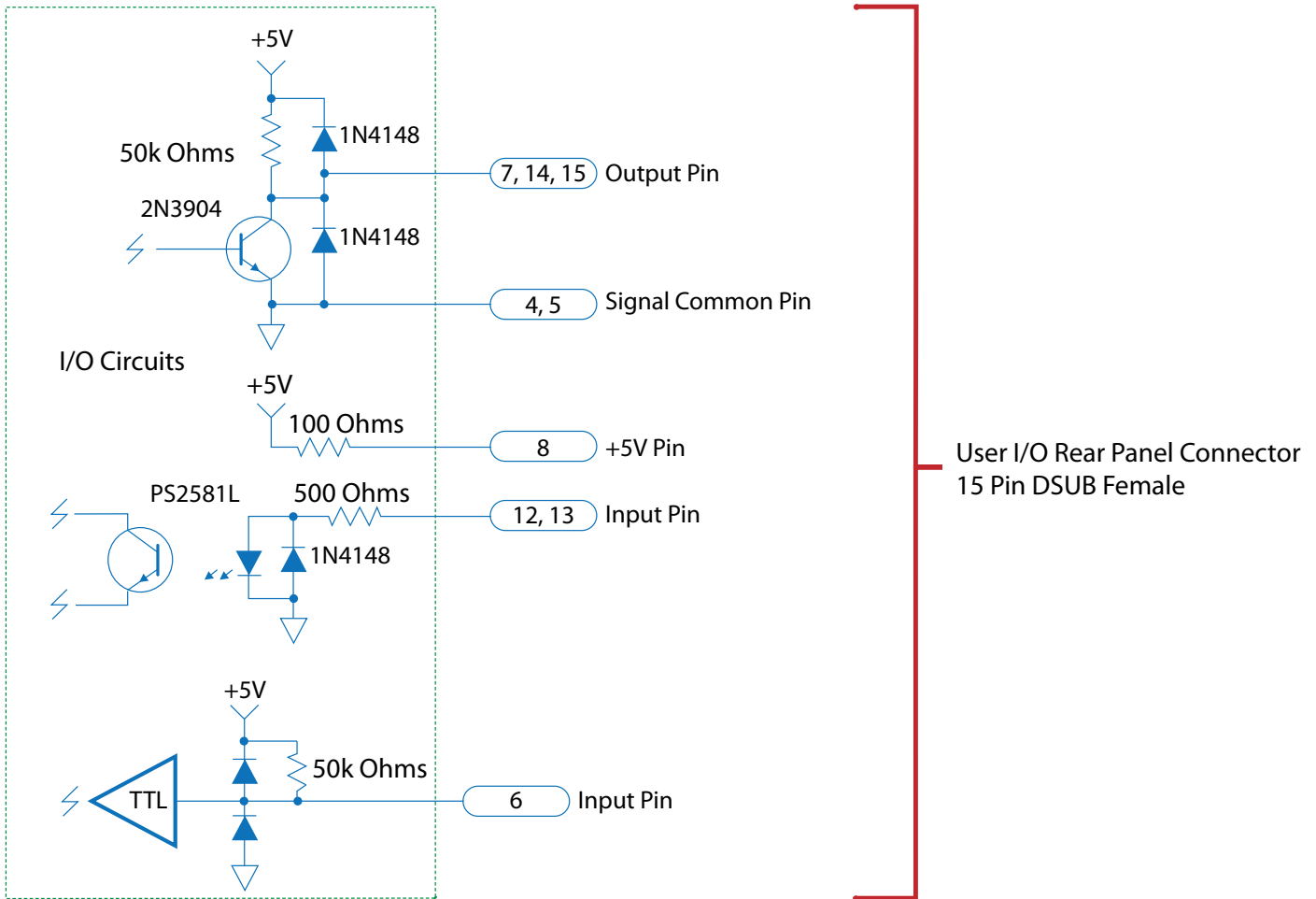

Remote On/Off Switch Connections

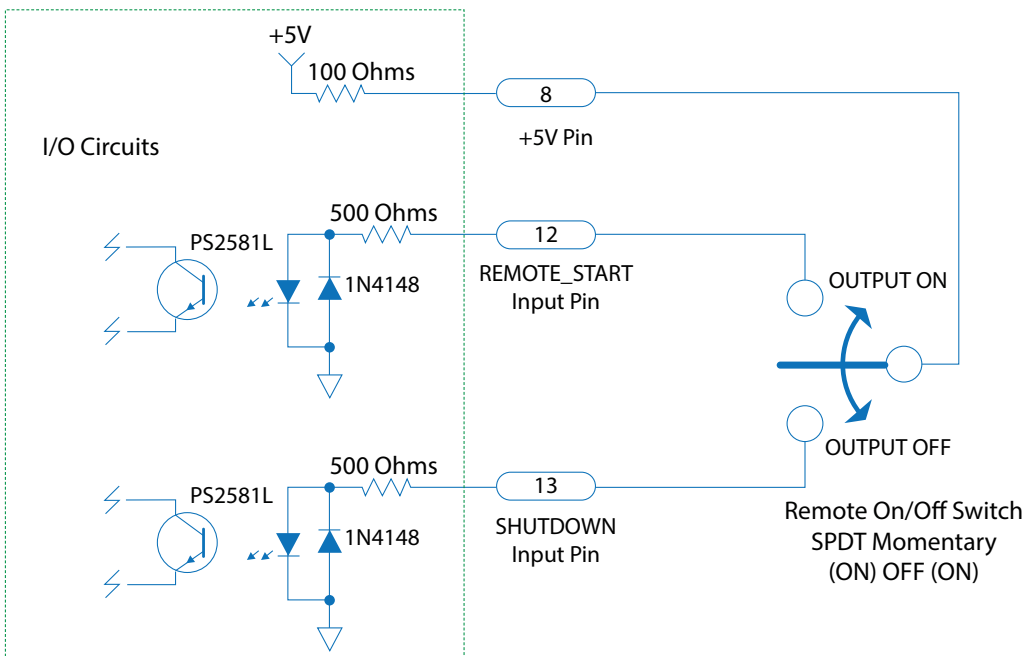

Note: A 2PDT or 3PDT switch may be substituted for single control of 2 or 3 MPS or MPPS machines, respectively.

Digital Input/Output Control Signals

There are 3 input and 4 output digital signals available on the User I/O female high-density DB15 connector. The pin assignments and functions of these digital I/O signals are as follows:

High Density DB15 Female (15 Pin Connector)

Signal	PIN	Function
TX	2	RS232 DCE Device Transmit
RX	3	RS232 DCE Device Receive
GND	4, 5	Ground reference for all digital inputs and outputs
BATTLE_MODE	6	TTL-Input*, pull "low" to engage Battle Mode (disable internal over-temperature protection), has internal pull-up to +5 V.
ACIN_GOOD	7	Open collector* output where "low" indicates AC Input voltage is within range
+5 V	8	Vout with minimal current drive usable as a pull-up voltage for open collector output signals. Load must be <35 mA
REMOTE_START	12	Drive this line "high" with ≥ 5 mA to enable MPS/MPPS outputs
SHUTDOWN	13	Drive this line "high" with ≥ 5 mA to disable MPS/MPPS outputs
OUT_OK	14	Open collector* output where "low" indicates Main DC Output voltage is within range
OVER_TEMP	15	Open collector* output where "low" indicates that the MPS/MPPS is at or above its maximum temperature

*With an internal 50 k Pull-up Resistor to 5 V and ESD Protection Diodes.

Battle Mode disables internal over-temperature shutdown limits in the MPS or MPPS hardware. Battle Mode is indicated with a flashing red light in panel position E2. This mode can be commanded by pulling low on to I/O Port Pin 6, or via serial command *BS ON*.

RS232 Serial Interface

The same User I/O female high-density DB15 connector also provides for an RS232 interface between the MPS /MPPS and the host/system computer. The interface has a 115.2 k baud with eight data bits, no parity bit and one stop bit. The pin assignments and functions for this RS232 interface are as follows:

Signal	Pin Number	Function
GND	4 and 5	Ground reference for RX and TX signals
RX	3	RS232 DCE/MPS or MPPS Device Receive signal
TX	2	RS232 DCE/MPS or MPPS Device Transmit signal

The RS232 port provides readback of Units's state, as well as the configuration and control of the MPS/MPPS's operation. The port can be used from a standard terminal interface, or from a custom computer application. For MPPS Units, this port can be used to program the output voltage, and the output current.

Readback information that is available:

- Programmed Vset (MPPS only)
- Programmed I_{max} (MPPS only)
- Battle Mode
- Fan diagnostics
- Fault Shutdown Synchronization Control
- On/Off Synchronization
- Output enable / disable

Parameters that are controllable through the interface:

- Vset (MPPS only)
- I_{max} (MPPS only)
- AC Input Voltage
- AC Input Current
- AC Input Frequency
- DC Output Power
- External Switch Input Status
- Fan RPM
- Internal Temperatures
- Total Output Power

For a detailed description of the terminal interface see the SynQor website at:

https://www.SynQor.com/MPS/documents/MPS_User_Commands.pdf

Ethernet Interface

The optional Ethernet interface provides a web page based user interface for monitoring and control of the MPS. For MPPS Units, the user can set the output voltage and output current with the Ethernet interface. The interface also exposes an SNMP interface compliant to RFC-1628.

The Ethernet interface supports 10BASE-T and 100BASE-T standards. It utilizes a standard RJ-45 connector, also allowing a metallic sealable circular military outer housing. The interface supports auto-negotiation, polarity correction, and Auto-MDIX (detection and use of straight through or cross-over cables).

IP address assignment can be done via DHCP or user entry of a static address. The interface also supports a direct connection between the MPS/MPPS and a host computer by including a DHCP server internal to the MPS/MPPS.

For a detailed description of the Ethernet port and SNMP implementation see the SynQor website at: https://www.synqor.com/MPS/documents/MPS_Ethernet_SNMP_UG.pdf

Synchronized Operation of Multiple Units: MPS

Interconnecting Multiple Units via the Configuration port enables synchronized start-up, shutdown, restart, and fault behavior of connected Units.

Turn-On, Turn-Off, Restart Control:

When an MPS device is in the Standby Mode (input power applied but output not enabled), and its output is enabled via the front panel switch, remote enable input, or serial command, all other MPS devices that are also in the Standby Mode will enable their outputs at the same time. Likewise, when a Unit is operating and its output is running, if its output is disabled via the front panel switch, remote shutdown input, or serial command, all other MPS devices that are also operating will disable their outputs at the same time. Finally, when an MPS restarts after a fault event, it will coordinate its restart to be simultaneous with other MPS devices restarting during the same interval. These features are enabled by default when the a configuration cable is utilized to interconnect multiple MPS devices. The features can be disabled via the serial interface using the SYNCCON OFF command, and this setting is stored in non-volatile memory. These features can also be disabled via the web interface. See Table 1 for a list of configuration cables.

Fault Synchronization Control:

When an MPS device is operating, and the output shuts down due to a load fault, such as a short circuit, the Fault Synchronization Control will cause other MPS devices interconnected via the configuration cable to shutdown at the same time. This feature is disabled by default. It can be enabled via the serial interface by issuing the command, and the setting is stored in non-volatile memory. The feature can also be enabled via the web interface.

Four Units	SYN-9344
Three Units	SYN-9343
Two Units	SYN-9341

Table 1: List of Configuration Cables

Parallel Operation of Multiple Units: MPPS

Interconnecting Multiple Units via the Configuration port enables synchronized start-up, shutdown, and current sharing of connected Units.

Turn-On, Turn-Off, Restart Control:

When an MPPS device is in the Standby Mode (input power applied but output not enabled), and its output is enabled via the front panel switch, remote enable input, or serial command, all other MPPS devices that are also in the Standby Mode will enable their outputs at the same time. Likewise, when a Unit is operating and its output is running, if its output is disabled via the front panel switch, remote shutdown input, or serial command, all other MPPS devices that are also operating will disable their outputs at the same time. These features are enabled by default when the SYN-9341 or SYN-9343 cable is utilized to interconnect multiple MPPS devices. The features can be disabled via the serial interface using the SYNCCON OFF command, and this setting is stored in non-volatile memory. These features can also be disabled via the web interface.

Parallel Operation, Current sharing:

When Parallel operation has the following requirements and characteristics:

- Configuration cables must be used to parallel multiple units. See Table 1 for details.
- All MPPS Units must have the same programmed Vset value.
- MPPS Units will share to ± 3 A of the average output current at full load.
- Ideal diode on the output of the MPPS prevents circulating currents.

When MPPS Units are placed in parallel, a digital current sharing algorithm adjusts the output voltage of each MPPS slightly to ensure each Unit is delivering approximately the same amount of current. If the MPPS Units have different programmed values for Vset, the current share algorithm will not run. This will not cause damage to the MPPS Units, however it is very likely they will not share current evenly. Output cables should be constructed so the output resistance is approximately equal for each MPPS Unit.

Fans

The fans on the rear panel have sealed bearings that do not require any regular maintenance. Fan assemblies are user replaceable with kits available from SynQor. Please contact the SynQor factory for obtaining fan replacement kits.

Cleaning

The MPS/MPPS Unit has a sealed chamber for its electronics that is weather-proof. Only the fans on the rear panel are exposed to the environment, and these fans are also weather-proof. The Unit can therefore be cleaned without concern of getting liquids inside the chamber. **NOTE**, however, that if the cables have been removed from the connectors the connectors should have their covers installed. If they are not, then care should be taken to not get excess liquid on the connector terminals. **ALSO NOTE** that care should be taken to not get excess liquid on the switch of the AC BREAKER on the back panel.

Cleaning should be done either with soap and water or with an Isopropyl alcohol and water mixture. A soft cloth should be used.

Do not immerse the Unit in water to clean it.

Fault Conditions

The SynQor MPS/MPPS has no user-serviceable parts within it other than the cooling fans. If it has an internal malfunction only factory trained personnel should attempt to repair it.

There are, however, several external conditions that could cause the MPS/MPPS to not operate as desired. These external conditions can likely be corrected by the user.

The 16 LEDs on the front panel are the best and first place to look to determine what might be wrong with the Unit. The table on the next several pages is therefore organized by what these LEDs indicate, and for each indication there is a listing of what might possibly be wrong.

The front panel LED array is shown below. The designations of the 16 LEDs in this array are used in the following table.

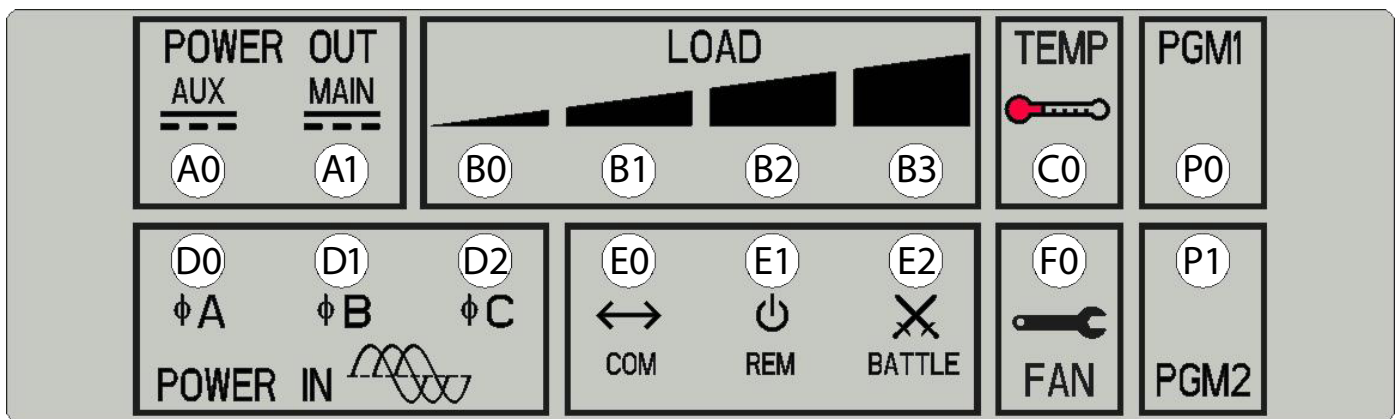

LED	Indication	Possible Problem(s)
D0, D1, D2: AC INPUT Power LED	LED is OFF	<ul style="list-style-type: none"> •The AC INPUT power source is not turned on. •The AC INPUT cable is not connected or it is wired wrong. •The AC Breaker on the rear panel is OFF. •The MPS/MPPS Unit is OFF and needs to be turned ON.
	LED is AMBER	<ul style="list-style-type: none"> •The AC INPUT voltage is either too low or too high.
	LED is RED	<ul style="list-style-type: none"> •The AC INPUT voltage is missing at least one phase on its source.
A0, A1: DC OUTPUT Power LED	LED is OFF	<ul style="list-style-type: none"> •The optional auxillary DC OUTPUT is not available on the Unit. (A0) •The Unit is OFF and needs to be turned ON.
	LED is AMBER	<ul style="list-style-type: none"> •The DC OUTPUT load is too high. •The DC OUTPUT is shorted within the cable or a load. •Some other source of power is connected to the DC OUTPUT.
	LED is RED	<ul style="list-style-type: none"> •The Unit has been turned OFF, but due to a malfunction within the Unit it is still running and providing an DC OUTPUT voltage. •Some other source of voltage is connected to the DC OUTPUT and is powering it when the Unit is disabled.

LED	Indication	Possible Problem(s)
B0 – B3: LOAD POWER LEDs	B3 is BLINKING RED	<ul style="list-style-type: none"> •Total load power is greater than or approaching 4000 W. The Unit may still be delivering its specified output voltage because the load power is not high enough to trigger the power limit circuitry.
	B0 – B3 are all OFF	<ul style="list-style-type: none"> •No power is being delivered to the load. •The Unit is OFF and needs to be turned ON. •The loads or output cables are not connected. •The loads are all turned off. •The loads are simply not drawing any appreciable power at the time.
C0: Cooling System LED	LED is BLINKING GREEN	<ul style="list-style-type: none"> •Indicates that the fans are running at 67% of their rated speed. There is no problem.
	LED is AMBER	<ul style="list-style-type: none"> •Indicates that the fans are running at 100% of their rated speed. There is no problem, but the Unit is operating at a high ambient temperature and a high load combination.
	LED is RED	<ul style="list-style-type: none"> •Fans are running at 110% of rated speed to keep the Unit cool. The maximum recommended temperature may be exceeded, but the fans are keeping things cool enough to avoid triggering the over-temperature shut-down circuitry.
F0: Fan Service Required LED	LED is AMBER	<ul style="list-style-type: none"> •One or both fans have recently had degraded performance but seem to be ok now. The Unit is running a diagnostic test.
	LED is RED	<ul style="list-style-type: none"> •One or both fans presently have degraded performance, even if they are running, and service is recommended at the earliest convenient time. •Ensure that the fan blades are not obstructed from turning
All LEDs:	All LEDs are OFF	<ul style="list-style-type: none"> •The Unit is OFF and needs to be turned ON. •The AC INPUT power is not turned ON. •The AC Breaker on the rear panel is OFF.

Three other conditions should be mentioned:**• The fans are off when the MPS/MPPS Unit is running**

It is normal for the fans to be off, even if the Unit is running and delivering power to the load, as long as the temperature of the Unit is low enough. If the Fan Service Required LED (F0) is green, both of the fans are OK, even if they are not running.

• The MPS/MPPS Unit does not turn off when the ON/OFF switch is pushed down

When the ON/OFF switch on the front panel is pushed down, the Unit does not respond to this signal for approximately 1 second. This is done to ensure that the Unit is not accidentally turned off. If the user does not hold the ON/OFF switch in the OFF position for a full second before releasing it, the Unit will not turn off.

• MPPS Units do not share current evenly

MPPS Units must have the exact same programmed output voltage in order to share properly. The active current sharing algorithm will not attempt to share with Units that have a different programmed output voltage.

Consider two Units in parallel. If one is set to 28000 mV and the other is set to 28001 mV, the active current sharing algorithm will not run.

Other possible situations that are the result of external issues that a user could likely correct are related to:**• Loads that draw a large surge of current at start-up**

Some loads draw a very large amount of current when an input voltage is first applied to them. This might happen when the Unit is first turned on if the load is already connected to the Unit. Or it may happen when the load itself is turned on and/or connected to the DC OUTPUT of a Unit that is already running. Common examples of such loads are motors and incandescent lights, but some electronic equipment can also display this characteristic.

Several problems could arise with such a load:

- A newly started load disturbs the existing Unit loads.

If this disruption of existing loads is a problem, then the solution is to make sure the loads that display this start-up surge characteristic are all started first, or that all loads are started at the same time.

NOTES

MPS MILITARY FIELD-GRADE

MILITARY POWER SUPPLY

Operator's Guide MPS-4000 Series & MPPS-4000 Series



Made in USA

006-0006715

11/10/2025

REV N

SynQor
Advancing The Power Curve®