

MPC MILITARY FIELD-GRADE

MILITARY POWER CONDITIONER

Operator's Guide MPC-1250 DC Output Series



MPC-1250-1S

SHALLOW RACK MOUNT!

SynQor
Advancing The Power Curve®

Table of Contents

SECTION I

WARNINGS

<i>Hazardous Voltages</i>	4
<i>Hazardous Energies</i>	5
<i>Protection from the Environment</i>	5
<i>User Serviceable Parts</i>	5

SECTION II

GENERAL PRODUCT INFORMATION

<i>Product Description</i>	6
<i>Product Topology</i>	7
<i>Part Numbering Scheme and Options</i>	8
<i>Electrical Characteristics</i>	9
<i>Product Specifications</i>	10
<i>MPC-1250-1S 1U Mechanical Diagram</i>	11
<i>MPC Efficiency</i>	12
<i>Total Output Power that can be derived from the AC INPUT</i>	13
<i>Power Cable Wiring Diagram</i>	15
<i>Power Cable Wire Size</i>	16

SECTION III

OPERATION

<i>Set-Up</i>	18
<i>Start-Up</i>	19
<i>Shut-Down</i>	19
<i>Power Cable Connections/Disconnections While Operating</i>	20
<i>Cooling System</i>	21
<i>Front Panel Indicators</i>	22
<i>LEDs</i>	22
<i>Audible alarm</i>	25
<i>Operating Environment</i>	26

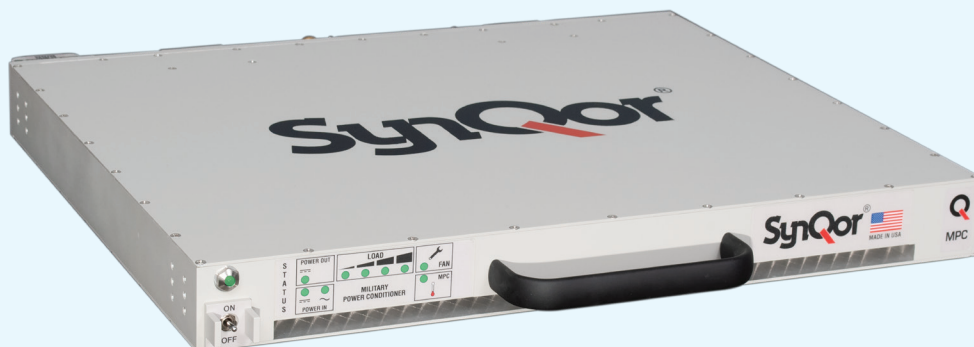

SECTION IV

CONSTANT CURRENT MODEL

<i>Overview</i>	27
<i>User Settable Parameters – CCCV charging</i>	27
<i>Setting CCCV parameters</i>	28
<i>Over Power and Over Current Protection</i>	29
<i>Entering and Exiting Charge Mode</i>	30
<i>Visual indicators - External Battery Charge Level</i>	30
<i>Output Vampire Current – Unpowered</i>	31
<i>Reverse Polarity Protection</i>	31

SECTION V

MULTIPLE MPC CONFIGURATIONS

<i>Parallel Connection of DC OUTPUTS – Parallel Option</i>	32
<i>N+M Redundancy - Ideal Diode</i>	32
<i>Configuration Cables</i>	33
<i>On/Off control – Parallel Systems</i>	33

SECTION VI

CONTROL INTERFACE DETAILS

<i>Control Cable Connections</i>	34
<i>Internal User I/O Circuits</i>	35
<i>Remote On/Off Switch Connections</i>	35
<i>Digital Input/Output Control Signals</i>	36
<i>RS232 Serial Interface</i>	36
<i>Ethernet Interface</i>	37

SECTION VII

MAINTENANCE

<i>Fans</i>	38
<i>Cleaning</i>	38

SECTION VIII

TROUBLE-SHOOTING GUIDE

<i>Fault Conditions</i>	39
-------------------------------	----

Hazardous Voltages

The **INPUT AND OUTPUT POWER** connectors and cables of the SynQor MPC may have voltages that are unsafe. **INJURY OR DEATH ON CONTACT** may result. Appropriate safety precautions should be taken. All connections should be made in accordance with **LOCAL ELECTRICAL CODES**.

- The MPC **CHASSIS** should be connected to earth or system ground with Ground Stud on the rear panel, see mechanical diagrams.
- For the **AC INPUT** cable and connector:
 - Do not assume that a hazardous voltage is not present at the terminals of the AC input connector, even if the MPC appears to be off.
 - Do not make contact with the terminals of the AC input connector.
 - Always connect the cable to the MPC before it is connected to the source of AC power.
 - Always disconnect the AC input cable from the source of AC power before disconnecting it from the MPC.
 - If the AC input cable is connected to the source of AC power and not connected to the MPC, do not contact the exposed terminals of the AC input cable.
 - Do not assume that the source of AC power is not present.
 - Connections between the AC input cable and the source of AC power should not be accessible.
- For the **DC INPUT** cable and connector:
 - The rated DC input voltage of the MPC is below the level considered hazardous.
 - The DC input terminals of the MPC are isolated from the AC input with reinforced safety insulation.
 - However, never assume the terminals of the DC input connector or the wires of the DC input cable are safe to contact, *even if the MPC or DC input source appears to be off*.
- For the **DC OUTPUT** cable and connector:
 - The rated DC output voltage of the MPC is below the level considered hazardous.
 - The DC output terminals of the MPC are isolated from the AC input with reinforced safety insulation.
 - However, never assume the terminals of the DC output connector or the wires of the DC output cable are safe to contact, even if the MPC appears to be off.

Hazardous Energies

The **INPUT AND OUTPUT POWER** connectors and cables of the SynQor MPC may be the source of high levels of energy. Do not inappropriately make electrical contact between any terminal of a connector and another, or between any wire of a cable and another, or between any terminal or wire and the MPC's chassis or ground. **DAMAGING ELECTRICAL ARCS** may result. Care should be taken to avoid accidental electrical contacts of this sort.

Protection from the Environment

The SynQor MPC is a ruggedly built product having its electronics contained in sealed chambers. It is capable of withstanding harsh levels of mechanical acceleration, shock and vibration, temperature and pressure variations, and exposure to water, salt, sand and dust within the levels specified in the data sheet. **THESE LEVELS SHOULD NOT BE EXCEEDED.**

Do not obstruct the air intake in the front of the MPC or the fan exhausts in the rear panel of the MPC while the MPC is operating.

User Serviceable Parts

MPC-1250 DC Output Series fans are user replaceable with kits available from SynQor. Please contact the SynQor factory for obtaining fan replacement kits and instructions (Replaceable Fan Module SYN-9450). The MPC-1250 DC Output Series has no other user serviceable parts inside of it. **DO NOT REMOVE** the cover of the unit or any of its connectors. Other than the fan assembly replacement, only factory trained personnel should perform repairs.

Product Description

The SynQor MPC-1250 DC Output Series is an advanced technology Military Power Conditioner (MPC) that uses highly efficient power electronic circuitry to achieve a high power level in a low-profile, low-weight, rack-mountable package. It provides voltage conditioning, electrical isolation, and power flow smoothing between the power inputs and its power outputs.

A communication/control port is available to permit monitoring and control by a host computer system. Front panel LEDs and an audible alarm provide information on the status of the MPC.

The MPC-1250 DC Output Series products can draw power from an AC input having a wide range of voltage and frequency levels, or from an 28 V nominal DC input. The AC input has priority over the DC input. The MPC provides up to 1250 W of DC output power at 24, 28 or 48 V depending on which model is selected. The “Constant Current” model is designed to charge lead-acid batteries used in 28 V vehicle power applications.

The electronic circuitry within the MPC-1250 DC Output Series products is designed, qualified and screened according to SynQor’s MIL-COTS Standards. It complies with the requirements of MIL-STD-704F, MIL-STD-1399-300B, MIL-STD-1275D and MIL-STD-461F, as well as IEC-EN61000 specifications for world-wide commercial utility applications.

The MPC-1250 DC Output Series products are designed and manufactured to withstand the harsh environments and use encountered in military applications. The electronic circuitry is contained in a sealed chamber constructed from a die-cast aluminum chassis that is weather-proof and shock-proof. Redundant, water-proof fans on the rear panel draw cooling air over the heat-sink fins below the sealed chamber. Military-grade circular connectors are used, and optional attached connector covers are available for when the cables are not attached. The MPC-1250 DC Output Series products comply with a wide range of testing according to MIL-STD-810G.

The SynQor MPC-1250 DC Output Series products are designed and manufactured in the U.S.A.

Product Topology

The SynQor MPC-1250 DC Output Series products use a true on-line double conversion topology that provides protection to the load from spikes, noise, surges, brownouts, blackouts, etc. in the input power sources. They also provide smoothing of load transients and nonlinear load profiles so that the input power sources are not subjected to these disturbances. There is a seamless transfer from any power source to another so that there is no disruption in the output voltage waveform.

As the figure below shows, there is a nominal 28 V mid-bus within the MPC that draws power from one of up to two power sources: the AC INPUT or the DC INPUT (with that order of priority based on availability). EMI filters are present at all external inputs and outputs.

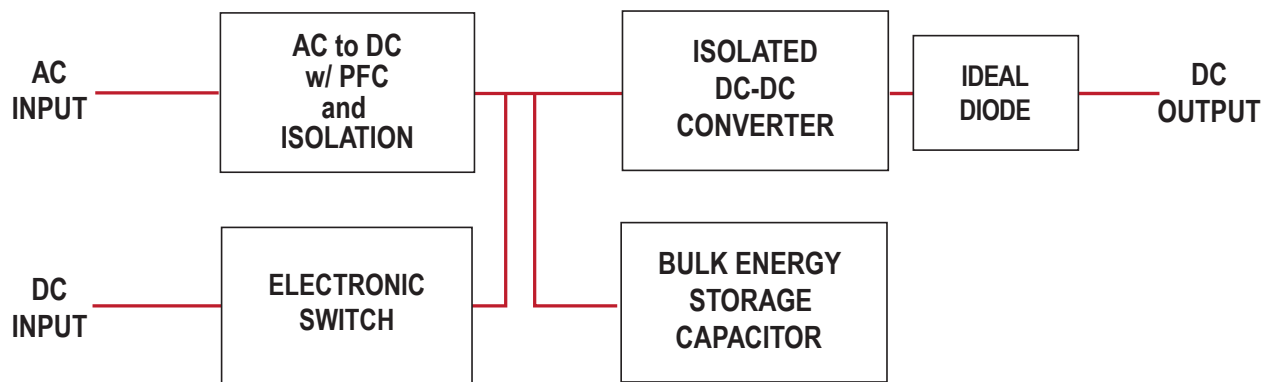

Power flows from the AC INPUT through an AC-DC converter that has Power Factor Correction (PFC) and high-frequency safety isolation. Power flows from the DC INPUT through an electronic switch that is closed when the AC INPUT power is absent and the DC INPUT voltage is within its specified range.

The DC output can deliver up to 1250 W. The DC output is isolated from the AC input.

Bulk energy storage capacitors are connected to the mid-bus to help smooth imbalances in power flow between the inputs and output of the MPC.

There is a communication/control port that provides a digital interface to a host computer system.

Part Numbering Scheme and Options

This table shows the part numbering scheme for the full line of SynQor MPC products:

Base Models			
Model Number	Power	Height (W x D x H)	Weight
MPC-1250-1S	1250 W	1U (17.00" x 14.80" x 1.73")	22 lbs.

Base Model	Options						Options	
	AC Input Frequency	DC Regulation Type	DC Output Voltage	DC Input	Additional Options		AC Input Freq	DC Reg
MPC-1250-1S-	L W	R P C	24 28 48	D00	-E	00 CE	L 47 - 65 Hz W 47 - 800 Hz	R Fully Regulated, No Paralleling P Fully Regulated with Paralleling C Constant Current Overload Protection
							24 24 V Output * 28 28 V Output * 48 48 V Output *	
							D00 DC Input	
							-E Ethernet/SNMP with Configuration Loading	
							00 No CE Marking CE CE Marking	

Not all combinations make valid part numbers, please contact SynQor for availability. See the Product Summary web page for more options.

Examples:

MPC-1250-1S-LR28D00-E00, MPC-1250-1S-WP24D00-E00, MPC-1250-1S-LR28D00-ECE (Fully Regulated with CE Marking)

The MPC-1250 DC Output Series of products provide up to 1250 W of total output power (DC).

Various options can be specified according to the part numbering scheme shown in the table:

- The allowable frequency of the AC INPUT can either be in the 47-65 Hz range (for 50 Hz and/or 60 Hz systems) or in the 47-800 Hz range (for 400 Hz and Variable Frequency systems)
- The output voltage of the MPC-1250 DC Output Series can be 24, 28 or 48 V nominal.
- There is a DC INPUT that is specified to comply with MIL-STD-704F and MIL-STD-1275D for 28 V systems
- “Constant Current” DC output for charging lead-acid batteries used in 28 V vehicle power applications.
- RS232 serial port and logic-level I/O communication are included in the standard model. An Ethernet port provides web and SNMP interfaces.

Electrical Characteristics

INPUT CHARACTERISTICS

Operating AC Input

Voltage	80 - 265 Vrms*
Frequency	47 - 65 Hz (47 - 800 Hz Optional)
Input Power Factor	>0.98 at 47 - 65 Hz >0.97 at 400 Hz >0.93 at 800 Hz
Maximum Input Current Continuous	20 A (full load, 85 Vrms)
AC Input Circuit Breaker Rating (* Power Derating to 80 % below 90 Vrms)	25 A

Operating DC Input

Voltage	22-33 V
Continuous Maximum Input Current	62 A (full load, 22 V)
Transient Maximum Input Current	75 A
Reverse Polarity Protection	-60 V

OUTPUT CHARACTERISTICS

Output Power Continuous	1250 W
Voltage Setpoint Accuracy	± 3 %
Voltage Regulation (Over Load & Temperature)	± 5 %

DC Output - Fully Regulated

24 V Option

Voltage Setpoint (Nominal)	24 V
Rated Output Current	52 A
Overload Current Maximum (< 1 sec)	60 A
Reverse Polarity Protection	None

28 V Option

Voltage Setpoint (Nominal)	28 V
Rated Output Current	45 A
Overload Current Maximum (< 1 sec)	60 A
Reverse Polarity Protection	None

48 V Option

Voltage Setpoint (Nominal)	48 V
Rated Output Current	26 A
Overload Current Maximum (< 1 sec)	45 A
Reverse Polarity Protection	None

DC Output - Constant Current

28 V Option

Voltage Setpoint (Nominal)	28 V
Rated Output Current	45 A
Overload Current (Continuous)	47 A
Output Vampire Current - Unpowered	< 2 uA
Reverse Polarity Protection	-60 V

RELIABILITY CHARACTERISTICS MIL-HDBK-217F

MTBF 100 kHrs MIL-217F Ground Benign, Ta=25 °C

ELECTROMAGNETIC CAPABILITY MIL-STD-461F

CE101**	30 Hz - 10 kHz
CE102	10 kHz - 10 MHz
CS101	30 Hz - 150 kHz
CS106	Pulse Transient
CS114	10 kHz - 200 MHz
CS116	10 kHz - 100 MHz
RE101	30 Hz - 100 kHz
RE102	10 kHz - 18 GHz
RS101	30 Hz - 100 kHz
RS103	2 MHz - 40 GHz

** Regarding MIL-STD-461 CE-101, the 50 uH series inductance of a standard LISN adversely affects the input ripple of the MPC (DC input only). Such a large series source inductance (50 uH in each power lead) is not generally encountered in a 28 V DC source of such high power rating. Therefore, testing for CE-101 (DC input) was conducted with 3 different configurations: two using 50 uH LISNs and a 54 mF capacitor connected across the input to the MPC, and one using 5 uH LISNs for which no additional capacitor was added.

These configurations all passed CE-101 for all frequencies.

MECHANICAL CHARACTERISTICS

Chassis

Chassis Width	17.00 "W
Chassis Depth	14.80 "D
Chassis Height	1.73 "(1U)H
Case Material	Aluminum
Total Weight	22 lbs.

Cooling Exhaust Fans

Sound Pressure Level (SPL)	54 dB(A)
Air Flow	0.67 (m ³ /min) 23.7 CFM

Two fans in system, above specs are for each fan separately.

MECHANICAL CONNECTORS

Connectors

AC Input Connector	MS3470L14-4P
User I/O Ports	HD DB15 Female
Configuration I/O Port	HD DB15 Male
Ethernet Port	Amphenol RJF22N00, Code B
DC Input Connector	MS3470L18-8P
DC Output Connector	MS3470L18-8S

ENVIRONMENTAL CHARACTERISTICS MIL-STD-810G

Temperature Methods 501.5, 502.5

Operating Temperature	-40 °C to 70 °C ¹
Storage Temperature	-40 °C to 70 °C

Altitude Method 500.5

Operating	0 - 18,000 ft
Non-operating	0 - 40,000 ft

Environmental Tests

Shock/Drop	Method 516.6, Procedures 1,4,6
Temperature Shock	Method 503.5, Procedure 1
Vibration	Method 514.6, CAT 5, 7, 8, 9, 24
Fungus	Method 508.6
Salt Fog	Method 509.5
Sand and Dust	Method 510.5, Procedures 1,2
Rain	Method 506.5 Procedure 1
Humidity	Method 507.5 Procedure 2
Mechanical Vibrations of Shipboard Equipment	Method 528 Procedure 1

¹ 100 % rated power at 55 °C, 0 % rated power at 70 °C.
Derate linearly.

Product Specifications

The following three pages show the electrical and mechanical specifications of the MPC-1250-S-1S Series of products. Data sheets showing these specifications and other information can be found at the web site. <https://www.synqor.com/MPC>

MPC-1250-1S

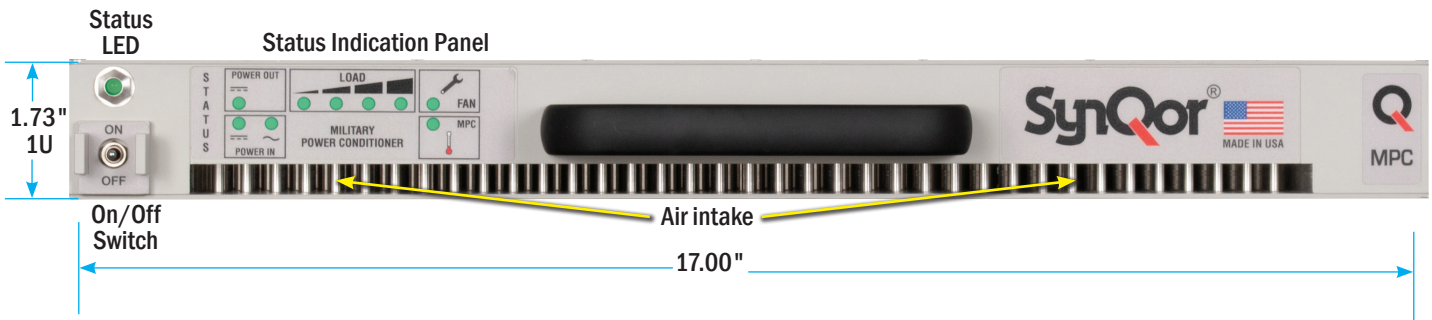

MPC-1250-1S With Constant Current Output



MPC-1250-1S with AC & DC Input / DC Output

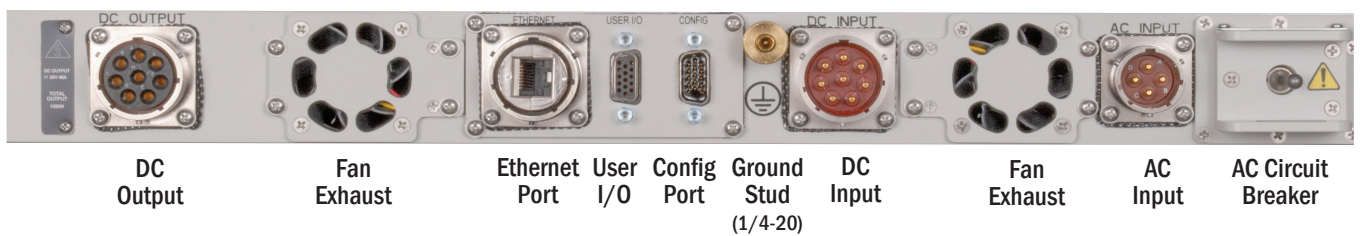

MPC-1250-1S 1U Mechanical Diagram

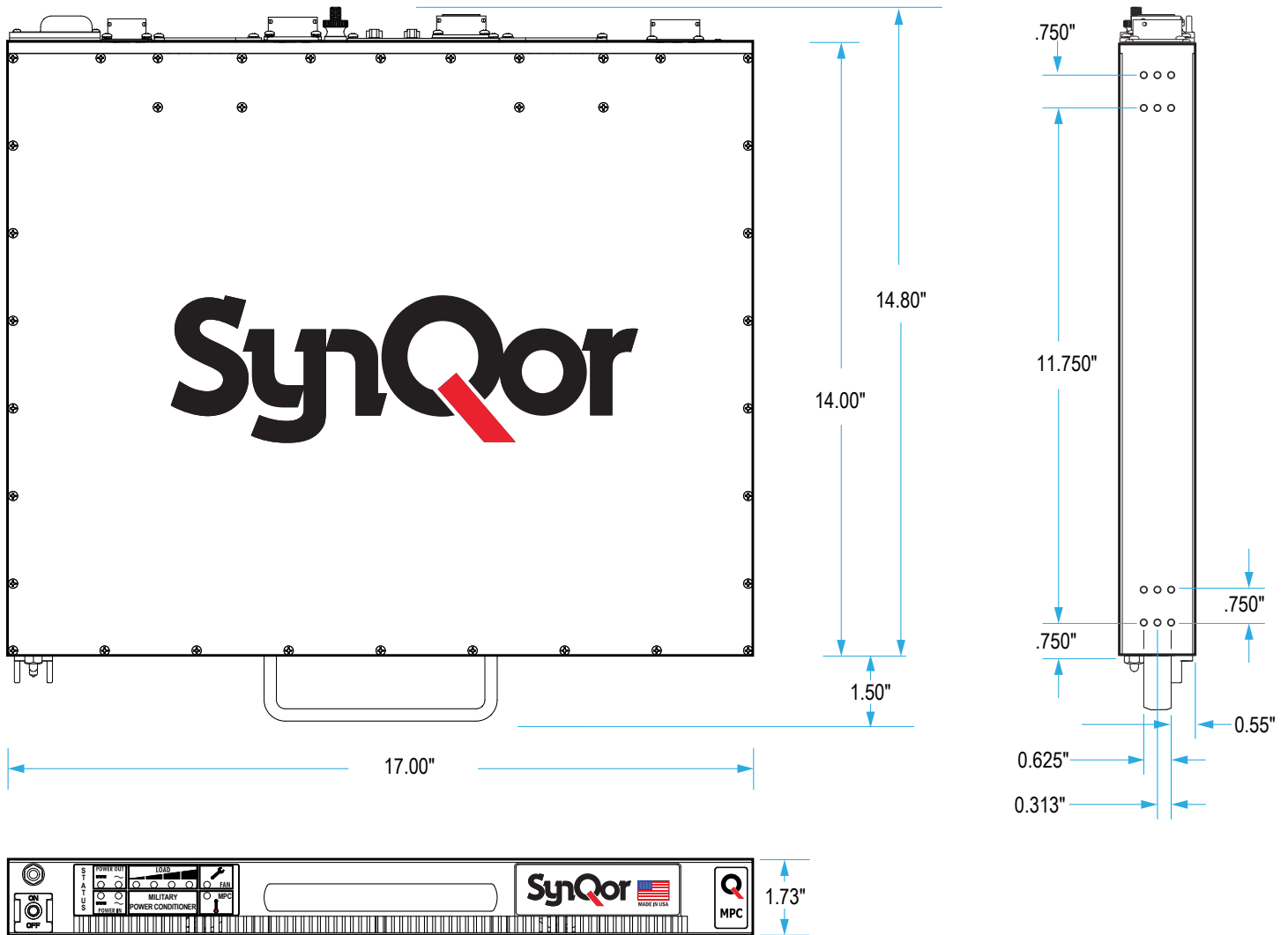

MPC Efficiency

Figure 1 shows the typical efficiency with which the MPC-1250 DC Output Series uninterruptible power supplies delivers power to its DC OUTPUT from a 22, 28, and 33 volts input.

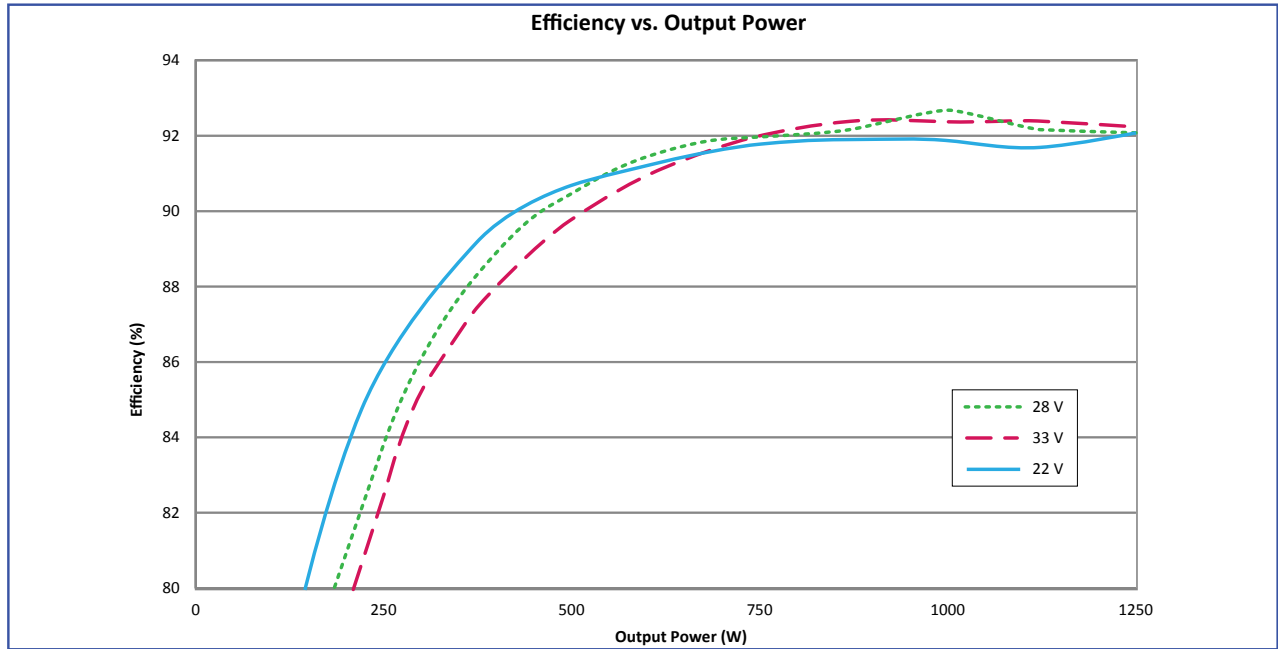

Figure 1

Figure 2 shows the typical efficiency with which the MPC-1250 DC Output Series uninterruptible power supplies delivers power to its DC OUTPUT from 115 VAC and 230 VAC input.

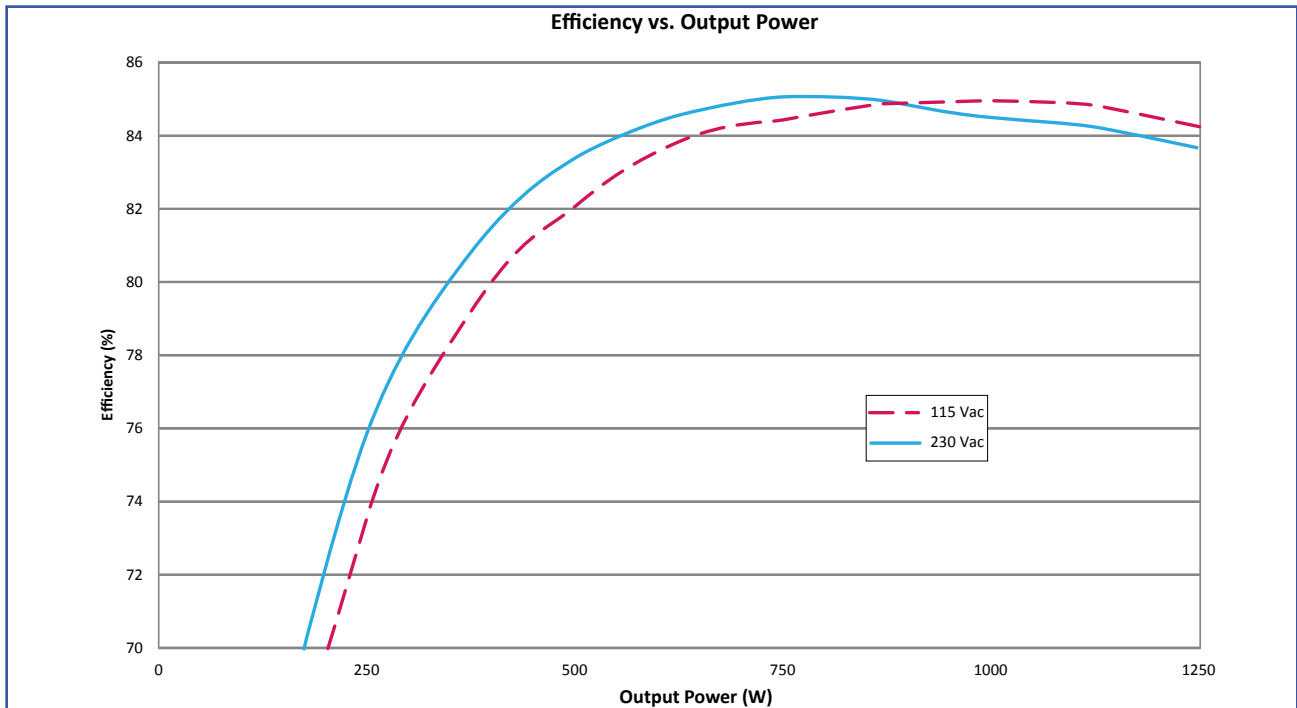

Figure 2

Total Output Power that can be derived from the AC INPUT

The total MPC output power for the MPC-1250 DC Output Series is rated at 1250 W for an ambient temperature as high as 55°C (131°F). It draws this power first from the AC INPUT (if its voltage is within range) and then the DC INPUT (if its voltage is within range).

However, when the AC INPUT voltage is at the low end of its range (<90 Vrms) or the ambient temperature is at the high end of its range (>45°C/113°F) the MPC will not be able to deliver its full rated output power in the steady-state without switching over to either the DC INPUT (if it is available and >22 Vdc). Figure 4 indicates the total steady-state output power that the MPC can derive **from the AC INPUT** under these extreme conditions. See Figure 3 for information on transient conditions.

- If the AC INPUT voltage is above 105 Vrms, then the MPC can deliver its full rated output power of 1250 W from the AC INPUT for an ambient temperature as high as 55°C (131°F) without needing to switch over to the optional DC INPUT.
- If the AC INPUT is between 90 Vrms and 80 Vrms then the total output power that can be derived from the AC INPUT linearly decreases from 1250 W at 90 Vrms to 1000 W at 80 Vrms (except for at the high end of the ambient temperature range – see below). For example, the total output power that could be derived from the AC INPUT would be 1125 W at 85 Vrms as long as the ambient temperature is not above 50°C (122°F). If the total output power is greater than this derated value, the MPC will switch to the DC INPUT (if it is available and >22 V).
- If the AC INPUT voltage is 90 Vrms **AND** the ambient air temperature is above 45°C (113°F), the total output power that can be derived from the AC INPUT linearly decreases from 1250 W at 45°C (113°F) to 1000 W at 55°C (131°F). For example, the total output power that could be derived from the AC INPUT would be 1125 W at an AC INPUT voltage of 90 Vrms and an ambient temperature of 50°C (122°F). A higher output power than this would cause the MPC to switch over to its DC INPUT.
- When the AC INPUT voltage is between 105 Vrms and 90 Vrms **AND** the ambient temperature is between 45°C and 55°C, the total output power that can be derived from the AC INPUT can be calculated by linearly interpolating between the curves shown. For example, the total output power that can be derived from the AC INPUT when the voltage is 97.5 Vrms would be 1250 W up to an ambient temperature of 50°C (122°F) and then derate to 1125 W at 55°C (131°F).

Furthermore, there is a limited (and uncommon) range of AC INPUT voltage between 132 Vrms and 160 Vrms in which the total output power that can be derived from the AC INPUT is also derated, as shown in Figure 3.

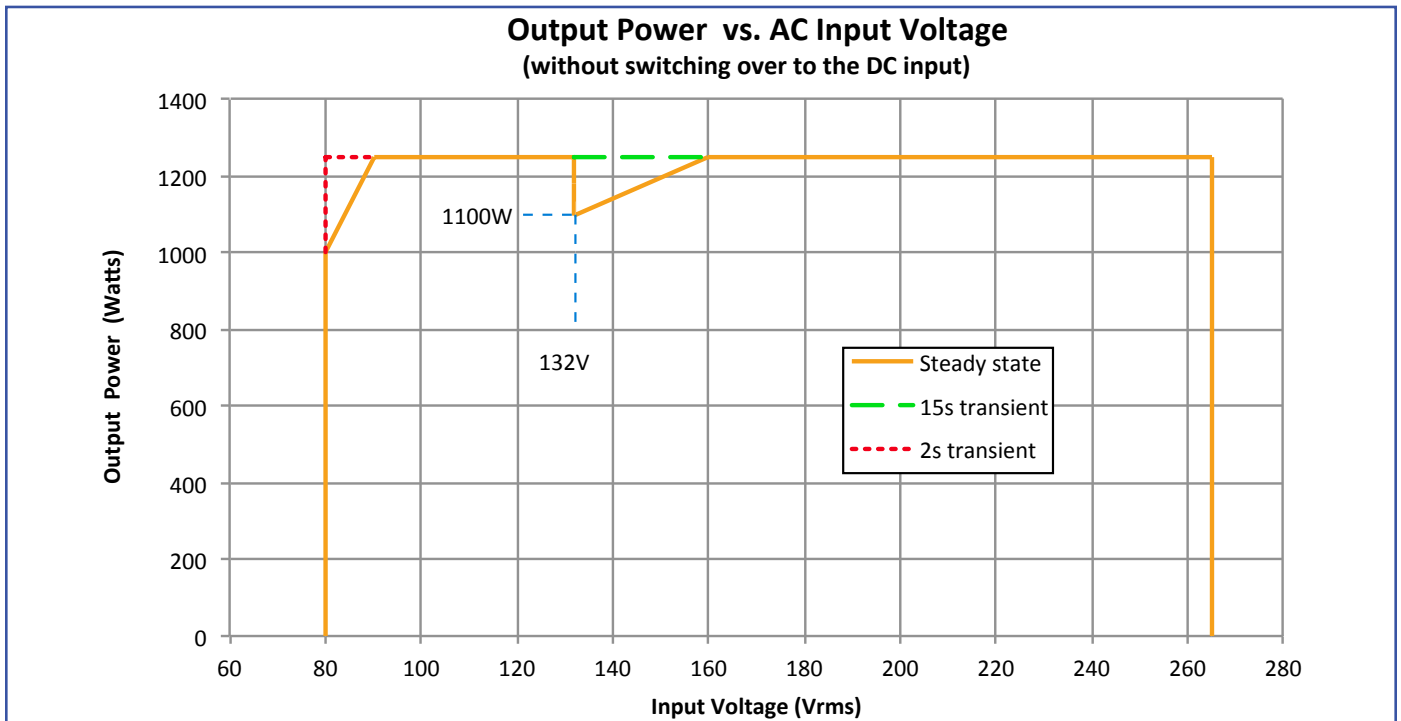

Figure 3

Note that the full rated output power of 1250 W can be derived from the AC INPUT having a voltage within this uncommon range for 15 seconds before the MPC will switch over to the DC INPUT. Also note that the MPC can drive it full rated power for a 2 second interval even if the AC INPUT voltage drops below 90 Vrms.

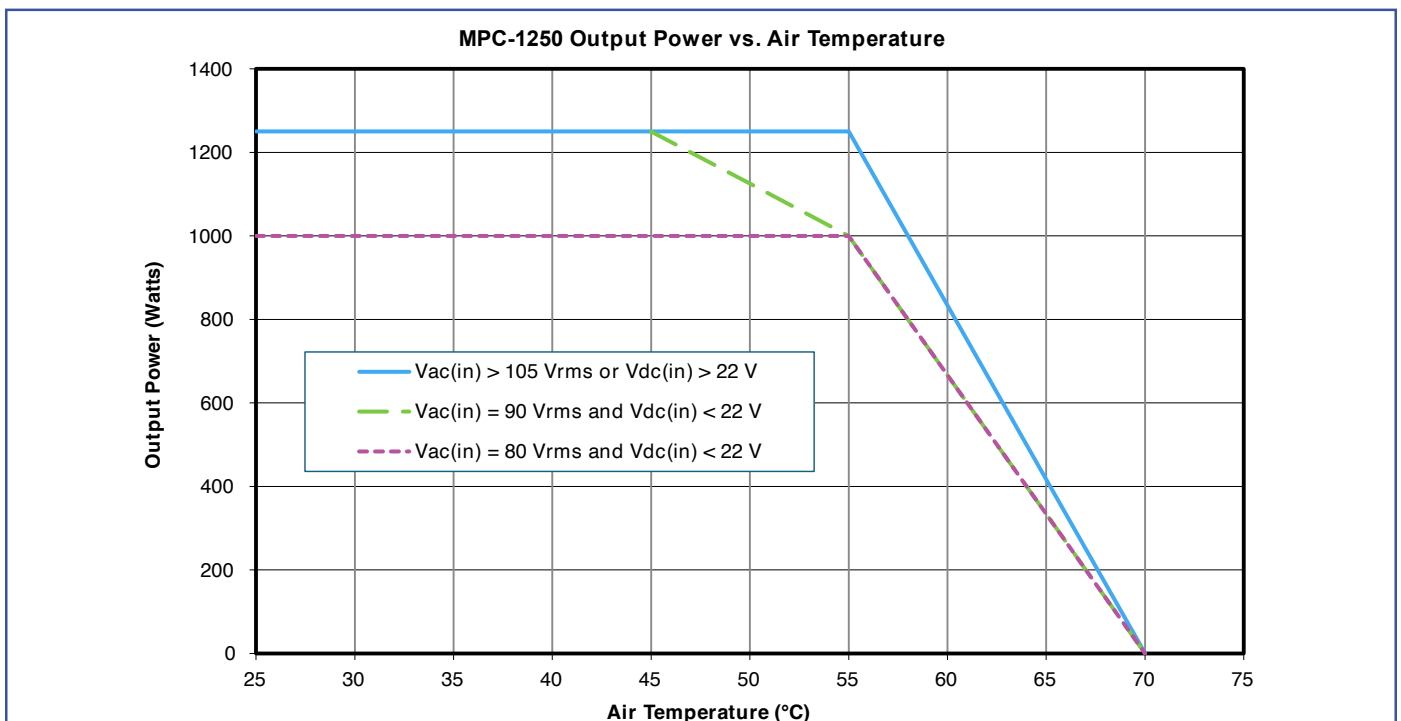
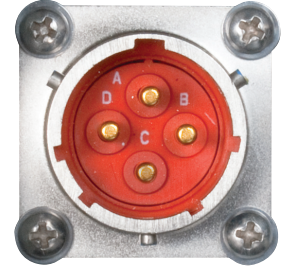
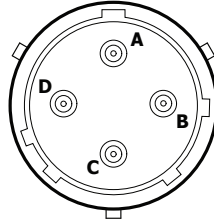

Figure 4

Power Cable Wiring Diagram

Looking at the rear panel, the MPC connector terminals have the following functions and locations:

AC INPUT	
Pin	Function
A	Line
B	Neutral
C	No Connect
D	Ground



DC INPUT	
Pin	Function
G, F, E	+V _{IN}
B, C, D	V _{IN} Return
A, H	No Connect

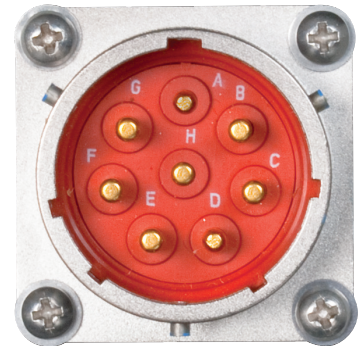
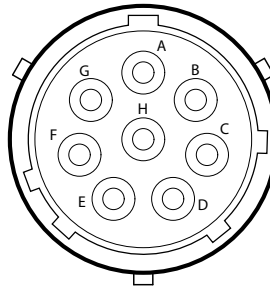

DC OUTPUT	
Pin	Function
G, F, E	+V _{OUT}
B, C, D	V _{OUT} Return
A, H	No Connect

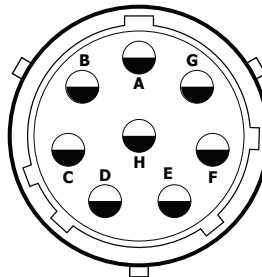

Power Cable Wire Size

SynQor recommends the following cables for use with the MPC-1250 DC Output Series:

AC Input:	SYN-9101	MPC connection to NEMA 5-20 Plug, 10'
	SYN-9104	MPC connection to NEMA 5-15 Plug, 10'
	SYN-9102	MPC connection to Hardwire Termination, 10'
DC Input:	SYN-9151	MPC connection to Ring Connectors, 10'
	SYN-9154	MPC connection to NATO Connector, 10'
DC Output:	SYN-9174	MPC connection to Harwire Termination, DC Output, 10'
	SYN-9175	MPC connection to Fork Connectors, DC Output, 10'

Other options may be available. Contact info@synqor.com or visit the website: <https://www.synqor.com> for more information. If it is necessary to develop custom cables for your application, please read through the following section for some important considerations. Damage caused by improper wiring of cables will not be covered under SynQor's warranty.

Both the input and output cables of the MPC carry substantial current, and since the wires in these cables have resistance the current flowing through them causes a voltage drop from one end of the cable to the other. In other words, the voltage across the cable at its downstream end is smaller than the voltage across the cable at its upstream end. Mathematically, the amount that the voltage drops is equal to the resistance of the cable's wire multiplied by the current flowing through the wire. It is therefore **important** to make sure that the **resistance of the cable's wire is small** enough to keep this voltage drop to an acceptably small value.

While this is an issue for all of the power cables, **it is particularly important for the DC INPUT and DC Output cables** because the current flowing through it is very high (as high as 65 A for the MPC-1250 DC Output Series) and the voltage across it is already relatively small (as low as 22 V). In fact, a common problem that arises (when the DC INPUT cable has too small a wire) is that the voltage seen at the DC INPUT of the MPC falls below the minimum specified value of 22 V even though the voltage at the source of the DC power is greater than 22 V.

The resistance of a wire depends directly on its length. A wire twice as long as another will have twice the resistance, holding all other things constant. The resistance also depends on the reciprocal of the cross-sectional area of the wire, which in turn depends on the square of the wire's diameter. A wire with half the diameter of another will therefore have four times the resistance, holding all other things constant.

Therefore, the longer a cable is, the more important it is that the wire's diameter be large. Alternatively, a cable can have multiple pairs of wires to achieve a larger "effective wire diameter". This second approach gives a more flexible cable. For 10 ft long cables, SynQor recommends that for the MPC-1250 DC Output Series:

- The AC INPUT cable has 3 wires (one for the ground) of 12 AWG
- The DC INPUT cable has 6 wires (three for each connection) of 12 AWG
- The DC OUTPUT cable has 6 wires (three for each connection) of 12 AWG

Additional details about the effects of a resistance-related voltage drop are included in "Trouble-Shooting Guide - Cable wire resistance is too high".

Set-Up

The recommended procedure for setting up the MPC is the following:

- Make sure the AC BREAKER on the rear panel of the MPC is in the OFF position.
- Connect the ground wire to the ground stud on the rear panel of the MPC.
- Connect all OUTPUT cables, first to the MPC and then to the various loads.
- **VERIFY** that the DC OUTPUT cable is connected to the MPC and the load with the correct polarity.
- Connect the USER I/O cables.
- Connect all INPUT cables, first to the MPC and then to the various sources.
- An overcurrent protect and disconnect device should be installed on the DC INPUT circuit. An example of a suitable device is a Carling Technologies, C-series, 80 A 65 VDC, CA1-B0-14-680-321-J circuit breaker. (www.carlingtech.com)
- **VERIFY** that the DC INPUT cable is connected to the MPC and the source of DC power with the correct polarity.
- Turn on the sources (if they have an upstream breaker).
- Move the AC BREAKER on the rear panel of the MPC to the ON position.

Note: Be careful to not toggle the ON/OFF switch during the setup. Doing so could cause the MPC to turn on and present a hazardous voltage at its output.

Start-Up

- **VERIFY** that all connections to the MPC are correct.
- If either the AC source or the DC source (or both) is present and within specifications, the color of the LED above the ON/OFF switch will be amber. This indicates that the MPC is in standby mode and ready to turn on. The front panel LEDs will also be appropriately illuminated.
- Momentarily push the ON/OFF switch on the front panel of the MPC upward. The switch can then be released and it will return to its normal (neutral) position.
- The MPC will immediately enable its output (assuming there is no fault condition). The color of the LED above the ON/OFF switch will change to green. The LEDs on the front panel will indicate the amount of power being delivered to the load and the input source from which this power is being drawn.

Shut-Down

- Shut down the equipment connected to the MPC.
- Push the ON/OFF switch on the front panel of the MPC downward and hold it in this position for 1 second (or more). The color of the LED above the ON/OFF switch will change to amber (if one or both input power sources are present) or it will be off (if no power sources are present). The switch can then be released to return to its normal position.
- The MPC will disable its output and shut down.
- The front panel LEDs will either be appropriately illuminated (if one or both input power sources are present) or they will be off (if no power sources are present).
- It is not necessary to move the AC BREAKER on the rear panel of the MPC to the OFF position.

Power Cable Connections/Disconnections While Operating

For safety reasons, it is highly recommended that the input and output power cables be connected to the MPC before the source of AC or DC input power is turned on, and before the MPC is turned on (see **Section I: Warnings** and the **SET-UP** section above). Similarly, it is **highly recommended** to first turn off the MPC and the sources of input power before any power cables are disconnected from the MPC.

However, the SynQor MPC is capable of having any of its input or output power cables connected at any time (if safely done), including when the MPC is turned on and delivering power to the load. For instance:

- Even if the MPC is turned on, one can connect or disconnect the input power cables without harming the MPC or disrupting power delivery to the load. If no input power source is available, the MPC will shut down. When there is an external source of power connected to the MPC, the unit will draw power from that source, choosing the AC INPUT source first, if present, and then the DC input source. The transfer from one source of power to another is seamless.
- Even if the MPC is turned on, one can connect or disconnect an output power cable without harming the MPC or disrupting power delivery to a load that might be connected to the other output.

NOTE that disconnecting an input or output power cable while that cable is handling power will likely cause an arc to form as the terminals are pulled apart. This arcing is not harmful to the MPC, although if done enough times it will degrade the connector to the point where it will need to be replaced. This problem is particularly acute for the **DC INPUT cable** because its current is so high. Disconnecting this cable while a large current is flowing is **not recommended**.

ALSO NOTE that when the MPC is turned on and delivering power to a load, and then another piece of equipment is connected to the same output, it is possible that this connection will momentarily disrupt the quality of the MPC's output voltage. If the MPC is turned on and delivering power to several loads and then another load is connected, it is possible that this new load will momentarily draw a large surge of current as it starts up. If this happens, the output of the MPC could reach its maximum current limit, and the MPC will reduce its output voltage to keep the current from getting any larger. This reduction in voltage will be corrected once the new load reaches its normal mode of operation, but in the mean time the reduction of the MPC's output voltage might cause one or more of the other loads to malfunction. Whether or not this will be a problem depends on the characteristics of the various loads.

Cooling System

The SynQor MPC-1250 DC Output Series products are cooled by fans that draw air into the intake below the front panel on the front panel and exhaust it out the two fan ports on the rear panel. Care should be taken to ensure there is no obstruction to this airflow, either at the front intake or the rear exhaust ports. Similarly, care should be taken to avoid obstructing the fan blades.

The speed of the cooling fans is automatically controlled to provide adequate MPC cooling while extending the life of the fan bearings. Under low ambient temperature and/or low MPC output power the fans will be driven at a low speed. If the ambient temperature and output power are such that the MPC cannot otherwise maintain its specified maximum temperature for its internal circuitry, the fans will momentarily be driven at a speed that exceeds their rated long-term running speed. There is an LED on the front panel that indicates the speed of the fans.

If the ambient temperature is low enough (for the level of power being delivered to the load), the fans may not be on. This is not a malfunction. It is done to preserve the life of the fans. If the fans are off, check the Fan Service Required LED on the front panel. If it is GREEN, the fans are functioning properly and simply not needed under the present conditions.

The fans are weather-proof and water-proof.

The MPC has two fans to provide redundancy for these exposed, moving components. With only a single operating fan the MPC is still able to deliver 100% rated power at an ambient temperature as high as 40°C, and it is able to deliver 80% of its rated power at an ambient temperature as high as 55°C.

Front Panel Indicators

To indicate the status of the MPC, there is one LED above the ON/OFF switch on the left side of the front panel of the MPC and an additional 10 LEDs on the front panel. There is also an audible alarm. These indicators are described in this section.

LEDs

LED above the ON/OFF switch

This LED has four possible indications, according to the table below:

LED Appearance	Description	Indication
	Green	MPC is Running <i>(Outputs are Enabled)</i>
	Amber	MPC is on Standby <i>(Outputs are Enabled)</i>
	Red	MPC has a Fault Condition
	Off	MPC is Off

LEDs on the Front Panel - “Regulated” and “Parallel” Models

The “Regulated” and “Parallel” models each have a 10 LED front panel display to indicate the status and operation of the MPC. LED A1 is permanently disabled. There is no AC outlet on the unit.

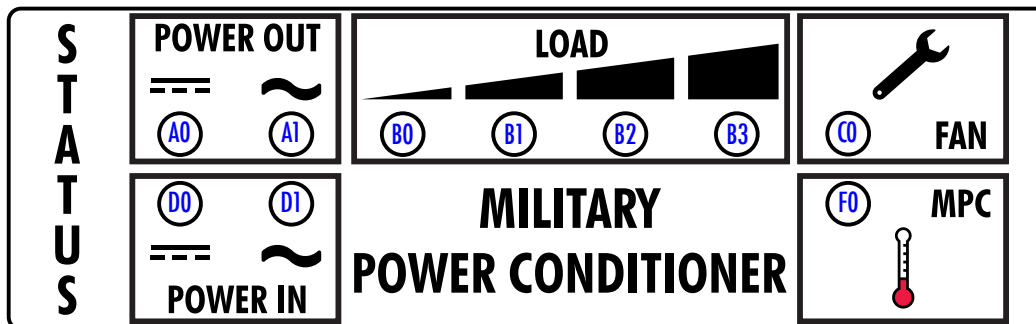

LEDs on the Front Panel - “Constant Current” Model

The “Constant Current” model has a 13 LED front panel display to indicate the status and operation of the MPC.

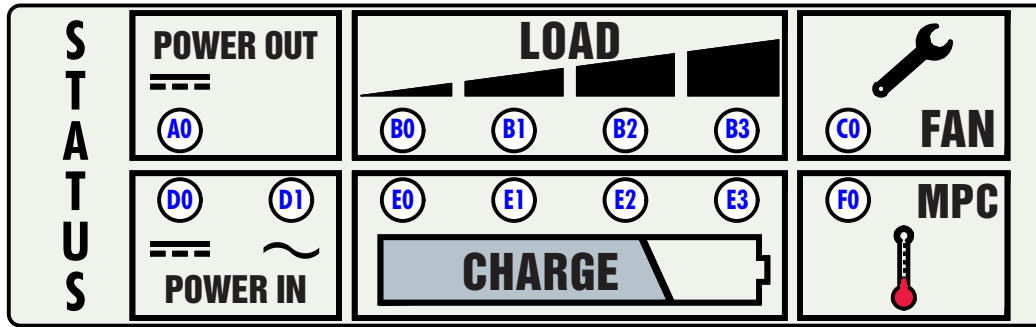

Power-In Indicators (LEDs in positions D0 and D1)

The LED in position D0 indicates the status of the optional DC INPUT and the LED in position D1 indicates the status of the AC INPUT, according to the table below:

LED Appearance	Description	Indication
	Green	<i>Input is Ready to Provide Load Power</i>
	Pulsing Green	<i>Input is the One Presently Selected as the Source of Power</i>
	Amber	<i>Input has Returned within Range and Diagnostic Tests are Being Performed</i>
	Off	<i>Input is Not within Range</i>

Power-Out Indicator (LED in position A0)

The LED in position A0 indicates the status of the DC OUTPUT, according to the table below:

LED Appearance	Description	Indication
	Green	<i>MPC is On and the Output Voltage is Within Range</i>
	Amber	<i>MPC is On but the Output Voltage is Out of Range</i>
	Red	<i>MPC is Off and the Output Voltage is Within Range</i>
	Off	<i>MPC is Off</i>

Load Power Indicators (LEDs in positions B0 – B3)

The LEDs in positions B0 through B3 indicate the output power of the MPC according to the table below:

LED Appearance	Description	Indication
	<i>B0 Dimmed Green; B1-B3 Off</i>	<i>Total Load Power <25%</i>
	<i>B0 Green; B1 Dimmed Green; B2-B3 Off</i>	<i>Total Load Power <50%</i>
	<i>B0, B1 Green; B2 Dimmed Green; B3 Off</i>	<i>Total Load Power <75%</i>
	<i>B0, B1, B2 Green; B3 Dimmed Green</i>	<i>Total Load Power <100%</i>
	<i>B0; B1; B2 Green; B3 Blinking Red</i>	<i>Total Load Power ≥100%</i>

MPC Cooling System Indicator (LED in position F0)

The LED in position F0 indicates the temperature and status of the cooling system for the MPC according to the table below:

LED Appearance	Description	Indication
	Green	<i>Moderate MPC Temperature (Fans Running at 33%)</i>
	Blinking Green	<i>Warm MPC Temperature (Fans Running at 67%)</i>
	Amber	<i>Elevated MPC Temperature (Fans Running at 100%)</i>
	Red	<i>Maximum MPC Temperature (Fans Running at 110%)</i>







Fan Service Required Indicator (LED in position C0)

The LED in position C0 indicates whether the two cooling fans in the rear panel of the MPC are OK or if their performance is degraded, according to the table below:

LED Appearance	Description	Indication
	Green	<i>Both Fans are OK</i>
	Amber	<i>One or Both Fans Have Recently Had Degraded Performance and Diagnostic Tests are Being Performed</i>
	Red	<i>One or Both Fans Presently Have Degraded Performance</i>

External Battery Charge Level (Constant Current Model Only)

The LEDs in positions E0 through E3 indicate the output voltage, and can be used as a rough estimation for the charge of an external battery. The illumination levels of the LEDs are dependent on the user settable parameter Vset.

LED Appearance	Description	Indication
	<i>E0 Amber; E1, E2 E3 Off</i>	<i>Vout < 21 V</i>
	<i>E0 Dimmed Green; E1, E2, E3 Off</i>	<i>21 V < Vout < Vset Green LEDs illuminated proportionally to Output Voltage</i>
	<i>E0 Green; E1 Dimmed Green; E2, E3 Off</i>	
	<i>E0, E1 Green; E2 Dimmed Green; E3 Off</i>	
	<i>E0, E1, E2 Green; E3 Dimmed Green</i>	
	<i>E0, E1, E2, E3 Green</i>	<i>Vout ≥ Vset</i>

Aud ible alarm

For critical situations a pattern of audible tones will be repeated every 5 seconds, according to the table below. This audible alarm can be **silenced** by holding the ON/OFF switch on the front panel in the “UP” position until a chirp is heard. A new alarm condition will cause the audible alarm to be reactivated. Contact Factory for instructions on how to permanently silence the alarm.

Number of Tones in Pattern	Indication
Two	<i>Load Power is greater than or approaching 100% Rated Power</i>
Three	<i>Fault Appears on the DC Output MPC Must be Turned Off and Back On to Reset Fault</i>

Operating Environment

The SynQor MPC-1250 DC Output Series is designed for the extreme environmental conditions of military and aerospace applications. All the electronic circuitry is contained in a sealed, weather-proof, shock-proof chamber constructed of die-cast aluminum. Only the redundant, water-proof cooling fans are exposed to the environment. The MPC will shut down if it is too hot.

The MPC (with cables connected or connector covers installed) has been qualified to the following requirements of MIL-STD-810G:

MIL-STD-810G Test Method	Name	Procedure	Details
500.5	Low Pressure	I, II and III	<ul style="list-style-type: none"> ◆ 15,000 ft. operating ◆ 40,000 ft. storage
501.5	High Temperature	I and II	<ul style="list-style-type: none"> ◆ +55°C operating ◆ +65°C storage
502.5	Low Temperature	I and II	<ul style="list-style-type: none"> ◆ -20°C operating ◆ -40°C storage
503.5	Temperature Shock	I	◆ 10 cycles; >10°C/minute
506.5	Rain	I	<ul style="list-style-type: none"> ◆ 4" rain/hour ◆ 40 mph wind velocity
507.5	Humidity	NA	◆ >95%
508.6	Fungus	NA	◆ 28 day test
509.5	Salt Fog	NA	<ul style="list-style-type: none"> ◆ 5% salt solution ◆ 2 cycles (24 hr wet/24 hr dry)
510.5	Sand and Dust	I and II	<ul style="list-style-type: none"> ◆ 20 mph blowing dust ◆ 40 mph blowing sand
514.6	Vibration	Category 5	<ul style="list-style-type: none"> ◆ 5Hz (300 RPM) ◆ Loose Cargo
514.6	Vibration	Category 7	◆ General Exposure
514.6	Vibration	Category 8	◆ C-130 Aircraft level
514.6	Vibration	Category 9	◆ General Exposure
514.6	Vibration	Category 24	<ul style="list-style-type: none"> ◆ PSD = 0.04 g²/Hz; 20-2000 Hz ◆ Operating
516.6	Shock	I, IV and VI	<ul style="list-style-type: none"> ◆ 20 g/20 ms; 40 g/11 ms; 75 g/6 ms ◆ 48 inch drop in transit case ◆ 30 degree tilt and drop
528	Mechanical Vibrations of Shipboard Equipment	I	◆ Operating

Overview

The MPC-1250 Family offers a model designed to charge lead-acid batteries used in 28 V vehicle power applications. This model acts as a current source when overloaded, rather than going into a hiccup mode like the other MPC-1250 models. Hiccup mode allows other MPC-1250 models to deliver higher peak power, while constant current mode allows for battery charging.

The Constant Current model is designed to be connected directly to the terminals of a lead-acid battery. It will use the battery to ride through AC/DC source switch overs, and through load transients. The Constant Current model may shut down during these transients if a battery is not connected.

Lead-acid batteries use a Constant Current Constant Voltage charging profile (CCCV). The MPC-1250/C model has the following features to facilitate CCCV charging for a variety of different lead-acid batteries:

- Fixed 47 A charging current
- User adjustable nominal output voltage (V_{set}). Range is 22-33 V
- User adjustable “top off” voltage (V_{top}). Range is $V_{set} - 33$ V
- User adjustable “top off” time (T_{top}). Range is 0- 48 hours

User Settable Parameters – CCCV charging

Constant Current Constant Voltage Charging Overview

Lead-acid batteries charge with a Constant Current Constant Voltage charging profile, as shown in the figure below.

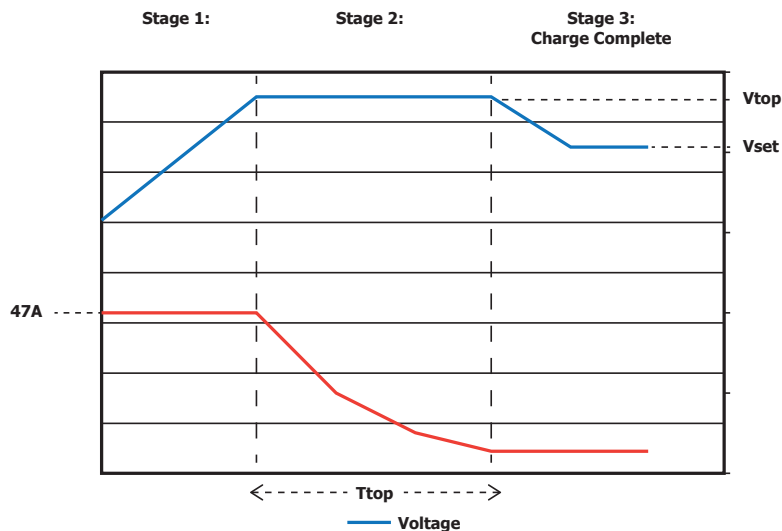

During Stage I, the battery charges with a Constant Current (CC). The MPC-1250 can supply 47 A in constant current mode. If no loads are active, the battery will charge with 47 A. If loads are active, the battery charge current will be reduced by the load current.

Once the battery voltage reaches the user settable “top off” voltage (V_{top}), the MPC transitions to Stage II. In Stage II, the battery finishes charging at a Constant Voltage (CV). The MPC-1250 default “top off” voltage is 29.4 V (V_{top}). As the battery finishes charging, the charge current decreases slowly until the “top off” time expires. The MPC-1250 default top off time is 8 hours.

Once the user-settable “top off” (T_{top}) time has expired, the MPC transitions to phase III. In phase III, the MPC is in normal operation. The output voltage is lowered to the user adjustable nominal value (V_{set}). The default value for V_{set} is 28 V.

Setting CCCV parameters

The CCCV parameters discussed in the previous section can be set two different ways:

- Serial commands via RS-232
- Web Page via Ethernet

The CCCV parameters can be set from the RS-232 interface using the following commands. See UPS User Commands document for details at:

https://www.synqor.com/document-download?document=UPS_User_Commands.pdf

- SET TTOP x [sec]
- SET VNOM x [mV]
- SET VTOP x [mV]

Example: Change V_{set} to 27 V
SET VNOM 27000

The CCCV parameters can be adjusted via the CONTROL tab on the web page:

Configuration	
Configuration settings are stored in non-volatile memory and will persist after power-down.	
Audible Output	Piezo alarm beep patterns indicate battery operation, output overload, critical battery charge level, and AC output failure. Audible output can be permanently muted with this configuration setting.
<input type="radio"/> On <input checked="" type="radio"/> Mute	
Autostart	With Autostart enabled, when UPS receives AC input power, it will enable the outputs automatically. Autostart only activates when the UPS is off - no input power and not running on battery.
<input checked="" type="radio"/> On <input type="radio"/> Off	
Fan Diagnostics	Fan diagnostics will cycle the fans through their speed ranges every 24 hours to monitor fan health.
<input checked="" type="radio"/> On <input type="radio"/> Off	
DC Output Nominal Voltage	Set nominal voltage [V] for DC Output.
<input type="text" value="28.000"/> <input type="button" value="SET VNOM"/>	
DC Output Top-Off Voltage	Set nominal voltage [V] for DC Out Top-Off Voltage.
<input type="text" value="30.000"/> <input type="button" value="SET VTOP"/>	
DC Output Top-Off Time	Set duration [sec] for DC Out Top-Off Mode.
<input type="text" value="28800"/> <input type="button" value="SET TTOP"/>	
Multi-Unit Control Synchronization	Through Config Port interconnect, Enable Events can be synchronized between devices. An enable event on one unit will cause all connected units to enable simultaneously.
<input checked="" type="radio"/> Enabled <input type="radio"/> Disabled	

The CCCV parameters cannot be read or adjusted via SNMP.

Over Power and Over Current Protection

The MPC-1250 for CCCV charging will act as a current source when overloaded. The current limit is fixed at 47 A. The output voltage will be reduced in order to maintain 47 A.

The MPC will run at 47 A indefinitely without shutting down. External breakers are not required to protect the MPC; however, an external breaker may be necessary to protect end use equipment. Low current loads with wires not sized for 47 A should be protected by a breaker or fuse.

In addition to the 47 A current limit, the MPC-1250 for CCCV charging has an Over Power limit. When Vset or Vtop are set above 27 V, the MPC is capable of delivering more than 1250 W. To prevent overloading the input sources, the MPC will regulate the output power to 1300 W by lowering the output voltage. The output voltage will rise to the user set value when the load is decreased below 1300 W.

Entering and Exiting Charge Mode

The MPC-1250 for CCCV charging will automatically enter and exit charge mode without user intervention.

If the MPC is in current limit for at least 30 seconds, it will assume it is recharging a battery, and enter the CCCV charging cycle. The MPC will recover from current limit when the output voltage reaches V_{top} .

If the MPC is in current limit for less than 30 seconds, it will assume there was a fault or overload that isn't a battery. The MPC will recover from current limit when the output voltage reaches V_{set} .

The MPC exits CCCV charge mode when the voltage has recovered to V_{top} and T_{top} has expired (Stage II has completed). To end Stage II early, the user can set T_{top} to a lower value.

Over Power protection will not cause the MPC to enter CCCV charge mode.

Visual indicators - External Battery Charge Level

LEDs E0 – E3 are unique to the Constant Current MPC-1250 model. These LEDs provide a rough estimate of the charge level of the external battery. See section VIII for details on all other from panel LEDs.

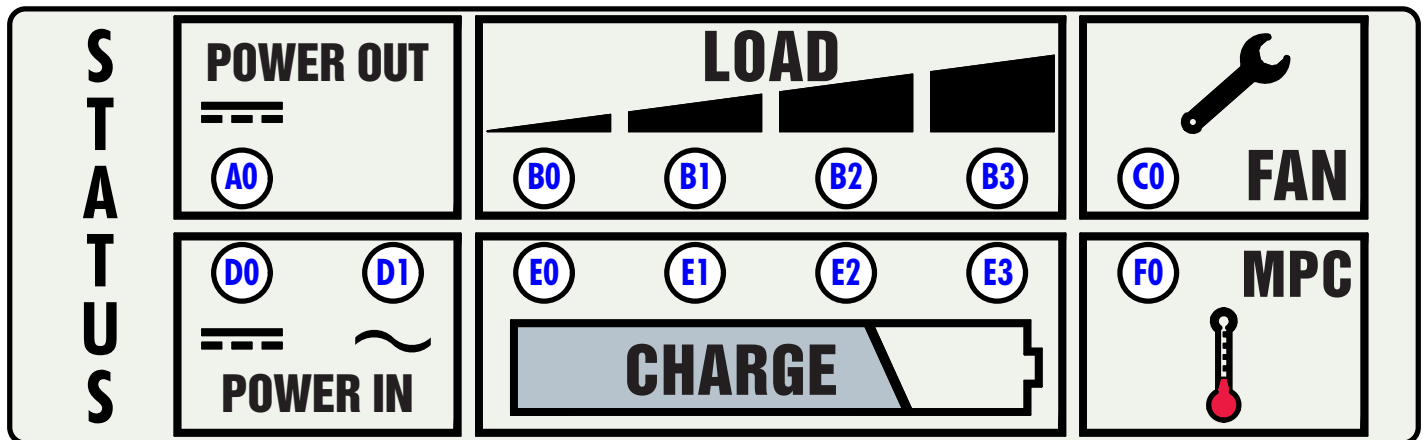

LEDs E0 – E3 provide a visual representation of the output voltage level. When the output voltage is close to the nominal (V_{set}), all four LEDs will be illuminated green. When the output voltage is below 21 V, LED E0 will be amber and E1-E3 will be off.

Note that the battery's output voltage is only an approximate indication of the charge level. The true charge level of the battery cannot be measured by the MPC-1250 since the MPC-1250 cannot differentiate between current delivered to the battery and current delivered to the end-use equipment. A third party battery monitor must be used to increase measurement accuracy of the battery's state of charge.

Output Vampire Current – Unpowered

When input power is unavailable, the constant current model is designed to draw $< 2 \mu\text{A}$ while connected to an external 28 V battery. This allows the MPC-1250 to remain connected to a battery for extended periods of time while in storage without the concern of discharging the battery. It is likely the self-discharge current of the battery will be higher than the MPC-1250 vampire current.

When input power is available and the MPC-1250 is not enabled, the vampire current increases to 250 – 450 μA , depending on the output voltage. The MPC-1250 output should be enabled periodically to keep the battery charged when input power is available.

Reverse Polarity Protection

The Constant Current model provides reverse polarity protection on the DC output. This prevents catastrophic damage in the event the output is connected to the battery terminals improperly. The Constant Current model is the only model that has reverse polarity on the output.

The MPC-1250 monitors the output voltage, and will not enable the output if it measures lower than -1 V. Once the output voltage is measured higher than -1 V, the output will respond to enable commands from the user. Note that all other features will still be available if reverse voltage is applied to the output. This includes indication LEDs, serial communications, and the web page.

The output is protected as low as -60 V. Applying a voltage lower than -60 V will cause permanent damage.

Unlike the DC output, the DC input includes reverse polarity protection for all models. The DC input is protected as low as -60 V. Applying a voltage lower than -60 V will cause permanent damage.

Parallel Connection of DC OUTPUTS – Parallel Option

MPC units with the regulated paralleling option can be paralleled with the proper configuration cable. Each unit transmits its output current over the configuration cable, allowing every unit to calculate the average output current. The units then trim their output voltage slightly in an attempt to deliver the average output current.

Sharing is optimized when the output resistance is matched between all parallel units. The output cables should have the same construction, similar length, and be connected at a single point.

Parallel Unit Ordering Information		
	Regulation Type	Example PN
Regulated Output (No Paralleling)	-R	MPC-1250-1S-1U-LR28D00-E00
Regulated Output with Paralleling	-P	MPC-1250-1S-1U-LP28D00-E00
Constant Current with Paralleling	-C	MPC-1250-1S-1U-LC28D00-E00

N+M Redundancy - Ideal Diode

The ideal diode on the DC OUTPUT provides N+M redundancy when multiple units are placed in parallel. An N+M redundant system consists of N units to supply the maximum load, and M additional units to provide redundancy. Typically, one additional unit is used for redundancy giving “N+1 redundancy”.

During normal operation, all N+M units will deliver power to the load. Should one unit fail, the remaining units will increase their output current to continue to power the load. The failed unit can be removed and replaced to restore the redundancy level of the system to its original design. The replacement unit can be inserted into a live, operating system, but for safety reasons it is recommended that all units in the system be disabled first.

In addition to N+M redundancy, the ideal diode prevents power from flowing into the unit during normal operation. This ensures that power cannot circulate between multiple units when the outputs are in parallel. The digital communications ensures the load is shared evenly (-P ordering option).

Configuration Cables

Configuration cables are necessary for paralleling. They provide the following features:

- Synchronized start up, shut down, and fault recovery
- Digital communication for load sharing
- Up to 32 units in parallel.

The table below lists configuration cables for systems of 2-5 units. Contact the factory for configuration cables that support more than five units in parallel.

Configuration Cables for Paralleling	
2 Units Parallel, 3'	SYN-9341
3 units parallel, 6'	SYN-9343
4 units parallel, 9'	SYN-9344
5 units parallel, 12'	SYN-9345

On/Off control – Parallel Systems

When several units are connected in parallel, any “on” front panel switch actuation will cause all outputs to turn on at once. In addition, the “remote-on” rear panel signal can be used for a coordinated start. Any “off” front panel switch actuation will cause that specific unit be turned off. All other units will continue to deliver power, assuming the load can be supported with one less unit. In addition, the “remote-on” or “remote-off” rear panel signal inputs may be utilized to enable and disable one specific unit.

For coordinated shutdown, the user must send “SYSTEM DISABLE” over RS-232. See Section V of the Owner’s guide for details on the RS-232 interface. See the UPS User Commands document for more information on the “SYSTEM DISABLE” command.

Control Cable Connections

There are two high-density (three-row) DB15 connectors located on the rear panel of the MPC:

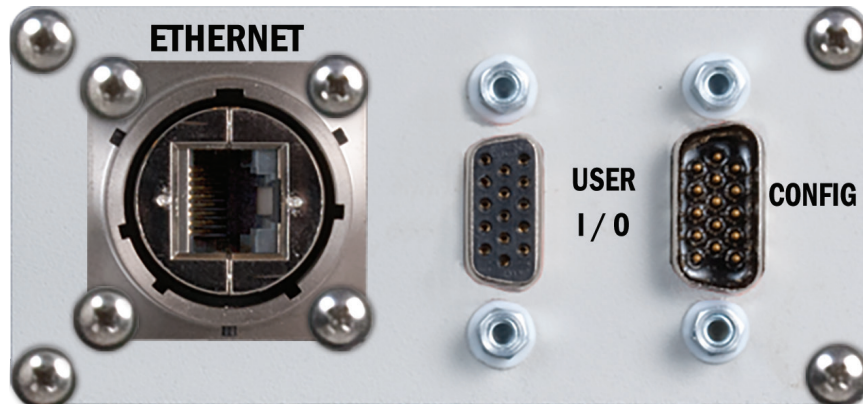

The User I/O female DB15 connector on the left is for a connection to a host/system computer so that it can control the MPC and receive information regarding the status of the MPC.

The Configuration male DB15 connector on the right is used to connect multiple MPCs in parallel. See Section IV for details.

The designation/location of the pins for the User I/O female high-density DB15 connector is shown below:

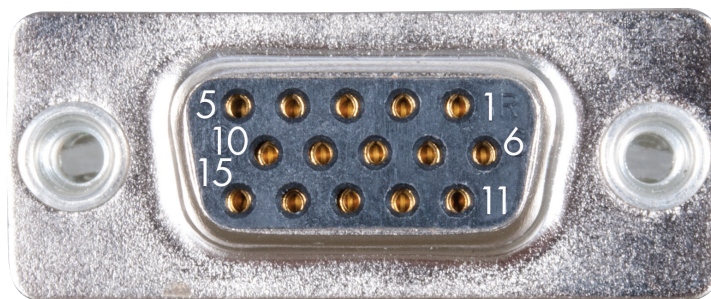

Internal User I/O Circuits

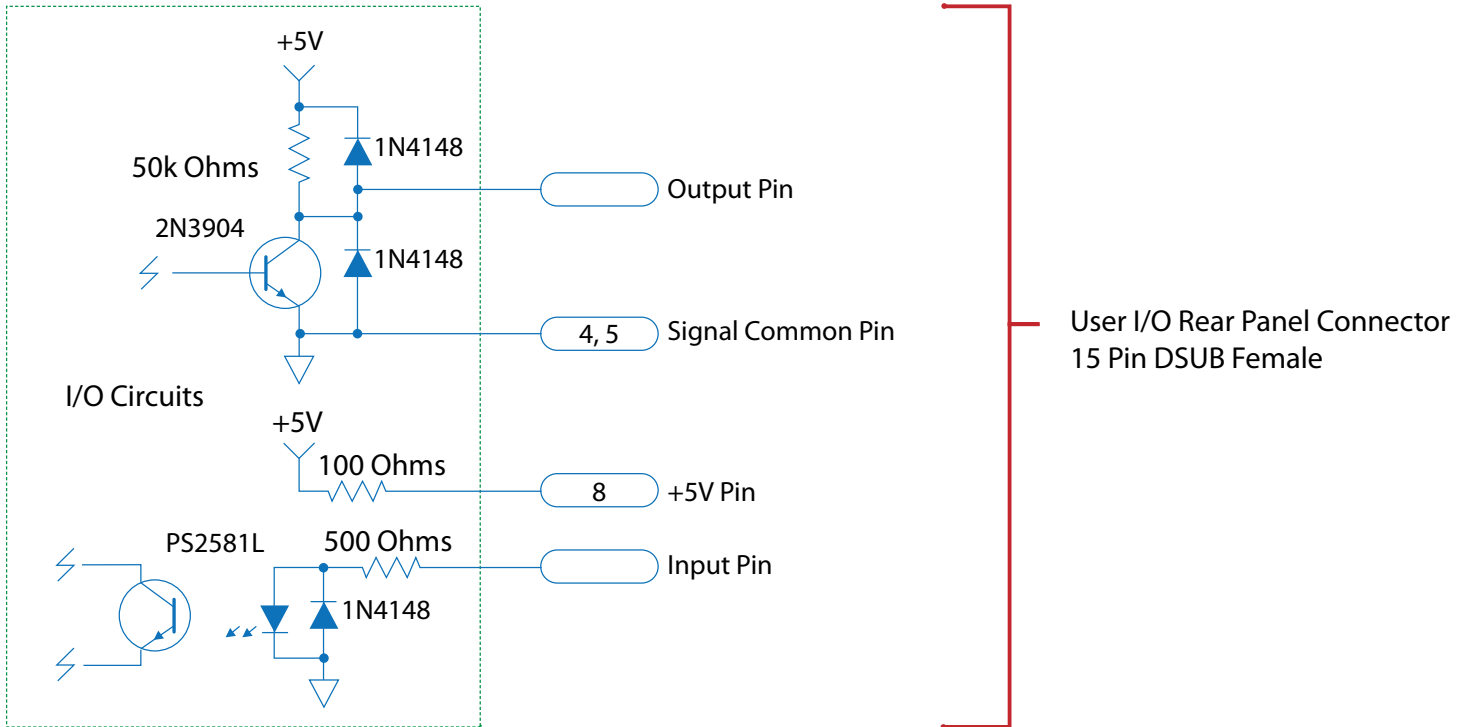

Remote On/Off Switch Connections

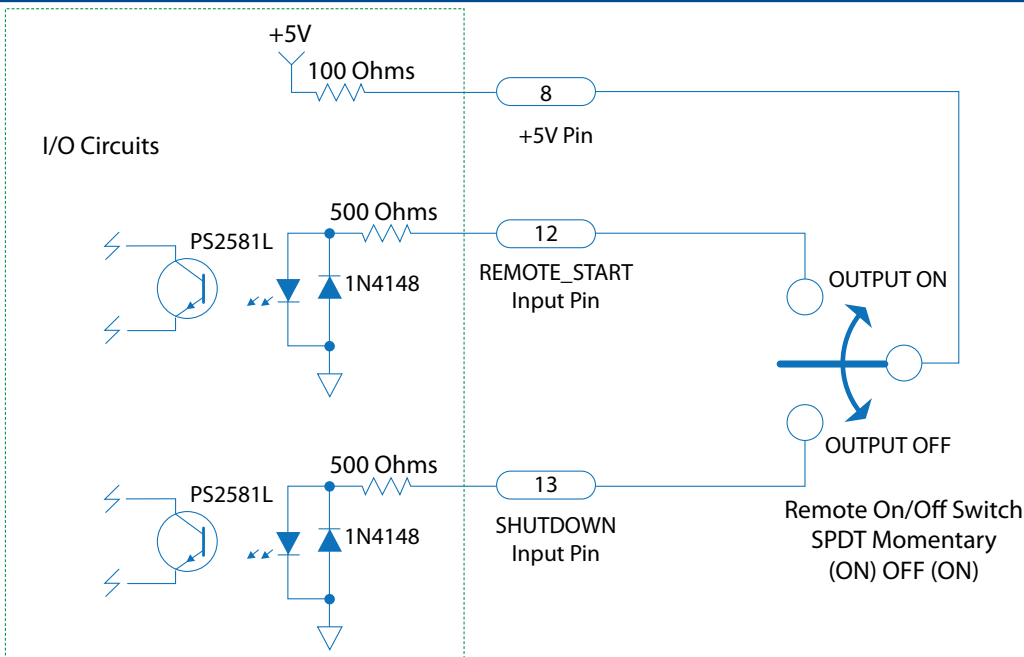

Note: A 2PDT or 3PDT switch may be substituted for single control of 2 or 3 MPC machines, respectively.

Digital Input/Output Control Signals

There are 2 input and 5 output digital signals available on the User I/O female high-density DB15 connector. The pin assignments and functions of these digital I/O signals are as follows:

Signal	Pin Number	Function
+5 V	8	Bias voltage with minimal current drive usable as a pull-up voltage for the open collector output signals (100Ω source resistance)
GND	4 and 5	Ground reference for all digital inputs and outputs
$\overline{\text{ACIN_GOOD}}$	7	Open collector* output where “low” indicates AC Input voltage is within range
$\overline{\text{OUT_OK}}$	14	Open collector* output where “low” indicates DC Output voltage is within range
$\overline{\text{OVER_TEMP}}$	15	Open collector* output where “low” indicates that the MPC is at or above its maximum temperature
REMOTE_START	12	Drive this line “high” with $\geq 5\text{mA}$ to enable the MPC outputs
SHUTDOWN	13	Drive this line “high” with $\geq 5\text{mA}$ to disable the MPC outputs

*with an internal 50 kΩ Pull-up Resistor to 5 V and ESD Protection Diodes.

RS232 Serial Interface

The same User I/O female high-density DB15 connector also provides for an RS232 interface between the MPC and the host/system computer. The interface has a 115.2k baud with eight data bits, no parity bit and one stop bit. The pin assignments and functions for this RS232 interface are as follows:

Signal	Pin Number	Function
GND	4 and 5	Ground reference for RX and TX signals
RX	3	RS232 DCE/MPC Device Receive signal
TX	2	RS232 DCE/MPC Device Transmit signal

The RS232 port provides readback of MPC’s state, as well as the configuration and control of the MPC’s operation. The port can be used from a standard terminal interface, or from a custom computer application.

Readback information that is available:

- AC Input Voltage
- AC Input Current
- AC Input Frequency
- DC Input Voltage
- DC Output Power
- External Switch Input Status
- Fan RPM
- Internal Temperatures

Parameters that are controllable through the interface:

- Output enable / disable
- Fan diagnostics
- Alarm enable / disable

For a detailed description of the terminal interface see the SynQor website at:
https://www.SynQor.com/UPS/documents/UPS_User_Commands.pdf

Ethernet Interface

The Ethernet interface provides a web page based user interface for monitoring and control of the MPC. The user can configure email alerts for MPC alarm conditions. The interface also exposes an SNMP interface compliant to RFC-1628.

The Ethernet interface supports 10BASE-T and 100BASE-T standards. It utilizes a standard RJ-45 connector, also allowing a metallic sealable circular military outer housing. The interface supports auto-negotiation, polarity correction, and Auto-MDIX (detection and use of straight through or cross-over cables).

IP address assignment can be done via DHCP or user entry of a static address. The interface also supports a direct connection between the MPC and a host computer by including a DHCP server internal to the MPC.

For a detailed description of the Ethernet port and SNMP implementation see the SynQor website.
https://www.synqor.com/UPS/documents/UPS_Ethernet_SNMP_UG.pdf

Fans

The fans on the rear panel have sealed bearings that do not require any maintenance. Fan assemblies are user replaceable with kits available from SynQor. Please contact the SynQor factory for obtaining fan replacement kits.

Cleaning

The MPC-1250 unit has a sealed chamber for its electronics that is weather-proof. Only the fans on the rear panel are exposed to the environment, and these fans are also weather-proof. The unit can therefore be cleaned without concern of getting liquids inside the chamber. **NOTE**, however, that if the cables have been removed from the connectors the connectors should have their covers installed. If they are not, then care should be taken to not get excess liquid on the connector terminals. **ALSO NOTE** that care should be taken to not get excess liquid on the switch of the AC BREAKER on the back panel.

Cleaning should be done either with soap and water or with an Isopropyl alcohol and water mixture. A soft cloth should be used.

Do not immerse the unit in water to clean it.

Fault Conditions

The SynQor MPC has no user-serviceable parts within it (other than the fans). If it has an internal malfunction only a factory trained personnel should attempt to repair it.

There are, however, several external conditions that could cause the MPC to not operate as desired. These external conditions can likely be corrected by the user.

The 10 LEDs on the front panel are the best and first place to look to determine what might be wrong with the MPC. The table on the next several pages is therefore organized by what these LEDs indicate, and for each indication there is a listing of what might possibly be wrong.

The front panel LED array is shown below. The designations of the 10 LEDs in this array are used in the following table.

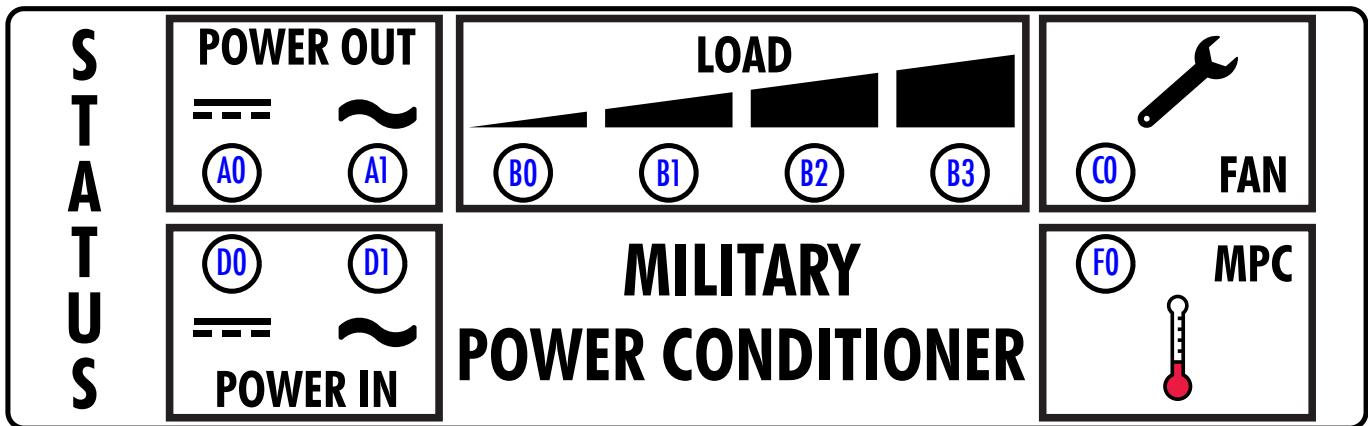

LED	Indication	Possible Problem(s)
D1: AC INPUT Power LED	LED is OFF	<ul style="list-style-type: none"> •The AC INPUT power source is not turned on. •The AC INPUT cable is not connected or it is wired wrong. •The AC Breaker on the rear panel is OFF. •The AC INPUT voltage is either too low or too high.
	LED is a STEADY GREEN and not a PULSING GREEN. MPC is instead running off the optional DC INPUT	<ul style="list-style-type: none"> •The AC INPUT voltage is within its proper range but the MPC is not selecting it for its source of power. •The AC INPUT voltage and the total load power may exceed the power derating curves given earlier in this Guide. •The AC INPUT cable may have too much series resistance. Thicker wire should be used.
D0: DC INPUT Power LED	LED is OFF	<ul style="list-style-type: none"> •The optional DC INPUT is not available on this unit. •The DC INPUT power source is not turned on. •The DC INPUT cable is not connected or it is wired wrong. •The DC INPUT cable is connected to the DC source with the wrong polarity. •The DC INPUT voltage is either too low or too high •The DC INPUT cable may have too much series resistance. Thicker wire should be used.
A0: DC OUTPUT Power LED	LED is OFF	<ul style="list-style-type: none"> •The MPC is OFF and needs to be turned ON.
	LED is AMBER	<ul style="list-style-type: none"> •The DC Output load is higher than 1250 W. •The DC Output is shorted within the cable or a load. •Some other source of power is connected to the DC OUTPUT.
	LED is RED	<ul style="list-style-type: none"> •The MPC has been turned OFF, but due to a malfunction within the MPC it is still running and providing an DC OUTPUT voltage. •Some other source of voltage is connected to the DC OUTPUT and is powering it when the MPC is not
B0 – B3: LOAD POWER LEDs	B3 is BLINKING RED	<ul style="list-style-type: none"> •Total MPC load power is greater than or approaching 1250 W. The MPC may still be delivering its specified output voltage because the load power is not high enough to trigger the power limit circuitry.
	B0 – B3 are all OFF	<ul style="list-style-type: none"> •No power is being delivered to the load. •The MPC is OFF and needs to be turned ON. •The loads or output cables are not connected. •The loads are all turned off. •The loads are simply not drawing any appreciable power at the time.

LED	Indication	Possible Problem(s)
F0: MPC Cooling System LED	LED is BLINKING GREEN	<ul style="list-style-type: none"> Indicates that the fans are running at 67% of their rated speed. There is no problem.
	LED is AMBER	<ul style="list-style-type: none"> Indicates that the fans are running at 100% of their rated speed. There is no problem, but the unit is operating at a high ambient temperature and a high load combination.
	LED is RED	<ul style="list-style-type: none"> Fans are running at 110% of rated speed to keep the unit cool. The maximum recommended temperature may be exceeded, but the fans are keeping things cool enough to avoid triggering the over-temperature shut-down circuitry.
C0: Fan Service Required LED	LED is AMBER	<ul style="list-style-type: none"> One or both fans have recently had degraded performance but seem to be ok now. The MPC is running a diagnostic test.
	LED is RED	<ul style="list-style-type: none"> One or both fans presently have degraded performance, even if they are running, and service is recommended at the earliest convenient time. Ensure that the fan blades are not obstructed from turning
Audible Alarm: (pattern repeats every 5 seconds)	Two tones	<ul style="list-style-type: none"> The total MPC load power is above 1250 W. Loads should be reduced if this condition persists.
	Three tones	<ul style="list-style-type: none"> The DC OUTPUT has experienced either a short circuit or a load having a start-up surge current characteristic that the MPC could not start. The DC OUTPUT is in hiccup mode. To reset the DC OUTPUT, turn the unit OFF. Clear the short circuit fault on the end-use equipment. Turn the unit back ON.

Two other conditions should be mentioned:

- The fans are off when the MPC is running

It is normal for the fans to be off, even if the MPC is running and delivering power to the load, as long as the temperature of the MPC is low enough. If the Fan Service Required LED (C0) is green, both of the fans are OK, even if they are not running.

- The MPC does not turn off when the ON/OFF switch is pushed down

When the ON/OFF switch on the front panel is pushed down, the MPC does not respond to this signal for approximately 1 second. This is done to ensure that the MPC is not accidentally turned off. If the user does not hold the ON/OFF switch in the OFF position for a full second before releasing it, the MPC will not turn off.

Other possible situations that are the result of external issues that a user could likely correct are related to:

- Loads that draw a large surge of current at start-up

Some DC loads draw a very large amount of current when an input voltage is first applied to them. This might happen when the MPC is first turned on if the load is already connected to the MPC. Or it may happen when the load itself is turned on and/or connected to the DC OUTPUT of a MPC that is already running. Common examples of such loads are motors and incandescent lights, but some electronic equipment can also display this characteristic.

Several problems could arise with such a load:

- The MPC fails to start the load:

The SynQor MPC is designed to overcome the problem of surge currents with some loads.

If there is more than one load of the DC OUTPUT that displays this start-up surge characteristic, and the MPC is not capable of starting with all of them connected and switched on, it may be possible to switch on each load in turn.

- A newly started load disturbs the existing MPC loads.

A common problem can occur when the MPC is running and powering one or more loads connected to its DC OUTPUT, and then an additional load of the DC OUTPUT is turned on. If this newly started load draws a large surge current at start-up, it can cause the current limit of the MPC's DC OUTPUT to be triggered, and the DC OUTPUT voltage will then drop. This drop could cause the existing loads to be disturbed. Furthermore, if the voltage drops far enough, the MPC will turn off its DC OUTPUT and initiate a new start-up sequence (after 4 seconds). This latter action would cause the power flow to the existing loads to be interrupted.

If this disruption of existing loads is a problem, then the solution is to make sure the loads that display this start-up surge characteristic are all started first, or that all loads are started at the same time.

- Cable wire resistance is too high:

As mentioned in the section “Power Cables Wire Size”, the resistance of a power cable’s wires gives a voltage drop from the upstream to the downstream end of the cable. This voltage drop, if large enough, will cause the either MPC to determine that the voltage at its AC INPUT or its DC INPUT is below its minimum specified value, even though the corresponding voltage at the source of AC or DC power is within the specified range.

This problem is particularly possible for the DC INPUT, since the DC INPUT current is so high (as much as 65 A at full power) and the DC INPUT voltage is so low (as low as 22 V).

The phenomenon that may be displayed is the following.

- Assume the AC INPUT source is not present, but the DC INPUT source is.
- The MPC, before it turns on, does not draw any power or current from the DC INPUT, and therefore the voltage drop across the DC INPUT cable is zero.
- The MPC sees that the voltage at the DC INPUT is within its specified range, and enables its outputs.
- As the load then draws power, the MPC begins to draw current from the DC INPUT cable. This current causes a voltage drop to appear across the cable.
- If the voltage at the DC source is close to, but still above, its 22 V minimum, but the voltage drop across the cable is large enough for the voltage at the DC INPUT of the MPC to fall below 22 V, then the MPC will determine that the DC INPUT is out of range and will shutdown.
- Since the MPC no longer draws current from the DC INPUT, the voltage drop across the DC INPUT cable goes back to zero volts.
- After a while, the MPC decides the DC INPUT voltage is back within its proper range, and begins to draw a current from the DC INPUT.
- The cycle above repeats itself for a total of three times, at which point the MPC stops trying to draw power from the DC INPUT for one minute. After this one minute another set of 3 cycles are repeated, followed by another stop for one minute, and so on.

This same problem can also occur for the AC INPUT if the voltage at the AC source is close to the specified 80 Vrms minimum limit. In this case the MPC will try ten times before stopping for a one minute interval.

The solution to this problem is to make sure that the cable has wires of sufficient diameter, or “gauge” for the length of the cable. The longer the cable, the bigger diameter the wire should have.

See the section “Power Cable Wire Size” for recommended cable wire sizes.

MPC **MILITARY FIELD-GRADE**

MILITARY POWER CONDITIONER

Operator's Guide

MPC-1250 DC Output Series



Made in USA

006-0007207

07/28/2025

REV H

SynQor[®]
Advancing The Power Curve[®]