

MINV **MILITARY FIELD-GRADE**

MILITARY GRADE POWER INVERTER

Operator's Guide *MINV-4000-270 Series*



MINV-4000-270

N+M REDUNDANCY
(optional)

SynQor
Advancing The Power Curve®

Table of Contents

SECTION I

WARNINGS

<i>Hazardous Voltages</i>	1
<i>Hazardous Energies</i>	2
<i>Protection from the Environment</i>	2
<i>User Serviceable Parts</i>	2

SECTION II

GENERAL PRODUCT INFORMATION

<i>Product Description</i>	3
<i>Product Topology</i>	4
<i>Part Numbering Scheme and Options</i>	5
<i>Product Specifications</i>	6
<i>Technical Specifications</i>	7
<i>IU Mechanical Diagram</i>	8
<i>Efficiency</i>	9
<i>Total Output Power</i>	9
<i>Temperature Derating</i>	10
<i>Power Cable Wiring Diagram</i>	10

SECTION III

OPERATION

<i>Set-Up</i>	11
<i>Start-Up</i>	11
<i>Shut-Down</i>	11
<i>Power Cable Connections</i>	12
<i>Programming The Output</i>	12
<i>Cooling System</i>	13
<i>Front Panel Indicators</i>	14
<i>Audible alarm</i>	16
<i>Operating Environment</i>	17

SECTION IV

MULTIPLE UNIT CONFIGURATION

<i>General Considerations</i>	18
<i>Expanded Paralleling -F Option</i>	19
<i>Redundant Paralleling -R Option</i>	20
<i>Possible configurations of the AC OUTPUTs</i>	21
<i>Parallel Connection of the AC Outputs</i>	24
<i>Series Split-Phase Connection of AC Outputs</i>	26
<i>Series 3-Phase Connection of AC Outputs</i>	27
<i>Connecting DC Inputs</i>	28
<i>Wiring Caution</i>	28

SECTION V

CONTROL INTERFACE DETAILS

<i>Control Cable Connections</i>	29
<i>Internal User I/O Circuits</i>	30
<i>Remote On/Off Switch Connections</i>	30
<i>Digital Input/Output Control Signals</i>	31
<i>Ethernet Interface</i>	31
<i>RS-232 Serial Interface</i>	32

SECTION VI

MAINTENANCE

<i>Fans</i>	33
<i>Cleaning</i>	33

SECTION VII

TROUBLE-SHOOTING GUIDE

<i>Fault Conditions</i>	34
-------------------------------	----

Hazardous Voltages

The **INPUT AND OUTPUT POWER** connectors and cables of the SynQor MINV-4000-270 may have voltages that are unsafe. **INJURY OR DEATH ON CONTACT** may result. Appropriate safety precautions should be taken. All connections should be made in accordance with **LOCAL ELECTRICAL CODES**.

- The **CHASSIS** should be connected to earth or system ground with Ground Stud on the rear panel, see mechanical diagrams.
- For the **DC input** cable and connector:
 - Do not assume that a hazardous voltage is not present at the terminals of the DC input connector, even if the MINV appears to be “OFF”.
 - Do not make contact with the terminals of the DC input connector.
 - Always connect the cable to the MINV before it is connected to the source of DC power.
 - Always disconnect the DC input cable from the source of DC power before disconnecting it from the MINV.
 - If the DC input cable is connected to the source of DC power and not connected to the MINV, do not contact the exposed terminals of the DC input cable.
 - If custom built cables are used to power the MINV Unit, verify that the custom input cabling has a reliable ground connection and that the ground connection has not been accidentally swapped with a line connection. Connecting the ground wire to a live line could possibly put hazardous voltages across the chassis.
 - Connections between the DC input cable and the source of DC power should not be accessible.
- For the **AC OUTPUT** cable and connector:
 - Do not assume that a hazardous voltage is not present at the terminals of the AC output connector, even if the MINV appears to be “OFF”.
 - Do not make contact with the terminals of the AC output connector.
 - Connect the AC output cable to the MINV before the MINV is turned on.
 - If connection of the load to the AC output cable has exposed conductors, make this connection before connecting the AC output cable to the MINV.
 - Connections between the AC output cable and the AC load should not be accessible.

Hazardous Energies

The **INPUT AND OUTPUT POWER** connectors and cables of the SynQor MINV-4000-270 may be a source of high levels of energy. Do not inappropriately make electrical contact between any terminal of a connector and another, or between any wire of a cable and another, or between any terminal or wire and the MINV Unit's chassis or ground. **DAMAGING ELECTRICAL ARCS** may result. Care should be taken to avoid accidental electrical contacts of this sort. The CHASSIS should be connected to earth or system ground through the Ground Stud on the rear panel, see mechanical diagrams.

Protection from the Environment

The SynQor MINV-4000-270 is a ruggedly built product having its electronics contained in a sealed chamber. It is capable of withstanding harsh levels of mechanical acceleration, shock and vibration, temperature and pressure variations, and exposure to water, salt, sand and dust within the levels specified in the data sheet. **THESE LEVELS SHOULD NOT BE EXCEEDED.**

Do not obstruct the air intake in the front of the MINV or the fan exhausts in the rear panel of the MINV while the MINV is operating.

User Serviceable Parts

MINV-4000-270 fans are user replaceable with kits available from SynQor. Please contact the SynQor factory for obtaining fan replacement kits and instructions (Counter-Rotating Replaceable Fan Module , two piece kit, SYN-9452). The SynQor MINV has no other user serviceable parts inside. **DO NOT REMOVE** the cover of the MINV or any of its connectors. Other than fan assembly replacement, only factory trained personnel should perform unit repairs.

Product Description

SynQor's Military Inverter (MINV) Units are designed for the environmental and demanding electrical conditions of Military/Aerospace applications. The MINV-4000-270 will accept a DC Input with a voltage range of 160-330 Vdc. The unit will deliver a well-conditioned continuous 4000 W/5000 VA, 115/230 Vrms Single-Phase output to the load. The output is surge-rated for 5250 W/6500 VA for transient durations up to 10 seconds. All MINV units are designed and manufactured in SynQor's USA facilities to comply with a significant set of military standards.

A communication/control port is available to permit monitoring and control through a host computer system. Front panel LEDs provide information on the status of the MINV.

The electronic circuitry within the MINV-4000 Series products is designed, qualified and screened according to SynQor's MIL-COTS Standards. It complies with the requirements of MIL-STD-704F and MIL-STD-461F.

The MINV-4000 Series products are designed and manufactured to withstand the harshest environments and use encountered in military applications. The electronic circuitry is contained in a sealed chamber constructed from a die-cast aluminum chassis that is weather-proof and shock-proof. Redundant, water-proof fans on the rear panel draw cooling air over the heat-sink fins below the sealed chamber. Military-grade circular connectors are used, and optional attached connector covers are available for when the cables are not attached. The MINV products comply with a wide range of testing according to MIL-STD-810G.

The SynQor MINV-4000 Series products are designed and manufactured in the U.S.A..

Product Topology

The SynQor MINV-4000 Series products use an isolated topology that provides protection to the load from spikes, noise, surges, brownouts, blackouts, etc. in the input power source. They also provide smoothing of load transients and nonlinear load profiles so that the input power source is not subjected to these disturbances. EMI filters are present at all MINV-4000-270 external inputs and outputs.

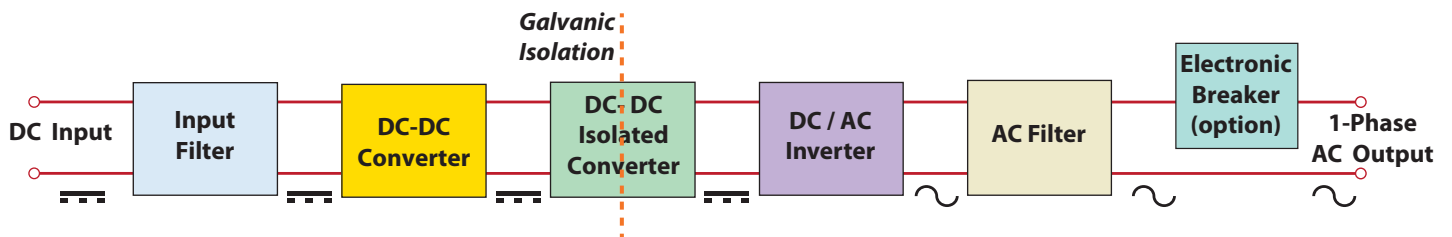

Power flows in the MINV Unit from the DC INPUT through an EMI Filter, to a DC-DC Boost converter. The boost converter provides power smoothing for pulsed loads. The boosted DC power is then passed through an isolated DC-DC converter to create a galvanic isolation layer between the DC input and the DC mid-bus. Bulk energy storage capacitors connected to the mid-bus also smooth imbalances in the power flow. The AC OUTPUT is then created by an inverter that draws power from the isolated DC mid-bus. The inverter provides a pure-sinusoidal output voltage waveform. An AC EMI Line Filter located at the output of the inverter provides clean, well-conditioned continuous output power to the load. An optional electronic breaker can be added to the AC OUTPUT. The breaker is a single-pole hot side only type, that allows for fault-tolerant, glitch-free operation when several MINV Units are connected in parallel.

There is a communication/control port that provides a digital interface to a host computer system.

Part Numbering Scheme and Options

This table shows the part numbering scheme for the full line of SynQor MINV-4000-270 products:

Base Models			
Model Number	Power	Height (W x D x H)	Weight
MINV-4000-1U-270	4000 W 5000 VA	1U (17.00" x 22.42" x 1.73")	33 lbs.

Base Models	Options				
	AC Output Voltage	AC Output Neutral Wire	AC Output Set Point Freq	Output Config	Additional Options
MINV-4000-1U-270-	1 2	G F R	5 6 4	S	-E 00

Options	
AC Output Voltage	1 115 V 2 230 V
AC Output Neutral Wire	G Grounded F Floating* R AC Output Electronic Breaker*
AC Output Set Point Freq	5 50 Hz 6 60 Hz 4 400 Hz
Output Config	S One Single-Phase Output
Additional Options	-E Ethernet/SNMP with Config Loading 00

Not all combinations make valid part numbers, please contact SynQor for availability. See the Product Summary web page for more options.

***Notes:**

Order "F: Floating" option when configuring the AC output for multi-unit combinations of up to 32 units.

Order "R: AC Output Electronic Breaker" option for fault-tolerant, glitch-free parallel systems of up to 32 units with N+M redundancy. The AC output neutral wire will not be connected to the chassis for either the F option or R option.

Example:

MINV-4000-1U-270-1G6S-E00

The MINV-4000 Series of products provide up to 4000 W (5250W transient) of AC Single-Phase output power.

The base model comes in the following form factor:

- A 1U high, 33 lbs. rackmount unit.

The following options that can be specified according to the part numbering scheme shown in the table:

- The AC OUTPUT voltage of the MINV-4000 Series can be 115 Vrms or 230 Vrms.
- The AC OUTPUT can be configured with its neutral wire intentionally grounded to the chassis of the MINV or left floating for shipboard and paralleling applications of up to 32 units.
- The initial set-point frequency of the AC OUTPUT voltage can be 50, 60, or 400 Hz. Regardless of the initial set-point frequency, the actual frequency can be set through the communications/control port to 50, 60, or 400 Hz.

- The Electronic Breaker option adds fault-tolerant, glitch-free multi-unit operation for N+1 or N+M redundancy. This option allows up to 32 units total in Single-Phase, Split-Phase, or 3-Phase systems.
- RS-232 serial port and logic-level I/O communication are included in the standard model. An Ethernet port provides web and SNMP interfaces.

Product Specifications

The next pages show the electrical and mechanical specifications of the MINV-4000 Series of products. Data sheets showing these specifications and other information can be found at the web site <http://www.synqor.com/MINV>.

MINV-4000-1U-270

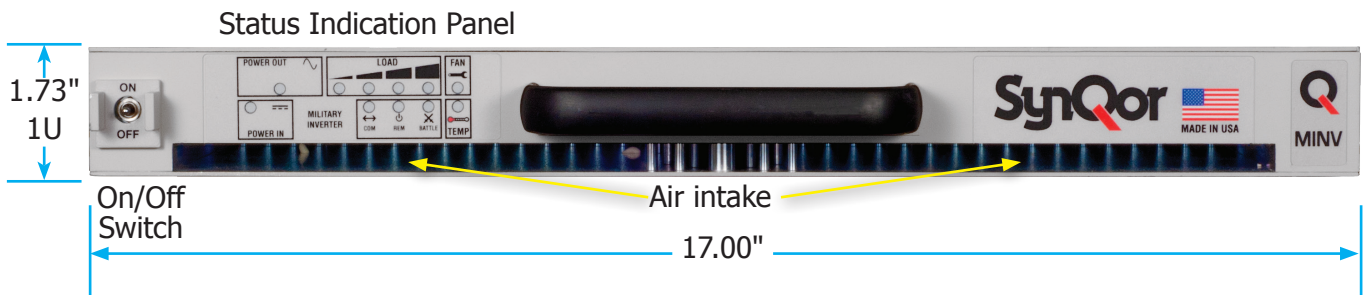

MINV-4000-1U-270

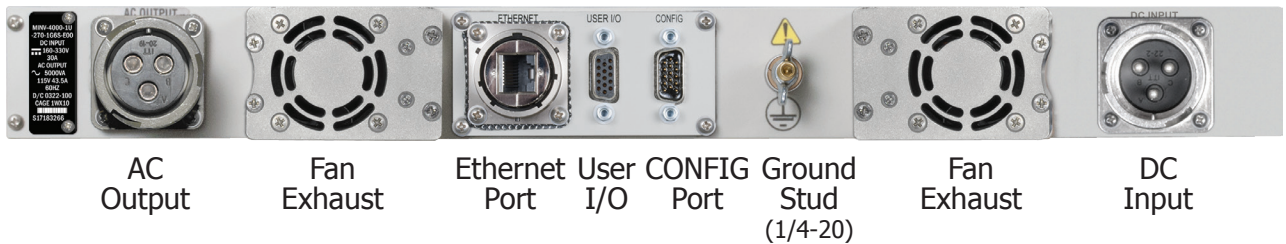

Transit Case Option

Technical Specifications

DC INPUT CHARACTERISTICS

Voltage - Steady State	160 - 330 Vdc
Voltage - 100ms Transient	150 - 350 Vdc
Input Current - Typical	16.6 A (4000 W, 270 V)
Input Current - Maximum	30 A (4000 W, 150 V)
Internal Fuse Rating	40 A Fast Blow
Reverse Polarity Protection	-650 Vdc

AC OUTPUT CHARACTERISTICS

Continuous Output Power	4000 W (5000 VA)
Transient Output Power (15 seconds)	5250 W (6500 VA)
AC Output Waveform	Pure Sinusoidal
Voltage Line-Neutral	115 Vrms \pm 3%
	230 Vrms \pm 3%
Frequency (software selectable)	60 Hz \pm 0.5%
	50 Hz \pm 0.5%
	400 Hz \pm 0.5%
Output Voltage Total Harmonic Distortion	<2%
Load Power Factor	0-1.0 (leading or lagging)
Efficiency	90% (4000 W load)
	88% (2000 W load)

Single-Phase Output

Steady State Load Current	43.5 Arms (115 Vrms)
	21.7 Arms (230 Vrms)
Transient Load Current (15 seconds)	56.5 Arms (115 Vrms)
	28.3 Arms (230 Vrms)
Peak Load Current (Min. Shutdown Threshold)	104 Apk (115 Vrms)
	52 Apk (230 Vrms)

Specifications subject to change without notice.

ENVIRONMENTAL CHARACTERISTICS MIL-STD-810G

Temperature Methods 501.5, 502.5

Operating Ambient Temperature	
Full Rated Power	-40 °C to +55 °C
Reduced Power	+55 °C to +70 °C
Storage Temperature	-40 °C to +70 °C

Altitude Method 500.5

Operating	0 - 18,000 ft
Non-operating	0 - 40,000 ft

Environmental Tests

Shock/Drop	Method 516.6, Procedures 1, 4, 6
Temperature Shock	Method 503.5, Procedure 1
Vibration	Method 514.6, CAT 5, 7, 8, 9, 24
Fungus	Method 508.6
Salt Fog	Method 509.5
Sand and Dust	Method 510.5, Procedures 1, 2
Rain	Method 506.5 Procedure 1
Humidity	Method 507.5 Procedure 2
Mechanical Vibrations of Shipboard Equipment	Method 528 Procedure 1

RELIABILITY CHARACTERISTICS MIL-HDBK-217F

MTBF: 450 kHrs	MIL-217F Ground Benign, Ta=25 °C
----------------	----------------------------------

INTERFACE STD FOR AIRCRAFT SYSTEMS MIL-STD-704

270 Volts DC System

115 V 1-Phase Output Power per Table I, Table II, Table III
(Order F / R Option to Float Output)

ELECTROMAGNETIC CAPABILITY MIL-STD-461F

CE101-2	30 Hz - 10 kHz
CE102	10 kHz - 10 MHz
CS101	30 Hz - 150 kHz
CS106	Pulse Transients
CS114 (Curve #5)	10 kHz - 200 MHz
CS115	Impulse Excitation
CS116	10 kHz - 100 MHz
RE101 (Navy Limit)	30 Hz - 100 kHz
RE102 (Navy Topside Limit)	10 kHz - 1 GHz

MECHANICAL CHARACTERISTICS

Chassis Size	17.00" W x 22.42" D x 1.73" H (1U)
Case Material	Aluminum
Weight	33 lbs.

DC Input Connector

DC Input Connector	CA3102E20-19PXA34
--------------------	-------------------

AC Output Connectors

115V Single Phase	CB2-20-19SXA34-FM
230V Single Phase	CB2-20-19SXA34-FM

I/O Ports

Configuration I/O Port	HD DB15 Male
User I/O Port	HD DB15 Female
Ethernet Port	Amphenol RJF22N00, Code B

Cooling Exhaust Fans

Sound Pressure Level (SPL)	64 dB(A)
Air Flow	0.92(m ³ /min) 32.5 CFM

Two fans in system; above specs are for each fan separately.

1U Mechanical Diagram

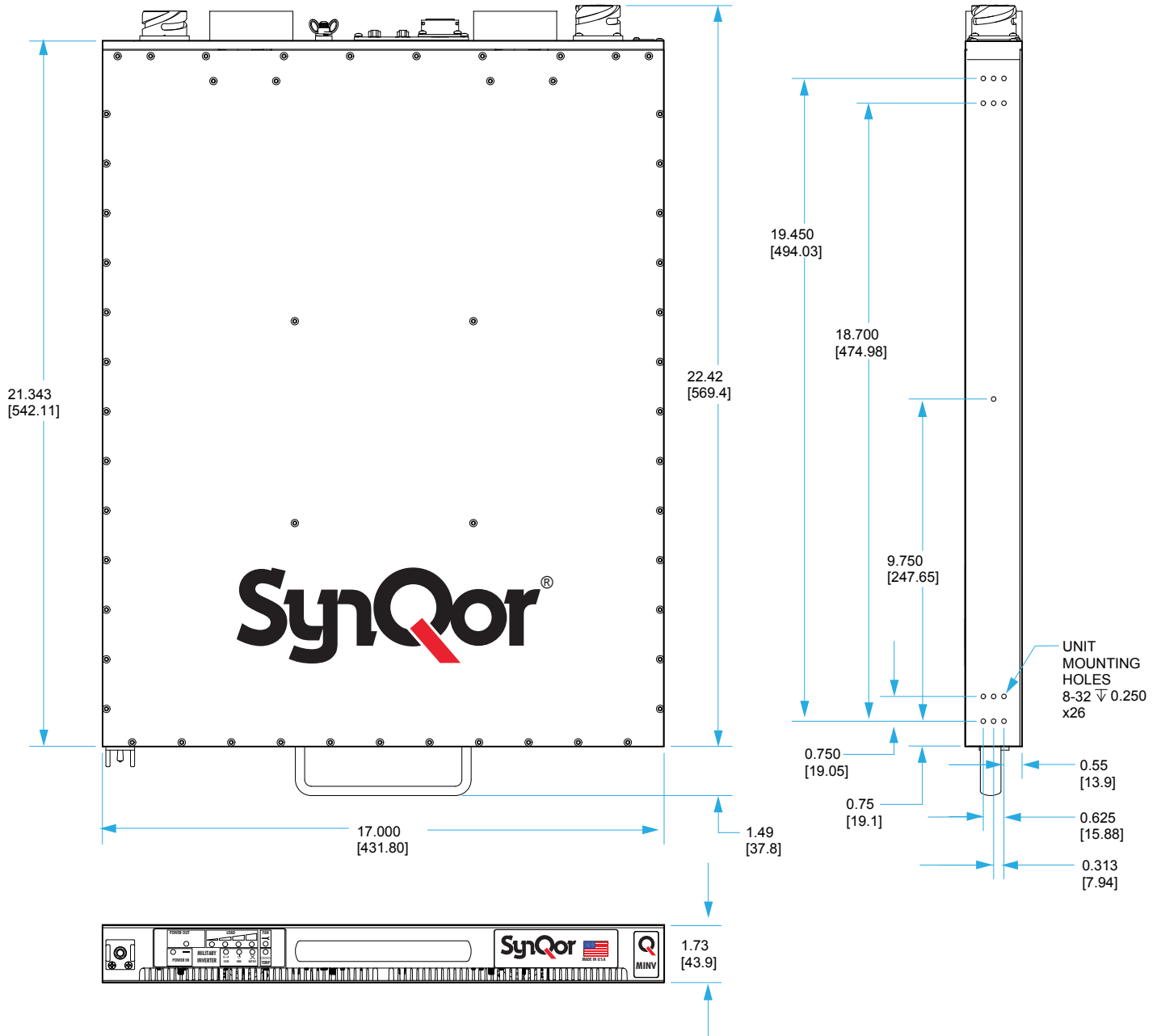

Efficiency

Figure 1 shows the typical efficiency with which the MINV-4000-270 unit delivers power to its AC OUTPUT load from 60 Hz:

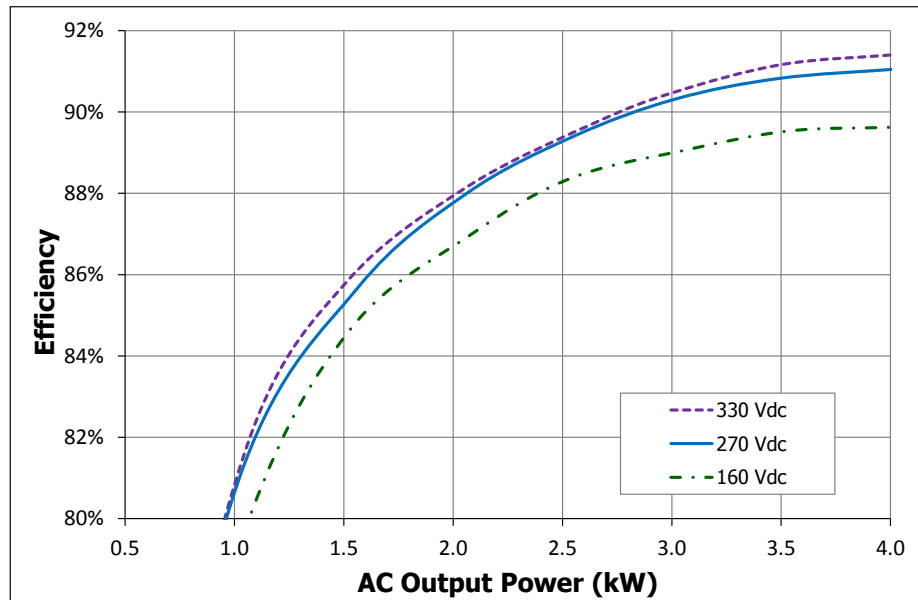

Figure 1

Total Output Power

The total output power for the MINV-4000-270 is rated at 4000 W/5000 VA (Surge-rated to 5250 W/6500 VA for transient durations up to 10 seconds) for an ambient temperature as high as 55°C (131°F).

Temperature Derating

The maximum steady-state MINV-4000-270 output power as a function of ambient air temperature and DC input voltage is shown below in Figure 2. (See Section IV).

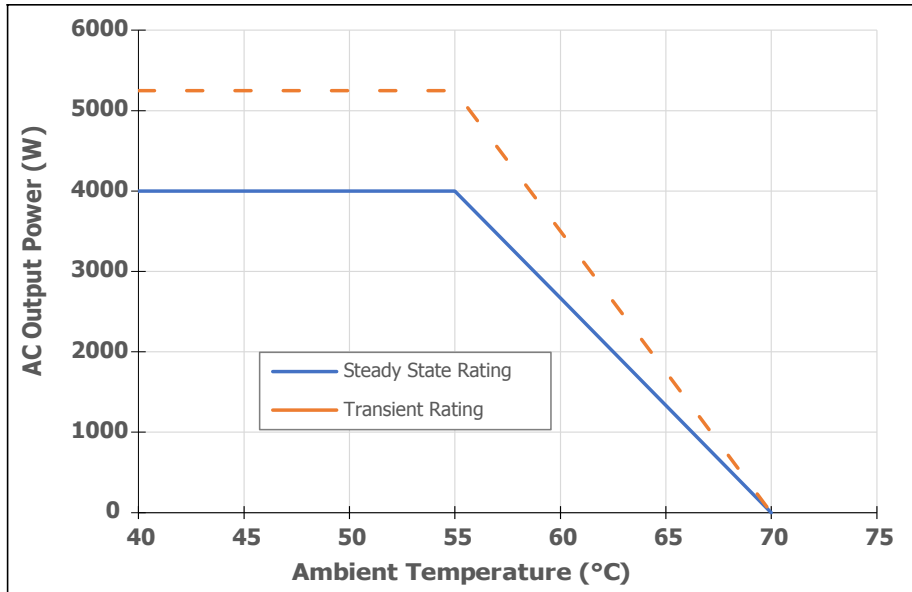
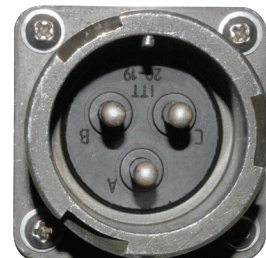
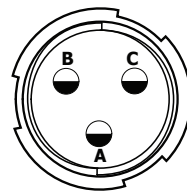

Figure 2: Output Power vs. Ambient Temperature

Power Cable Wiring Diagram

Looking at the rear panel, the MINV-4000-270 connector terminals have the following functions and locations:

DC Input	
Pin	Function
A	Ground
B	Vin +
C	Vin -



Warning: Pin D should never be connected to a line Voltage

AC OUTPUT	
Pin	Function
A	Line 1
B	Line 2
C	Ground

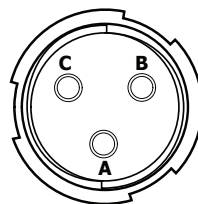

Set-Up

The recommended procedure for setting up the MINV-4000-270 is the following:

- Connect the ground wire to the ground stud on the rear panel of the MINV.
- Connect the AC OUTPUT cables, first to the MINV and then to the load.
- Connect the USER I/O cables.
- Check that pin A in the input connector is not connected to Vin + or Vin -. On input cables provided by SynQor, pin A (Earth Ground) is connected to the green color wire.
- Ensure the DC power source is off.
- Connect the INPUT cables, first to the MINV and then to the DC source.
- Turn on the source (if it has an up-stream breaker).

Start-Up

- VERIFY that all connections to the MINV-4000-270 are correct.
- If the DC source is present and within specifications, a POWER IN LEDs on the front panel will light up green.
- Momentarily push the “ON/OFF” switch on the front panel of the MINV upward. The switch can then be released and it will return to its normal (neutral) position.
- The MINV will immediately enable its outputs (assuming there is no fault condition). The color of the POWER OUT LED(s) on the front panel will change to green. The LOAD LEDs on the front panel will indicate the amount of power being delivered to the load.

Shut-Down

- Shut down the equipment connected to the MINV-4000-270.
- Push the “ON/OFF” switch on the front panel of the MINV downward and hold it in this position for 1 second (or more). The switch can then be released to return to its normal position.
- The MINV will disable its outputs.

Power Cable Connections

For safety reasons, the input and output power cables should be connected to the MINV-4000-270 before the source of DC power is turned on (see **Section I: Warnings** and the **SET-UP** section above). Similarly, one should first turn “OFF” the MINV and the source of input power before any power cables are disconnected from the MINV.

ALSO NOTE that when the MINV-4000-270 is turned “ON” and delivering power to a load, and then another piece of equipment is connected to the same output, it is possible that this connection will momentarily disrupt the quality of the MINV’s output voltage. For instance, consider the case where the AC OUTPUT power cable has a terminal strip that allows several loads to be connected to it. If the MINV is turned “ON” and delivering power to several of these loads and then another load is connected to the terminal strip, it is possible that this new load will momentarily draw a large surge of current as it starts up. If this happens, the output of the MINV could reach its maximum current limit, and the MINV will reduce its output voltage to keep the current from getting any larger. This reduction in voltage will be corrected once the new load reaches its normal mode of operation, but in the meantime the reduction of the MINV’s output voltage might cause one or more of the other loads to malfunction. Whether or not this will be a problem depends on the characteristics of the various loads.

Programming The Output

The MINV-4000-270 allows the user to adjust the output frequency. The output frequency can be set to 50, 60 and 400 Hz via both the serial and web interfaces. The MINV output frequency cannot be programmed using the SNMP interface.

See the MINV Ethernet and SNMP guide for details on updating the output frequency using the web page. See the MINV User Commands document for details on updating the frequency using the RS-232 interface.

https://www.synqor.com/document-viewer?document=MINV_User_Commands.pdf

https://www.synqor.com/document-viewer?document=MINV_Ethernet-SNMP_User_Guide.pdf

Cooling System

The SynQor MINV-4000 Series products are cooled by fans that draw air into the intake on the front panel and exhaust it out the two fan ports on the rear panel. Care should be taken to ensure there is no obstruction to this airflow, either at the front intake or the rear exhaust ports. Similarly, care should be taken to avoid obstructing the fan blades.

The speed of the cooling fans is automatically controlled to provide adequate cooling while extending the life of the fan bearings. Under low ambient temperature and/or low output power the fans will be driven at a low speed.

If the ambient temperature is low enough (for the level of power being delivered to the load), the fans may not be on. This is not a malfunction. It is done to preserve the life of the fans. If the fans are “OFF”, check the Fan Service Required LED on the front panel of the battery pack. If it is GREEN, the fans are functioning properly and simply not needed under the present conditions.

The fans are weather-proof and water-proof.

The MINV-4000-270 has two fans to provide redundancy for these exposed, moving components. With only a single operating fan the MINV is still able to deliver 100% rated power at an ambient temperature of 25°C, 85% rated power at 40°C, and 70% rated power at 55°C.

Note: The environmentally sealed chassis of the MINV also serves as a heatsink for internal components. As such, it is normal for the outside surface of the chassis to be hot to the touch.

Front Panel Indicators

To indicate the status of the MINV there are 11 LEDs on the front panel. These indicators are described in this section.

LEDs

Each MINV has up to 11 LEDs, as shown below, that indicate the status of the operation of the MINV:

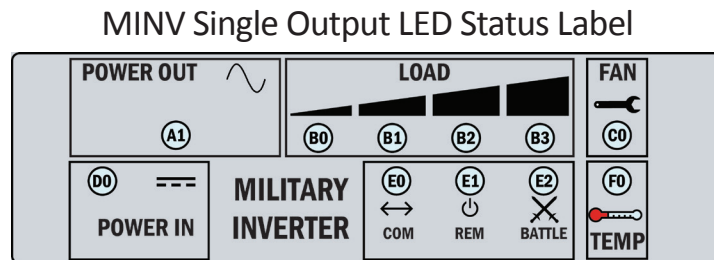

• Power-In Indicator (LED in position D0)

The LED D0 indicates the status of the DC INPUT, according to the table below:

LED Appearance	Description	Indication
	Green	<i>Input is Ready to Provide Load Power</i>
	Amber	<i>Input is Not within Range</i>
	Red	<i>Input is Not Present</i>
	Off	<i>MINV is Off</i>





• Power-Out Indicator (LED in position A1)

The LED in position A1 indicates the status of the AC OUTPUT, according to the table below

LED Appearance	Description	Indication
	Green	<i>MINV is On and the Output Voltage is Within Range</i>
	Amber	<i>MINV is On but the Output Voltage is Out of Range</i>
	Red	<i>MINV is Off and the Output Voltage is Within Range</i>
	Off	<i>MINV is Off</i>



• **Load Power Indicators (LEDs in positions B0 – B3)**

The LEDs in positions B0 through B3 indicate the total output power of the MINV according to the table:

LED Appearance	Description	Indication
	<i>B0 Dimmed Green; B1-B3 Off</i>	<i>Total Load Power <25%</i>
	<i>B0 Green; B1 Dimmed Green; B2-B3 Off</i>	<i>Total Load Power <50%</i>
	<i>B0, B1 Green; B2 Dimmed Green; B3 Off</i>	<i>Total Load Power <75%</i>
	<i>B0, B1, B2 Green; B3 Dimmed Green</i>	<i>Total Load Power <100%</i>
	<i>B0; B1; B2 Green; B3 Blinking Red</i>	<i>Total Load Power ≥100%</i>





• **MINV Fan Service Required Indicator (LED in position C0)**

The LED in position C0 indicates whether the two cooling fans in the rear panel of the MINV are OK or if their performance is degraded, according to the table below:

LED Appearance	Description	Indication
	Green	<i>Both Fans are OK</i>
	Amber	<i>One or Both Fans Have Recently Had Degraded Performance and Diagnostic Tests are Being Performed</i>
	Red	<i>One or Both Fans Presently Have Degraded Performance</i>



• **MINV Cooling System Indicator (LED in position F0)**

The LED in position F0 indicates the temperature and status of the cooling system for the MINV according to the table below:

LED Appearance	Description	Indication
	Green	<i>Moderate MINV Temperature (Fans Running at 25%)</i>
	Blinking Green	<i>Warm MINV Temperature (Fans Running at 50%)</i>
	Amber	<i>Elevated MINV Temperature (Fans Running at 75%)</i>
	Red	<i>Maximum MINV Temperature (Fans Running at 100%)</i>
	Blinking Red	<i>Over Temperature Warning (Fans Running at 100%)</i>

• **Control Status (LED in position E0, E1, E2)**

The LED in position E0, E1 or E2 indicates whether RS232 or Ethernet Port, Remote Enable/Shutdown or Battle Short are active:

LED Appearance	Description	Indication
	Green	<i>E0: RS232 active or Ethernet Port Active, E1: Remote Enable Active</i>
	Blinking Red	<i>E2: Battle Short Mode Active, Temperature Shutdowns Removed</i>
	Red	<i>E1: Remote Shutdown Active</i>

Audible alarm

For critical situations a pattern of audible tones will be repeated every 5 seconds, according to the table below. This audible alarm can be **silenced** by holding the ON/OFF switch on the front panel in the “UP” position while the MINV is operating and its output is running, or in the “DOWN” position while in Standby Mode, until a chirp is heard. A new alarm condition will cause the audible alarm to be reactivated. Contact Factory for instructions on how to permanently silence the alarm.

Number of Tones in Pattern	Indication
One	<i>Input Voltage is Lower than Minimum Operating Level</i>
Two	<i>Load Power is greater than or Approaching 100% Rated Power</i>
Three	<i>Fault Appears on the AC Output MINV Must be Turned Off and Back On to Reset Fault</i>
Four	<i>One or More Fans have Encountered a Fault and Require Service</i>

Operating Environment

The SynQor MINV-4000 Series is designed for the extreme environmental conditions of military and aerospace applications. All the electronic circuitry is contained in a sealed, weather-proof, shock-proof chamber constructed of die-cast aluminum. Only the redundant, water-proof cooling fans are exposed to the environment. The Unit will shut down if it is too hot and Battle Mode is not active.

The MINV-4000-270 (with cables connected or connector covers installed) has been qualified to the following requirements of MIL-STD-810G:

MIL-STD-810G Test Method	Name	Procedure	Details
500.5	Low Pressure	I, II and III	<ul style="list-style-type: none"> • 15,000 ft. operating • 40,000 ft. storage
501.5	High Temperature	I and II	<ul style="list-style-type: none"> • +55°C operating • +65°C storage
502.5	Low Temperature	I and II	<ul style="list-style-type: none"> • -20°C operating • -20°C storage
503.5	Temperature Shock	I	<ul style="list-style-type: none"> • 10 cycles; >10°C/minute
506.5	Rain	I	<ul style="list-style-type: none"> • 4" rain/hour • 40 mph wind velocity
507.5	Humidity	NA	<ul style="list-style-type: none"> • >95%
508.6	Fungus	NA	<ul style="list-style-type: none"> • 28 day test
509.5	Salt Fog	NA	<ul style="list-style-type: none"> • 5% salt solution • 2 cycles (24 hr. wet/24 hr. dry)
510.5	Sand and Dust	I and II	<ul style="list-style-type: none"> • 20 mph blowing dust • 40 mph blowing sand
514.6	Vibration	Category 5	<ul style="list-style-type: none"> • 5 Hz (300 RPM) • Loose Cargo
514.6	Vibration	Category 7	<ul style="list-style-type: none"> • General Exposure
514.6	Vibration	Category 8	<ul style="list-style-type: none"> • C-130 Aircraft level
514.6	Vibration	Category 9	<ul style="list-style-type: none"> • General Exposure
514.6	Vibration	Category 24	<ul style="list-style-type: none"> • PSD = 0.04 g²/Hz; 20-2000 Hz • Operating
516.6	Shock	I, IV and VI	<ul style="list-style-type: none"> • 20 g/20 ms; 40 g/11 ms; 75 g/6 ms • 48 inch drop in transit case • 30 degree tilt and drop
528	Mechanical Vibrations of Shipboard Equipment	I	<ul style="list-style-type: none"> • Operating

General Considerations

The MINV-4000-270 supports two different paralleling schemes for the AC output: expanded paralleling and redundant paralleling. Both expanded and redundant paralleling configurations allow, up to 32 MINV Units to be combined to form high power Single-Phase, Split-Phase and 3-Phase systems. The “redundant” paralleling configuration includes an electronic breaker on the hot AC output wire which provides fault-tolerant, glitch-free operation in case a MINV Unit fails in a multi-unit system. The redundant paralleling option allows users to add extra MINV Units to the systems in order to create for N+1 redundancy, or more generally, N+M redundancy.

Expanded vs. Redundant paralleling is determined by the “AC Output Neutral Wire” option in the MINV part number. See the table below. Expanded paralleling units cannot be mixed with redundant parallel units in multi-unit systems.

Ordering Information: Expanded Vs Redundant Parallel		
	AC Output Neutral Wire option	Example PN
Single Unit (no paralleling)	G	MINV-4000-1U-270L1G6S-E00
Expanded Parallel	F	MINV-4000-1U-270L1F6S-E00
Redundant Parallel	R	MINV-4000-1U-270L1R6S-E00

Note: When combining MINV-4000-270 Units into the configurations described in this section, each MINV must internally have the neutral wire of its AC OUTPUT floating, rather than connected to its chassis. This requires that all the MINV units have the “F” option for expanded parallel units and “R” option for redundant parallel units regarding the AC OUTPUT neutral wire connection. Check the MINV part numbers to be sure this is the case before ordering.

Expanded Paralleling -F Option

With expanded paralleling, up to 32 SynQor MINV-4000-270 Units with identical “F” type model numbers can be combined in various ways to achieve:

- Higher output power
- Higher output voltage
- Multiple output phases

A configuration-specific CONFIGURATION cable determines each MINV Unit’s role in an expanded parallel system. These CONFIGURATION cables are available from SynQor, and the proper part number for any configuration is given in the pages that following sections.

Configuration-specific OUTPUT and/or INPUT power cables are also required. These power cables can be assembled by the user following the wiring diagrams shown in the next sections, or using power cables from SynQor that have the appropriate hardwire terminations.

In an expanded parallel system, the AC output will remain “OFF” until one MINV Unit is enabled. This can be done by actuating the front panel switch “ON”, or by sending the appropriate signal over the USER I/O cable. If any MINV Unit in the group is “OFF” it will proceed to turn “ON”. The remaining units in the system will maintain their current active state if already “ON”. If during normal operation any one MINV is unable to deliver output power because it cannot draw power from its DC source, or due to an internal fault, all other MINV units in the group will continue to remain active assuming that the rest of the units can handle the load.

Redundant Paralleling -R Option

The “R” option adds an electronic breaker to the AC output of the MINV-4000-270 to provide fault-tolerant, glitch-free parallel operation. Should one unit experience a fault that could otherwise cause the AC output to collapse, the breaker disconnects the failed unit from the AC bus. This feature allows the remaining units to continue delivering power, provided that the remaining units can support the total load power. This configuration allows users to create N+1 or N+M redundant systems. The redundant parallel units can be arranged to form Single-Phase, Split-Phase, and 3-Phase systems. Systems with multiple phases can also be setup on each phase N+1 or N+M redundant

A failed unit can be removed and replaced while the rest of the units in the system are active. Special consideration must be taken when disconnecting the unit input/output power cables to avoid electric shock or injury. It is strongly recommended that the system DC input be disabled or turned “OFF” before the unit is removed or replaced.

CONFIGURATION cables for two, three, four and five unit and single-phase systems are offered as standard products. See the next sections for further details. Contact the SynQor factory for Single-Phase systems larger than five MINV Units, or for Split-Phase and 3-Phase systems.

Systems created using redundant parallel MINV Units will be fault-tolerant to the following events:

- Complete loss of power to a unit (DC input)
- Hardware failure of the AC output stage of a unit

The enable/disable behavior of systems using redundant paralleling is the same as systems using expanded paralleling; all MINV Units will be enabled if one MINV is enabled. Units can be enabled by actuating the front-panel “ON” switches or by sending the appropriate signal over the USER I/O cable.

Note that sending a “OUTPUT DISABLE” command to a MINV over the serial interface, will cause only that particular MINV unit to be disabled. Other MINV Units in the group will remain active. Sending a “SYSTEM DISABLE” command over the RS-232 interface to any unit in a system; however, will cause all MINV Units in a system to turn “OFF” simultaneously.





For a detailed description of the terminal interface see the SynQor website.

https://www.synqor.com/document-viewer?document=MINV_User_Commands.pdf

Possible configurations of the AC OUTPUTs

Multi-unit Configurations

The chart below shows six possible ways the AC OUTPUTs of multiple SynQor MINV-4000-270 Units can be connected together. Each configuration will be discussed in more detail in the following pages.

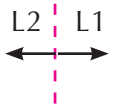
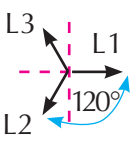
Number of MINV-4000-270 Units	Output Configuration	Phasor Diagram	# of Output Phases	Output Voltage	Output Current per phase	Total Output Power	Configuration Cable
2	Parallel		1	L-N: $1 \times V_{rated}$	$2 \times I_{rated}$	$2 \times P_{rated}$	SYN-9341
3	Parallel		1	L-N: $1 \times V_{rated}$	$3 \times I_{rated}$	$3 \times P_{rated}$	SYN-9343
4	Parallel		1	L-N: $1 \times V_{rated}$	$4 \times I_{rated}$	$4 \times P_{rated}$	SYN-9344
5	Parallel		1	L-N: $1 \times V_{rated}$	$5 \times I_{rated}$	$5 \times P_{rated}$	SYN-9345
2	Series Split-Phase		2	L-N: $1 \times V_{rated}$ L-L: $2 \times V_{rated}$	$1 \times I_{rated}$	$2 \times P_{rated}$	SYN-9613
3	3 Phase-Y		3	L-N: $1 \times V_{rated}$ L-L: $1.73 \times V_{rated}$	$1 \times I_{rated}$	$3 \times P_{rated}$	SYN-9617

Note that the chart above shows the SynQor part number for the CONFIGURATION cable required to build each multi-unit type system.

The “**F**” and “**R**” options allows up to 32 MINV-4000-270 Units to be installed in a single parallel or redundant system. The “**R**” option adds a single pole electronic breaker to the hot wire of the AC OUTPUT. This breaker allows for fault-tolerant, glitch-free operation of up to 32 MINV Units in a redundant N+1 or N+M multi MINV system. Therefore, “**R**” option allows customers to build redundant, Single-phase, Split-phase, and 3-Phase with SynQor’s MINV units. Each of these MINV systems can also be configured to be N+1 or N+M redundant on each phase.

The block diagrams below show a summary of the different system configuration that can be made using units with the “**R**” and “**F**” option. Please note that each multi-unit system requires its own unique system CONFIGURATION (Single-phase, Split-phase, and 3-Phase) cable. Configuration cables are the same for the “**R**” and the “**F**” options. Contact the SynQor factory to purchase the system specific configuration cables. Note that configuration cables for two, three, four and five unit Single-Phase parallel systems are offered as standard products.

Contact the SynQor factory for redundant Split-Phase systems, redundant 3-Phase systems, or Single-Phase systems with more than five units.

Single Phase Output System

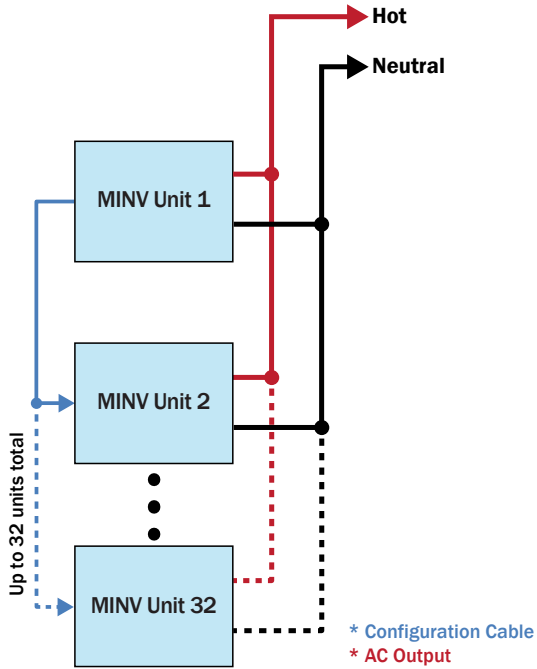

Split Phase Output System

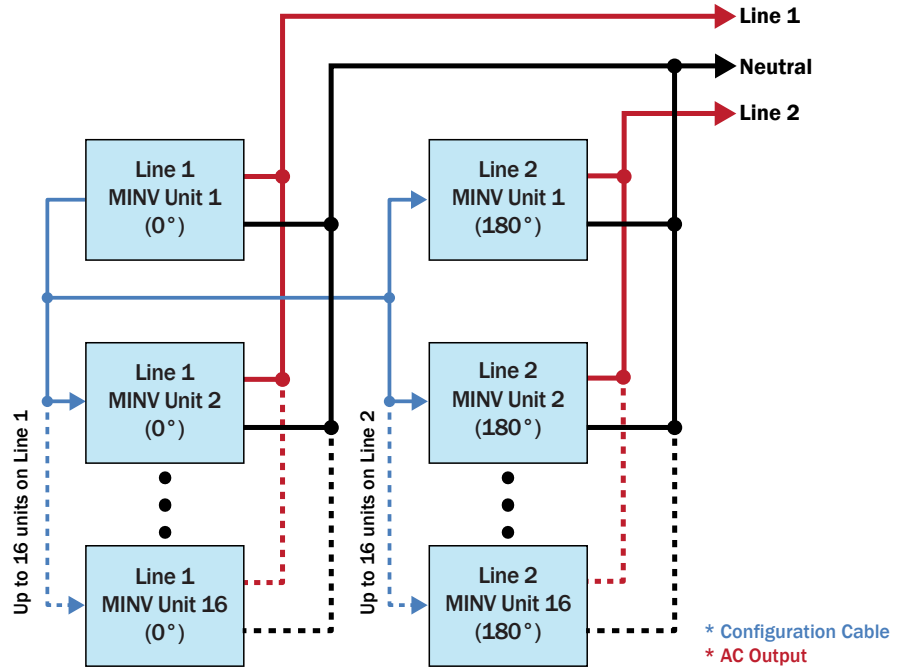

**3-Phase Output System
(Wye - Connection Only)**

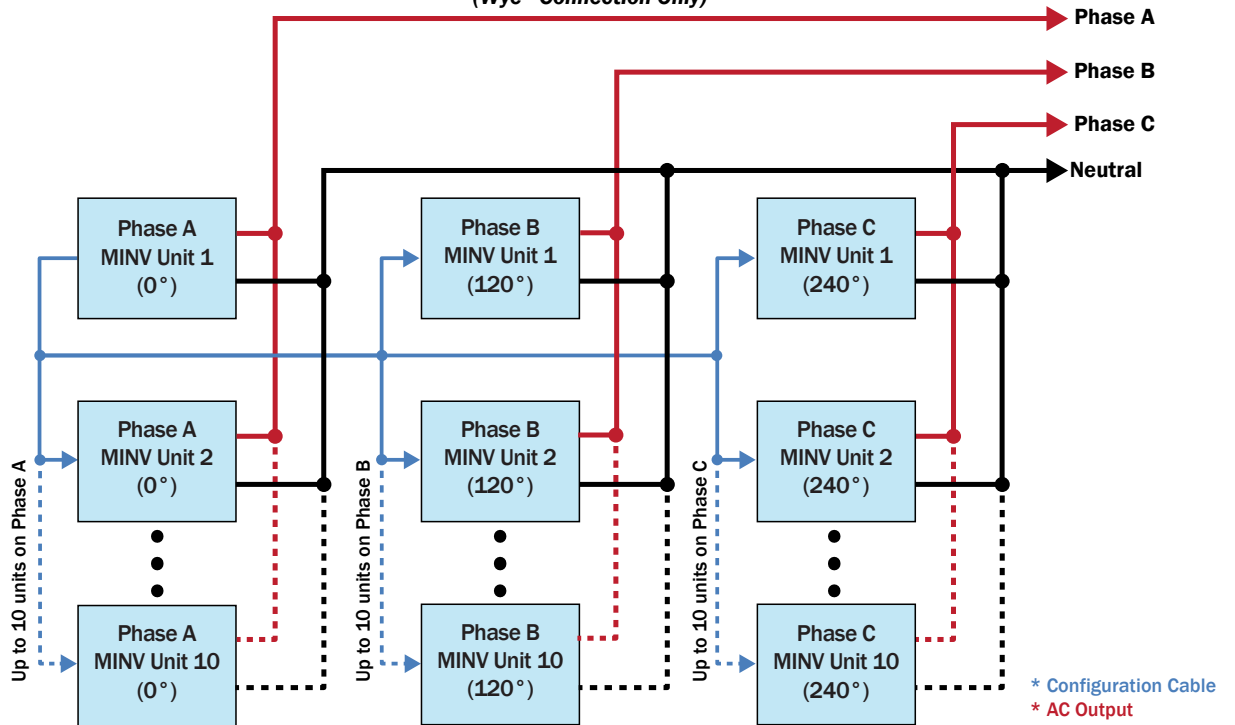

Parallel Connection of the AC Outputs

Multiple MINV-4000-270 Units can have their AC OUTPUTs connected in parallel to deliver to the load the sum of their combined output power and current. This configuration allows redundant parallel units (type “R”) to form N+1 or N+M redundant systems.

Two MINV-4000-270 Units with AC OUTPUTs Paralleled

The following diagram shows how to connect two MINV-4000-270s in an expanded parallel or redundant parallel configuration. The wiring diagram explains how the AC OUTPUT cables and the CONFIGURATION cable need to be connected:

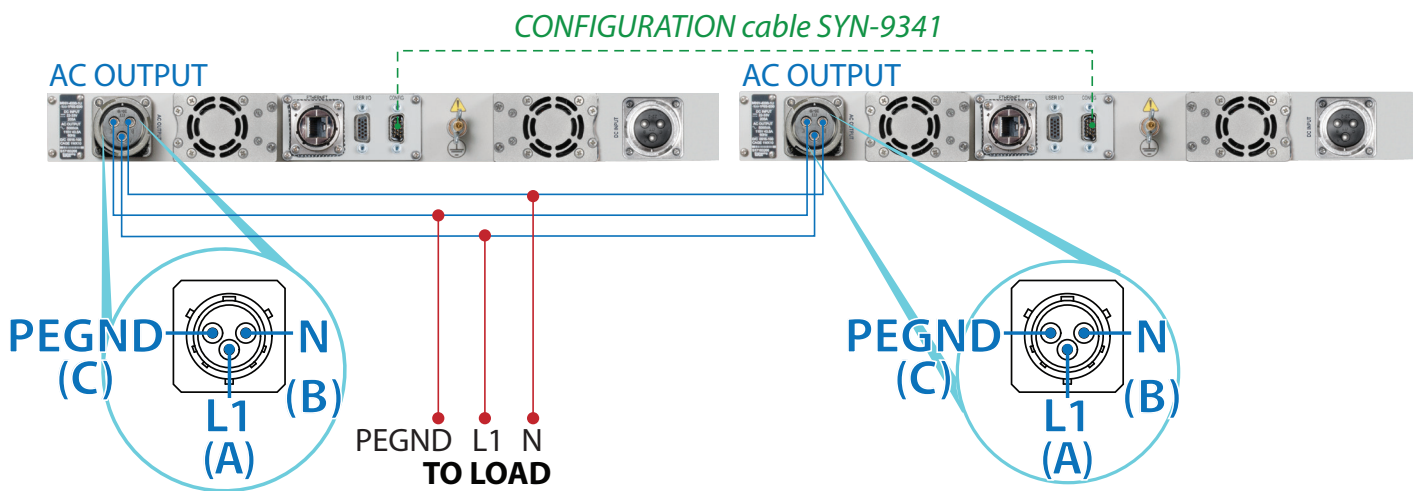

When ordering units for this setup, be sure to select the “F: Floating” or “R: AC Output Electronic Breaker” option for the MINV Units configured in this manner.

If the user is providing its own AC OUTPUT cable, the cable size for the blue and red cable sections shown above, should follow the guide lines in the table below depending on AC OUTPUT voltage of the MINV Units.

MINV-4000-270 AC Output Voltage	Blue Cable Section Minimum Wire Size	Red Cable Section Minimum Wire Size
115 Vac	#8AWG (10 mm ²)	#2AWG (41 mm ²)
230 Vac	#10AWG (6 mm ²)	#6AWG (16 mm ²)

Three MINV-4000-270 units with AC OUTPUTs Paralleled

The following diagram shows how to connect the output of three MINV-4000-270 Units in an expanded parallel or redundant parallel configuration. The wiring diagram explains how the AC OUTPUT cables and the CONFIGURATION cable need to be connected:

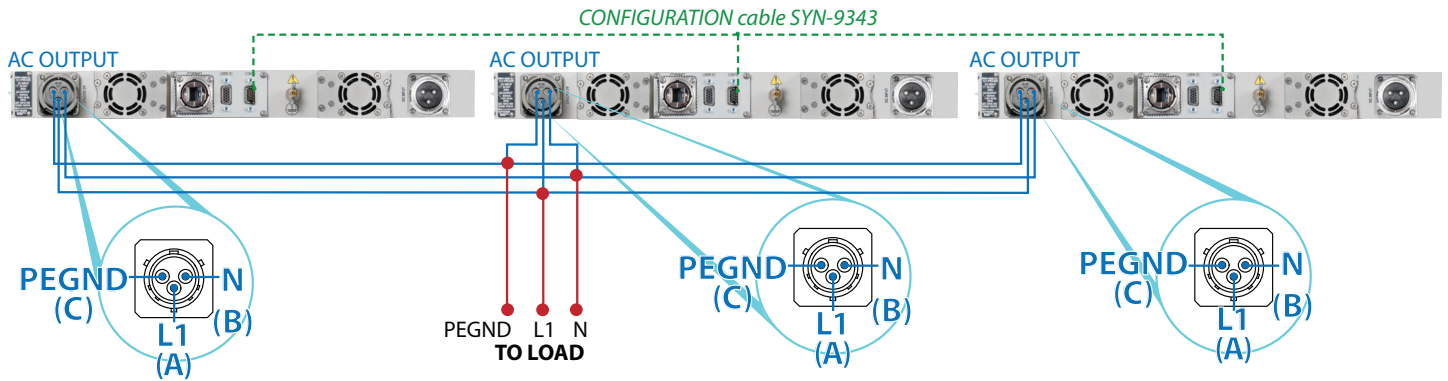

When ordering this type of configuration, make sure you select the “F: Floating” or “R: AC Output Electronic Breaker” option for MINV Units configured in this manner.

If the user is providing its own AC OUTPUT cable, the size of the blue and red cable sections shown above, should follow the guidelines shown in the table below depending on AC OUTPUT voltage of the MINV Units.

MINV-4000-270 AC Output Voltage	Blue Cable Section Minimum Wire Size	Red Cable Section Minimum Wire Size
115 Vac	#8AWG (10 mm ²)	#0AWG (65 mm ²)
230 Vac	#10AWG (6 mm ²)	#4AWG (26 mm ²)

Series Split-Phase Connection of AC Outputs

Two MINV-4000-270 units can double the AC OUTPUT voltage by connecting both units in series. For instance, if each MINV Unit is able to provide 115 Vac output, a series configuration would deliver a 230 Vac output at twice the power level of a single unit. Similarly, if the MINV Units are able to provide 230 Vac output, the series configuration would deliver a 460 Vac output at twice the power level of a single unit.

The center node between the two outputs in the series configuration should be considered the “neutral” wire (Both output Pin Bs of the MINV units are tied together), and therefore kept at a potential close to Protective Earth Ground (PEGND).

The other two AC OUTPUT wires (output Pin A on each MINV Unit) are electrically “hot” (meaning at a high potential relative to the neutral or PEGND). One will be phase-shifted by 180 degrees (one-half cycle) from the other, meaning that when one hot wire is at its positive peak the other is at its negative peak, and vice versa. The voltage between these two hot wires is therefore twice that of either hot wire compared to the neutral wire. This configuration is called “Split-Phase”. When ordering, select the “F: Floating” or “R: AC Output Electronic Breaker” option for the MINV Units.

Contact the SynQor factory for N+1 redundant Split-Phase systems.

The wiring diagram for the AC OUTPUT cables and the CONFIGURATION cable for the Split-Phase configuration is shown below:

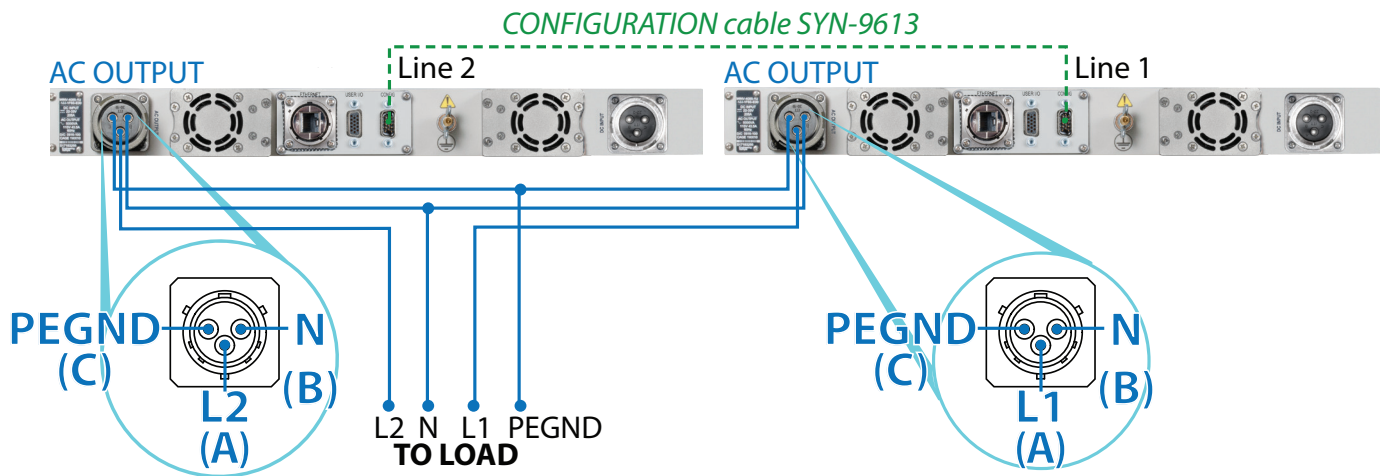

If the user is providing its own AC OUTPUT cable, all the cable sections should have the following minimum wire size, depending on whether the AC OUTPUT of the individual MINV Units is 115 Vac or 230 Vac.

MINV-4000-270 AC Output Voltage	Cable Minimum Wire Size
115 Vac	#8AWG (10 mm ²)
230 Vac	#10AWG (6 mm ²)

Series 3-Phase Connection of AC Outputs

Three expanded or redundant parallel MINV-4000-270 Units can be setup so that their AC OUTPUTs can share a common “neutral” and deliver output voltages that are phased by 120 degrees (one-third cycle) from each other. This configuration delivers a 3-Phase output where the line-to-neutral voltage is the rated voltage of the individual MINV Units (e.g. 115 Vac or 230 Vac line-to-neutral) and the line-to-line voltage is 1.73 times higher (e.g. 200 Vac or 400 Vac line-to-line). When ordering units for this configuration, make sure you select the “F: Floating” or “R: AC Output Electronic Breaker” option for the MINV Units.

Contact the SynQor factory for N+1 redundant 3-Phase systems.

The wiring diagram for the AC OUTPUT cables and the CONFIGURATION cables for the 3-Phase configuration is shown below:

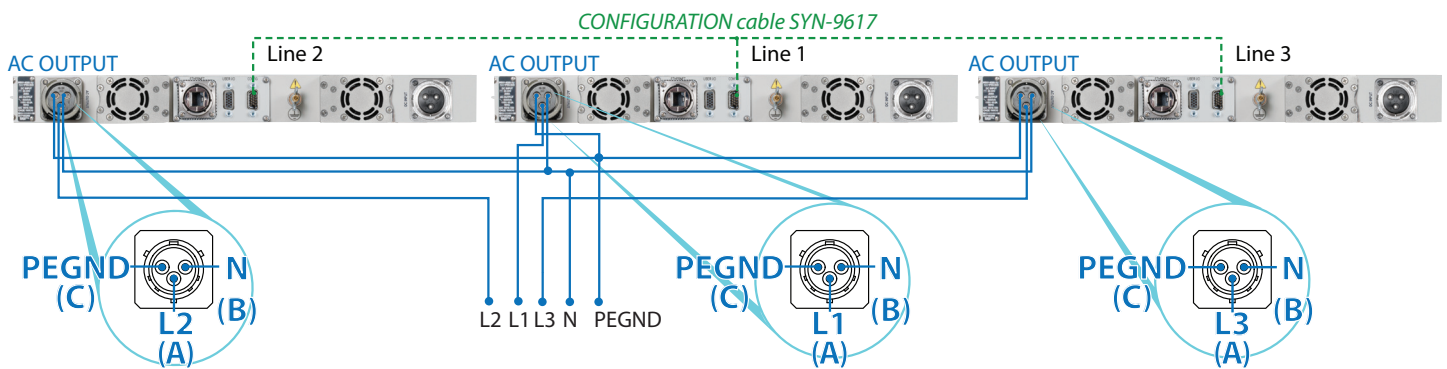

If the user is providing its own AC OUTPUT cable, all the cable sections should have the following minimum wire size, depending on whether the AC OUTPUT of the individual MINV Unit is 115 Vac or 230 Vac.

MINV-4000-270 AC Output Voltage	Cable Minimum Wire Size
115 Vac	#8AWG (10 mm ²)
230 Vac	#10AWG (6 mm ²)

Note that the “neutral” wire of the 3-phase AC OUTPUT (All the output Pin Bs of all the MINV-4000-270 Units are tied together) should be kept at a potential close to Protective Earth Ground (PEGND).

Note: The three connectors of the SYN-9617 CONFIGURATION CABLE are labeled “Line 1”, “Line 2” and “Line 3”. The MINV Unit that receives the “Line 1” connector will have an AC OUTPUT that is phased 120 degrees (one-third cycle) ahead of the MINV Unit that receives the “Line 2” connector, which in turn will have an AC OUTPUT that is phased 120 degrees (one-third cycle) ahead of the MINV Unit that receives the “Line 3” connector. Connecting the three AC OUTPUTs to the three line wires of the AC OUTPUT cable in the proper order may be important for some loads, such as motors.

Multi-Unit AC OUTPUT On/Off Control – Expanded/Redundant Parallel (-F/-R option)

In multi-unit operation, a single front panel “ON” switch actuation, “REMOTE-ON” rear panel signal input, or *OUTPUT ENABLE* serial command will cause all MINV-4000-270 devices to enable their outputs. Redundant parallel units (“R” option) come with a floating neutral wire by default. Any “OFF” front panel switch actuation, “REMOTE-OFF”, or “*OUTPUT DISABLE*” serial command will only disable that specific MINV. Sending the “*SYSTEM DISABLE*” serial command to any MINV system in a multi-unit configuration will cause a coordinated shutdown of all AC OUTPUTs. If any single MINV no longer has a valid input power source (e.g., no DC input), it will shut down while the AC OUTPUTs of the remaining systems stay active.

AC OUTPUT Neutral Grounding

MINV-4000-270 Units combined in multi-unit configurations must have the neutral floating “F” factory option to prevent the possibility of circulation protective earth currents. Redundant parallel units (“R” option) come with a floating neutral wire by default. If a grounded output neutral is required, then the output neutral should be connected to protective earth ground (PEGND) in one spot. The size of the neutral-to-PEGND connecting conductor must be sized to match the largest combined AC output neutral conductor specified in the wiring diagrams.

Connecting DC Inputs

Whether there are two, three or more MINV-4000-270 Units in the multiple-unit configuration, there are several ways that the DC INPUTs can be connected to power sources:

- All units could be connected to the same DC source/panel.
- Units could be connected to different DC sources/panels.

The only requirement is that the MINV Units have input voltages fall within the specified ranges of the DC INPUTs of the individual MINV Units.

Wiring Caution

WARNING: LETHAL HIGH VOLTAGES MAY BE PRESENT ON MINV-4000-270 DC INPUT AND AC OUTPUT CONNECTIONS. ALL DC INPUT AND AC OUTPUT CABLE CONNECTORS MUST BE INSTALLED PRIOR OPERATION. DISCONNECTED CABLE CONNECTORS MAY HAVE VOLTAGES PRESENT FROM ANOTHER UNITS IN A GROUP AND COULD POTENTIALLY BE HARMFUL.

Control Cable Connections

There are two high-density (three-row) DB15 connectors located on the rear panel of the MINV-4000-270:

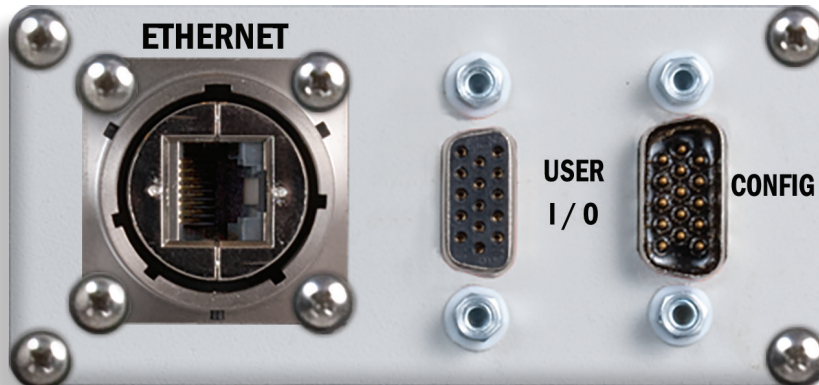

The User I/O female DB15 connector on the left is for an optional connection to a host/system computer so that it can control the MINV and receive information regarding the status of the MINV.

The Configuration male DB15 connector on the right provides for synchronized startup and shutdown operation of multiple interconnected units, using the SYN-9341, SYN-9343, SYN-9344, SYN-9345, SYN-9613 or SYN-9617 cables. See the “Possible configurations of the AC OUTPUTs” on page 21 for supported configurations details.

The designation/location of the pins for the User I/O female high-density DB15 connector are shown below:

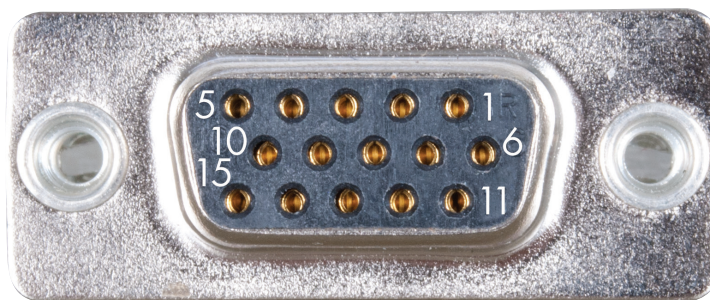

Internal User I/O Circuits

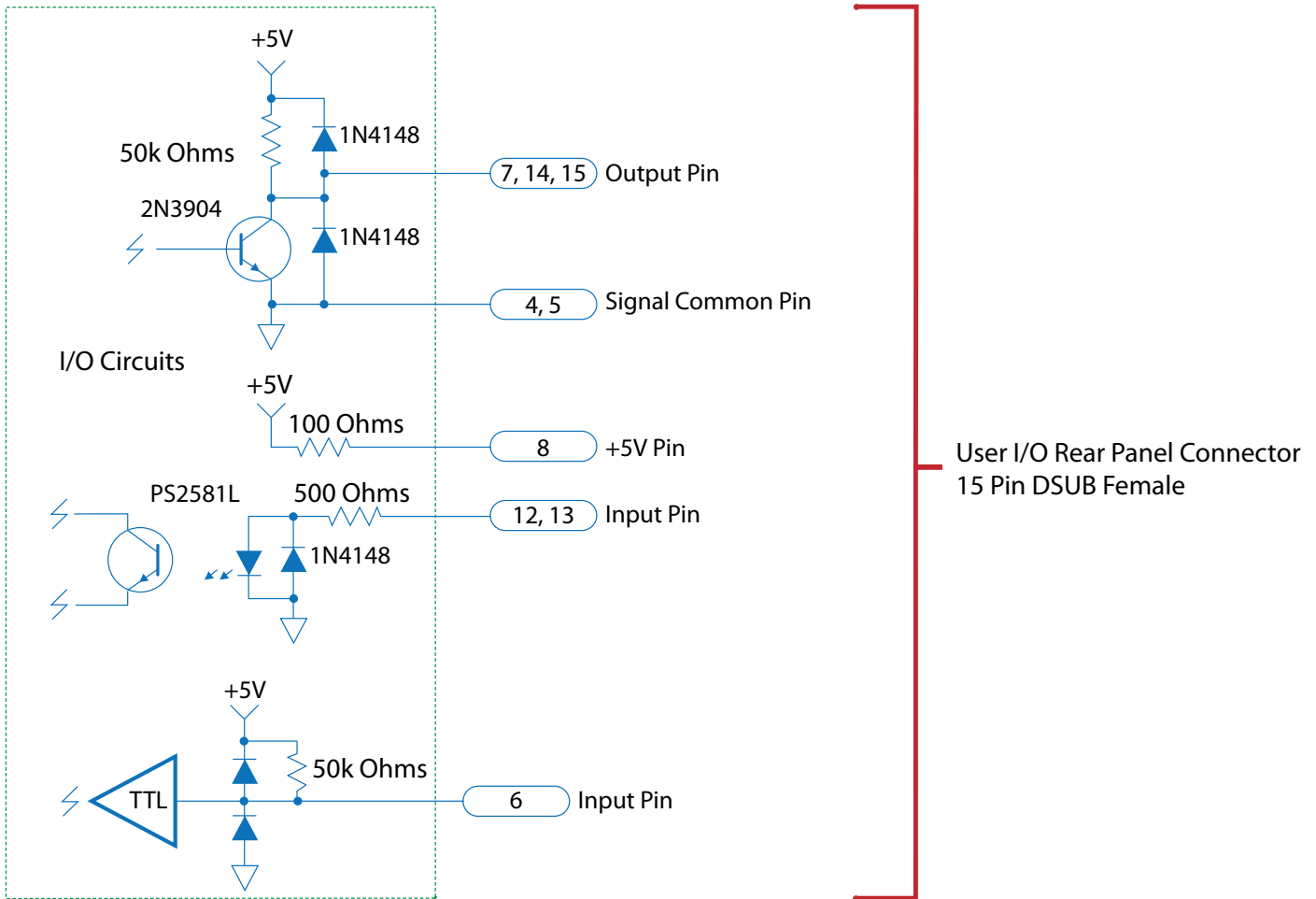

Remote On/Off Switch Connections

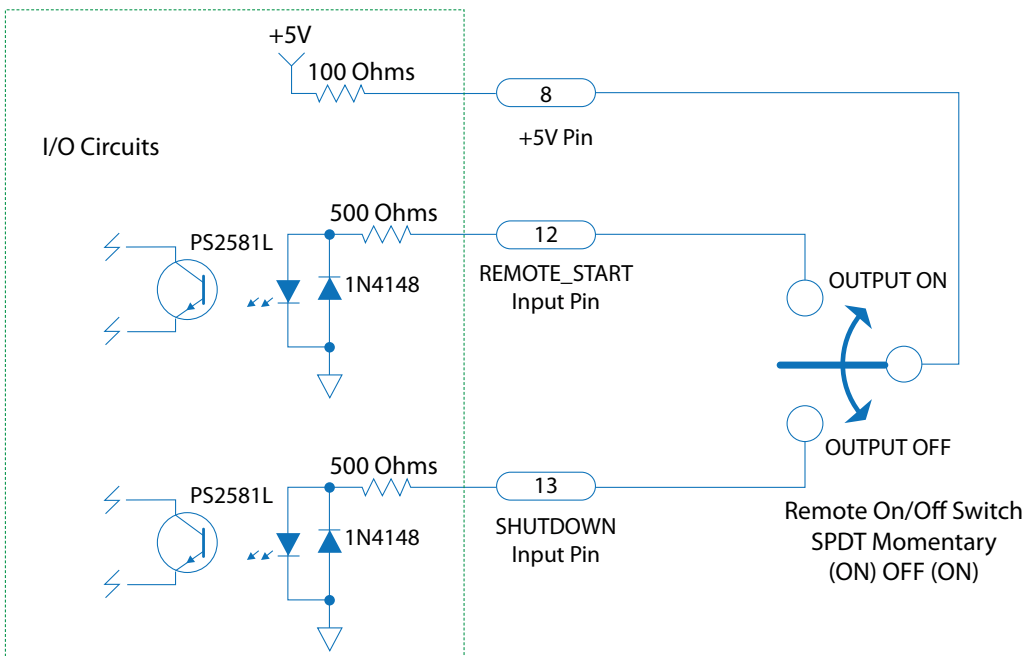

Note: A 2PDT or 3PDT switch may be substituted for single control of 2 or 3 MINV machines, respectively.

Digital Input/Output Control Signals

There are 3 input and 4 output digital signals available on the User I/O female high-density DB15 connector. The pin assignments and functions of these digital I/O signals are as follows:

High Density DB15 Female (15 Pin Connector)

Signal	PIN	Function
TX	2	RS232 DCE Device Transmit
RX	3	RS232 DCE Device Receive
GND	4, 5	Ground reference for all digital inputs and outputs
BATTLE_MODE	6	TTL-Input*, pull "low" to engage Battle Mode to disable internal over temperature protection, has internal pull-up to +5 V
INPUT_GOOD	7	Open collector* output where "low" indicates DC Input voltage is within range
+5 V	8	Vout with minimal current drive usable as a pull-up voltage for open collector output signals. Load must be < 35 mA
REMOTE_START	12	Drive this line to +5 V with ≥ 5 mA to enable MINV output
SHUTDOWN	13	Drive this line to +5 V with ≥ 5 mA to disable MINV output
OUT_OK	14	Open collector* output where "low" indicates AC Output voltage is within range
OVER_TEMP	15	Open collector* output where "low" indicates that the MINV is at or above its maximum temperature

*With an internal 50 k Pull-up Resistor to 5 V and ESD Protection Diodes

Battle Mode disables internal over-temperature shutdown limits in the MINV-4000-270 hardware. Battle Mode is indicated with a flashing red light in panel position E2. This mode can be commanded by pulling low on to I/O Port Pin 6, or via serial command "BS ON".

Ethernet Interface

The Ethernet interface provides a web page based user interface for monitoring and control of the MINV-4000-270. The user can use this interface to set the output frequency. The Ethernet interface also provides a RFC-1628 compliant remote SNMP monitoring interface for the unit.

The Ethernet interface supports 10BASE-T and 100BASE-T standards. It utilizes a standard RJ-45 connector, also allowing a metallic sealable circular military outer housing. The interface supports auto-negotiation, polarity correction, and Auto-MDIX (detection and use of straight through or cross-over cables).

IP address assignment can be configured to be acquired by the unit automatically via DHCP or set up through a static address entry via the web interface. The Ethernet interface also provides a local DHCP server that allows direct MINV to host computer connections.

For a detailed description of the Ethernet port and SNMP implementation see the SynQor website at: https://www.synqor.com/document-viewer?document=MINV_Ethernet-SNMP_User_Guide.pdf

RS-232 Serial Interface

The female high-density DB15 User I/O connector also provides for an RS-232 interface between the MINV-4000-270 and the host/system computer. The interface has a 115.2 kbaud with eight data bits, no parity bit and one stop bit. The pin assignments and functions for this RS-232 interface are as follows:

Signal	Pin Number	Function
GND	4 and 5	Ground reference for RX and TX signals
RX	3	RS-232 DCE/MINV-4000-270 Device Receive signal
TX	2	RS-232 DCE/MINV-4000-270 Device Transmit signal

The RS-232 port provides read back of Unit's state, as well as the configuration and control of the MINV's operation. The port can be used from a standard terminal interface, or from a custom computer application. For MINV-4000 Units, this port can be used to program the output voltage characteristics.

Readback information that is available:

- AC Output Voltage
- AC Output Power
- Battle Mode
- On/Off Synchronization
- Internal Temperatures
- External Switch Input Status
- AC Output Current
- AC Output Frequency
- Fan diagnostics
- Output enable / disable
- Total Output Power
- Fan RPM

Parameters that are controllable through the interface:

- On/Off Synchronization
- Battle Mode
- Output enable / disable
- AC Output Frequency
- Alarm enable / disable
- Fan Diagnostics

For a detailed description of the terminal interface see the SynQor website.

https://www.synqor.com/document-viewer?document=MINV_User_Commands.pdf

https://www.synqor.com/document-viewer?document=MINV_Ethernet-SNMP_User_Guide.pdf

Fans

The fans on the rear panel have sealed bearings that do not require any maintenance. Fan assemblies are user replaceable with kits available from SynQor. Please contact the SynQor factory for obtaining fan replacement kits (Counter-Rotating Replaceable Fan Module SYN-9452).

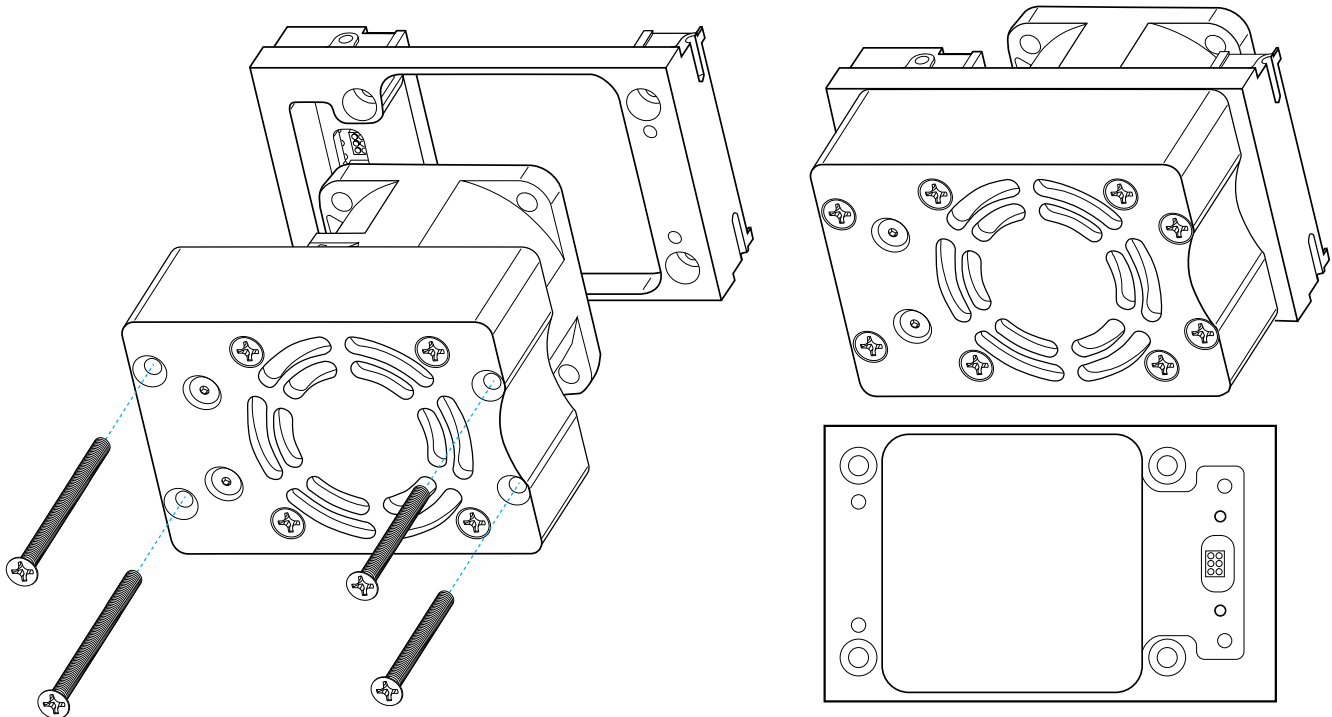

Cleaning

The MINV-4000-270 Unit has a sealed chamber for its electronics that is weather-proof. Only the fans on the rear panel are exposed to the environment, and these fans are also weather-proof. The Unit can therefore be cleaned without concern of getting liquids inside the chamber. **NOTE**, however, that if the cables have been removed from the unit then the unit connectors should have their covers installed to protect the connector from damage, contamination or corrosion. If connectors are not protected, then care should be taken to prevent physical or liquid damage to the connector terminals. **ALSO NOTE**, care should be taken to not get excess liquid on the AC BREAKER switch in the back panel.

Cleaning should be done either with soap and water or with an Isopropyl alcohol and water mixture. A soft cloth should be used.

Do not immerse the Unit in water to clean it.

Rust corrosion in connectors could be an issue.

Fault Conditions

The SynQor MINV has no user-serviceable parts within it. If it has an internal malfunction only factory trained personnel should attempt to repair it.

There are, however, several external conditions that could cause the MINV to not operate as desired. These external conditions can likely be corrected by the user.

The 11 LEDs on the front panel are the best and first place to look to determine what might be wrong with the MINV. The table on the next several pages is therefore organized by what these LEDs indicate, and for each indication there is a listing of what might possibly be wrong.

The front panel LED array is shown below. The designations of the 11 LEDs in this array are used in the following table.

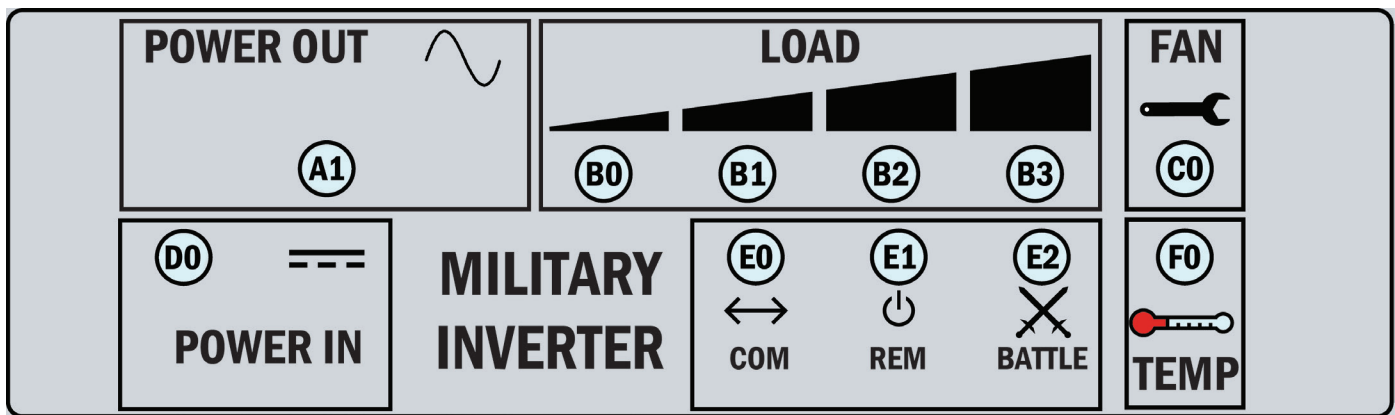

LED	Indication	Possible Problem(s)
D0: DC INPUT Power LED	LED is OFF	<ul style="list-style-type: none"> The DC INPUT power source is not turned on. The DC INPUT cable is not connected or it is wired wrong. The MINV is OFF and needs to be turned ON.
	LED is RED	<ul style="list-style-type: none"> The DC INPUT voltage is out of range.
A1: AC OUTPUT Power LED	LED is OFF	<ul style="list-style-type: none"> The MINV is OFF and needs to be turned ON.
	LED is AMBER	<ul style="list-style-type: none"> The AC OUTPUT load is higher than 4000W or 5000VA by enough to trigger the power limit circuitry. The AC OUTPUT load crest factor is too high. The AC OUTPUT is shorted within the cable or a load. Some other source of power is connected to the AC OUTPUT.
	LED is RED	<ul style="list-style-type: none"> The MINV has been turned OFF, but due to a malfunction within the MINV it is still running and providing an AC OUTPUT voltage. Some other source of voltage is connected to the AC OUTPUT and is powering it when the MINV is disabled.

LED	Indication	Possible Problem(s)
B0 – B3: LOAD POWER LEDs	B3 is BLINKING RED	<ul style="list-style-type: none"> Total MINV load power is greater than or approaching 4000W. The MINV may still be delivering its specified output voltage because the load power is not high enough to trigger the power limit circuitry.
	B0 – B3 are all OFF	<ul style="list-style-type: none"> No power is being delivered to the load. The MINV is OFF and needs to be turned ON. The loads or output cables are not connected. The loads are all turned off. The loads are simply not drawing any appreciable power at the time.
C0: Fan Service Required LED	LED is AMBER	<ul style="list-style-type: none"> One or both fans have recently had degraded performance but seem to be ok now. The MINV is running a diagnostic test.
	LED is RED	<ul style="list-style-type: none"> One or both fans presently have degraded performance, even if they are running, and service is recommended at the earliest convenient time. Ensure that the fan blades are not obstructed from turning
F0: MINV Cooling System LED	LED is BLINKING GREEN	<ul style="list-style-type: none"> Indicates that the fans are running at 50% of their rated speed. There is no problem.
	LED is AMBER	<ul style="list-style-type: none"> Indicates that the fans are running at 75% of their rated speed. There is no problem, but the unit is operating at a high ambient temperature and a high load combination.
	LED is RED	<ul style="list-style-type: none"> Fans are running at 100% of rated speed to keep the unit cool. The maximum recommended temperature may be exceeded, but the fans are keeping things cool enough to avoid triggering the over-temperature shut-down circuitry.
	LED is BLINKING RED	<ul style="list-style-type: none"> The maximum recommended temperature has been exceeded and the system is approaching over-temperature protection. The load and / or ambient temperature should be reduced if possible.
All LEDs:	All LEDs are OFF	<ul style="list-style-type: none"> The MINV is OFF and needs to be turned ON. The DC INPUT power is not turned ON.
Audible Alarm: (pattern repeats every 5 seconds)	One tone	<ul style="list-style-type: none"> The DC INPUT voltage is lower than the minimum operating level. Raise the DC INPUT voltage above the minimum level or verify the wiring is appropriate for the input current so as not to cause an excessive voltage drop.
	Two tones	<ul style="list-style-type: none"> The total MINV load power is above 4000 W. Loads should be reduced if this condition persists.
	Three tones	<ul style="list-style-type: none"> The AC OUTPUT has experienced either a short circuit or a load having a start-up surge current characteristic that the MINV could not start. The AC OUTPUT has therefore turned OFF. To reset, the MINV must be turned OFF and then ON.
	Four tones	<ul style="list-style-type: none"> One or more fans have encountered a fault or degraded performance. The MINV may still operate with degraded fan performance, but will require service. Ensure the fan blades are not obstructed.

Two other conditions should be mentioned:**• The fans are “OFF” when the MINV-4000-270 Unit is running**

It is normal for the fans to be “OFF”, even if the Unit is running and delivering power to the load, as long as the temperature of the Unit is low enough. If the Fan Service Required LED (F0) is green, both of the fans are OK, even if they are not running.

• The MINV-4000-270 Unit does not turn “OFF” when the “ON/OFF” switch is pushed down

When the “ON/OFF” switch on the front panel is pushed down, the Unit does not respond to this signal for approximately 1 second. This is done to ensure that the Unit is not accidentally turned “OFF”. If the user does not hold the “ON/OFF” switch in the “OFF” position for a full second before releasing it, the Unit will not turn “OFF”.

Other possible situations that are the result of external issues that a user could likely correct are related to:**• Loads that draw a large surge of current at start-up**

Several problems could arise with such a load:

Some AC loads draw a very large amount of current when an input voltage is first applied to them. This may also happen when the Unit is first turned “ON” if the load is already connected to the Unit. Or it may happen when the load itself is turned “ON” and/or connected to the AC OUTPUT of a Unit that is already running. Common examples of such loads are motors and incandescent lights, but some electronic equipment can also display this characteristic.

Several problems could arise with such a load:**• Loads that draw a large surge of current at start-up:**

SynQor's MINV-4000-270 is designed to try various start-up routines when it is first turned "ON" to overcome the problem of surge currents with some loads. There are three such routines, and each routine will be attempted three times. If the load is not started after these three routines (9 total attempts), the DC/AC section will latch off. This causes the AC output LED A0 to turn AMBER. To get the MINV to try again, the user should again push the "ON/OFF" switch on the front panel to the "OFF" position, then back to the "ON" position.

If there is more than one load connected to the AC OUTPUT that displays this start-up surge characteristic, and the MINV is not capable of starting all the loads at once, it may be possible to switch on the loads in a specific sequence, one by one allowing for a complete successful system power-up. For instance, if the MINV cannot start up a load consisting of lights and an induction motor that has a startup current 5 times larger than the operating current, it may be possible to start the induction motor first. Once the motor has reached its normal operating speed and current, then the lights can be turned "ON" without triggering the MINV's current limit protection.

• A newly started load disturbs the existing Unit loads.

A common problem can occur when the MINV is running and powering one or more loads connected to its AC OUTPUT, and then an additional load is turned "ON". If this newly started load draws a large surge current at start-up, it can cause the current limit of the MINV's AC OUTPUT to be triggered, which in turn causes the output voltage to drop. The drop could cause the existing loads to be disturbed. Furthermore, if the voltage drops is far enough below the rated limit, the MINV will turn "OFF" its AC OUTPUT and initiate a new start-up sequence. This latter action could cause an interruption of existing running loads. If this disruption in the loads is a problem, then the solution is to make sure that loads with large startup surges are started first, and then proceed to start the rest of the loads.

- **Input Cable wire resistance is too high:**

The resistance of the input power cable is too high due to an excessive cable length combined with an inappropriate cable size, loose panel/breaker terminals, connector contamination or corrosion. The accumulated resistance in the cable, drops the input voltage into the MINV-4000-270 below the rated limit during normal load condition. The phenomenon that may be displayed is as follows:

In standby mode, the MINV draws very little power/current from the DC input. The voltage drop across the DC input cable from the source to the MINV is therefore negligible at this point. The MINV sees that the voltage at the DC input is within the specified range, and enables the output; the load begins to draw power which in turn requires the MINV to draw current via the DC input cables and terminals. As the input current rises, a large voltage drop appears across the input cable and terminals. If the voltage into the MINV drops below the minimum rated value, the MINV may determine that the DC input is out of range and proceed to shut down. After this occurs, no current is being drawn through the input cables and terminals once again, the MINV detects that the DC input voltage is back to normal, and begins the startup sequence once again after a 1 second delay. The cycle will continue to repeat over and over, until voltage drop in the input circuit is corrected. The following are possible solutions to this problem: 1) make sure that the cable diameter for the required length is sufficient to deliver the full amperage to the MINV Unit, 2) tighten the distribution panel/breaker terminals or 3) clean any contamination or corrosion buildup on all terminals and connectors.

NOTES

NOTES

MINV **MILITARY FIELD-GRADE**

MILITARY GRADE POWER INVERTER

Operator's Guide *MINV-4000-270 Series*



Made in USA

006-0007361

07/10/2024

REV B

SynQor[®]
Advancing The Power Curve[®]