

# MINV **MILITARY FIELD-GRADE**

## MILITARY GRADE POWER INVERTER



### Operator's Guide *MINV-4000-1U-28 Series*



MINV-4000-1U-28

*N+M Redundancy  
(optional)*

**SynQor**  
Advancing The Power Curve®

# Table of Contents

## SECTION I

## WARNINGS

<i>Hazardous Voltages</i> .....	4
<i>Hazardous Energies</i> .....	4
<i>Protection from the Environment</i> .....	5
<i>User Serviceable Parts</i> .....	5

## SECTION II

## GENERAL PRODUCT INFORMATION

<i>Product Description</i> .....	6
<i>Product Topology</i> .....	7
<i>Part Numbering Scheme and Options</i> .....	9
<i>Product Specifications</i> .....	10
<i>Technical Specifications</i> .....	11
<i>1U Mechanical Diagram</i> .....	12
<i>MINV Efficiency</i> .....	13
<i>Total Output Power that can be derived from the DC INPUT</i> .....	13
<i>Power Cable Wiring Diagram</i> .....	14
<i>Power Cable Wiring Size</i> .....	15

## SECTION III

## OPERATION

<i>Set-Up</i> .....	16
<i>Start-Up</i> .....	16
<i>Shut-Down</i> .....	16
<i>Power Cable Connections</i> .....	17
<i>Cooling System</i> .....	17
<i>Front Panel Indicators</i> .....	18
<i>Audible alarm</i> .....	20
<i>Operating Environment</i> .....	21

## SECTION IV

## MULTIPLE UNIT CONFIGURATION

<i>General Considerations</i> .....	22
<i>Expanded Paralleling -F Option</i> .....	23
<i>Redundant Paralleling -R Option</i> .....	24
<i>Possible configurations of the AC OUTPUTs</i> .....	25
<i>Multi-unit Configurations</i> .....	25
<i>Parallel Connection of the AC Outputs</i> .....	26
<i>Two MINV units with AC OUTPUTs Paralleled</i> .....	26
<i>Three MINV units with AC OUTPUTs Paralleled</i> .....	27
<i>Series Split-Phase Connection of AC Outputs</i> .....	28
<i>Series 3-Phase Connection of AC Outputs</i> .....	29
<i>Parallel Configurations of the AC OUTPUTs: Up to 32 Units</i> .....	30
<i>Connection of the DC INPUTS</i> .....	32
<i>Multi-Unit AC OUTPUT On/Off Control – Expanded/Redundant Parallel (-F/-R option)</i> . 32	
<i>AC OUTPUT Neutral Grounding</i> .....	32
<i>Wiring Caution</i> .....	32

## SECTION V

## CONTROL INTERFACE DETAILS

<i>Control Cable Connections</i> .....	33
<i>Internal User I/O Circuits</i> .....	34
<i>Remote On/Off Switch Connections</i> .....	34
<i>Digital Input/Output Control Signals</i> .....	35
<i>RS232 Serial Interface</i> .....	36
<i>Ethernet Interface</i> .....	37
<i>Synchronized Operation of Multiple Units</i> .....	38
<i>Turn-On, Turn-Off, Restart Control</i> :.....	38
<i>Sleep Mode</i> .....	39

## SECTION VI

## MAINTENANCE

<i>Fans</i> .....	40
<i>Cleaning</i> .....	41

## SECTION VII

## TROUBLE-SHOOTING GUIDE

<i>Fault Conditions</i> .....	42
-------------------------------	----

### Hazardous Voltages

The **INPUT AND OUTPUT POWER** connectors and cables of the SynQor MINV may have voltages that are unsafe. **INJURY OR DEATH ON CONTACT** may result. Appropriate safety precautions should be taken. All connections should be made in accordance with **LOCAL ELECTRICAL CODES**.

- The MINV **CHASSIS** should be connected to earth or system ground with Ground Stud on the rear panel, see mechanical diagrams.
- For the **DC INPUT** cable and connector:
  - The rated DC input voltage of the MINV is below the level considered hazardous.
  - The DC input terminals of the MINV are isolated from the AC output with reinforced safety insulation.
  - However, never assume the terminals of the DC input connector or the wires of the DC input cable are safe to contact, even if the MINV appears to be off.
- For the **AC OUTPUT** cable and connector:
  - Do not assume that a hazardous voltage is not present at the terminals of the AC output connector, even if the MINV appears to be off.
  - Do not make contact with the terminals of the AC output connector.
  - Connect the AC output cable to the MINV before the MINV is turned on.
  - If connection of the load to the AC output cable has exposed conductors, make this connection before connecting the AC output cable to the MINV.
  - Connections between the AC output cable and the AC load should not be accessible.

### Hazardous Energies

The **INPUT AND OUTPUT POWER** connectors and cables of the SynQor MINV may be the source of high levels of energy. Do not inappropriately make electrical contact between any terminal of a connector and another, or between any wire of a cable and another, or between any terminal or wire and the MINV's chassis or ground. **DAMAGING ELECTRICAL ARCS** may result. Care should be taken to avoid accidental electrical contacts of this sort.

### *Protection from the Environment*

The SynQor MINV is a ruggedly built product having its electronics contained in a sealed chamber. It is capable of withstanding harsh levels of mechanical acceleration, shock and vibration, temperature and pressure variations, and exposure to water, salt, sand and dust within the levels specified in the data sheet. **THESE LEVELS SHOULD NOT BE EXCEEDED.**

Do not obstruct the air intake in the front of the MINV or the fan exhausts in the rear panel of the MINV while the MINV is operating.

### *User Serviceable Parts*

The MINV fans are user replaceable with kits available from SynQor. Please contact the SynQor factory for obtaining fan replacement kits and instructions (Counter-Rotating Replaceable Fan Module SYN-9452). The SynQor MINV has no other user serviceable parts inside of it. **DO NOT REMOVE** the cover of the MINV or any of its connectors. Other than the fan assembly replacement, only factory trained personnel should perform repairs.

### *Product Description*

SynQor's Military Inverter units are designed for the extreme environmental and demanding electrical conditions of Military/Aerospace applications. SynQor's MINV incorporates field proven high efficiency designs and rugged packaging technologies. This MINV will accept a DC input voltage while delivering a well-conditioned continuous 4000 W, AC output to the load. It is designed and manufactured in SynQor's USA facilities to comply with a wide range of military standards. Options include a selection of output voltage amplitudes, frequencies, and an electronic breaker on the AC output to permit fault-tolerant parallel operation for higher power and/or N+M redundant systems.

A communication/control port is available to permit monitoring and control by a host computer system. Front panel LEDs provide information on the status of the MINV.

The electronic circuitry within the MINV-4000 Series products is designed, qualified and screened according to SynQor's MIL-COTS Standards. It complies with the requirements of MIL-STD-704F, MIL-STD-1399-300B, MIL-STD-1275D and MIL-STD-461F, as well as IEC-EN61000 specifications for world-wide commercial utility applications.

The MINV-4000 Series products are designed and manufactured to withstand the harsh environments and use encountered in military applications. The electronic circuitry is contained in a sealed chamber constructed from a die-cast aluminum chassis that is weather-proof and shock-proof. Redundant, water-proof fans on the rear panel draw cooling air over the heat-sink fins below the sealed chamber. Military-grade circular connectors are used, and optional attached connector covers are available for when the cables are not attached. The MINV-4000 Series products comply with a wide range of testing according to MIL-STD-810G.

The SynQor MINV-4000 Series products are designed and manufactured in the U.S.A.

## *Product Topology*

The SynQor MINV-4000 Series products use an isolated topology that provides protection to the load from spikes, noise, surges, brownouts, blackouts, etc. in the input power sources. They also provide smoothing of load transients and nonlinear load profiles so that the input power source is not subjected to these disturbances.

EMI filters are present at all external inputs and outputs.

Power flows from the DC INPUT through an isolated DC-DC converter. The AC OUTPUT is created by an inverter that draws power from the mid-bus. The inverter provides high-frequency safety isolation and a pure-sinusoidal output voltage waveform. An optional electronic breaker can be added to the AC OUTPUT. This one pole hot side only electronic breaker allows for fault-tolerant, glitch-free operation when several MINV units are placed in parallel.

Bulk energy storage capacitors are connected to the mid-bus to help smooth imbalances in power flow between the inputs and outputs of the MINV.

There is a communication/control port that provides a digital interface to a host computer system.

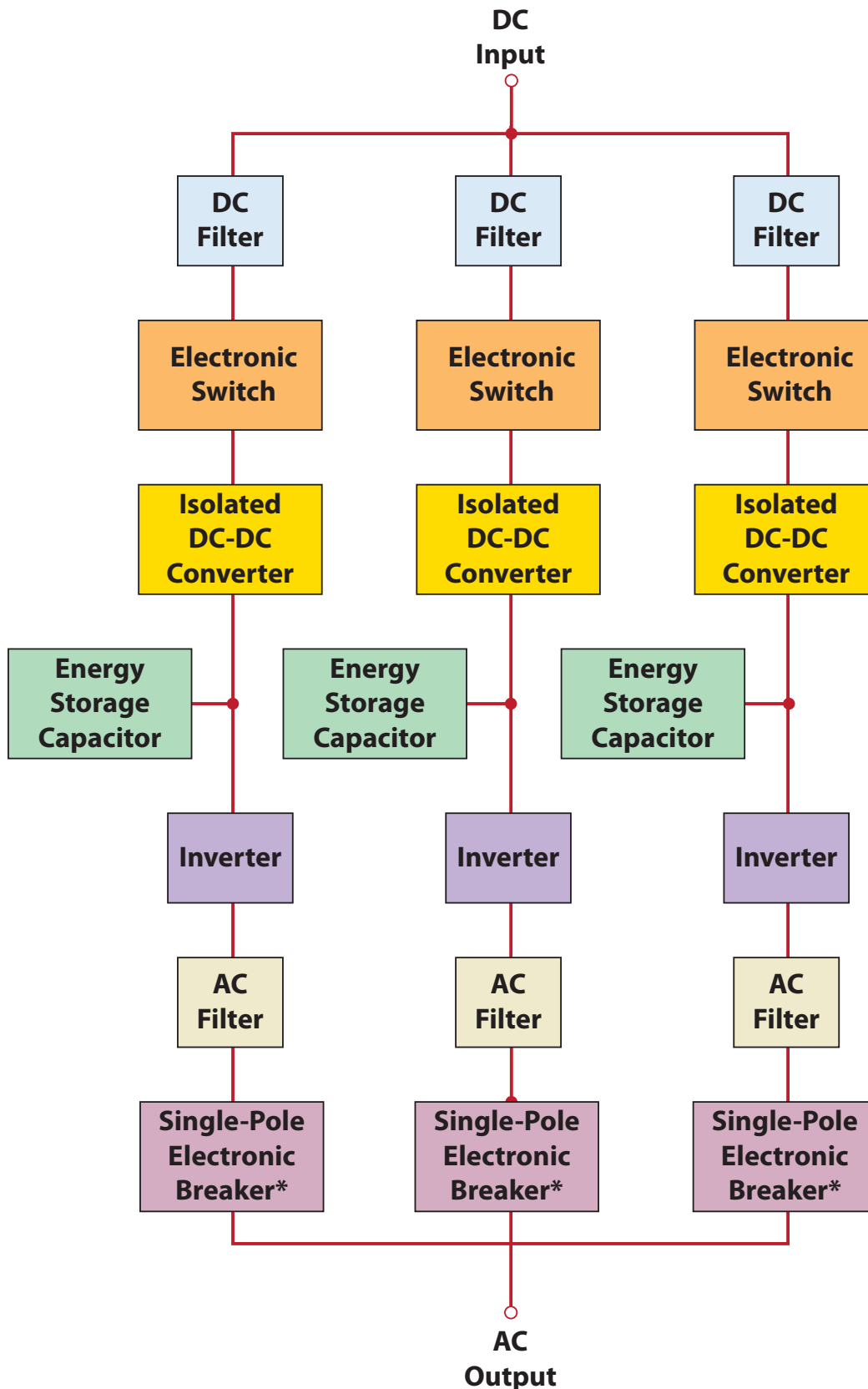

**\* Single-Pole Electronic Breaker installed on all AC output filter modules when ordering "R" option**

**Part Numbering Scheme and Options**

This table shows the part numbering scheme for the full line of SynQor MINV products:

Base Models				
Model Number	Power	Nominal DC Input Voltage	Height (W x D x H)	Weight
MINV-4000-1U	4000 W 5000 VA	28 V	1U (17.00" x 22.43" x 1.73")	32 lbs.

Base Models	Options						Options	
	DC Input Voltage	AC Output Voltage	AC Output Neutral Wire	AC Output Set Point Freq	Output Config	Additional Options	DC Input Voltage	Options
MINV-4000-1U-	28	1 2	G F R	5 6 4	S	-E 00 CE	28	20 - 33 V
							AC Output Voltage	1 115 Vrms 2 230 Vrms
							AC Output Neutral Wire	G Grounded F Floating* R AC Output Electronic Breaker*
							AC Output Set Point Freq	5 50 Hz 6 60 Hz 4 400 Hz
							Output Config	S Single-Phase Output
							Additional Options	-E Ethernet/SNMP with Configuration Loading 00 No CE Marking CE CE Marking

Not all combinations make valid part numbers, please contact SynQor for availability. See the Product Summary web page for more options.

**\*Notes:**

Order "F: Floating" option when configuring the AC output for multi-unit combinations of up to 3 units.

Order "R: AC Output Electronic Breaker" option for fault-tolerant, glitch-free parallel systems of up to 32 units with N+M redundancy. The AC output neutral wire will not be connected to the chassis.

**Examples:**

MINV-4000-1U-28-1G6S-E00

MINV-4000-1U-28-2G5S-ECE (230 V output with CE marking)

The MINV-4000 Series of products provide up to 4000 W of total AC output power.

- A 1U high, 32 lbs. rackmount unit.

Each format has various options that can be specified according to the part numbering scheme shown in the table:

- The AC OUTPUT voltage of the MINV-4000 series can be 115 Vrms or 230 Vrms.
- The AC OUTPUT can be configured with its neutral wire intentionally grounded to the chassis of the MINV or left floating for shipboard or paralleling applications of up to 32 units.
- The initial set-point frequency of the AC OUTPUT voltage can be 50 Hz, 60 Hz, or 400 Hz. Regardless of the initial set-point frequency, the actual frequency can be set through the communications/control port.
- The Electronic Breaker option adds fault-tolerant, glitch-free multi-unit operation for N+1 or N+M redundancy up to 32 units. This option allows up to 32 units total in Single Phase, Split Phase, or 3-Phase systems.
- RS232 serial port and logic-level I/O communication are included in the standard model. An Ethernet port provides web and SNMP interfaces.

**Product Specifications**

The following three pages show the electrical and mechanical specifications of the MINV-4000-1U-28 high Series of products. Data sheets showing these specifications and other information can be found at the web site <https://www.synqor.com/MINV>.

*MINV-4000-1U-28 Front Panel*



*MINV-4000-1U-28 Rear Panel*

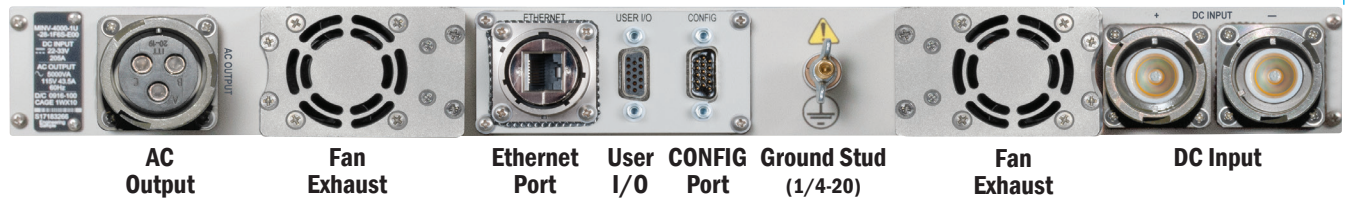

## Technical Specifications

### DC INPUT CHARACTERISTICS

Steady State Operating Voltage	20 - 33 V
Continuous Maximum Input Current	240 A (full load, 20 V)
Transient Operating Voltage	18 - 40 V (500ms @ 18 V)
Transient Maximum Input Current	275 A

### AC OUTPUT CHARACTERISTICS

Total Output Power Continuous	4000 W (5000 VA)
AC Output Waveform	Pure Sinusoidal
Voltage Line-Neutral	115 Vrms $\pm$ 3% 230 Vrms $\pm$ 3%
Frequency	60 Hz $\pm$ 0.5% 50 Hz $\pm$ 0.5% 400 Hz $\pm$ 0.5%
Load Power Factor	0-1.0 (leading or lagging)
Total Harmonic Distortion	2% (3000 W resistive load)

### Single-Phase Output

Steady State Load Current	43.5 Arms (115 Vrms) 21.7 Arms (230 Vrms)
Peak Load Current	78 Apk (115 Vrms) 39 Apk (230 Vrms)

Specifications subject to change without notice.

\* Regarding MIL-STD-461 CE-101, the 50  $\mu$ H series inductance of a standard LISN adversely affects the input ripple of the MINV. Such a large series source inductance (50  $\mu$ H in each power lead) is not generally encountered in a 28 V DC source of such high power rating. Therefore, testing for CE-101 (DC input) was conducted with 3 different configurations: two using 50  $\mu$ H LISNs and a 54 mF capacitor connected across the input to the MINV, and one using 5  $\mu$ H LISNs for which no additional capacitor was added. These configurations all passed CE-101 for all frequencies.



## MINV in Transit Case Option

### ENVIRONMENTAL CHARACTERISTICS MIL-STD-810G

#### Temperature Methods 501.5, 502.5

Operating Temperature	
Full Rated Power	-40 °C — +55 °C
Reduced Power per Figure B	-40 °C — +70 °C
Storage Temperature	-40 °C — +70 °C

#### Altitude Method 500.5

Operating	0 - 18,000 ft
Non-operating	0 - 40,000 ft

#### Environmental Tests

Shock/Drop	Method 516.6, Procedures 1,4,6
Temperature Shock	Method 503.5, Procedure 1
Vibration	Method 514.6, CAT 5, 7, 8, 9, 24
Fungus	Method 508.6
Salt Fog	Method 509.5
Sand and Dust	Method 510.5, Procedures 1,2
Rain	Method 506.5 Procedure 1
Humidity	Method 507.5 Procedure 2
Mechanical Vibrations of Shipboard Equipment	Method 528 Procedure 1

### RELIABILITY CHARACTERISTICS MIL-HDBK-217F

MTBF	468 kHrs	MIL-217F Ground Benign, Ta=25 °C
------	----------	----------------------------------

### ELECTROMAGNETIC CAPABILITY MIL-STD-461F

CE101*	30 Hz - 10 kHz
CE102	10 kHz - 10 MHz
CS101	30 Hz - 150 kHz
CS106	10 kHz - 40 GHz
CS114	10 kHz - 200 MHz
CS116	10 kHz - 100 MHz
RE101	30 Hz - 100 kHz
RE102	10 kHz - 18 GHz
RS101	30 Hz - 100 kHz
RS103	2 MHz - 40 GHz

### MECHANICAL CHARACTERISTICS

#### 1U Standard Chassis

Chassis Size (W x D x H)	17.00 "W x 22.43 "D x 1.73 "(1U)H
Case Material	Aluminum
Total Weight	32 lbs.

#### DC Input Connectors

DC (-) Input Connector	CGE2E18H5ZWB-16
DC (+) Input Connector	CGE2E18H5ZB16

#### AC Output Connectors

115 V Single Phase	CB2-20-19SXS
230 V Single Phase	CB2-20-19SXS

#### I/O Ports

User I/O Ports	HD DB15 Female
Configuration I/O Port	HD DB15 Male
Ethernet Port	Amphenol RJF22N00, Code B

#### Cooling Exhaust Fans

Sound Pressure Level (SPL)	64 dB(A)
Air Flow	0.92 (m <sup>3</sup> /min) 32.5 CFM

Two fans in system, above specs are for each fan separately.

1U Mechanical Diagram

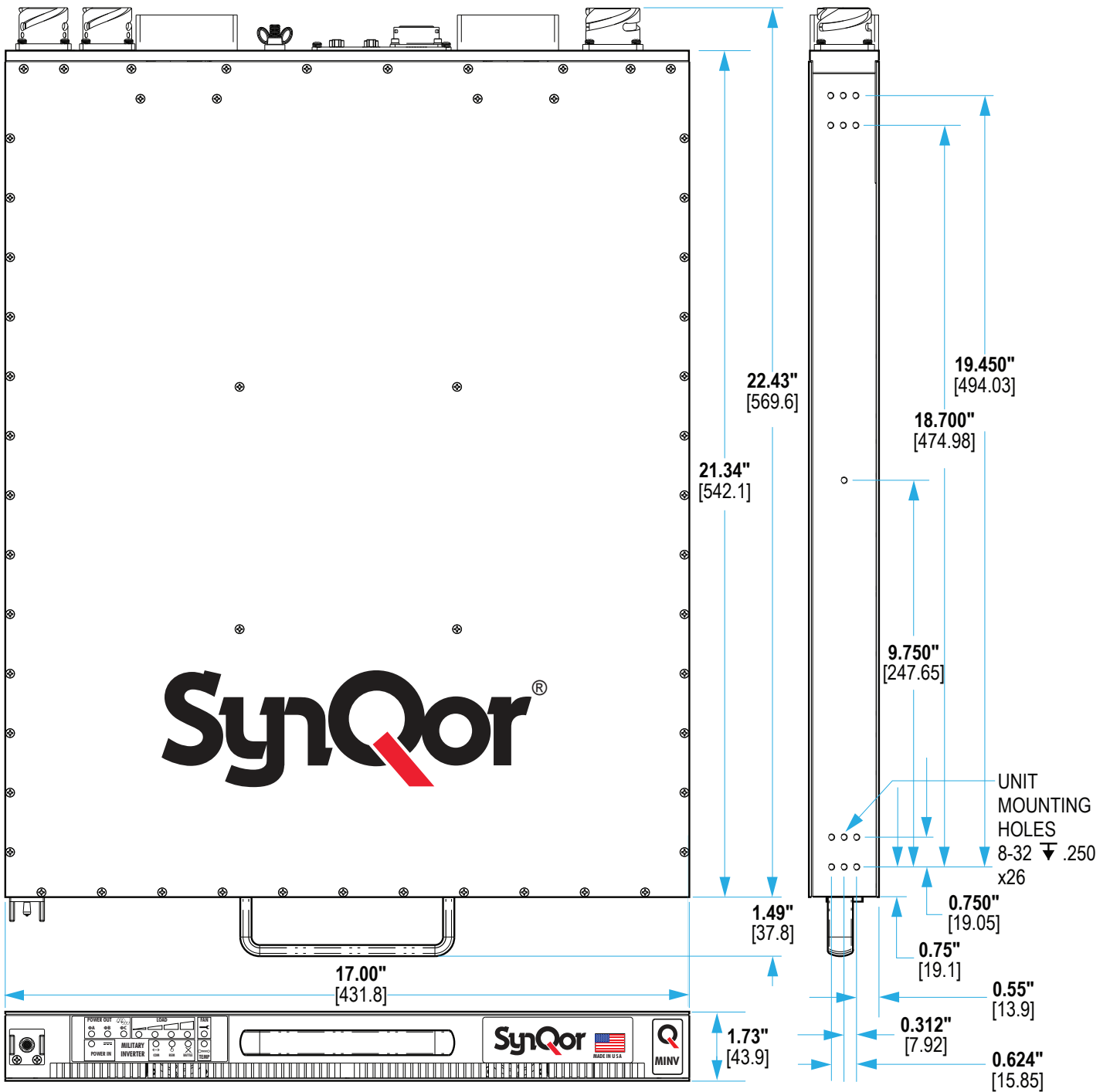

**MINV Efficiency**

Figure 1 shows the typical efficiency with which the MINV-4000 series power supplies delivers power to its AC OUTPUT from a 22 V DC INPUT, 28 V DC INPUT, and 33 V DC INPUT:

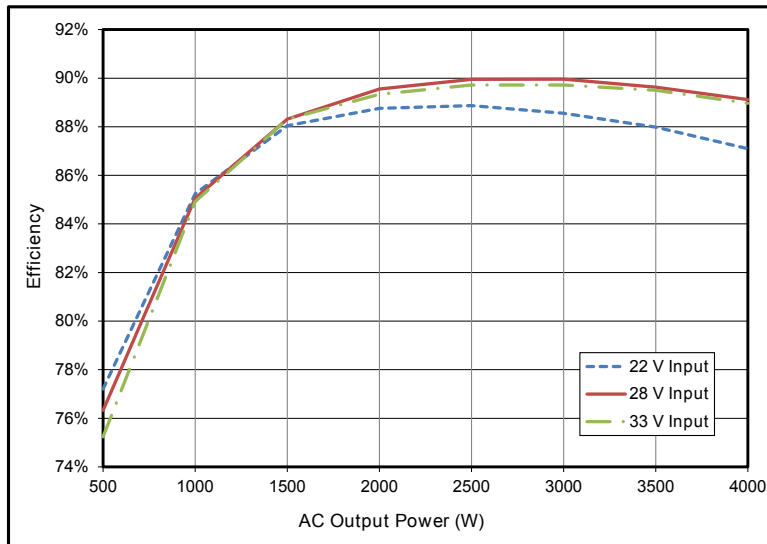

Figure 1

**Total Output Power that can be derived from the DC INPUT**

The total MINV output power for the MINV-4000 series is rated at 4000 W for an ambient temperature as high as 55 °C (131 °F).

The maximum steady-state output power as a function of ambient air temperature and DC input voltage is shown below in Figure 2.

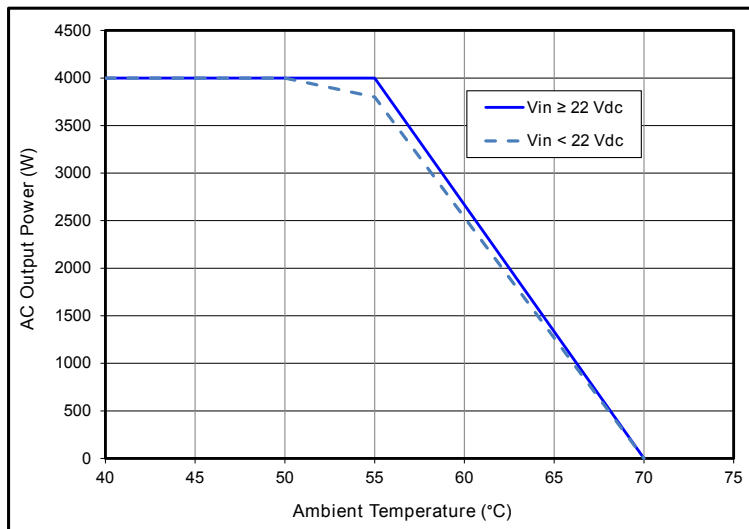
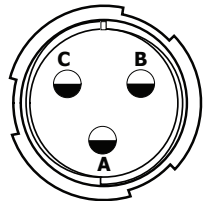

Figure 2

## Power Cable Wiring Diagram

Looking at the rear panel, the MINV connector terminals have the following functions and locations:

AC OUTPUT	
Pin	Function
A	Line
B	Neutral
C	Ground



DC INPUT	
Key	Function
A	-V

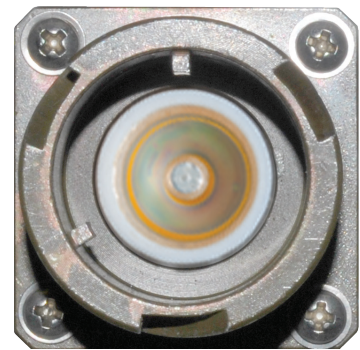
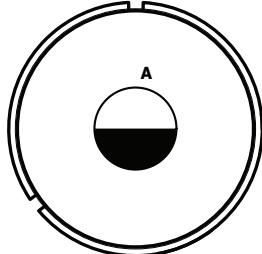

DC INPUT	
Key	Function
B	+V

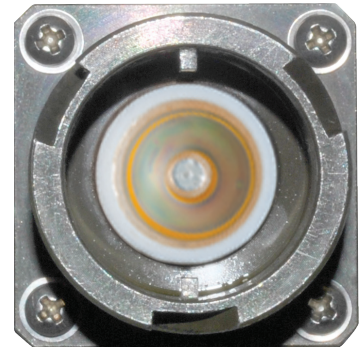
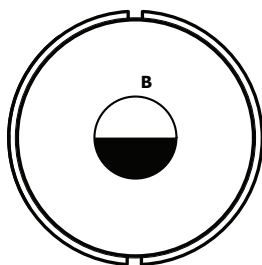

### Power Cable Wiring Size

SynQor recommends the following cables for use with the MINV-4000 series:

AC Output: SYN-9630 MINV connection to hardwire termination, 10'  
DC Input: SYN-9651 MINV positive connection to hardwire termination, 10'  
SYN-9652 MINV negative connection to hardwire termination, 10'

Other options may be available. Contact [info@synqor.com](mailto:info@synqor.com) or visit the website: <https://www.synqor.com> for more information. If it is necessary to develop custom cables for your application, please read through the following section for some important considerations. Damage caused by improper wiring of cables will not be covered under SynQor's warranty.

Both the input and output cables of the MINV carry substantial current, and since the wires in these cables have resistance the current flowing through them causes a voltage drop from one end of the cable to the other. In other words, the voltage across the cable at its downstream end is smaller than the voltage across the cable at its upstream end. Mathematically, the amount that the voltage drops is equal to the resistance of the cable's wire multiplied by the current flowing through the wire. It is therefore important to make sure that the resistance of the cable's wire is small enough to keep this voltage drop to an acceptably small value.

While this is an issue for all of the power cables, it is particularly important for the DC INPUT cables because the current flowing through it is very high (as high as 240 A for the MINV-4000 Series) and the voltage across it is already relatively small (as low as 20 V). In fact, a common problem that arises (when the DC INPUT cable has too small a wire) is that the voltage seen at the DC INPUT of the MINV falls below the minimum specified value of 20 V even though the voltage at the source of the DC power is greater than 20 V. Under this condition the MINV will turn off its output even though the voltage at the DC source of power appears to be available and at a proper level.

The resistance of a wire depends directly on its length. A wire twice as long as another will have twice the resistance, holding all other things constant. The resistance also depends on the reciprocal of the cross-sectional area of the wire, which in turn depends on the square of the wire's diameter. A wire with half the diameter of another will therefore have four times the resistance, holding all other things constant.

Therefore, the longer a cable is, the more important it is that the wire's diameter be large. SynQor recommends that for the MINV-4000 Series:

- The AC OUTPUT cable has 3 wires (one for the ground) of  $\geq 8$  AWG for the 115 V output model and  $\geq 12$  AWG for the 230 V output model
- The DC INPUT cable has 2 wires (one for each pole) of 0 (1/0) AWG

Additional details about the effects of a resistance-related voltage drop are included in "Trouble-Shooting Guide - Cable wire resistance is too high".

### Set-Up

The recommended procedure for setting up the MINV is the following:

- Connect the ground wire to the ground stud on the rear panel of the MINV.
- Connect the AC OUTPUT cables, first to the MINV and then to the load.
- Connect the USER I/O cables.
- Connect the DC INPUT cables, first to the MINV and then to the DC source.
- An overcurrent protect and disconnect device should be installed on the DC INPUT circuit. An example of a suitable device is a Carling Technologies, F-series, 300 A 125 Vdc, FA2-P0-14-830-22A-BT circuit breaker. ([www.carlingtech.com](http://www.carlingtech.com))
- VERIFY that the DC INPUT cables are connected to the MINV and the source of DC power with the correct polarity.
- Turn on the source (if it has an up stream breaker).

### Start-Up

- VERIFY that all connections to the MINV are correct.
- If the DC source is present and within specifications, the single POWER IN LED on the front panel will be green.
- Momentarily push the ON/OFF switch on the front panel of the MINV upward. The switch can then be released and it will return to its normal (neutral) position.
- The MINV will immediately enable its outputs (assuming there is no fault condition). The color of the POWER OUT LED(s) on the front panel will change to green. The LOAD LEDs on the front panel will indicate the amount of power being delivered to the load

### Shut-Down

- Shut down the equipment connected to the MINV.
- Push the ON/OFF switch on the front panel of the MINV downward and hold it in this position for 1 second (or more). The switch can then be released to return to its normal position.
- The MINV will disable its outputs.

### Power Cable Connections

**For safety reasons**, the input and output power cables should be connected to the MINV before the source of DC power is turned on, and before the MINV is turned on (see **Section I: Warnings** and the **SET-UP** section above). Similarly, one should first turn off the MINV and the source of input power before any power cables are disconnected from the MINV.

**ALSO NOTE** that when the MINV is turned on and delivering power to a load, and then another piece of equipment is connected to the same output, it is possible that this connection will momentarily disrupt the quality of the MINV's output voltage. For instance, consider the case where the AC OUTPUT power cable has a terminal strip that allows several loads to be connected to it. If the MINV is turned on and delivering power to several of these loads and then another load is connected to the terminal strip, it is possible that this new load will momentarily draw a large surge of current as it starts up. If this happens, the output of the MINV could reach its maximum current limit, and the MINV will reduce its output voltage to keep the current from getting any larger. This reduction in voltage will be corrected once the new load reaches its normal mode of operation, but in the meantime the reduction of the MINV's output voltage might cause one or more of the other loads to malfunction. Whether or not this will be a problem depends on the characteristics of the various loads.

### Cooling System

The SynQor MINV-4000 Series products are cooled by dual counter-rotating fans that draw air into the intake on the front panel and exhaust it out the two fan ports on the rear panel. Care should be taken to ensure there is no obstruction to this airflow, either at the front intake or the rear exhaust ports. Similarly, care should be taken to avoid obstructing the fan blades.

The speed of the cooling fans is automatically controlled to provide adequate MINV cooling while extending the life of the fan bearings. Under low ambient temperature and/or low MINV output power the fans will be driven at a low speed or turned off. Fan speed is increased by the internal controller based upon readings from multiple internal temperature sensors.

If the ambient temperature is low enough (for the level of power being delivered to the load), the fans may not be on. This is not a malfunction. It is done to preserve the life of the fans. If the fans are off, check the Fan Service Required LED on the front panel of the battery pack. If it is GREEN, the fans are functioning properly and simply not needed under the present conditions.

The fans are weather-proof and water-proof.

The MINV has two fans to provide redundancy for these exposed, moving components. With only a single operating fan the MINV is still able to deliver 80% rated power at an ambient temperature of 40°C, and it is able to deliver 60% of its rated power at an ambient temperature as high as 55°C.

**Front Panel Indicators**

To indicate the status of the MINV there are 11 LEDs on the front panel. These indicators are described in this section.

**LEDs**

Each MINV has up to 11 LEDs, as shown below, that indicate the status of the operation of the MINV:

MINV Single Output LED Status Label

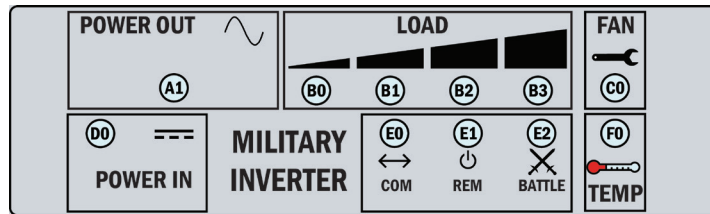

• **Power-In Indicator (LED in position D0)**

The LED D0 indicates the status of the DC INPUT, according to the table below:

LED Appearance	Description	Indication
	<b>Green</b>	<i>Input is Ready to Provide Load Power</i>
	<b>Amber</b>	<i>Not Applicable</i>
	<b>Red</b>	<i>Input is Out of Range</i>
	<b>Off</b>	<i>MINV is Unpowered</i>





• **Power-Out Indicator (LED in position A1)**

The LED in position A1 indicates the status of the AC OUTPUT, according to the table below

LED Appearance	Description	Indication
	<b>Green</b>	<i>MINV is Enabled and the Output Voltage is Within Range</i>
	<b>Amber</b>	<i>MINV is Enabled but the Output Voltage is Out of Range</i>
	<b>Red</b>	<i>MINV is Disabled due to Input Out of Range or Output Fault.</i>
	<b>Off</b>	<i>MINV is Disabled</i>



• **Load Power Indicators (LEDs in positions B0 – B3)**

The LEDs in positions B0 through B3 indicate the total output power of the MINV according to the table:

LED Appearance	Description	Indication
	<i>B0 Dimmed Green; B1-B3 Off</i>	<i>Total Load Power &lt;25%</i>
	<i>B0 Green; B1 Dimmed Green; B2-B3 Off</i>	<i>Total Load Power &lt;50%</i>
	<i>B0, B1 Green; B2 Dimmed Green; B3 Off</i>	<i>Total Load Power &lt;75%</i>
	<i>B0, B1, B2 Green; B3 Dimmed Green</i>	<i>Total Load Power &lt;100%</i>
	<i>B0; B1; B2 Green; B3 Blinking Red</i>	<i>Total Load Power ≥100%</i>





• **MINV Fan Service Required Indicator (LED in position C0)**

The LED in position C0 indicates whether the two cooling fans in the rear panel of the MINV are OK or if their performance is degraded, according to the table below:

LED Appearance	Description	Indication
	<b>Green</b>	<i>Both Fans are OK</i>
	<b>Amber</b>	<i>One or Both Fans Have Recently Had Degraded Performance and Diagnostic Tests are Being Performed</i>
	<b>Red</b>	<i>One or Both Fans Presently Have Degraded Performance</i>



• **MINV Cooling System Indicator (LED in position F0)**

The LED in position F0 indicates the temperature and status of the cooling system for the MINV according to the table below:

LED Appearance	Description	Indication
	<b>Green</b>	<i>Moderate MINV Temperature (Fans Running at 25%)</i>
	<b>Blinking Green</b>	<i>Warm MINV Temperature (Fans Running at 50%)</i>
	<b>Amber</b>	<i>Elevated MINV Temperature (Fans Running at 75%)</i>
	<b>Red</b>	<i>Maximum MINV Temperature (Fans Running at 100%)</i>
	<b>Blinking Red</b>	<i>Over Temperature Warning (Fans Running at 100%)</i>

- Control Status (LED in position E0, E1, E2)**

The LED in position E0, E1 or E2 indicates whether RS232 or Ethernet Port, Remote Enable/Shutdown or Battle Short are active:

LED Appearance	Description	Indication
	<b>Green</b>	<i>E0: RS232 active or Ethernet Port Active, E1: Remote Enable Active</i>
	<b>Blinking Red</b>	<i>E2: Battle Short Mode Active, Temperature Shutdowns Removed</i>
	<b>Red</b>	<i>E1: Remote Shutdown Active</i>

### **Audible alarm**

For critical situations a pattern of audible tones will be repeated every 5 seconds, according to the table below. This audible alarm can be **silenced** by holding the ON/OFF switch on the front panel in the “UP” position while the MINV is operating and its output is running, or in the “DOWN” position while in Standby Mode, until a chirp is heard. A new alarm condition will cause the audible alarm to be reactivated. Contact Factory for instructions on how to permanently silence the alarm.

Number of Tones in Pattern	Indication
<b>One</b>	<i>Input Voltage is Out of Range</i>
<b>Two</b>	<i>Load Power is greater than or Approaching 100% Rated Power</i>
<b>Three</b>	<i>Fault Appears on the AC Output MINV Must be Turned Off and Back On to Reset Fault</i>
<b>Four</b>	<i>One or More Fans have Encountered a Fault and Require Service</i>

### Operating Environment

The SynQor MINV-4000 Series is designed for the extreme environmental conditions of military and aerospace applications. All the electronic circuitry is contained in a sealed, weather-proof, shock-proof chamber constructed of die-cast aluminum. Only the redundant, water-proof cooling fans are exposed to the environment. The MINV will shut down if it is too hot and Battle Mode is not active.

The MINV (with cables connected or connector covers installed) has been qualified to the following requirements of MIL-STD-810G:

MIL-STD-810G Test Method	Name	Procedure	Details
500.5	Low Pressure	I, II and III	<ul style="list-style-type: none"> <li>▪ 18,000 ft. operating</li> <li>▪ 40,000 ft. storage</li> </ul>
501.5	High Temperature	I and II	<ul style="list-style-type: none"> <li>▪ +55 °C operating</li> <li>▪ +70 °C storage</li> </ul>
502.5	Low Temperature	I and II	<ul style="list-style-type: none"> <li>▪ -40 °C operating</li> <li>▪ -40 °C storage</li> </ul>
503.5	Temperature Shock	I	<ul style="list-style-type: none"> <li>▪ 10 cycles; &gt;10 °C/minute</li> </ul>
506.5	Rain	I	<ul style="list-style-type: none"> <li>▪ 4" rain/hour</li> <li>▪ 40 mph wind velocity</li> </ul>
507.5	Humidity	II	<ul style="list-style-type: none"> <li>▪ &gt;95%</li> </ul>
508.6	Fungus	NA	<ul style="list-style-type: none"> <li>▪ 28 day test</li> </ul>
509.5	Salt Fog	NA	<ul style="list-style-type: none"> <li>▪ 5% salt solution</li> <li>▪ 2 cycles (24 hr wet/24 hr dry)</li> </ul>
510.5	Sand and Dust	I and II	<ul style="list-style-type: none"> <li>▪ 20 mph blowing dust</li> <li>▪ 40 mph blowing sand</li> </ul>
514.6	Vibration	Category 5	<ul style="list-style-type: none"> <li>▪ 5Hz (300 RPM)</li> <li>▪ Loose Cargo</li> </ul>
514.6	Vibration	Category 7	<ul style="list-style-type: none"> <li>▪ General Exposure</li> </ul>
514.6	Vibration	Category 8	<ul style="list-style-type: none"> <li>▪ C-130 Aircraft level</li> </ul>
514.6	Vibration	Category 9	<ul style="list-style-type: none"> <li>▪ General Exposure</li> </ul>
514.6	Vibration	Category 24	<ul style="list-style-type: none"> <li>▪ PSD = 0.4 g<sup>2</sup>/Hz; 1-2000 Hz</li> <li>▪ Operating</li> </ul>
516.6	Shock	I, IV and VI	<ul style="list-style-type: none"> <li>▪ 20 g/20 ms; 40 g/11 ms; 75 g/6 ms</li> <li>▪ 48 inch drop in transit case</li> <li>▪ 30 degree tilt and drop</li> </ul>
528	Mechanical Vibrations of Shipboard Equipment	I	<ul style="list-style-type: none"> <li>▪ Operating</li> </ul>

### General Considerations

The MINV supports two different paralleling schemes for the AC output: expanded paralleling and redundant paralleling. With expanded paralleling, up to 32 MINV units can be combined to form high power Single-Phase, split-phase and 3-Phase systems.

With redundant paralleling an electronic breaker on the hot AC output wire provides fault-tolerant, glitch-free operation should one MINV unit fail. This allows users to add extra MINV units to the system for N+1 redundancy, or more generally N+M redundancy.

Expanded vs. redundant paralleling is determined by the “AC Output Neutral Wire” option in the MINV part number. See the table below. Expanded paralleling units cannot be mixed with redundant parallel units in multi-unit systems.

Ordering Information: Expanded Vs Redundant Parallel		
	AC Output Neutral Wire option	Example PN
Single Unit (no paralleling)	G	MINV-4000-1U-28-1 <b>G</b> 6S-E00
Expanded Parallel	F	MINV-4000-1U-28-1 <b>F</b> 6S-E00
Redundant Parallel	R	MINV-4000-1U-28-1 <b>R</b> 6S-E00

**Note:** When combining MINV units into the configurations described in this section, each MINV must internally have the neutral wire of its AC OUTPUT floating, rather than connected to its chassis. This requires that all the MINV units have the “F” option for expanded parallel units and “R” option for redundant parallel units regarding the AC OUTPUT neutral wire connection. Check the MINV part numbers to be sure this is the case before ordering.

### *Expanded Paralleling -F Option*

With expanded paralleling, up to 32 SynQor MINV units with identical model numbers can be combined in various ways to achieve:

- Higher output power
- Higher output voltage
- Multiple output phases
- A balanced or unbalanced load for a 3-Phase AC input source

A configuration-specific CONFIGURATION cable determines each MINV unit's role in an expanded parallel system. These CONFIGURATION cables are available from SynQor, and the proper part number for any configuration is given in the pages that follow.

Configuration-specific OUTPUT and/or INPUT power cables are also required. These power cables can be assembled by the user following the wiring diagrams that follow, using the SynQor power cables with hardwire terminations.

In an expanded parallel system, the AC output will remain off until one MINV unit is enabled. This can be done by actuating the front panel switch "on", or by sending the appropriate signal over the USER I/O cable. If any MINV units is "off", the remaining systems will maintain their outputs. If any MINV cannot deliver output power because it cannot draw power from its DC INPUT, or because there is an internal fault, all of the MINV units will stay active.

### Redundant Paralleling -R Option

The “R” option adds an electronic breaker to the AC output of the MINV to provide fault-tolerant, glitch-free parallel operation. Should one unit experience a fault that could otherwise cause the AC output to collapse, the breaker disconnects the failed unit from the AC bus. This allows the remaining units to continue delivering power, provided the remaining units can support the total load power. This allows users to create N+1 or N+M redundant systems.

These units can be arranged to form single-phase, Split Phase, and 3-Phase systems. Systems with multiple phases will be N+1 or N+M redundant on each phase.

A failed unit can be removed and replaced while the system AC output is active. Special consideration must be taken when connecting the outputs to avoid electric shock. It is strongly recommended that the system AC output be disabled before a unit is removed or replaced.

CONFIGURATION cables for two unit and three unit single-phase systems are offered as standard products. See the following pages for details. Contact the SynQor factory for Single Phase systems larger than 3 MINV units, or for Split Phase and 3-Phase systems.

Systems created using expanded parallel MINV units will be fault-tolerant to the following events:

- Complete loss of power source (DC INPUT)
- Hardware failure of the AC output stage

The enable and disable behavior of systems using expanded paralleling is the same as systems using standard paralleling; all MINV units will be enabled if one MINV is enabled. Units can be enabled by actuating the front-panel “on” switches or by sending the appropriate signal over the USER I/O cable.

Sending a “OUTPUT DISABLE” command to a MINV will cause only that MINV to be disabled. Other MINV units in the system will continue running. Sending a “SYSTEM DISABLE” command over the RS-232 interface will cause all MINV units in a system to turn off simultaneously.

For a detailed description of the terminal interface see the SynQor website at:

[https://www.SynQor.com/MINV/documents/MINV\\_User\\_Commands.pdf](https://www.SynQor.com/MINV/documents/MINV_User_Commands.pdf)

Possible configurations of the AC OUTPUTS

Multi-unit Configurations

The chart below shows four possible ways the AC OUTPUTS of multiple SynQor MINV units can be connected together. Each configuration will be discussed in more detail in the following pages.

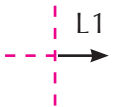
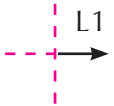
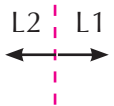
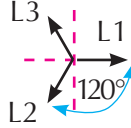
Number of MINV Units	Output Configuration	Phasor Diagram	# of Output Phases	Output Voltage	Output Current per phase	Total Output Power	Configuration Cable
2	Parallel		1	L-N: $1 \times V_{rated}$	$2 \times I_{rated}$	$2 \times P_{rated}$	SYN-9341
3	Parallel		1	L-N: $1 \times V_{rated}$	$3 \times I_{rated}$	$3 \times P_{rated}$	SYN-9343
2	Series Split-Phase		2	L-N: $1 \times V_{rated}$ L-L: $2 \times V_{rated}$	$1 \times I_{rated}$	$2 \times P_{rated}$	SYN-9613
3	3 Phase-Y		3	L-N: $1 \times V_{rated}$ L-L: $1.73 \times V_{rated}$	$1 \times I_{rated}$	$3 \times P_{rated}$	SYN-9617

Note that the chart shows the SynQor part number for the CONFIGURATION cable required for each configuration.

The chart shown above focuses on how the AC OUTPUTS of multiple MINV units could be connected. Of course, there are multiple ways in which the DC INPUT could be connected, as well. The DC INPUT could be connected to the same source, or it could be connected to separate sources. The possibilities will be discussed at the end of this section.

When ordering, select the “F: Floating” or “R: Redundant” option for MINV units configured in this manner.

Contact the SynQor factory for redundant Split Phase systems, redundant 3-Phase systems, or redundant Single Phase systems with more than three units.

**Parallel Connection of the AC Outputs**

Two or three SynQor MINV units can have their AC OUTPUTs connected in parallel to deliver two or three time the output power and output current of a single unit. Units can also be connected to form 1+1 or 2+1 redundant systems.

**Two MINV units with AC OUTPUTs Paralleled**

For two MINV units having their outputs connected in expanded parallel or redundant parallel, the wiring diagram for the AC OUTPUT cables and the CONFIGURATION cable is shown below:

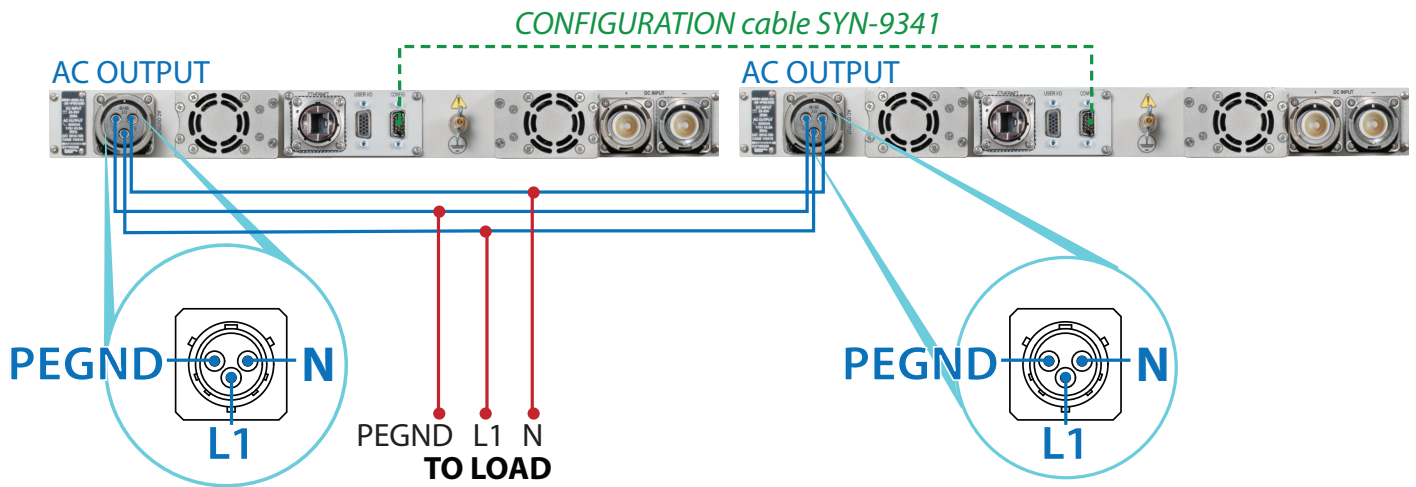

When ordering, select the “F: Floating” or “R: AC Output Electronic Breaker” option for MINV units configured in this manner.

If the user is providing the AC OUTPUT cable, the cable sections shown above in either blue or in red should have the following minimum wire size.

MINV AC Output Voltage	Blue Cable Section Minimum Wire Size	Red Cable Section Minimum Wire Size
115 Vac	#8AWG (10 mm <sup>2</sup> )	#2AWG (41 mm <sup>2</sup> )
230 Vac	#10AWG (6 mm <sup>2</sup> )	#6AWG (16 mm <sup>2</sup> )

**Three MINV units with AC OUTPUTs Paralleled**

For three MINV units having their outputs connected in expanded parallel or redundant parallel, the wiring diagram for the AC OUTPUT cables and the CONFIGURATION cable is shown below:

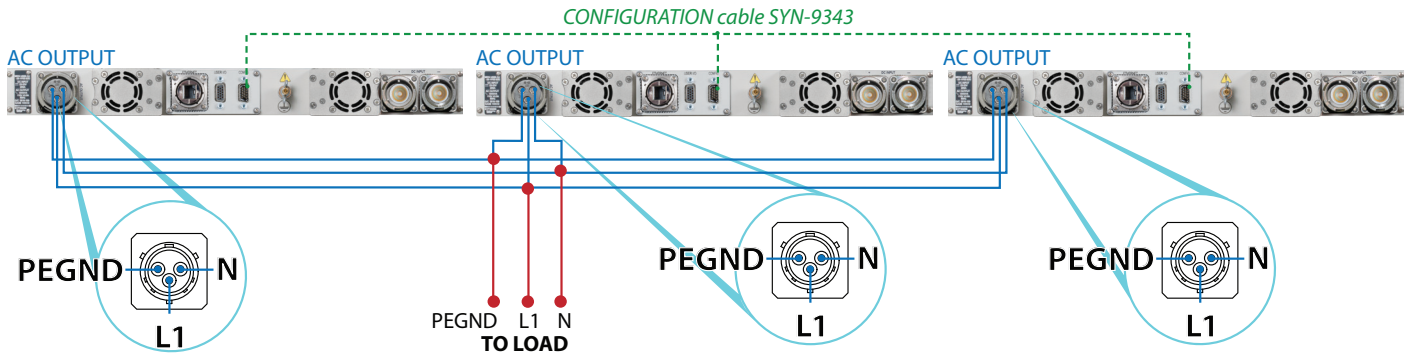

When ordering, select the “F: Floating” or “R: AC Output Electronic Breaker” option for MINV units configured in this manner.

If the user is providing the AC OUTPUT cable, the cable sections shown above in either blue or in red should have the following minimum wire size, depending on whether the AC OUTPUT of the MINV units is 115 Vac or 230 Vac.

MINV AC Output Voltage	Blue Cable Section Minimum Wire Size	Red Cable Section Minimum Wire Size
115 Vac	#8AWG (10 mm <sup>2</sup> )	#0AWG (65 mm <sup>2</sup> )
230 Vac	#10AWG (6 mm <sup>2</sup> )	#4AWG (26 mm <sup>2</sup> )

**Series Split-Phase Connection of AC Outputs**

Two MINV units can have their AC OUTPUTs connected in series to create an output voltage that is twice that of the output voltage of the individual MINV units. For instance, if the MINV units each create a 115 Vac output, the series configuration will create a 230 Vac output at twice the power level of a single unit. Or, if the MINV units each create a 230 Vac output, the series configuration will create a 460 Vac output at twice the power level of a single unit.

The center node between the two outputs in the series configuration should be considered the “neutral” wire, and therefore kept at a potential close to Protective Earth Ground (PEGND).

The other two AC OUTPUT wires (one from each MINV unit) are electrically “hot” (meaning at a high potential relative to the neutral or PEGND). One will be phase- shifted by 180 degrees (one-half cycle) from the other, meaning that when one hot wire is at its positive peak the other is at its negative peak, and vice versa. The voltage between these two hot wires is therefore twice that of either hot wire compared to the neutral wire. This configuration is called “Split-Phase”. When ordering, select the “F: Floating” option for MINV units configured in this manner.

Contact the SynQor factory for N+1 redundant Split Phase systems.

The wiring diagram for the AC OUTPUT cables and the CONFIGURATION cable for the Split-Phase configuration is shown below:

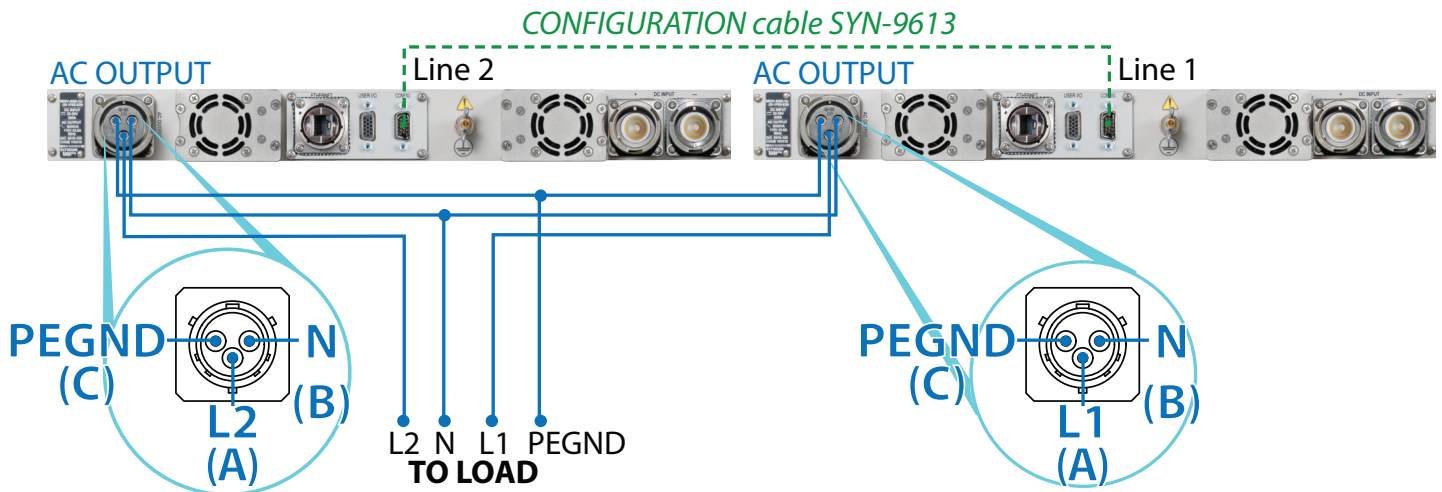

If the user is providing the AC OUTPUT cable, all the cable sections should have the following minimum wire size, depending on whether the AC OUTPUT of the individual MINV units is 115 Vac or 230 Vac.

MINV AC Output Voltage	Cable Minimum Wire Size
115 Vac	#8AWG (10 mm <sup>2</sup> )
230 Vac	#10AWG (6 mm <sup>2</sup> )

**Series 3-Phase Connection of AC Outputs**

Three MINV units can have their AC OUTPUTs connected such that they share a common “neutral” and then controlled such that their output voltages are phased by 120 degrees (one-third cycle) from each other. This creates a three-phase output where the line-to-neutral voltage is the rated voltage of the individual MINV units (e.g. 115 Vac or 230 Vac line-to-neutral) and the line-to-line voltage is 1.73 times higher (e.g. 200 Vac or 400 Vac line-to-line). When ordering, select the “F: Floating” option for MINV units configured in this manner.

Contact the SynQor factory for N+1 redundant 3-Phase systems.

The wiring diagram for the AC OUTPUT cables and the CONFIGURATION cables for the 3-Phase configuration is shown below:

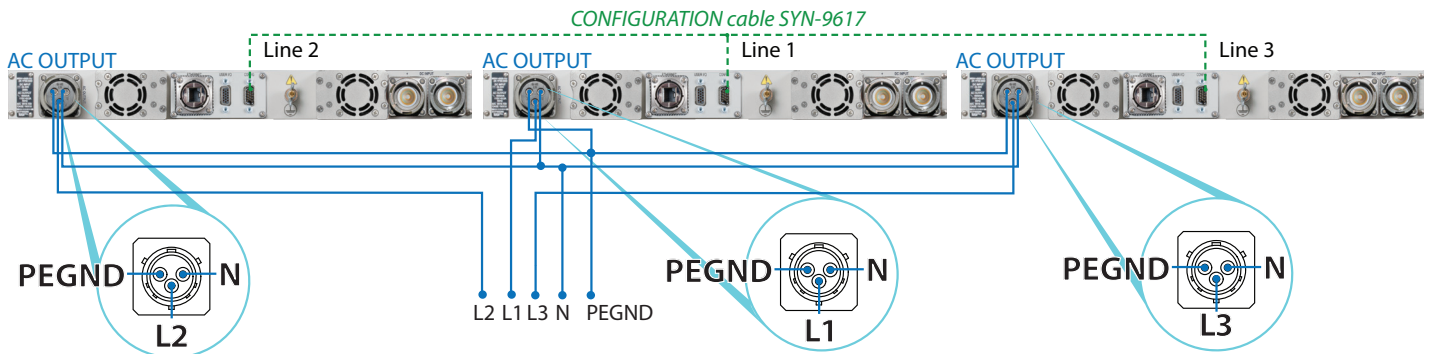

If the user is providing the AC OUTPUT cable, all the cable sections should have the following minimum wire size, depending on whether the AC OUTPUT of the individual MINV units is 115 Vac or 230 Vac.

MINV AC Output Voltage	Cable Minimum Wire Size
115 Vac	#8AWG (10 mm <sup>2</sup> )
230 Vac	#10AWG (6 mm <sup>2</sup> )

The “neutral” wire of the 3-Phase AC OUTPUT should be kept at a potential close to Protective Earth Ground (PEGND).

**Note:** The three connectors of the SYN-9617 CONFIGURATION CABLE are labeled “Line 1”, “Line 2” and “Line 3”. The MINV unit that receives the “Line 1” connector will have an AC OUTPUT that is phased 120 degrees (one-third cycle) ahead of the MINV unit that receives the “Line 2” connector, which in turn will have an AC OUTPUT that is phased 120 degrees (one-third cycle) ahead of the MINV unit that receives the “Line 3” connector. Connecting the three AC OUTPUTs to the three line wires of the AC OUTPUT cable in the proper order may be important for some loads, such as motors.

### *Parallel Configurations of the AC OUTPUTS: Up to 32 Units*

The “F” or “R” options allow up to 32 MINV units to be placed in parallel in Single-Phase, Split-Phase and 3-Phase configurations. The “R” option adds a single pole, electronic breaker to the hot wire of the AC OUTPUT. This breaker allows for fault-tolerant, glitch-free operation of up to 32 MINV units in a multi-unit system. Single phase, Split-Phase , and 3-Phase systems can be formed. These systems can be N+1 or N+M redundant on each phase.

The figures below show the different system configurations that can be formed with “F” or “R” option units. Each system requires its own unique CONFIGURATION cable. Contact the SynQor factory to purchase system specific configuration cables. Note that configuration cables for two unit and three unit Single-Phase systems are offered as standard products. See the previous pages for part numbers.

**Single Phase Output System**

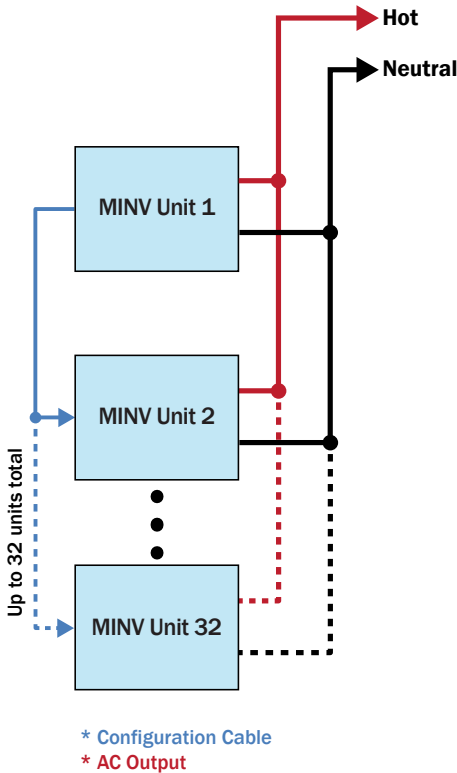

**Split Phase Output System**

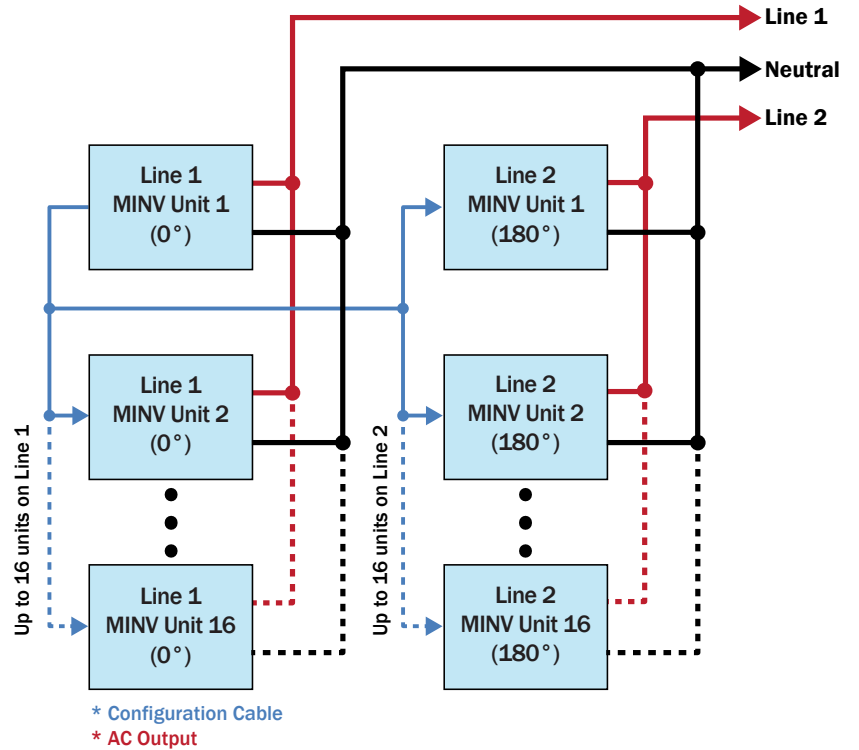

**3-Phase Output System  
(Wye - Connection Only)**

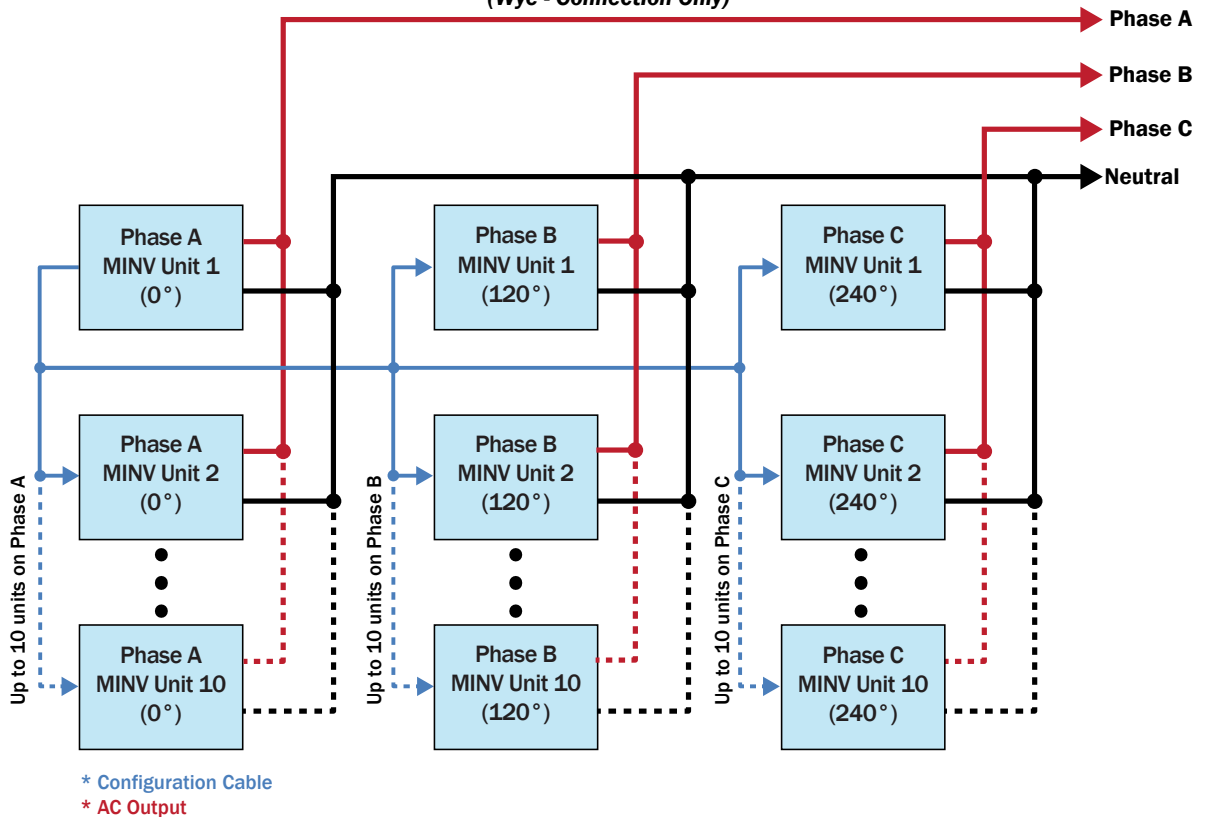

### Connection of the DC INPUTS

Whether there are two or three MINV units in the multiple-unit configuration, there are several ways that the DC INPUTS can be connected to sources of power:

- They could be connected to the same DC source.
- They could be connected to different DC sources.

All that is necessary is to ensure that the input voltage falls within the specified range of the DC INPUTS of the individual MINV units.

Furthermore, the individual DC INPUT cables can be first combined into a single cable (of appropriate minimum wire size), or they can be left as separate cables, each connected to the desired DC source.

### Multi-Unit AC OUTPUT On/Off Control – Expanded/Redundant Parallel (-F/-R option)

In multi-unit operation, a single front panel “on” switch actuation, “remote-on” rear panel signal input, or *OUTPUT ENABLE* serial command will cause all MINV devices to enable their outputs. Redundant parallel units (“R” option) come with a floating neutral wire by default. Any “off” front panel switch actuation, “remote-off”, or *OUTPUT DISABLE* serial command will only disable that specific MINV. Sending the *SYSTEM DISABLE* serial command to any MINV system in a multi-unit configuration will cause a coordinated shutdown of all AC OUTPUTs. If any single MINV no longer has a valid input power source (e.g., no DC input), it will shut down while the AC OUTPUTs of the remaining systems stay active.

### AC OUTPUT Neutral Grounding

MINV units combined in multi-unit configurations must have the neutral floating “F” factory option to prevent the possibility of circulation protective earth currents. Redundant parallel units (“R” option) come with a floating neutral wire by default. If a grounded output neutral is required, then the output neutral should be connected to protective earth ground (PEGND) in one spot. The size of the neutral-to-PEGND connecting conductor must be sized to match the largest combined AC output neutral conductor specified in the following wiring diagrams.

### Wiring Caution

**WARNING:** LETHAL VOLTAGES MAY BE PRESENT ON MINV AC OUTPUT CONNECTIONS. ALL AC OUTPUT CABLE CONNECTORS MUST BE INSTALLED DURING OPERATION AS A DISCONNECTED CABLE CONNECTOR MAY HAVE EXPOSED VOLTAGE PRESENT FROM ANOTHER UNIT IN THE GROUP.

### Control Cable Connections

There are two high-density (three-row) DB15 connectors located on the rear panel of the MINV:

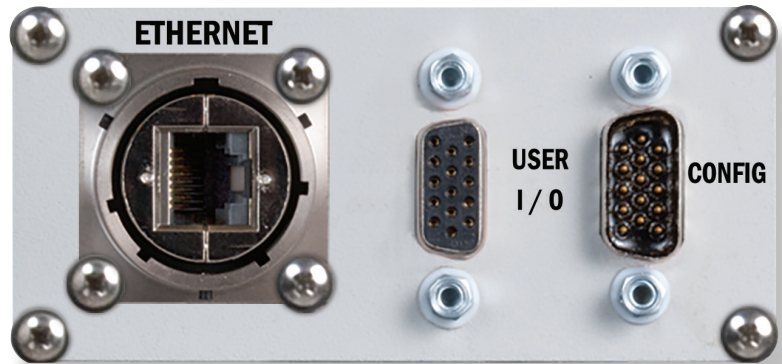

The User I/O female DB15 connector on the left is for a connection to a host/system computer so that it can control the MINV and receive information regarding the status of the MINV.

The Configuration male DB15 connector on the right provides for synchronized startup and shutdown operation of multiple interconnected units. See the “Possible configurations of the AC OUTPUTS” on page page 25 for supported configurations and the “Synchronized Operation of Multiple Units” on page page 38 for details.

The designation/location of the pins for the User I/O female high-density DB15 connector is shown below:



**Internal User I/O Circuits**

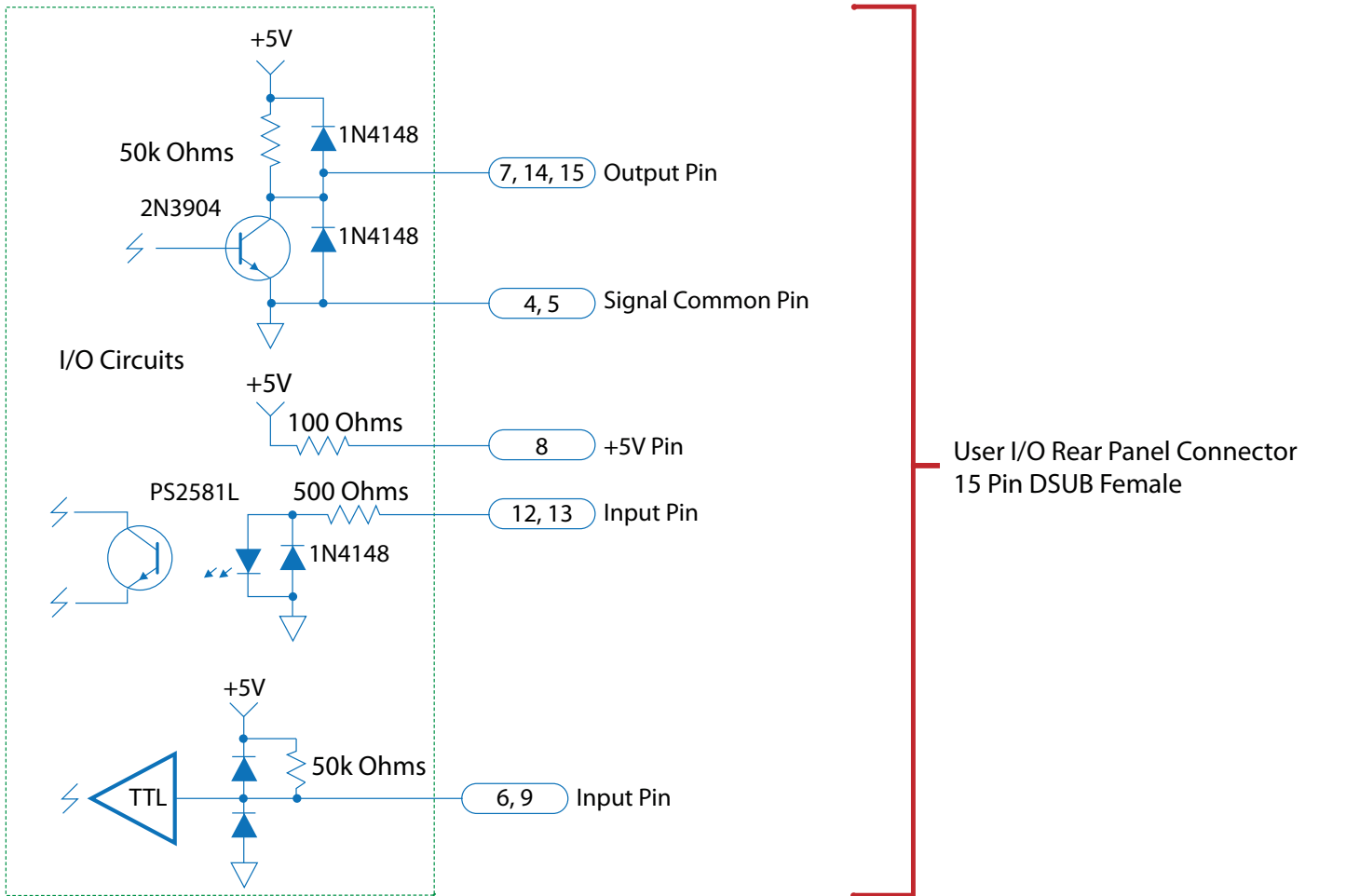

**Remote On/Off Switch Connections**

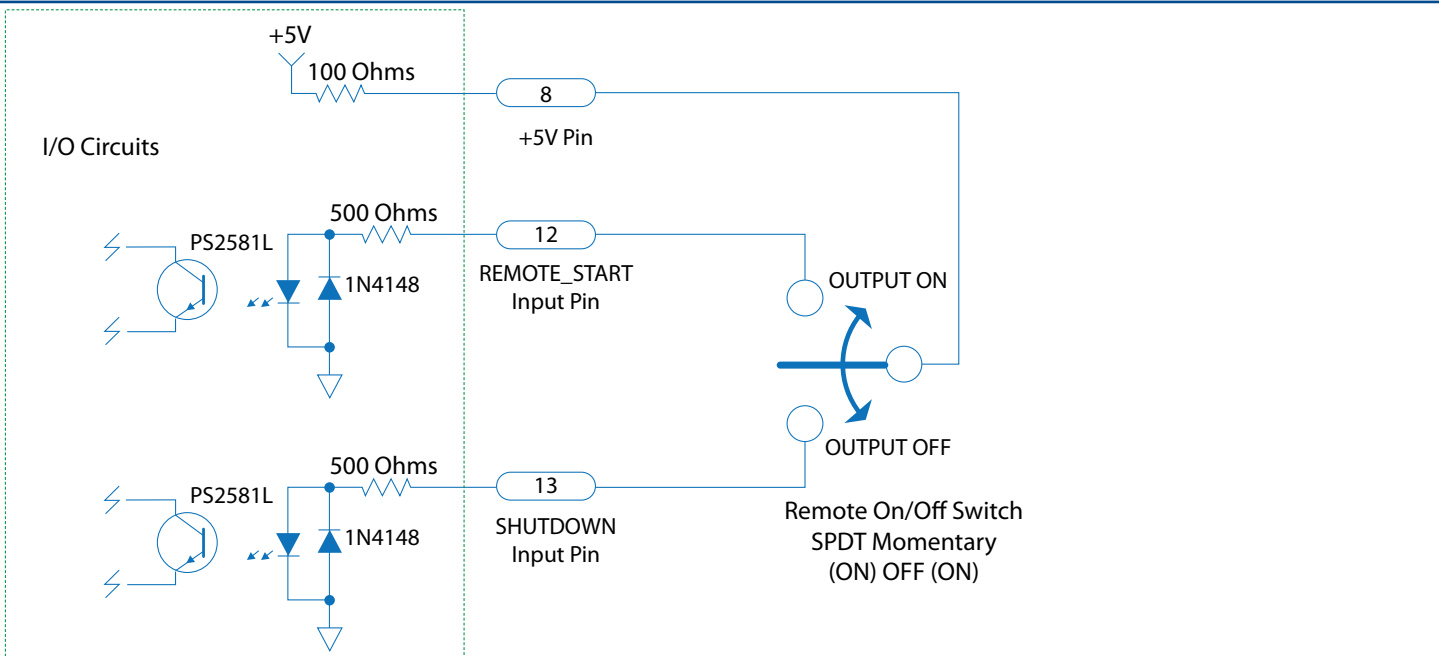

Note: A 2PDT or 3PDT switch may be substituted for single control of 2 or 3 MINV machines, respectively.

### Digital Input/Output Control Signals

There are 3 input and 4 output digital signals available on the User I/O female high-density DB15 connector. The pin assignments and functions of these digital I/O signals are as follows:

#### High Density DB15 Female (15 Pin Connector)

Signal	PIN	Function
TX	2	RS232 DCE Device Transmit
RX	3	RS232 DCE Device Receive
GND	4, 5	Ground reference for all digital inputs and outputs
BATTLE_MODE	6	TTL-Input*, pull "low" to engage Battle Mode to disable internal over temperature protection, has internal pull-up to +5 V.
DCIN_GOOD	7	Open collector* output where "low" indicates DC Input voltage is within range
+5 V	8	Vout with minimal current drive usable as a pull-up voltage for open collector output signals. Load must be < 35 mA
BLACKOUT_MODE	9	TTL-Input*, pull "low" to engage Blackout Mode to disable front-panel LEDs and audible alarms, has internal pull-up to +5 V.
REMOTE_START	12	Drive this line "high" with $\geq 5$ mA to enable MINV outputs
SHUTDOWN	13	Drive this line "high" with $\geq 5$ mA to disable MINV outputs
OUT_OK	14	Open collector* output where "low" indicates AC Output voltage is within range
OVER_TEMP	15	Open collector* output where "low" indicates that the MINV is at or above its maximum temperature

\*With an internal 50 k Pull-up Resistor to 5 V and ESD Protection Diodes.

Battle Mode disables internal over-temperature shutdown limits in the MINV hardware. Battle Mode is indicated with a flashing red light in panel position E2. This mode can be commanded by pulling low on I/O Port Pin 6, or via serial command *BS ON*.

Blackout Mode disables all visual and audible indication of system status. Front-panel LEDs and audible alarms will be turned off. This mode can be commanded by pulling low on I/O Port Pin 9, or via serial command *BLACKOUT ON*.

### RS232 Serial Interface

The same User I/O female high-density DB15 connector also provides for an RS232 interface between the MINV and the host/system computer. The interface has a 115.2k baud with eight data bits, no parity bit and one stop bit. The pin assignments and functions for this RS232 interface are as follows:

Signal	Pin Number	Function
GND	4 and 5	Ground reference for RX and TX signals
RX	3	RS232 DCE/MINV Device Receive signal
TX	2	RS232 DCE/MINV Device Transmit signal

The RS232 port provides readback of MINV's state, as well as the configuration and control of the MINV's operation. The port can be used from a standard terminal interface, or from a custom computer application.

#### ***Readback information that is available:***

- DC Input Voltage
- AC Output Voltage
- AC Output Current
- AC Output Power
- AC Output Frequency
- Total Output Power
- External Switch Input Status
- Fan RPM
- Internal Temperatures

#### ***Parameters that are controllable through the interface:***

- Battle Mode
- Blackout Mode
- Alarm enable / disable
- Fan diagnostics
- On/Off Synchronization
- Output enable / disable
- Sleep Mode enable / disable

For a detailed description of the terminal interface see the SynQor website at:  
[https://www.SynQor.com/MINV/documents/MINV\\_User\\_Commands.pdf](https://www.SynQor.com/MINV/documents/MINV_User_Commands.pdf)

## Ethernet Interface

The Ethernet interface provides a web page based user interface for monitoring and control of the MINV. The user can configure email alerts for MINV alarm conditions. The interface also exposes an SNMP interface compliant to RFC-1628.

The Ethernet interface supports 10BASE-T and 100BASE-T standards. It utilizes a standard RJ-45 connector, also allowing a metallic sealable circular military outer housing. The interface supports auto-negotiation, polarity correction, and Auto-MDIX (detection and use of straight through or cross-over cables).

IP address assignment can be done via DHCP or user entry of a static address. The interface also supports a direct connection between the MINV and a host computer by including a DHCP server internal to the MINV.

For a detailed description of the Ethernet port and SNMP implementation see the SynQor website at: [https://www.synqor.com/MINV/documents/MINV\\_Ethernet\\_SNMP\\_UG.pdf](https://www.synqor.com/MINV/documents/MINV_Ethernet_SNMP_UG.pdf)

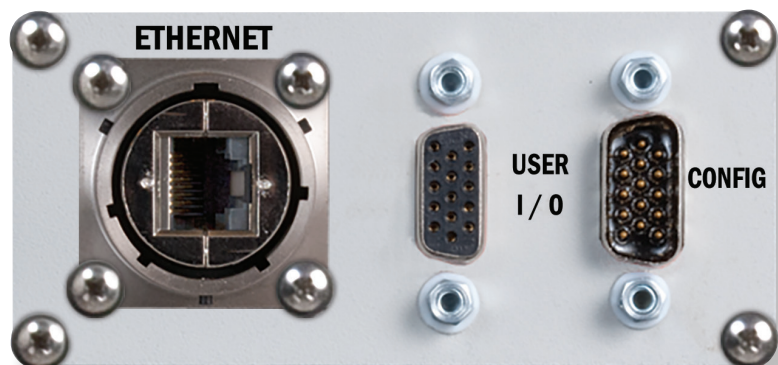

### ***Synchronized Operation of Multiple Units***

Interconnecting multiple units via the Configuration port using the various CONFIGURATION cables enables synchronized start-up and shutdown of connected units.

---

#### ***Turn-On, Turn-Off, Restart Control:***

---

When a MINV device is in the Standby Mode (input power applied but output not enabled), and its output is enabled via the front panel switch, remote enable input, or serial command, all other MINV devices that are also in the Standby Mode will enable their outputs at the same time. This feature is enabled by default when the CONFIGURATION cables are utilized to interconnect multiple MINV devices. This feature can be disabled via the serial interface using the *SYNCCON OFF* command, and this setting is stored in non-volatile memory. This feature can also be disabled via the web interface.

When a unit is operating and its output is running, if its output is disabled via the front panel switch, remote shutdown input, or serial command, all other MINV devices that are operating will remain enabled, if those remaining MINV devices can support the present load. The *SYSTEM DISABLE* command will allow a synchronized shutdown of all MINV outputs.

## Sleep Mode

The SynQor MINV-4000 features a user-configurable sleep mode option. Enabled by default, the sleep mode allows the system to enter an extremely low-power state while powered from the DC INPUT.

The sleep mode forces the system to disable all internal circuitry after being in the standby state for one minute. Additionally, upon initial application of DC INPUT power, the system will enter the sleep state.

While in the sleep state, the total system input current will be reduced to less than 500  $\mu$ A. In order to wake the system, the front panel switch needs to be held in the UP position.

To disable the sleep mode, the *SLEEP DISABLE* command must be transmitted. The sleep mode can be re-enabled by transmitting the *SLEEP ENABLE* command.

## Fans

The fans on the rear panel have sealed bearings that do not require any maintenance. Fan assemblies are user replaceable with kits available from SynQor. Please contact the SynQor factory for obtaining fan replacement kits (Counter-Rotating Replaceable Fan Module SYN-9452).

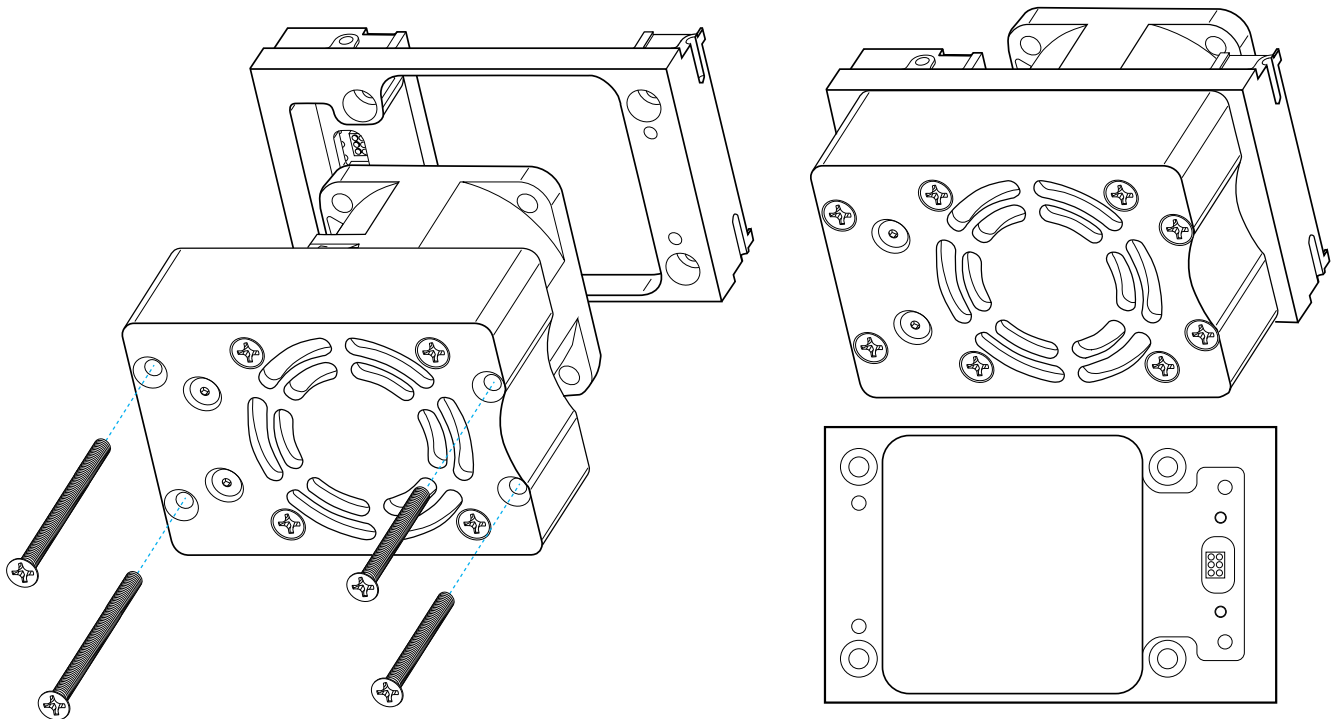

## Cleaning

The MINV-4000 unit has a sealed chamber for its electronics that is weather-proof. Only the fans on the rear panel are exposed to the environment, and these fans are also weather-proof. The unit can therefore be cleaned without concern of getting liquids inside the chamber. **NOTE**, however, that if the cables have been removed from the connectors the connectors should have their covers installed. If they are not, then care should be taken to not get excess liquid on the connector terminals. **ALSO NOTE** that care should be taken to not get excess liquid on the switch of the AC BREAKER on the back panel.

Cleaning should be done either with soap and water or with an Isopropyl alcohol and water mixture. A soft cloth should be used.

Do not immerse the unit in water to clean it.

**Fault Conditions**

The SynQor MINV has no user-serviceable parts within it. If it has an internal malfunction only factory trained personnel should attempt to repair it.

There are, however, several external conditions that could cause the MINV to not operate as desired. These external conditions can likely be corrected by the user.

The 11 LEDs on the front panel are the best and first place to look to determine what might be wrong with the MINV. The table on the next several pages is therefore organized by what these LEDs indicate, and for each indication there is a listing of what might possibly be wrong.

The front panel LED array is shown below. The designations of the 11 LEDs in this array are used in the following table.

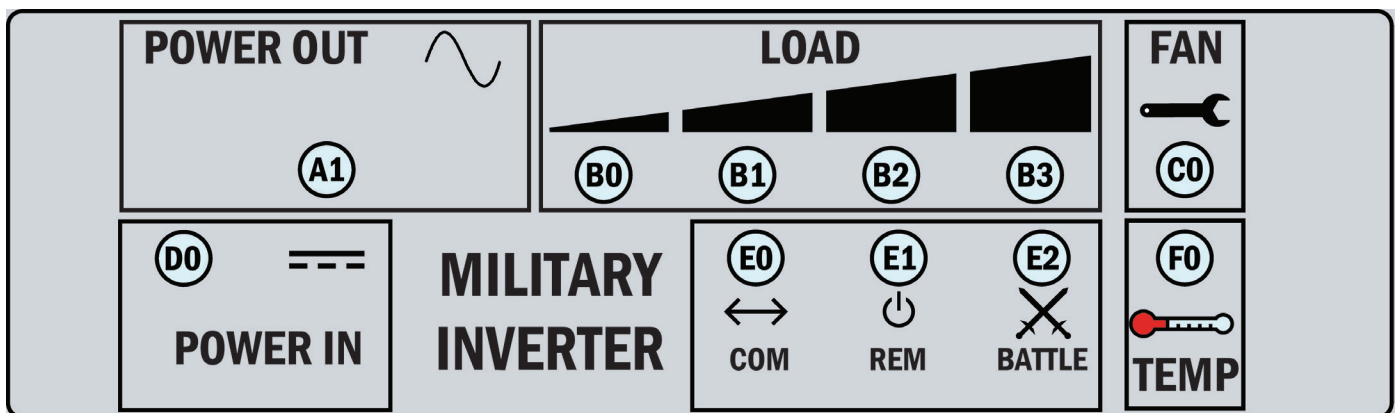

LED	Indication	Possible Problem(s)
<b>D0:</b> DC INPUT Power LED	LED is OFF	<ul style="list-style-type: none"> <li>•The DC INPUT power source is not turned on.</li> <li>•The DC INPUT cable is not connected or it is wired wrong.</li> <li>•The MINV is OFF and needs to be turned ON.</li> </ul>
	LED is AMBER	<ul style="list-style-type: none"> <li>•The DC INPUT voltage is either too low or too high.</li> </ul>
	LED is RED	<ul style="list-style-type: none"> <li>•The DC INPUT voltage is missing at least one phase on its source.</li> </ul>
<b>A1:</b> AC OUTPUT Power LED	LED is OFF	<ul style="list-style-type: none"> <li>•The MINV is OFF and needs to be turned ON.</li> </ul>
	LED is AMBER	<ul style="list-style-type: none"> <li>•The AC OUTPUT load is higher than 4000W or 5000VA by enough to trigger the power limit circuitry.</li> <li>•The AC OUTPUT load crest factor is too high.</li> <li>•The AC OUTPUT is shorted within the cable or a load.</li> <li>•Some other source of power is connected to the AC OUTPUT.</li> </ul>
	LED is RED	<ul style="list-style-type: none"> <li>•The MINV has been turned OFF, but due to a malfunction within the MINV it is still running and providing an AC OUTPUT voltage.</li> <li>•Some other source of voltage is connected to the AC OUTPUT and is powering it when the MINV is disabled.</li> </ul>

LED	Indication	Possible Problem(s)
<b>B0 – B3: LOAD POWER LEDs</b>	B3 is BLINKING RED	<ul style="list-style-type: none"> <li>•Total MINV load power is greater than or approaching 4000W. The MINV may still be delivering its specified output voltage because the load power is not high enough to trigger the power limit circuitry.</li> </ul>
	B0 – B3 are all OFF	<ul style="list-style-type: none"> <li>•No power is being delivered to the load.</li> <li>•The MINV is OFF and needs to be turned ON.</li> <li>•The loads or output cables are not connected.</li> <li>•The loads are all turned off.</li> <li>•The loads are simply not drawing any appreciable power at the time.</li> </ul>
<b>C0: Fan Service Required LED</b>	LED is AMBER	<ul style="list-style-type: none"> <li>•One or both fans have recently had degraded performance but seem to be ok now. The MINV is running a diagnostic test.</li> </ul>
	LED is RED	<ul style="list-style-type: none"> <li>•One or both fans presently have degraded performance, even if they are running, and service is recommended at the earliest convenient time.</li> <li>•Ensure that the fan blades are not obstructed from turning</li> </ul>
<b>F0: MINV Cooling System LED</b>	LED is BLINKING GREEN	<ul style="list-style-type: none"> <li>•Indicates that the fans are running at 50% of their rated speed. There is no problem.</li> </ul>
	LED is AMBER	<ul style="list-style-type: none"> <li>•Indicates that the fans are running at 75% of their rated speed. There is no problem, but the unit is operating at a high ambient temperature and a high load combination.</li> </ul>
	LED is RED	<ul style="list-style-type: none"> <li>•Fans are running at 100% of rated speed to keep the unit cool. The maximum recommended temperature may be exceeded, but the fans are keeping things cool enough to avoid triggering the over-temperature shut-down circuitry.</li> </ul>
	LED is BLINKING RED	<ul style="list-style-type: none"> <li>•The maximum recommended temperature has been exceeded and the system is approaching over-temperature protection. The load and / or ambient temperature should be reduced if possible.</li> </ul>
<b>All LEDs:</b>	All LEDs are OFF	<ul style="list-style-type: none"> <li>•The MINV is OFF and needs to be turned ON.</li> <li>•The DC INPUT power is not turned ON.</li> </ul>
<b>Audible Alarm: (pattern repeats every 5 seconds)</b>	One tone	<ul style="list-style-type: none"> <li>•The DC INPUT voltage is lower than the minimum operating level.</li> <li>•Raise the DC INPUT voltage above the minimum level or verify the wiring is appropriate for the input current so as not to cause an excessive voltage drop.</li> </ul>
	Two tones	<ul style="list-style-type: none"> <li>•The total MINV load power is above 4000 W.</li> <li>•Loads should be reduced if this condition persists.</li> </ul>
	Three tones	<ul style="list-style-type: none"> <li>•The AC OUTPUT has experienced either a short circuit or a load having a start-up surge current characteristic that the MINV could not start. The AC OUTPUT has therefore turned OFF.</li> <li>•To reset, the MINV must be turned OFF and then ON.</li> </ul>
	Four tones	<ul style="list-style-type: none"> <li>•One or more fans have encountered a fault or degraded performance.</li> <li>•The MINV may still operate with degraded fan performance, but will require service. Ensure the fan blades are not obstructed.</li> </ul>

***Two other conditions should be mentioned:*****• The fans are off when the MINV is running**

It is normal for the fans to be off, even if the MINV is running and delivering power to the load, as long as the temperature of the MINV is low enough. If the Fan Service Required LED (C0) is green, both of the fans are OK, even if they are not running.

**• The MINV does not turn off when the ON/OFF switch is pushed down**

When the ON/OFF switch on the front panel is pushed down, the MINV does not respond to this signal for approximately 1 second. This is done to ensure that the MINV is not accidentally turned off. If the user does not hold the ON/OFF switch in the OFF position for a full second before releasing it, the MINV will not turn off.

***Other possible situations that are the result of external issues that a user could likely correct are related to:*****• Cable wire resistance is too high:**

As mentioned in the section “Power Cable Wire Size,” the resistance of a power cable’s wires gives a voltage drop from the upstream to the downstream end of the cable. This voltage drop, if large enough, will cause the MINV to determine that the voltage at its DC INPUT is below its minimum specified value, even though the corresponding voltage at the source of DC power is within the specified range.

This problem is particularly possible for the MINV system, since the DC INPUT current is so high (as much as 240 A at full power) and the DC INPUT voltage is so low (as low as 20 V).

This phenomenon that may be displayed is the following:

- The MINV, before it turns on, does not draw any power or current from the DC INPUT, and therefore the voltage drop across the DC INPUT cable is zero.
- The MINV sees that the voltage at the DC INPUT is within its specified range, and enables its outputs.
- As the load then draws power, the MINV begins to draw current from the DC INPUT cable. This current causes a voltage drop to appear across the cable.
- If the voltage drop at the DC source is close to, but still above, its 20 V minimum, but the voltage drop across the cable is large enough for the voltage at the DC INPUT of the MINV to fall below 20 V, then the MINV may determine that the DC INPUT is out of range and shut down.
- Since the MINV no longer draws current from the DC INPUT, the voltage drop across the DC INPUT cable goes back to zero volts.

- After a while, the MINV decides the DC INPUT voltage is back within its proper range, and begins to draw a current from the DC INPUT.
- The cycle above repeats itself for a total of three times, at which point the MINV stops trying to draw power from the DC INPUT for one minute. After this one minute another set of 3 cycles are repeated, followed by another stop for one minute, and so on.

The solution to this problem is to make sure that the cable has wires of sufficient diameter, or “gauge” for the length of cable. The longer the cable, the bigger diameter the wire should have.

See the section “Power Cable Wire Size” for recommended cable wire sizes.

- **The MINV fails to operate through an input voltage step**

When performing an input voltage step, it should be taken into consideration that the operation of the MINV-4000 may be affected. If the input voltage is being stepped down to no less than 20 V, the full 4000 W load can be provided by the MINV-4000 without concern for system operation. However, if the input voltage is being stepped down to less than 20 V, the MINV-4000 may exhibit undesired performance.

Instantaneously stepping the input voltage from greater than 28 V to less than 20 V may cause the MINV-4000 to detect a fault and shut down its output. Under this same step-down condition, the MINV-4000 may continue to operate but with an increase in input ripple current until the input voltage is raised above 18.5 V.

There are three ways to avoid a potential interruption in system operation when operating the MINV-4000 under this condition. They are as follows:

- Reduce the output power level to 3400 W or less, or
- Reduce the input cable length to 3 ft. or less, or
- Start with an input voltage that is less than or equal to 28 V

- **Loads that draw a large surge of current at start-up**

Some AC loads draw a very large amount of current when an input voltage is first applied to them. This might happen when the MINV is first turned on if the load is already connected to the MINV. Or it may happen when the load itself is turned on and/or connected to the AC OUTPUT of a MINV that is already running. Common examples of such loads are motors and incandescent lights, but some electronic equipment can also display this characteristic. Such loads can create various problems, including the following:

- 1) **The MINV fails to start the load:**

The SynQor MINV is designed to try various start-up routines when it is first turned on to overcome the problem of surge currents with some loads. There are five such routines (or repetitions of a given routine) that are tried. If the load is not started after these five routines are attempted, the MINV will turn OFF. To get the MINV to try again, the user should again push the ON/OFF switch on the front panel to the ON position.

If there is more than one load of the AC OUTPUT that displays this start-up surge characteristic, and the MINV is not capable of starting with all of them connected and switched on, it may be possible to switch on each load in turn. For instance, if the MINV cannot start up with a load consisting of a large bank of incandescent lights, then it may be able to start if various sections of the lights are switched on in sequence.

- 2) **A newly started load disturbs the existing MINV loads.**

A common problem can occur when the MINV is running and powering one or more loads connected to its AC OUTPUT, and then an additional load of the AC OUTPUT is turned on. If this newly started load draws a large surge current at start-up, it can cause the current limit of the MINV's AC OUTPUT to be triggered, and the AC OUTPUT voltage will then drop. This drop could cause the existing loads to be disturbed. Furthermore, if the voltage drops far enough, the MINV will turn off its AC OUTPUT and initiate a new start-up sequence (after 0.1 seconds.) This latter action would cause power flow to the existing loads to be interrupted.

If this disruption of existing loads is a problem, then the solution is to make sure the loads that display this start-up surge characteristic are all started first, or that all loads are started at the same time.

- **Powering the MINV through EMI filters or line impedance stabilization networks (LISNs)**

There are special usage conditions where the input source inductance may be too high for the MINV to function properly, such as when performing EMI compliance testing. The use of an EMI filter, LISN, or a long input power cable (> 25 m) where the total differential source inductance exceeds 30 uH will cause problems when load transients are applied to the MINV output, including normal start up into full load.

Commercial EMI filters designed for the MINV input voltage and current will generally not be a problem as the filter differential inductance will be < 30 uH. However, large EMI filters installed in commercial EMI test facilities that must work over a range of both AC and DC equipment, or LISN devices used for emission compliance testing, often have larger inductance. In extreme cases, such as full load transients with > 100 uH of source inductance, the MINV input may be damaged if no corrective measures are taken.

As a corrective measure, a capacitor may be placed directly across the MINV input. A suitable device for protection during EMI compliance testing is a 56 mF (56000 uF) 50 V aluminum electrolytic capacitor such as United Chemi-con CGS563U050X3L. The capacitor is placed between the MINV and the source inductance (e.g., LISN). Reverse polarity or voltages > 50 V must never be applied to this capacitor. It may also be necessary to increment the MINV output load in steps once enabled, thereby reducing the load transient magnitude.

# MINV **MILITARY FIELD-GRADE**

**MILITARY GRADE POWER INVERTER**

## Operator's Guide *MINV-4000-1U-28 Series*



**SynQor, Inc.**  
9 Northeastern Boulevard  
Suite 200  
Salem, NH 03079  
Phone: 1 (603) 541-4141  
E-mail: [power@synqor.com](mailto:power@synqor.com)  
[www.SynQor.com](http://www.SynQor.com)



Made in USA

**SynQor**  
Advancing The Power Curve®