



# Configurable Multi-Output DC-DC Power Supply

<b>1 Output</b> Standard Configuration	<b>16V to 40V</b> Continuous Operating Input	<b>Up to 1500W</b> Total Output Power	<b>90%-95%</b> Typical Efficiency
---	---	--	--------------------------------------

**Operation: -55° C to 100° C (at cold plate)**

The MultiQor Plate format of military-grade DC-DC power supplies provides one customer defined output voltage that is isolated from the input and the cold plate. Using SynQor's Mil-COTS line of high efficiency, high reliability, fixed switching frequency DC-DC converters, this supply is designed to comply with MIL-STD-704 for a 28Vin system when continuous full system power operation is only needed down to 16Vin. The complete assembly is designed to withstand the harsh environments of the Military and Aerospace industries and is compliant with MIL-STD-810G requirements.

## MultiQor™ DC-DC POWER SUPPLY

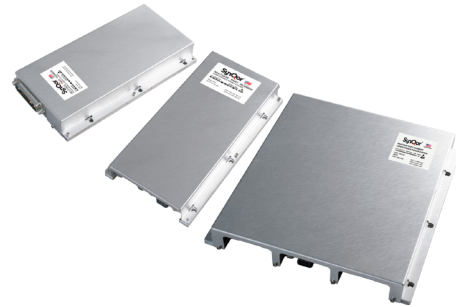

### OPERATIONAL FEATURES

- ◆ Designed to comply with MIL-STD-704 (A - F) Steady State
- ◆ High efficiency converters (90%-95%)
- ◆ Fixed frequency switching provides predictable EMI
- ◆ No minimum load requirement
- ◆ Soft start of all outputs

### CONTROL FEATURES

- ◆ System On/Off control (isolated)
- ◆ Output voltage Inhibit control (isolated)
- ◆ Remote Sense for the output voltage
- ◆ Output voltage trim available
- ◆ Input Good signal (isolated)

### MECHANICAL FEATURES

- ◆ Multiple physical formats
  - P1: 3.80" x 6.90" x 0.97" (Single output)
  - P2: 3.80" x 6.90" x 0.97" (Single output)
  - P3: 6.70" x 6.93" x 0.97" (Single output)
- ◆ Refer to mechanical diagrams for weight
- ◆ Cold plate with mounting holes for connection to heat removal system
- ◆ Cover

### OPTIONAL FEATURES

- ◆ Remote Sense Jumpers

### SAFETY FEATURES

- ◆ 1500Vdc @ 30 MΩ Input-to-output isolation
- ◆ Internal input fuse

### PROTECTION FEATURES

- ◆ Input under-voltage lockout
- ◆ Output current limit and short circuit protection
- ◆ Output over-voltage protection
- ◆ Thermal shutdown
- ◆ Automatic restart for all of the above
- ◆ Active back bias current limit

### CONTENTS

	Page No.
Configurations .....	2
Converters Listed by Vout.....	3
Block Diagrams.....	4
Family Input Characteristics.....	7
Family Charts .....	8
Qualifications Tests and Screening.....	9
Mechanical Drawings .....	10
Input Control Circuitry .....	14
Accessory Information .....	15
Ordering Information.....	16

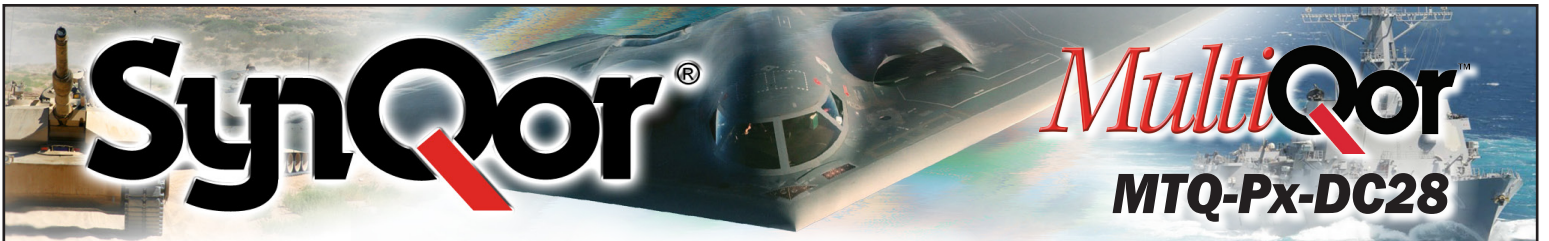

**MTQ-Px-DC28**

## CONFIGURATIONS

**P1**

### SINGLE OUTPUT

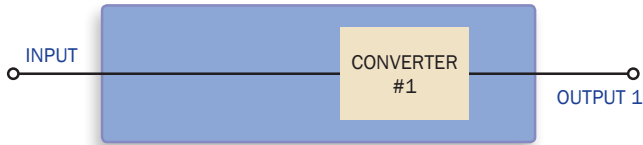

#### P1 DC-DC CONVERTER OPTIONS:

- Any Half-Brick converter from the MCOTS-28 Family
- Size: 3.80" x 6.90" x 0.97"
- Typical Weight: 1.2 LBS (1 HB)
- Mechanical Drawing P1

**P2**

### DUAL OUTPUT

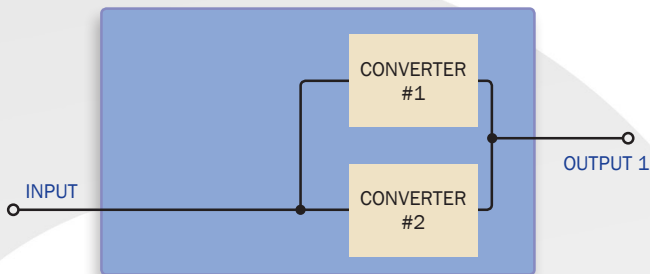

#### P2 DC-DC CONVERTER OPTIONS:

- Any Half-Brick converters from the MCOTS-28 Family
- Size: 3.80" x 6.90" x 0.97"
- Typical Weight: 1.3 LBS (2HB)
- Mechanical Drawing P2 - 2 Output Terminal  
(For Total Iout ≤ 60 A)
- Mechanical Drawing P2 - 4 Output Terminal  
(For Total Iout > 60 A)

**P3**

### TRIPLE OUTPUT

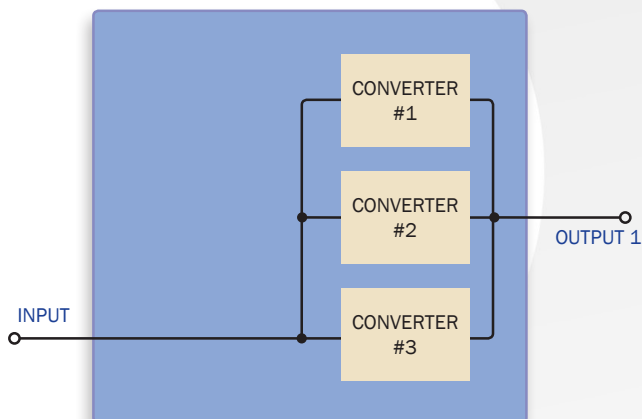

#### P3 DC-DC CONVERTER OPTIONS:

- Any Half-Brick converters from the MCOTS-28 Family
- Size: 6.70" x 6.93" x 0.97"
- Typical Weight: 2.5 LBS (3 HB)
- Mechanical Drawing P3



## Available MCOTS-28 DC-DC Converters

Half-Brick Zeta Series (MCOTS-C-28-xx-HZ)											
Vout	1.8	3.3	5.0*	7.0	12.0	15.0	24.0	28.0	40.0	48.0	50.0
Power†			300W		504W	510W	504W	504W			500W
Output Current‡			60A		42A	34A	21A	18A			10A
Efficiency @ Full Load (28Vin)			92%		94%	94%	93%	93%			94%
Ripple & Noise (28Vin, pk to pk)			135mV		100mV	100mV	250mV	100mV			250mV
Output OVP Setpoint (28Vin)			6.2V		14.8V	18.5V	29.5V	36.4V			—
No Load Input Current (28Vin)			290mA		310mA	340mA	300mA	340mA			340mA

Full system power operation at -55 °C to +100 °C, designed for Mil-COTS applications.

\* 5V output option does not require output power derating; full-power is available across the entire input range of 16-40Vin.

† Available output power is derated based on operating input voltage. See charts on page 8 for derating curves.

‡ Multiple output cables wired in parallel may be required depending on desired output current and configuration selected.

### BLOCK DIAGRAM FOR P1

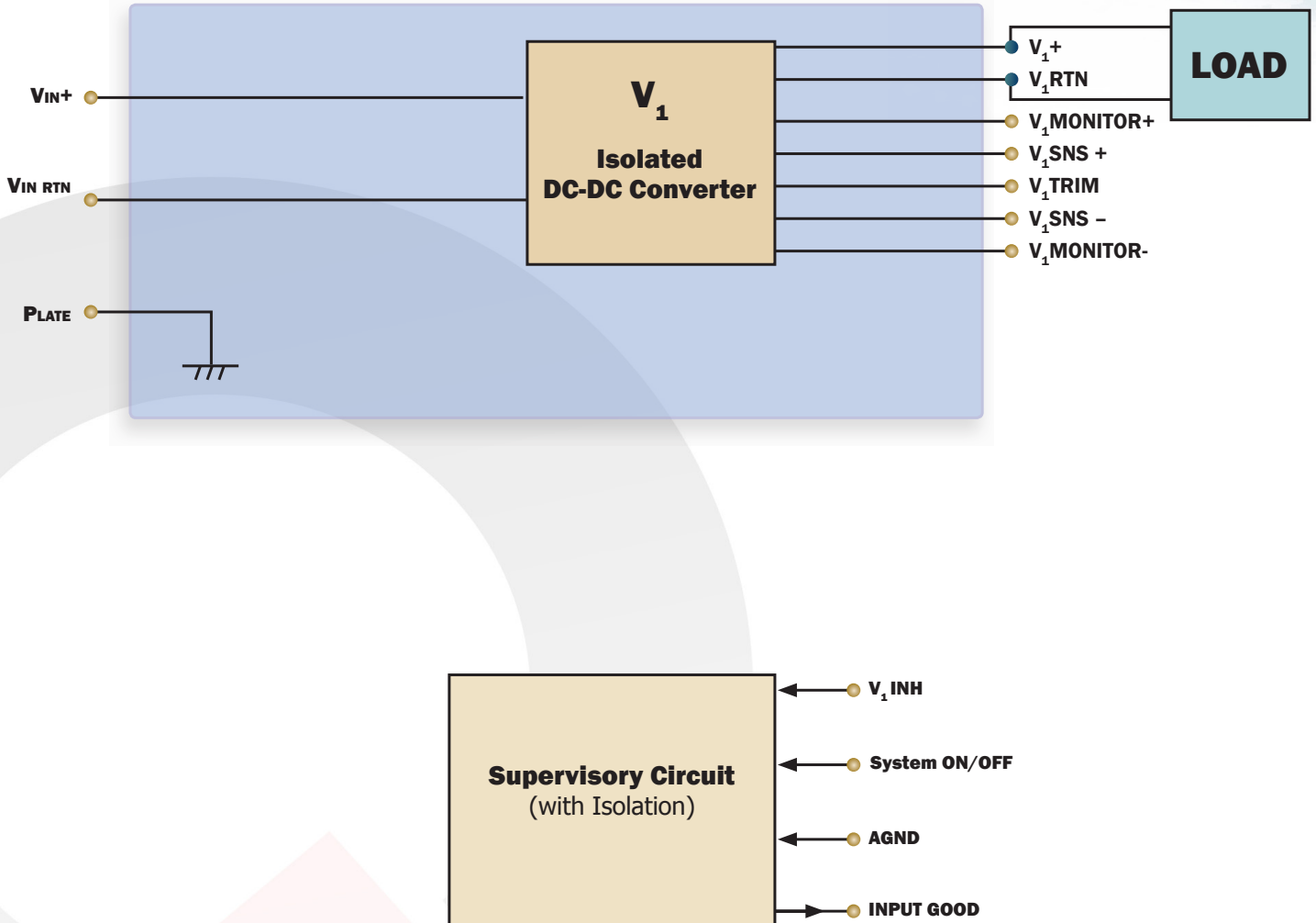

### BLOCK DIAGRAM FOR P2

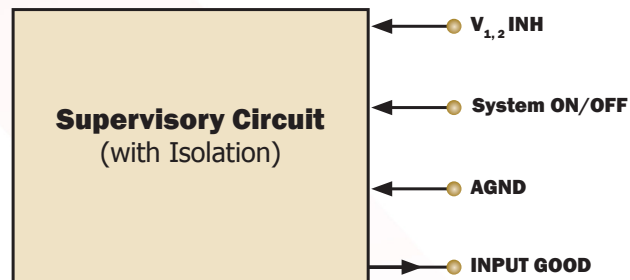
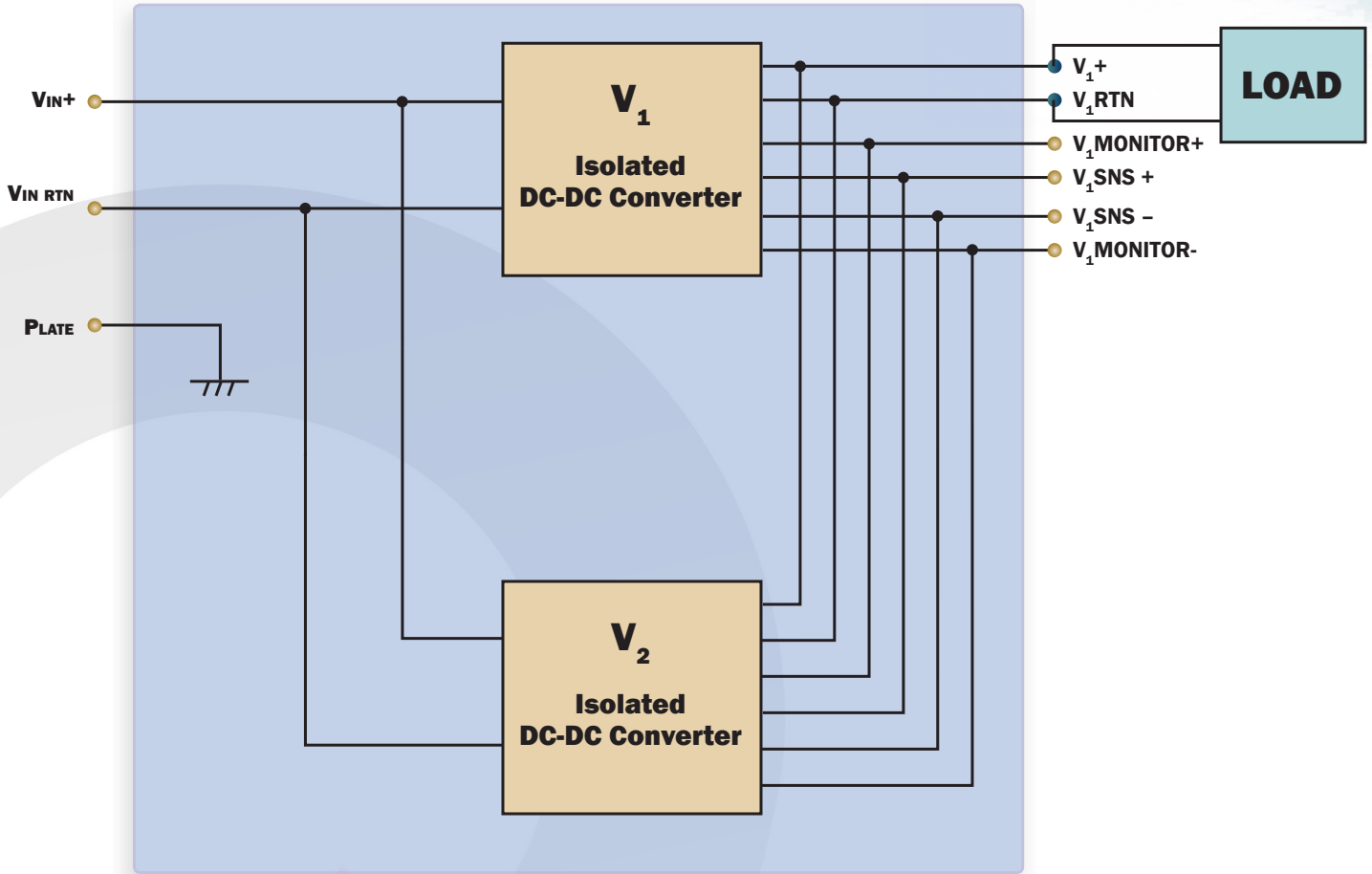

### BLOCK DIAGRAM FOR P3

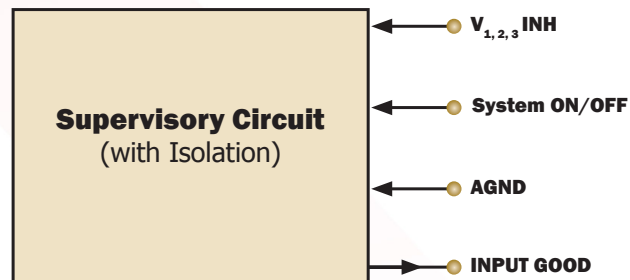
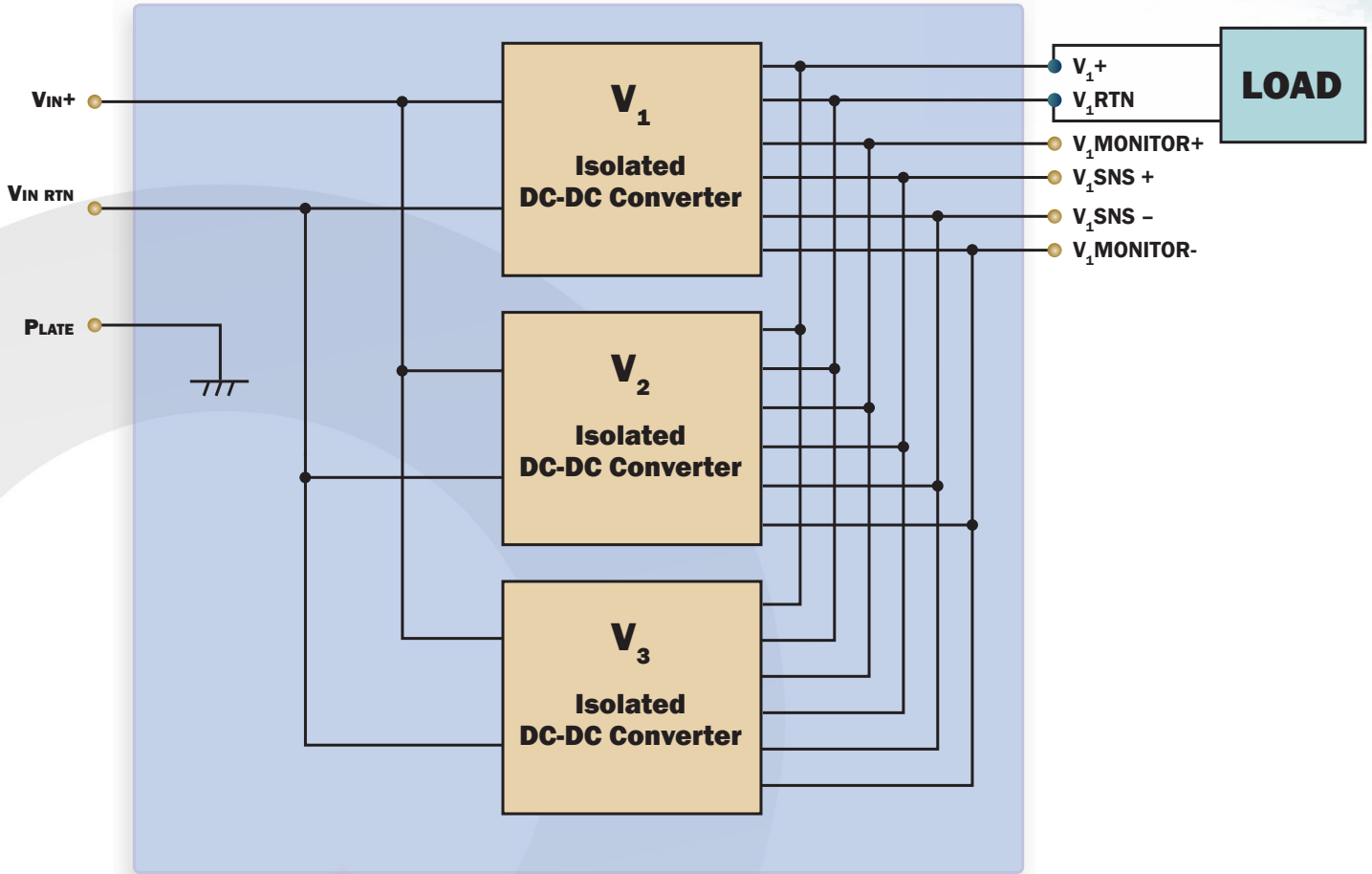



## MTQ-Px-DC28 Family Input Characteristics

Parameter	Min.	Typ.	Max.	Units	Notes & Conditions
<b>ABSOLUTE MAXIMUM RATINGS</b>					
<b>Input Voltage</b>					
Continuous	-1		60	V	Non-Operatiog
Transient ( $\leq 1$ s)			50	V	100ms transient, square
<b>Isolation Voltage</b>	-1500		1500	V	Input/Output to Plate
<b>Operating Temperature</b>	-55		100	°C	Plate Temperature
<b>Storage Temperature</b>	-65		135	°C	
<b>ELECTRICAL CHARACTERISTICS</b>					
<b>Input Voltage</b>					
Continuous	16		40	V	
Transient			50	V	50V transient for 100ms
<b>Under-Voltage Lockout</b>					
Turn-On Input Voltage Threshold	15.1	15.4	15.7	V	
<b>FEATURE CHARACTERISTICS</b>					
<b>System On/Off Control</b>					
System On-State Voltage	-0.5		0.7	V	Pin 9 (P1/P2) or Pin 10 (P3) of J5, referenced to AGND Pin can also be left open
System Off-State Voltage	2.5		8	V	
<b>Inhibit Control</b>					
Converter On-State Voltage	-0.5		0.7	V	Pin 2 (P1/P2) or Pin 5 (P3) of J5, referenced to AGND Pin can also be left open
Converter Off-State Voltage	2.5		8	V	

See individual DC-DC Converter and Filter Datasheets for more information regarding performance specifications, (MCOTS-C-28-xx-HZ).

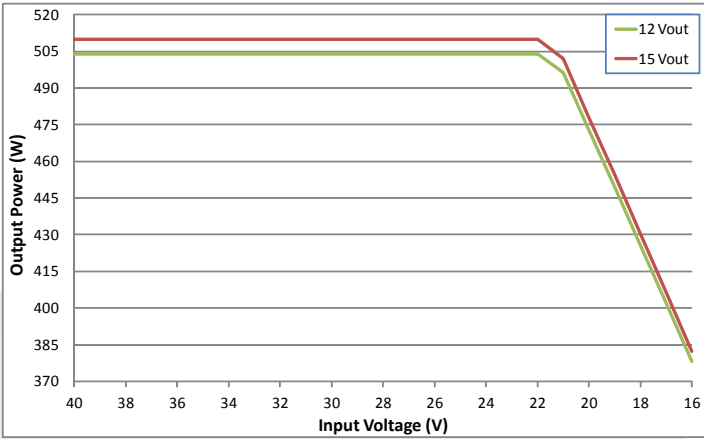

Figure 1. MTQ-P1 12V/15V Output Power Derating Across Entire Input/Thermal Operating Range

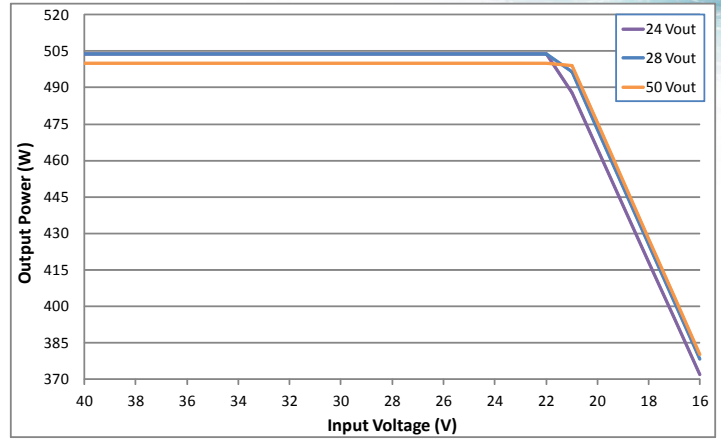

Figure 2. MTQ-P1 24V/28V/50V Output Power Derating Across Entire Input/Thermal Operating Range

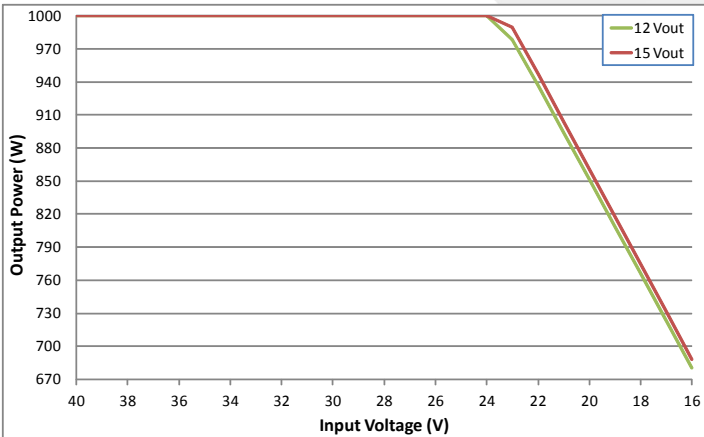

Figure 3. MTQ-P2 12V/15V Output Power Derating Across Entire Input/Thermal Operating Range

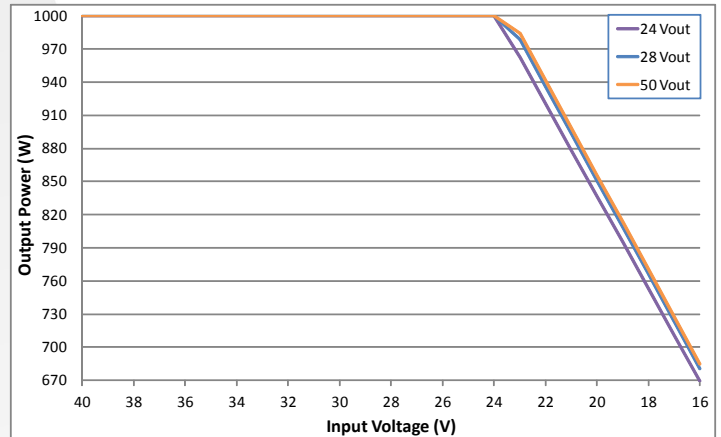

Figure 4. MTQ-P2 24V/28V/50V Output Power Derating Across Entire Input/Thermal Operating Range

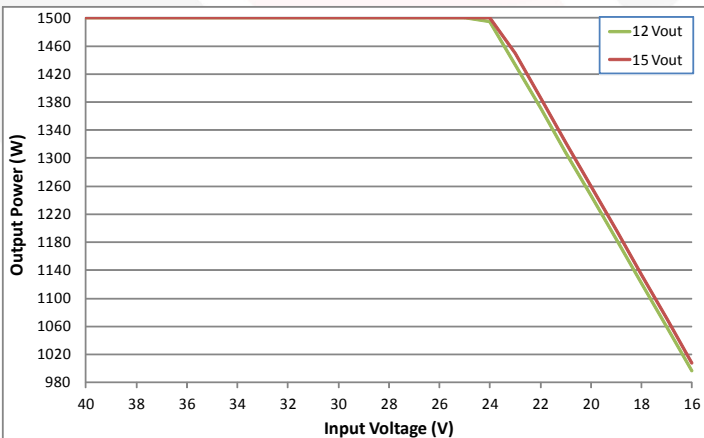

Figure 5. MTQ-P3 12V/15V Output Power Derating Across Entire Input/Thermal Operating Range

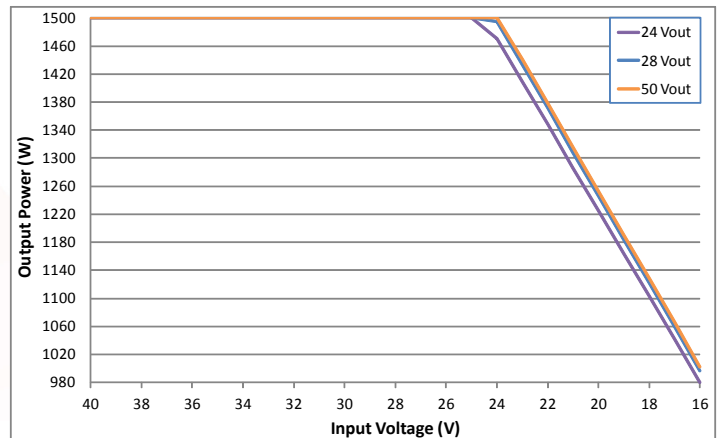
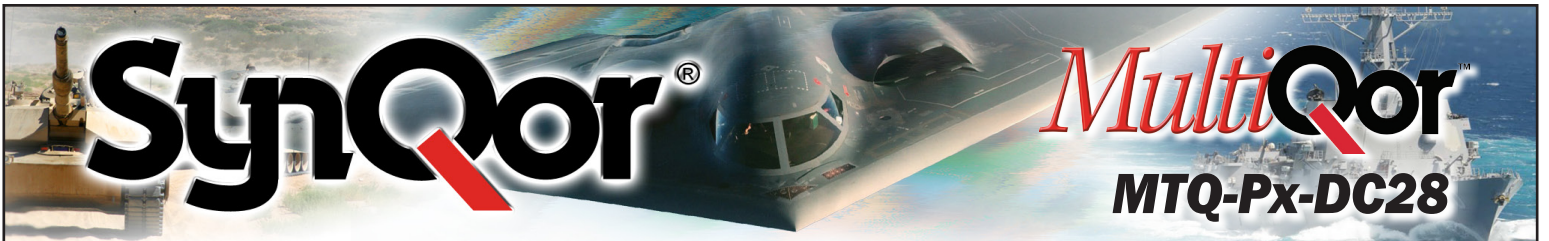

Figure 6. MTQ-P3 24V/28V/50V Output Power Derating Across Entire Input/Thermal Operating Range



**MTQ-Px-DC28**

## Mil-COTS DC-DC Converter Qualification

Test Name	Details	# Tested (# Failed)	Consistent with MIL-STD-883F Method	Consistent with MIL-STD-883F Method 5005
<b>Life Testing</b>	Visual, mechanical and electrical testing before, during and after 1000 hour burn-in @ full load	15 (0)	Method 1005.8	
<b>Shock-Vibration</b>	Visual, mechanical and electrical testing before, during and after shock and vibration tests	5 (0)		MIL-STD-202, Methods 201A & 213B
<b>Humidity</b>	+85 °C, 95%RH, 1000 hours, 2 minutes on/6 hours off	8 (0)	Method 1004.7	
<b>Temperature Cycling</b>	500 cycles of -55 °C to +100 °C (30 minute dwell at each temperature)	10 (0)	Method 1010.8	Condition A
<b>Solderability</b>	15 pins	15 (0)	Method 2003	
<b>DMT</b>	-65 °C to +110 °C across full line and load specifications in 5 °C steps	7 (0)		
<b>Altitude</b>	70,000 feet (21 km), see Note	2 (0)		

Note: A conductive cooling design is generally needed for high altitude applications because of naturally poor convective cooling at rare atmospheres.

## Mil-COTS DC-DC Converter Screening

Screening	Process Description	S-Grade	M-Grade
<b>Baseplate Operating Temperature</b>		-55 °C to +100 °C	-55 °C to +100 °C
<b>Storage Temperature</b>		-65 °C to +135 °C	-65 °C to +135 °C
<b>Pre-Cap Inspection</b>	IPC-610, Class III	Yes	Yes
<b>Temperature Cycling</b>	Method 1010, Condition B, 10 Cycles		Yes
<b>Burn-In</b>	100 °C Baseplate	12 Hours	96 Hours
<b>Final Electrical Test</b>	100%	25 °C	-55 °C, +25 °C, +100 °C
<b>Final Visual Inspection</b>	MIL-STD-2008	Yes	Yes

## MTQ-Px-DC28 Assembly Qualification

Environment Tests	Process Description	Details	Specification
<b>Vibration</b>	Method 514.6	Procedure I	20G's (0.2 g 2/Hz); 10-2000Hz
<b>Shock/Drop</b>	Method 516.6	Procedure I	40G's (11ms); 75G'speak (6ms); Sawtooth Pulse
<b>ESD</b>	EN 61000-4-2	Contact Discharge	Level 2

### MECHANICAL DRAWING P1

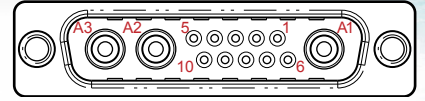
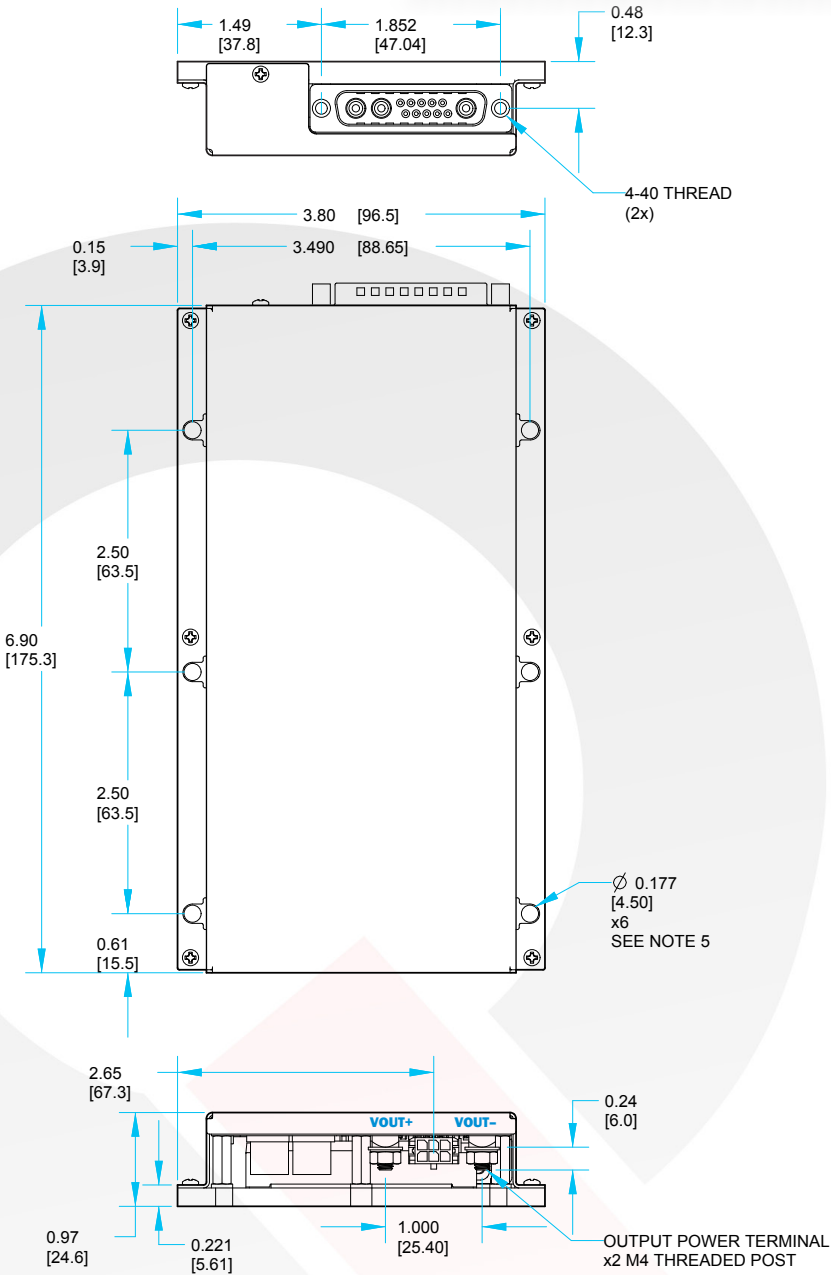

**Input Connector (J5) 13W3**

Pin	Name	Function
1	AGND	Analog Ground <sup>1</sup>
2	INH	Inhibit [Ref to AGND]
3	NC	Not Connected
4	NC	Not Connected
5	NC	Not Connected
6	INPUT_GOOD	[Ref to AGND]
7	NC	Not Connected
8	NC	Not Connected
9	ON/OFF	[Ref to AGND]
10	VIN-	[Signal Connection] <sup>2</sup>
A1	COM IN	Chassis
A2	VIN-	[Power connection]
A3	VIN+	[Power connection]

**NOTES:**

- AGND, Pin 1, is the reference for control inputs INH, ON/OFF, and control output INPUT\_GOOD. It should be connected to the reference of the external drivers and receivers of these signals. It is isolated from VIN- and VIN+.
- Vin-, Pin 10, should not be connected externally to Vin-, Pin A2. It can be connected to AGND, Pin 1, externally if the user wishes the control signal reference to be local to the MTQ assembly.

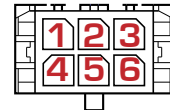

**Output Connector (J1)**

Pin	Name	Function
1	MONITOR+	Output Monitor Positive
2	NC	Not Connected
3	MONITOR-	Output Monitor Negative
4	VSENSE+	Sense Positive
5	TRIM	Trim Pin
6	VSENSE-	Sense Negative

**NOTES:**

- All dimensions in inches [MM]
- Tolerances: X.XX ±0.02 IN [±0.5MM]  
X.XXX ±0.010 IN [±0.25MM]
- Connector Part Numbers:  
J5 COMBO-D 13W3 MALE  
J1 MOLEX 430450606
- Weight: Total assembly weight depends on actual converter used.  
Typical Weight: 1.16 LBS (1 HB)
- Torque Spec for Mounting Holes and Output Terminals, 6in—lbs. Torque Spec for Input Accessory Cable Jack-Screws, 4in—lbs.

### MECHANICAL DRAWING P2 - 2 OUTPUT TERMINAL

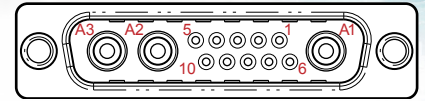
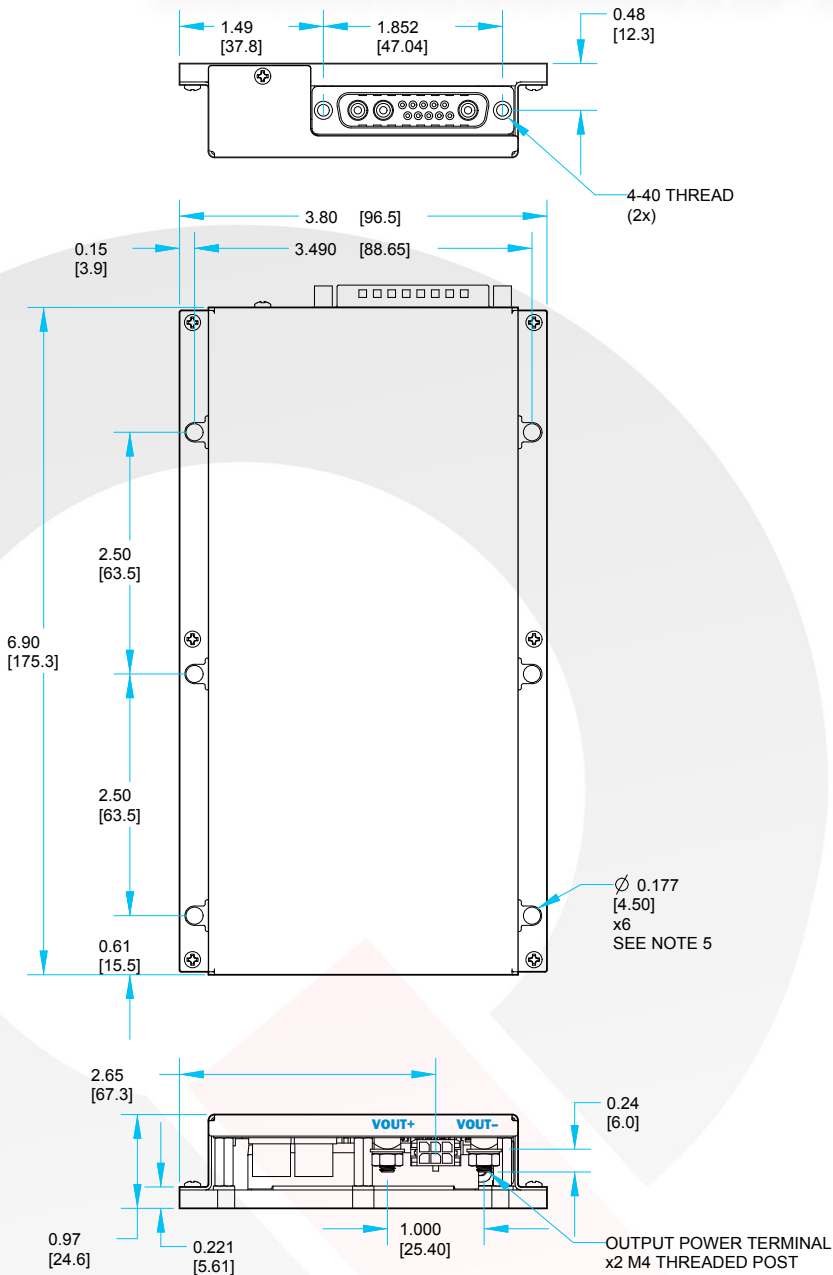

**Input Connector (J5) 13W3**

Pin	Name	Function
1	AGND	Analog Ground <sup>1</sup>
2	INH	Inhibit [Ref to AGND]
3	NC	Not Connected
4	NC	Not Connected
5	NC	Not Connected
6	INPUT_GOOD	[Ref to AGND]
7	NC	Not Connected
8	NC	Not Connected
9	ON/OFF	[Ref to AGND]
10	VIN-	[Signal Connection] <sup>2</sup>
A1	COM IN	Chassis
A2	VIN-	[Power connection]
A3	VIN+	[Power connection]

**NOTES:**

- AGND, Pin 1, is the reference for control inputs INH, ON/OFF, and control output INPUT\_GOOD. It should be connected to the reference of the external drivers and receivers of these signals. It is isolated from VIN- and VIN+.
- Vin-, Pin 10, should not be connected externally to Vin-, Pin A2. It can be connected to AGND, Pin 1, externally if the user wishes the control signal reference to be local to the MTQ assembly.

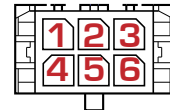

**Output Connector (J1)**

Pin	Name	Function
1	MONITOR+	Output Monitor Positive
2	NC	Not Connected
3	MONITOR-	Output Monitor Negative
4	VSENSE+	Sense Positive
5	NC	Not Connected
6	VSENSE-	Sense Negative

**NOTES:**

- All dimensions in inches [MM]
- Tolerances: X.XX ±0.02 IN [±0.5MM]  
X.XXX ±0.010 IN [±0.25MM]
- Connector Part Numbers:  
J5 COMBO-D 13W3 MALE  
J1 MOLEX 430450606
- Weight: Total assembly weight depends on actual converter used.  
Typical Weight: 1.49 LBS (2 HB)
- Torque Spec for Mounting Holes and Output Terminals, 6in—lbs. Torque Spec for Input Accessory Cable Jack-Screws, 4in—lbs.
- 2 Output Terminals used for Total Iout ≤ 60A

### MECHANICAL DRAWING P2 - 4 OUTPUT TERMINAL

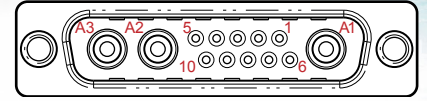
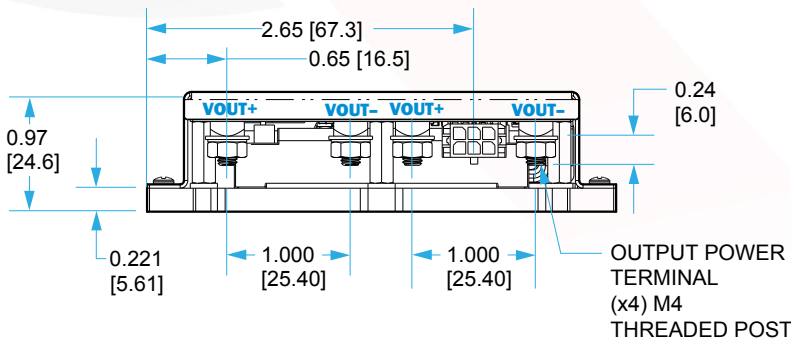
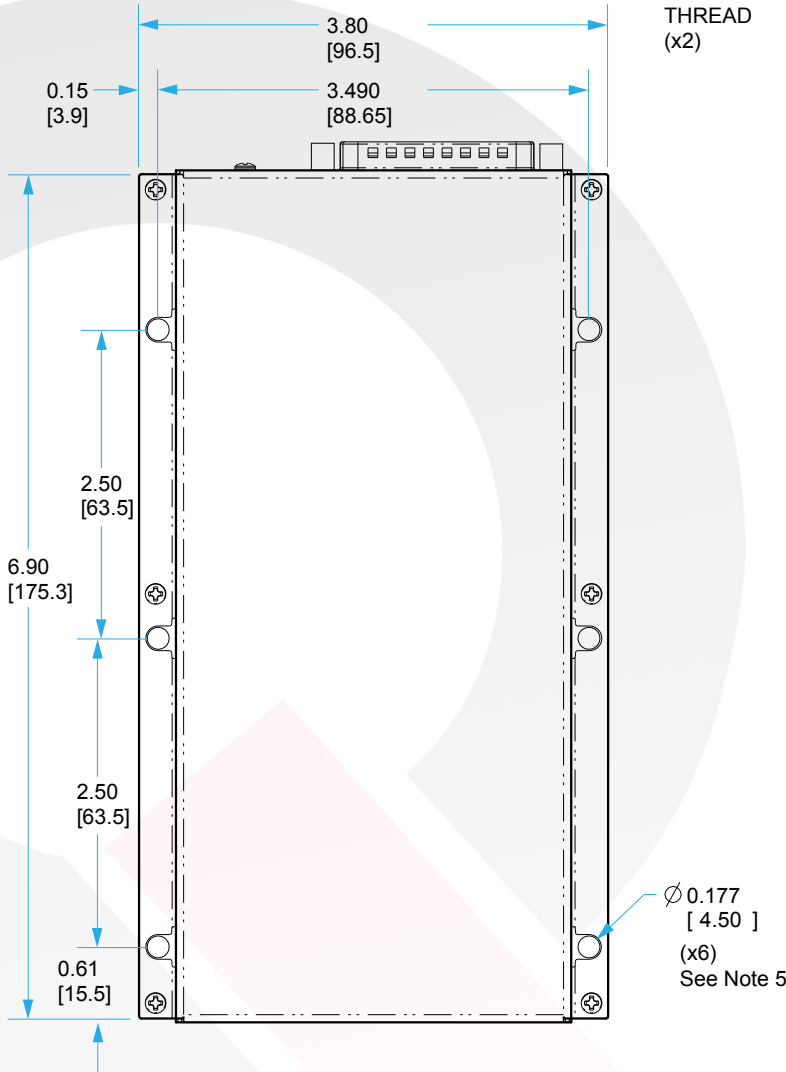
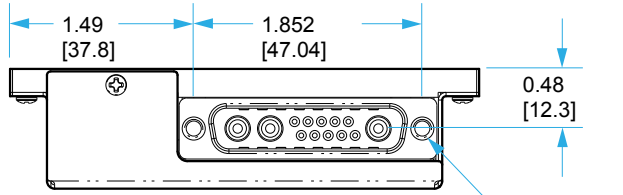

**Input Connector (J5) 13W3**

Pin	Name	Function
1	AGND	Analog Ground <sup>1</sup>
2	INH	Inhibit [Ref to AGND]
3	NC	Not Connected
4	NC	Not Connected
5	NC	Not Connected
6	INPUT_GOOD	[Ref to AGND]
7	NC	Not Connected
8	NC	Not Connected
9	ON/OFF	[Ref to AGND]
10	VIN-	[Signal Connection] <sup>2</sup>
A1	COM IN	Chassis
A2	VIN-	[Power connection]
A3	VIN+	[Power connection]

**NOTES:**

- AGND, Pin 1, is the reference for control inputs INH, ON/OFF, and control output INPUT\_GOOD. It should be connected to the reference of the external drivers and receivers of these signals. It is isolated from VIN- and VIN+.
- Vin-, Pin 10, should not be connected externally to Vin-, Pin A2. It can be connected to AGND, Pin 1, externally if the user wishes the control signal reference to be local to the MTQ assembly.

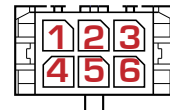

**Output Connector (J1)**

Pin	Name	Function
1	MONITOR+	Output Monitor Positive
2	NC	Not Connected
3	MONITOR-	Output Monitor Negative
4	VSENSE+	Sense Positive
5	NC	Not Connected
6	VSENSE-	Sense Negative

**NOTES:**

- All dimensions in inches [MM]
- Tolerances: X.XX ±0.02 IN [±0.5MM]  
X.XXX ±0.010 IN [±0.25MM]
- Connector Part Numbers:  
J5 COMBO-D 13W3 MALE  
J1 MOLEX 430450606
- Weight: Total assembly weight depends on actual converter used.  
Typical Weight: 1.49 LBS (2 HB)
- Torque Spec for Mounting Holes and Output Terminals, 6in—lbs. Torque Spec for Input Accessory Cable Jack-Screws, 4in—lbs.
- 4 Output Terminals needed for Total Iout > 60A

### MECHANICAL DRAWING P3

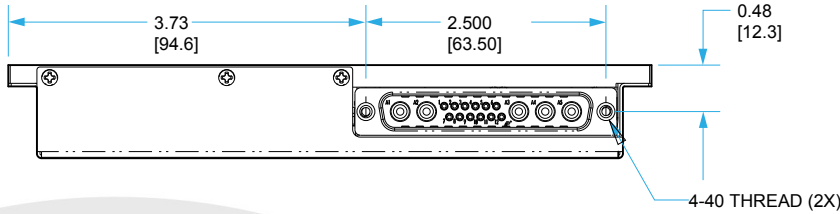

#### Input Connector (J5) 17W5

Pin	Name	Function
1	INPUT_GOOD	[Ref to AGND]
2	NC	Not Connected
3	NC	Not Connected
4	NC	Not Connected
5	INH	Inhibit [Ref to AGND]
6	AGND	Analog Ground <sup>1</sup>
7	NC	Not Connected
8	NC	Not Connected
9	VIN-	[Signal Connection] <sup>2</sup>
10	ON/OFF	[Ref to AGND]
11	NC	Not Connected
12	NC	Not Connected
A1	VIN+	[Power connection]
A2	VIN+	[Power connection]
A3	VIN-	[Power connection]
A4	VIN-	[Power connection]
A5	COM IN	Chassis

#### NOTES:

- AGND, Pin 6, is the reference for control inputs INH, ON/OFF, and control output INPUT\_GOOD. It should be connected to the reference of the external drivers and receivers of these signals. It is isolated from VIN- and VIN+.
- Vin-, Pin 9, should not be connected externally to Vin-, Pins A3 and A4. It can be connected to AGND, Pin 6, externally if the user wishes the control signal reference to be local to the

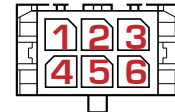
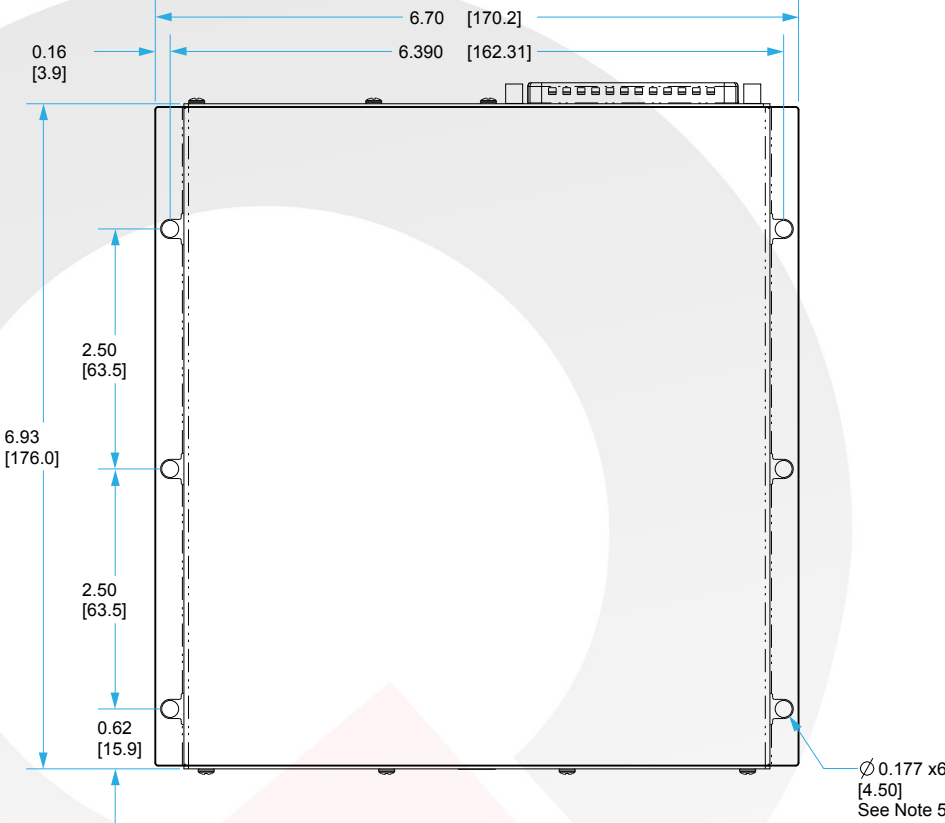

#### Output Connector (J1)

Pin	Name	Function
1	MONITOR+	Output Monitor Positive
2	NC	Not Connected
3	MONITOR-	Output Monitor Negative
4	VSENSE+	Sense Positive
5	NC	Not Connected
6	VSENSE-	Sense Negative

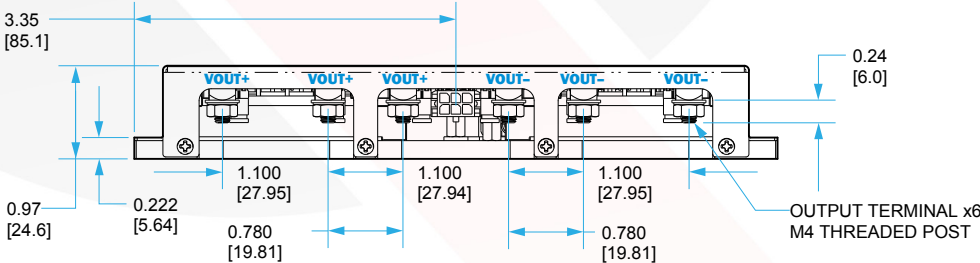

#### NOTES:

- All dimensions in inches [MM]
- Tolerances: X.XX ±0.02 IN [±0.5MM]  
X.XXX ±0.010 IN [±0.25MM]
- Connector Part Numbers:  
J5 COMBO-D 17W5 MALE  
J1 MOLEX 430450606
- Weight: Total assembly weight depends on actual converter used.  
Typical Weight: 2.49 LBS (3 HB)
- Torque Spec for Mounting Holes and Output Terminals, 6in—lbs. Torque Spec for Input Accessory Cable Jack-Screws, 4in—lbs.

## MultiQor Control Circuitry Features

The MTQ-Px-DC28 has control feature signals available on the connector, J5.

### Converter SYSTEM ON/OFF:

The MTQ-Px-DC28T has two options for the user to control when a converter is on or off. There is a SYSTEM ON/OFF control, shown in Figure A. The SYSTEM ON/OFF pin, Pin 9 (P1/P2) or Pin 10 (P3) of J5, must be pulled high to turn all the converters off. The SYSTEM ON/OFF controls are referenced to AGND, Pin 1 (P1/P2) or Pin 6 (P3) of J5.

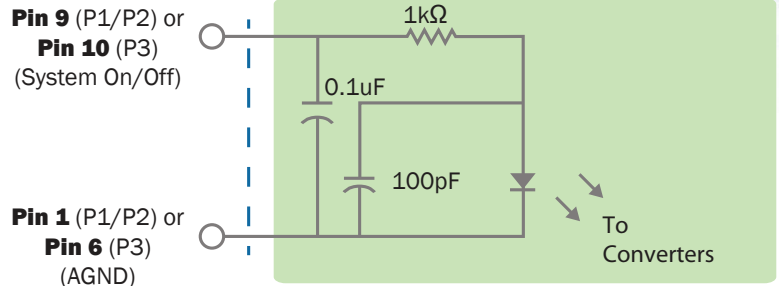

Figure A: An equivalent circuit looking into the SYSTEM ON/OFF pin.

### INHIBIT Controls:

MTQ-Px-DC28 has an INHIBIT control, shown in Figure B. The specific INHIBIT pin, Pin 2 (P1/P2) or Pin 5 (P3) of J5, must be pulled high to keep the converter(s) off even when the SYSTEM ON/OFF pin is low. The INHIBIT controls are referenced to AGND, Pin 1 (P1/P2) or Pin 6 (P3) of J5.

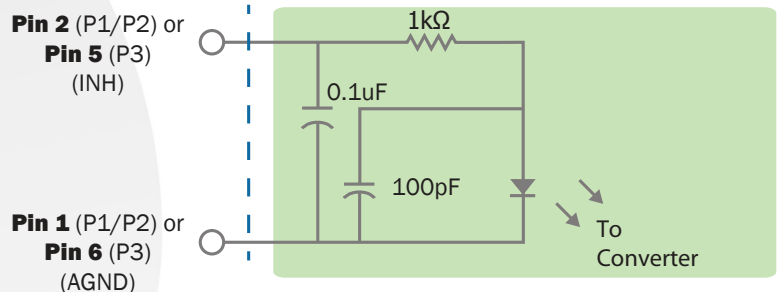

Figure B: An equivalent circuit looking into the INHIBIT pin.

### Control Summary

System On/Off	Inhibit	Output(s)
Low	Low	On
High	High	Off
High	x	Off
x	High	Off

### INPUT GOOD:

The INPUT GOOD signal, Pin 6 (P1/P2) or Pin 1 (P3) of J5, is an open collector output which is pulled low when the converters have an input voltage above 16V. This signal is referenced to AGND, Pin 1 (P1/P2) or Pin 6 (P3) of J5. An example external 5V pull-up circuit is shown in Figure C.

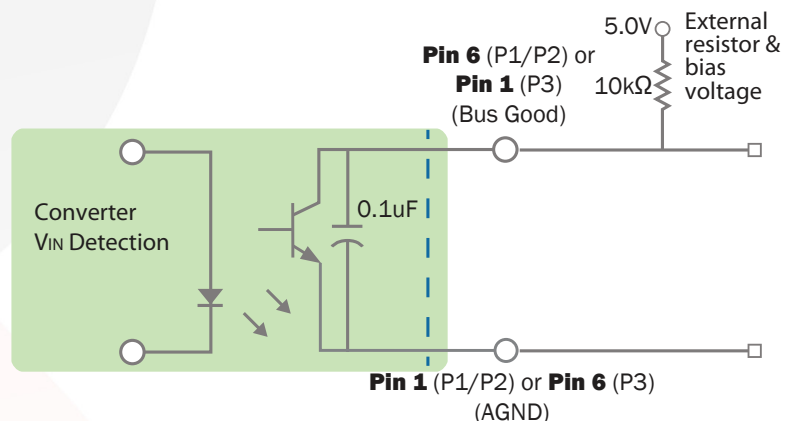
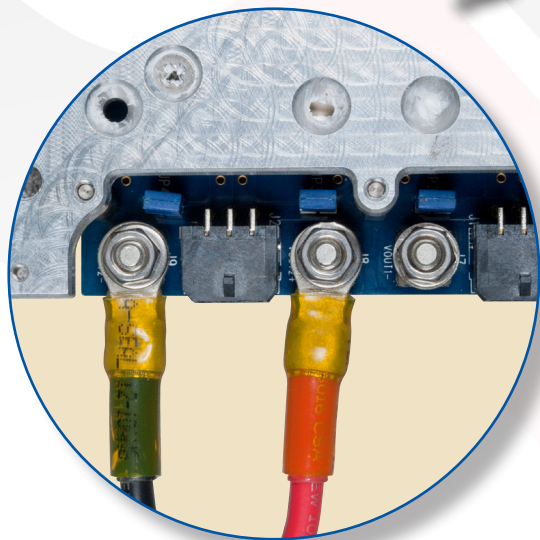
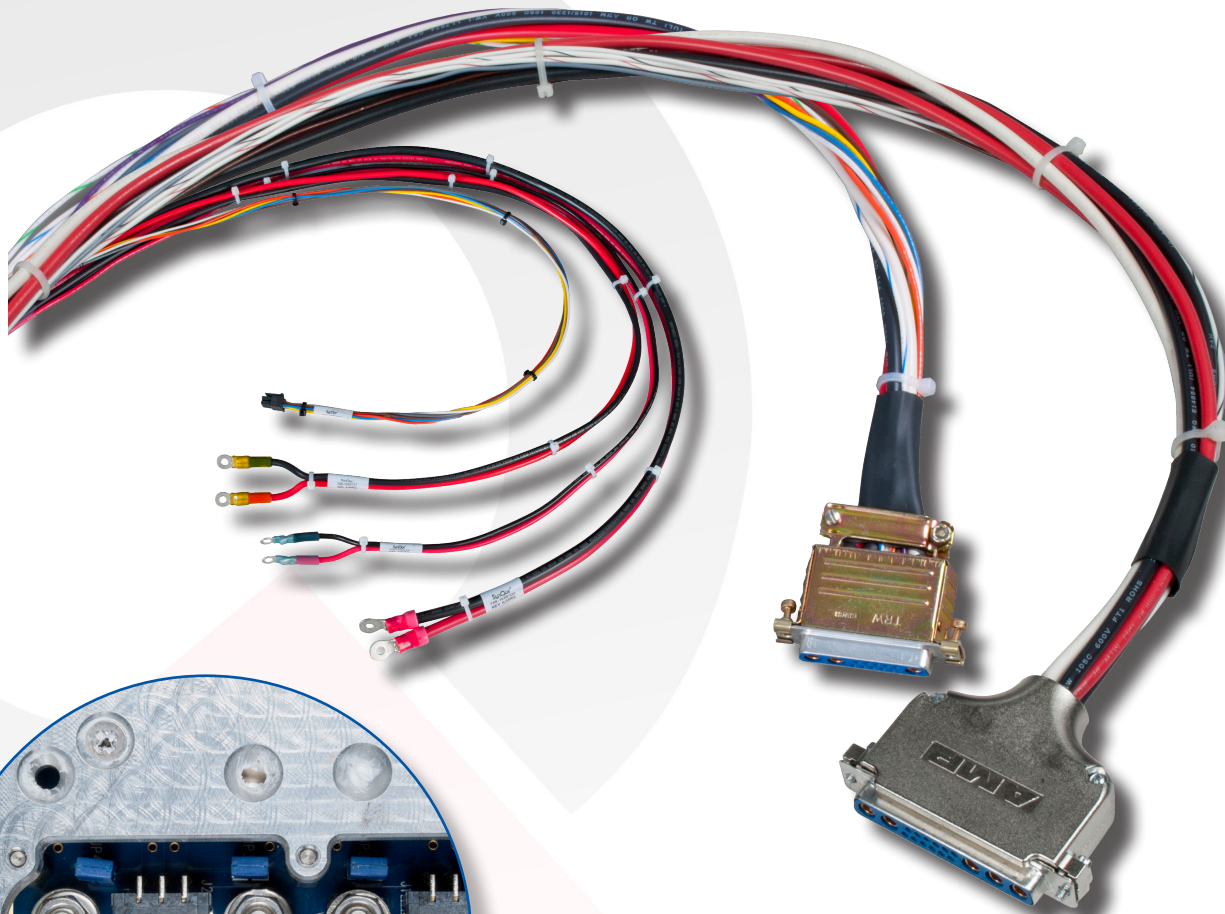

Figure C: An equivalent circuit looking into the INPUT GOOD pin with an example external pull-up circuit.

### MultiQor Plate Cables

These cables can be used with MultiQor Plates and Adaptor Boards with multiple output options to accommodate different levels of output current.

Description	Part Number
Input mating cable with pre-stripped wire ends (36") P1	MTQ-CBL-INPUT1C
Input mating cable with pre-stripped wire ends (36") P2	MTQ-CBL-INPUT3C
Input mating cable with pre-stripped wire ends (36") P3	MTQ-CBL-INPUT2C
Output signal mating cable with pre-stripped wire ends (36")	MTQ-CBL-OUT1CS
Output power mating cable (20A) with pre-stripped wire ends (36")	MTQ-CBL-OUT1CP20
Output power mating cable (40A) with pre-stripped wire ends (36")	MTQ-CBL-OUT1CP40
Output power mating cable (60A) with pre-stripped wire ends (36")	MTQ-CBL-OUT1CP60



### POWER CONNECTION

NOTE: J1 - J4 Monitor Pins are not rated to carry the converter's output. Output terminal studs should be used as shown.



## Ordering Information / Part Numbering

**MTQ - P1 - DC28 - XXXXXXXX - S V**

Family	Plate Format (# of Converters)	MIL-STD Compliance	8 Digit Application Identification Number	Screening	Optional Character
<b>MTQ</b>	<b>P1:</b> 1 converter <b>P2:</b> 2 converters <b>P3:</b> 3 converters	<b>DC28:</b> MIL-STD-704 (A-F) (Steady State)	8 Digit Application Identification Number	<b>S:</b> S-Grade <b>M:</b> M-Grade	<b>V:</b> Cover

Not all combinations make valid part numbers, please contact SynQor to order a configured solution.

**Example: MTQ-P3-DC28-XXXXXXXX-SV**



**Contact SynQor for further information and to order:**

**Phone:** 978-849-0600    **Fax:** 978-849-0602  
**E-mail:** [power@synqor.com](mailto:power@synqor.com)    **Web:** [www.synqor.com](http://www.synqor.com)  
**Address:** 155 Swanson Road, Boxborough, MA 01719 USA

**WARRANTY**

SynQor offers a two (2) year limited warranty. Complete warranty information is listed on our website or is available upon request from SynQor.

**PATENTS**

SynQor holds numerous U.S. patents, one or more of which apply to most of its power conversion products. Any that apply to the product(s) listed in this document are identified by markings on the product(s) or on internal components of the product(s) in accordance with U.S. patent laws. SynQor's patents include the following:

7,765,687	7,787,261
8,149,597	8,644,027