



<b>1500 VA/ 1250 W Output Power</b>	<b>80-265 Vrms 47-65 Hz or 47-800 Hz AC Input Voltage Options</b>	<b>115 Vrms or 230 Vrms 50 Hz, 60 Hz or 400 Hz AC Output Voltage Options</b>	<b>28 Vnom DC Input Voltage Option</b>	<b>500 W or 1250 W DC Output Voltage Option</b>
---	---	--	--	---

*Sealed Construction, Ultra low Weight, Compact Size*



**N+M REDUNDANCY**  
*(optional)*

DESIGNED & MANUFACTURED IN USA

SynQor’s Military Field-Grade Power Conditioner units are designed for the extreme environmental and demanding electrical conditions of Military/Aerospace applications. SynQor’s MPC incorporates field proven high efficiency designs and rugged packaging technologies. This MPC will accept a wide range of input voltage and frequency values while delivering a well-conditioned AC output to the load. It is designed and manufactured in SynQor’s USA facilities to comply with a wide range of military standards. Options include two DC outputs, a DC input rated for military 28 VDC sources, and an electronic breaker on the AC output to permit fault-tolerant parallel operation for higher power and/or N+M redundant systems.

**Combine units for Higher Power, Voltage, 3-Phase AC output, and/or Redundancy**

**Features**

- Sealed, weather-proof, shock-proof construction
- 1250 W (1500 VA) output power
- Full power operation: -40 °C to +55 °C
- Universal AC input: 80-265 VAC; 47-65 Hz
- Power factor correction at AC input
- Dual input (AC and optional DC)
- True on-line double conversion
- Pure sinusoidal AC output voltage (115 VAC, 60 Hz)
- Handles 0.0—1.0 power factor loads and non-linear loads
- Up to 3 units can be combined for higher power, voltage or a 3-Phase AC output
- Up to 32 units can be combined to form a higher power fault-tolerant, glitch-free system, perhaps with N+M redundancy, by ordering with the "AC Output Electronic Breaker" option and the appropriate configuration cable
- User I/O and Configuration signal ports
- 1U high rack mount unit (17.00"W x 14.80"D x 1.73"H)
- Low weight: 22 lbs.

**In-Line Manufacturing Process**

- AS9100 and ISO 9001 certified facility
- Full component traceability

**Options**

- DC input (28 Vnom) for dual source
- Wide-range AC input frequency: 47 Hz to 800 Hz
- 115 Vrms or 230 Vrms AC output
- 50 Hz, 60 Hz, or 400 Hz output
- DC1: Auxiliary isolated DC output (up to 500 W)
- DC2: High power DC output (up to 1250 W) parallelable for higher power
- Shipboard version with floating neutral wire
- N+M redundancy

**Specification Compliance**

MPC-1500 units are designed to meet:

- MIL-STD-1399-300B - Interface Std for Shipboard Systems
- MIL-STD-810G - Environmental Engineering Considerations
- MIL-STD-461F - Electromagnetic Interference
- MIL-STD-704F - Aircraft Electrical Power Characteristics
- MIL-STD-1275D - Vehicle Electrical Power Characteristics

**Contents**

Technical Specification.....2  
 Block Diagram.....4  
 Application Section.....5  
 Mechanical Diagrams.....8  
 Accessory Options.....9  
 Ordering Information.....10

### Technical Specification

#### INPUT CHARACTERISTICS

##### Operating AC Input

Voltage	80-265 Vrms*
Frequency	47-65 Hz (47-800 Hz Optional)
Input Power Factor	>0.98 at 47-65 Hz >0.97 at 400 Hz >0.93 at 800 Hz

Maximum Input Current Continuous	20 A (full load, 85 Vrms)
AC Input Circuit Breaker Rating (* Power Derating to 80% below 90 Vrms)	25 A

##### Operating DC Input (Optional)

Voltage	22-33 V
Continuous Maximum Input Current	62 A (full load, 22 V)
Transient Maximum Input Current	75 A

#### OUTPUT CHARACTERISTICS

Total Output Power Continuous	1250 W (1500 VA)
Maximum DC1 Output Power	510 W
Maximum DC2 Output Power	1250 W

(Note: Available AC power is reduced by power delivered to the DC output)

##### AC Output

AC Output Waveform	Pure Sinusoidal	
Voltage	115 Vrms ± 3%	230 Vrms ± 3%
Frequency	60 Hz ± 0.5%	50 Hz ± 0.5%
	400 Hz ± 0.5%	
Peak Load Current	26 A (115 Vrms)	13 A (230 Vrms)
Load Power Factor	0-1.0 (leading or lagging)	
Total Harmonic Distortion	2% (1000W resistive load)	

##### DC1 Output (optional)

Voltage Regulation (Over Load & Temperature) ± 3%		
Common Voltage/Power combinations (DC1) (Other Options Available)	12 V at 42 A	=504 W
	15 V at 34 A	=510 W
	24 V at 21 A	=504 W
	28 V at 18 A	=504 W
	40 V at 12.5 A	=500 W
	50 V at 10 A	=500 W

##### DC2 Output (optional)

Voltage Setpoint	± 3%	
Voltage Regulation (Over Load & Temperature) -2%		
Common Voltage/Power combinations (DC2)	50 V at 20 A	=1000 W
	24 V at 50 A	=1200 W
	28 V at 44.6 A	=1250 W

##### Droop Share (Output droops vs. load to allow passive sharing among modules.)

##### 24 V Option

Voltage Regulation (Over Load & Temperature) -15%		
	26 V at 0 A	
	22 V at 50 A	=1100 W

##### 28 V Option

Voltage Regulation (Over Load & Temperature) -13%		
	30 V at 0 A	
	26 V at 48.1 A	=1250 W

##### 50 V Option

Voltage Regulation (Over Load & Temperature) -10%		
	52 V at 0 A	
	48.5 V at 20.6 A	=1000 W

#### ENVIRONMENTAL CHARACTERISTICS MIL-STD-810G

##### Temperature Methods 501.5, 502.5

Operating Temperature	-40 °C to +70 °C <sup>1</sup>
Non-operating Temperature	-40 °C to +70 °C

##### Altitude Method 500.5

Operating	0 - 18,000 ft
Non-operating	0 - 40,000 ft

##### Environmental Tests

Shock/Drop	Method 516.6, Procedures 1,4,6
Temperature Shock	Method 503.5, Procedure 1
Vibration	Method 514.6, CAT 5, 7, 8, 9, 24
Fungus	Method 508.6
Salt Fog	Method 509.5
Sand and Dust	Method 510.5, Procedures 1,2
Rain	Method 506.5 Procedure 1
Humidity	Method 507.5 Procedure 2
Mechanical Vibrations of Shipboard Equipment	Method 528 Procedure 1

#### RELIABILITY CHARACTERISTICS MIL-HDBK-217F

MTBF	100 kHrs	MIL-217F Ground Benign, Ta=25 °C
------	----------	----------------------------------

#### ELECTROMAGNETIC CAPABILITY MIL-STD-461F

CE101	30 Hz - 10 kHz
CE102	10 kHz - 10 MHz
CS101	30 Hz - 150 kHz
CS106	10 kHz - 40 GHz
CS114	10 kHz - 200 MHz
CS116	10 kHz - 100 MHz
RE101	30 Hz - 100 kHz
RE102	10 kHz - 18 GHz
RS101	30 Hz - 100 kHz
RS103	2 MHz - 40 GHz

#### MECHANICAL CHARACTERISTICS

##### 1U Standard Chassis

Chassis Size	17.00"W x 14.80"D x 1.73"(1U)H
Case Material	Aluminum
Total Weight	22 lbs.

##### Connectors

AC Input Connector	MS3470L14-4P
User I/O Ports	HD DB15 Female
Configuration I/O Port	HD DB15 Male
Ethernet Port	Amphenol RJF22N00, Code B
DC Input Connector	MS3470L18-8P
AC Output Connector	MS3470L14-4S
DC1 Output Connector	MS3470L14-4SW
DC2 Output Connector	MS3470L18-8S

##### Cooling Exhaust Fans

Sound Pressure Level (SPL)	54 dB(A)
Air Flow	0.67(m³/min) 23.7 CFM

Two fans in system, above specs are for each fan separately.

<sup>1</sup> 100% rated power at 55C, 0% rated power at 70C. Derate linearly.



**MPC** MILITARY  
FIELD-GRADE  
**MPC-1500-1S**

**Safety & Qualifications**

**High Density DB15 Female (15 Pin Connector)**

Signal	PIN Number	Function
TX	2	RS232 DCE Device Transmit
RX	3	RS232 DCE Device Receive
GND	4, 5	Ground reference for all digital inputs and outputs
ACIN_GOOD	7	Open collector output where "low" indicates AC Input voltage is within range
+5V	8	Vout with minimal current drive usable as a pull-up voltage for open collector output signals. Load must be <35 mA
REMOTE_START	12	Drive this line "high" with $\geq 5$ mA to enable MPC outputs
SHUTDOWN	13	Drive this line "high" with $\geq 5$ mA to disable MPC outputs
OUT_OK	14	Open collector output where "low" indicates AC Output voltage is within range
OVER_TEMP	15	Open collector output where "low" indicates that the MPC is at or above its maximum temperature



**Safety & Qualifications - Pending**

- UL 62368-1
- CAN/CSA C22.2 No.62368-1
- EN 62368-1
- IEC-62368



# SynQor®

**MPC** MILITARY FIELD-GRADE

**MPC-1500-1S**

## Block Diagram

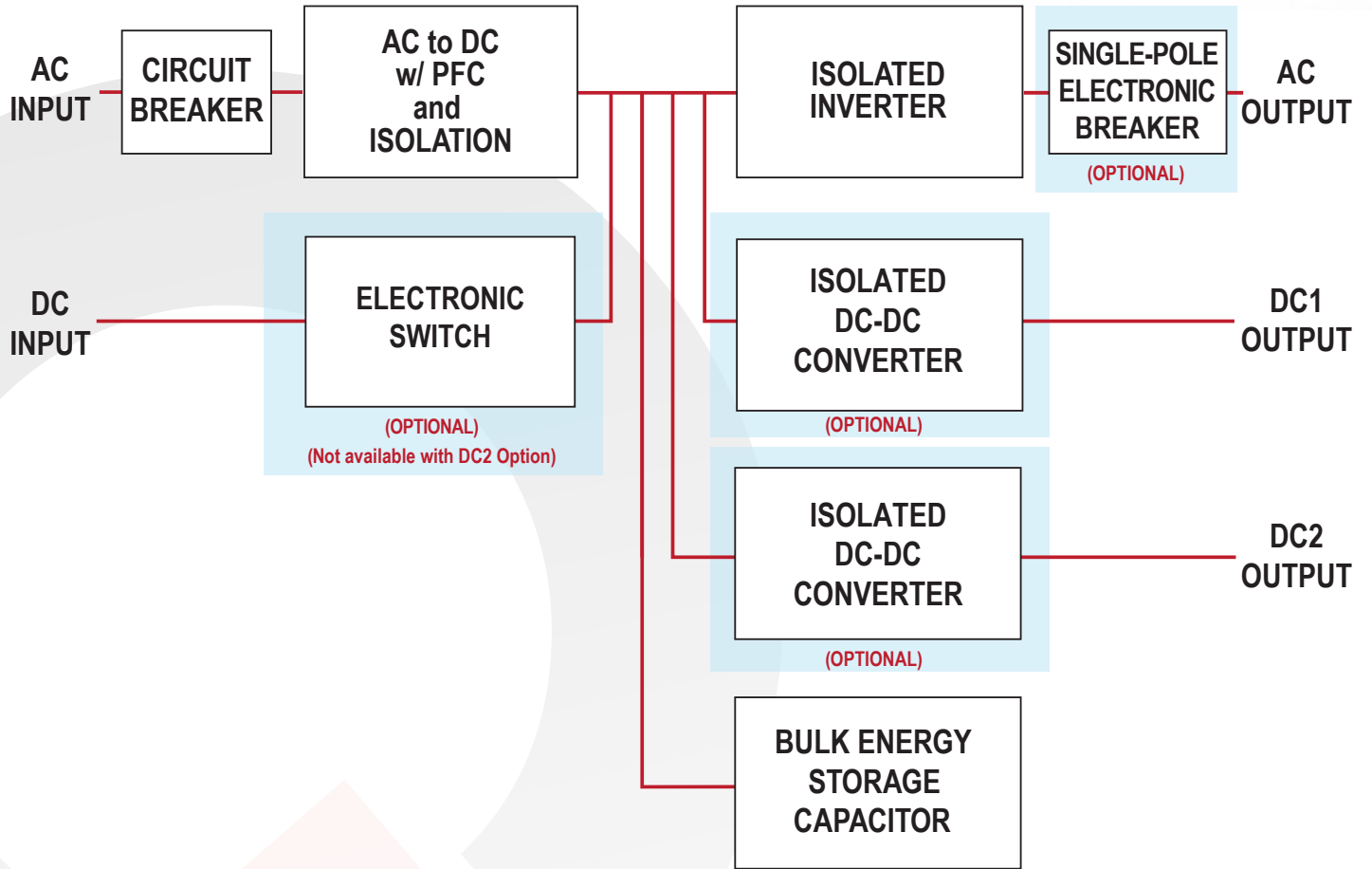

### “R” Option: AC Output Electronic Breaker

#### Fault Tolerant, Glitch-Free Operation

The “R” option adds an electronic breaker to the AC output of the MPC to permit fault-tolerant, glitch-free parallel operation. With this option, when several MPC units are connected in parallel at their AC outputs and one unit has an internal fault that might otherwise have pulled down the AC output bus, the electronic breaker will disconnect the failed unit so that the remaining paralleled units can continue to power the bus. This allows the system to be “fault-tolerant”. The disconnect occurs very quickly so that the AC output voltage will remain within its specified parameters as long as the remaining paralleled units can deliver the total load power. This allows the system to continue running “glitch-free”.

The electronic breaker is a single-pole breaker present in the hot-side AC output wire only. The neutral AC output wire is left floating from the MPC chassis to facilitate the paralleling of units into various configurations.

#### Expanded Paralleling

The “R” option also increases the total number of MPC units that can be paralleled to a maximum of 32. AC output current sharing among the paralleled units is accomplished with a high speed digital configuration cable. The units will share the total load current to within  $\pm 2\%$ , and for a split-phase or 3-phase system the AC voltages and AC currents will have phase balance within  $\pm 2$  degrees.

#### N+M Redundancy

Besides permitting a higher number of MPC units to be paralleled, the “R” option also makes it possible to set up N+1, or more generally N+M, redundant systems with a total of up to 32 MPC units. In such a system the failure of one unit (or M units) will not cause the overall system to fail. A failed unit can then be replaced to return the redundancy level to its original design. The replacement unit can be inserted into a live, operating system with proper precautions, but for safety reasons it is recommended that the system be turned off first.

#### Output Power Cable Connection

MPC systems are formed by first connecting the neutral wires of all the individual units together. For single phase systems, the hot wires are also connected together to form a single bank of MPC units. Split-phase systems are formed by connecting the hot output wires into two banks. One bank will have its output voltage phase-shifted  $180^\circ$  from the other. The phase-shift is determined by the configuration cable. Similarly, 3-phase systems are formed by grouping the hot output wires into three banks, each bank having its output voltage phase-shifted by  $120^\circ$ . Again, the phase shift is determined by the configuration cable. Since 3-phase systems are formed by connecting the neutral wires together and phase shifting the hot wires, the AC outputs must be wye-connected to form 3-phase systems. Delta connection of MPC units is not supported. However, once a 3-phase system is formed, loads may be connected as wye or delta.

The diagrams on the following page give examples of how multiple MPC units with the “R” option can be connected to create higher output power single-phase, split-phase, and 3-phase AC systems that will have N+M redundancy as long as N units are sufficient for the maximum load power per phase. Note, again, that the maximum total number of units that can be arranged in any of these configurations is 32.

#### Configuration Cables

Any system of “R” option MPC units requires a specific configuration cable that defines the arrangement of MPC units in the system. The configuration cable determines the phase shift for split-phase and 3-phase systems. The cable also provides high speed digital communication for current sharing on each phase.

Configuration cables for two parallel units and three parallel units in a single-phase system are available as standard products. Please contact the factory to purchase configuration cables for systems larger than three MPC units, or systems that have split-phase or 3-phase AC outputs.

Configuration cables are required for paralleling the AC output only. The DC2 output relies on droop share for paralleling, and does not require a configuration cable. See the “Ordering Information” page for DC2 output options with droop share that can be paralleled.

## Application Section

### Single Phase Output System

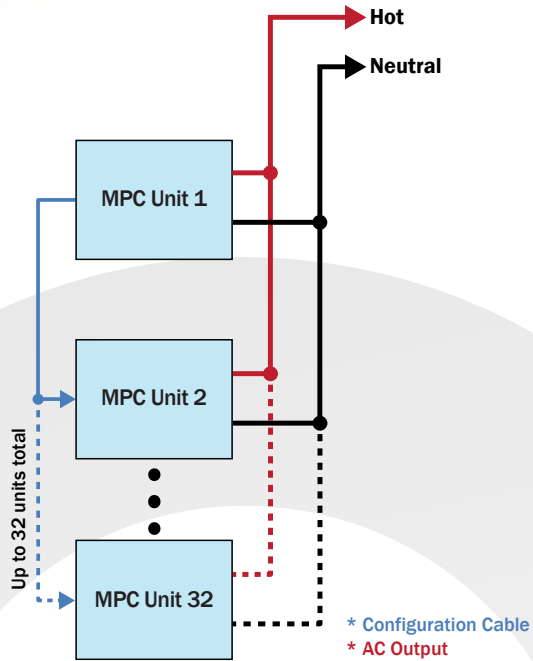

### Split Phase Output System

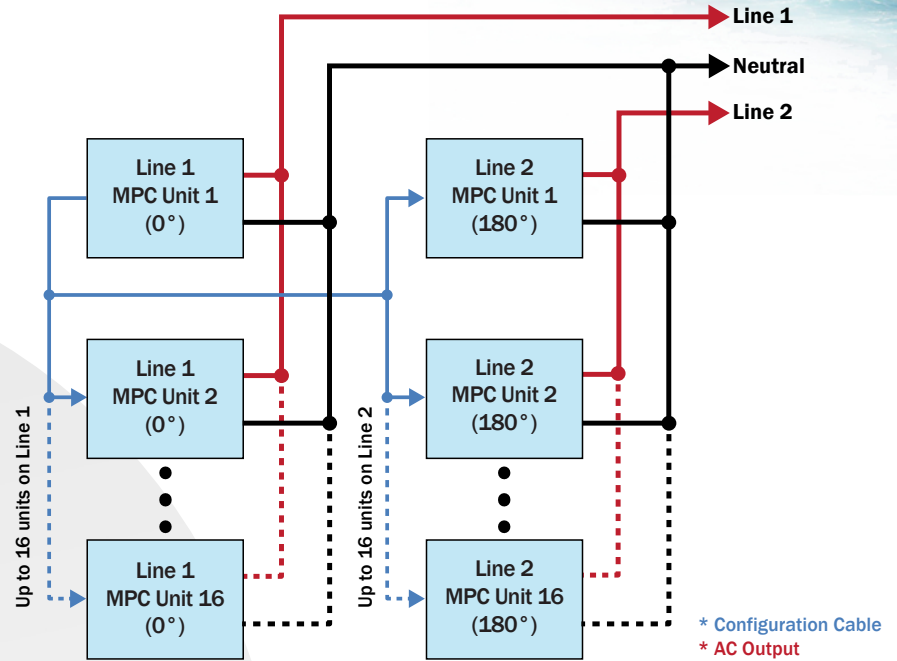

### 3-Phase Output System (Y - Connection Only)

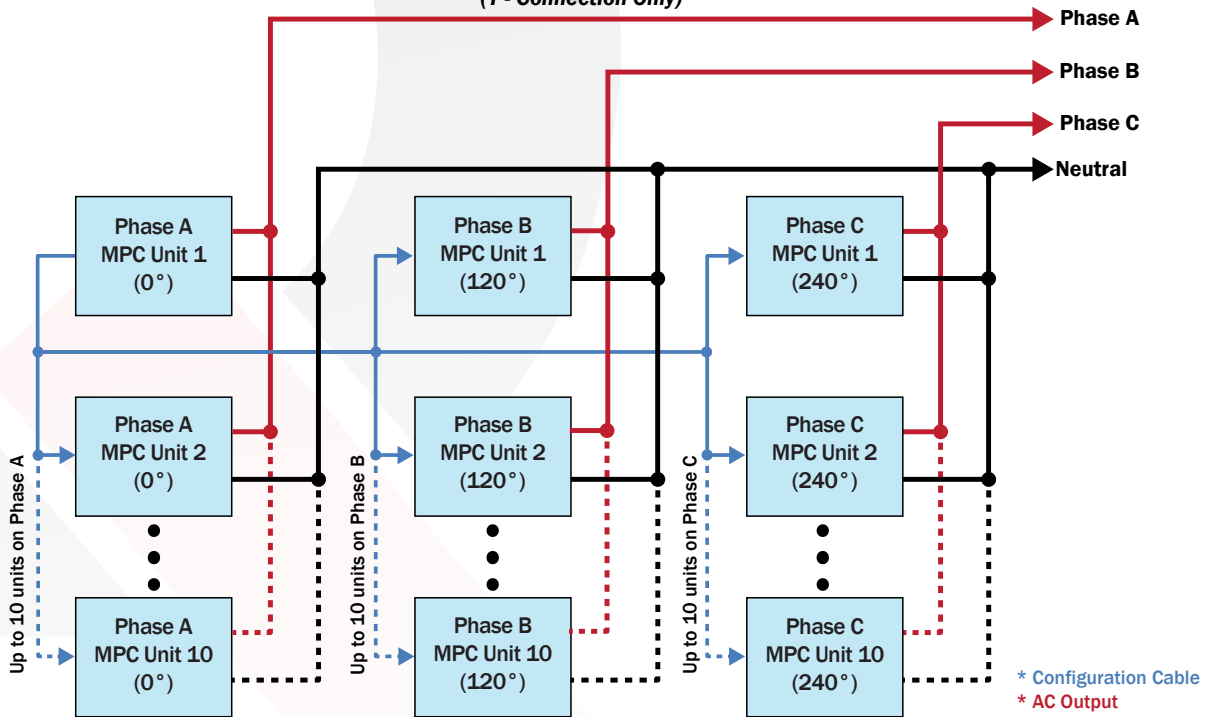

\*Contact factory for system specific configuration cables.

## MPC-1500-1S



## MPC-1500-1S with DC Input / DC1 Output Option



## MPC-1500-1S with DC1 Output / DC2 Output Option

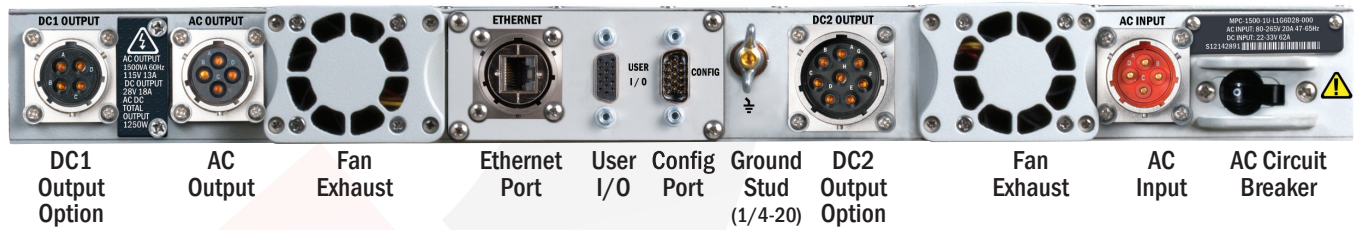



**MPC MILITARY FIELD-GRADE**  
**MPC-1500-1S**

Mechanical Diagrams

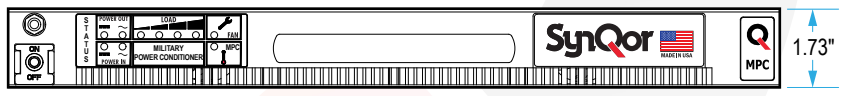
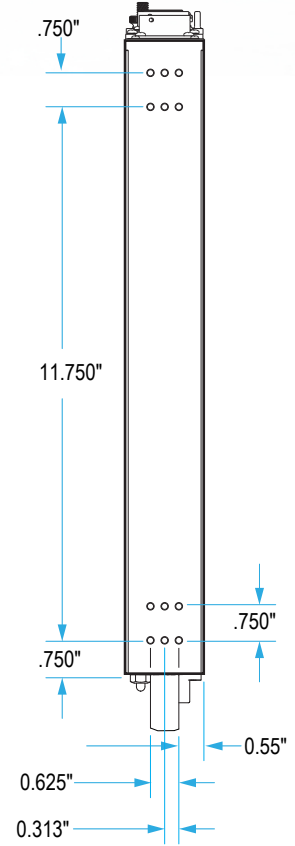
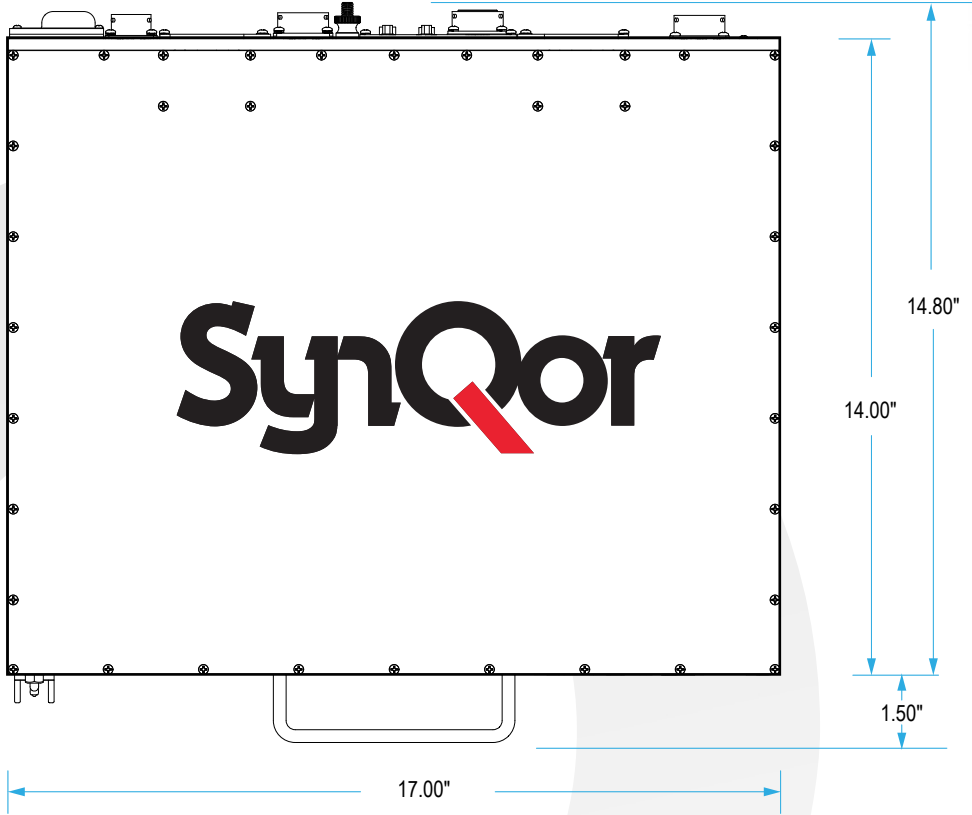

**Note:**  
 1) ALL DIMENSIONS IN INCHES [mm]  
 TOLERANCES: X.XXIN +/- 0.02 [0.5]  
 X.XXXIN +/- 0.010 [0.25]



## Accessory Options

### Rail Kits

Fixed Bracket Kit <sup>2</sup>	SYN-9055
<b>Power Cables (10' long)</b>	
AC Input (NEMA 5-20 Plug)	SYN-9101
AC Input (NEMA 5-15 Plug)	SYN-9104
AC Input (Hardwire)	SYN-9102
AC Output (115Vrms) (NEMA 5-20 Receptacle)	SYN-9131
AC Output (Hardwire)	SYN-9130
DC Input (Ring Connectors)	SYN-9151
DC Input (Hardwire)	SYN-9152
DC Input (NATO Connector)	SYN-9154
DC1 Output (Fork Connectors)	SYN-9171
DC1 Output (Hardwire)	SYN-9172
DC2 Output (Hardwire)	SYN-9174
DC2 Output (Fork Connectors)	SYN-9175
<b>AC Output Power Strips (Circular Connector)</b>	
6 NEMA Receptacles with Breaker (1U Rackmount & 3' Cable)	SYN-9232
6 NEMA Receptacles (1U Rackmount & 3' Cable)	SYN-9231
<b>Rackmount Transit Cases</b>	
Transit Case, 3U, Gray, with Casters <sup>2</sup>	SYN-9410
Transit Case, 3U, Gray, No Casters <sup>2</sup>	SYN-9412

#### Notes:

- 1: Other Options also available, check the website or contact [power@synqor.com](mailto:power@synqor.com) for further information.
- 2: Fixed Bracket Kit (SYN-9055) is required for transit and ruggedized use.



Optional Rackmount Transit Case



6 NEMA Receptacles with Breaker

User Communications (I/O) Cables	
HD DB15M to DB9F (RS232, 10')	SYN-9301
HD DB15M to DB15M (RS232 and Digital I/O, 10')	SYN-9305
Mil-Circular to RJ45 (Ethernet, 10')	SYN-9321
Configuration Cables (AC Output Sharing Only)	
HD DB15F to DB15F (2 Units Parallel, 3')	SYN-9311
HD DB15F to DB15F (3 Units Parallel, 6')	SYN-9315
HD DB15F to DB15F (2 Units Series, 3')	SYN-9313
HD DB15F to DB15F (3 Units 3 Phase, 6')	SYN-9317
R-Option Configuration Cables (AC Output Sharing Only)*	
HD DB15F to DB15F (2 Units, Expanded Paralleling, 3')	SYN-9341
HD DB15F to DB15F (3 Units, Expanded Paralleling, 6')	SYN-9343



\* Contact factory for additional configuration cables.



# Ordering Information

Base Model			
Model Number	Power	Height (W x D x H)	Weight
<b>MPC-1500-1S</b>	<b>1250 W 1500 VA</b>	<b>1U (17.00" x 14.80" x 1.73")</b>	<b>22 lbs.</b>

Base Model	Options							Options	
	AC Input Freq	AC Output Voltage	AC Output Neutral Wire	AC Output Set Point Freq	DC Input / DC2 Output	DC1 Output	Additional Options	AC Input Freq	AC Output Voltage
<b>MPC-1500-1S</b>	L W	1 2	G F R	5 6 4	S D M P R V W Y	00 12 15 24 28 40 50	-E 00 CE	L W	1 2

Not all combinations make valid part numbers, please contact SynQor for availability. See the Product Summary web page for more options.

**\*Notes:**

Order "F: Floating" option when configuring the AC output for multi-unit combinations of up to 3 units.

Order "R: AC Output Electronic Breaker" option for fault-tolerant, glitch-free parallel systems of up to 32 units with N+M redundancy. The AC output neutral wire will not be connected to the chassis.

**Examples:**

**MPC-1500-1S-L1G6D28-E00,**  
**MPC-1500-1S-L1F4S00-ECE**

<b>AC Input Freq</b>	L 47-65 Hz W 47-800 Hz
<b>AC Output Voltage</b>	1 115 Vrms 2 230 Vrms
<b>AC Output Neutral Wire</b>	G Grounded F Floating* R AC Output Electronic Breaker*
<b>AC Output Set Point Freq</b>	5 50 Hz 6 60 Hz 4 400 Hz
<b>DC Input / DC2 Output</b>	S Not Installed D DC Input M DC2 Out 24 VDC with Droop Share P DC2 Out 24 VDC No Share R DC2 Out 28 VDC with Droop Share V DC2 Out 28 VDC No Share W DC2 Out 50 VDC No Share Y DC2 Out 50 VDC with Droop Share
<b>DC1 Output</b>	00 None 12 12 V 15 15 V 24 24 V 28 28 V 40 40 V 50 50 V
<b>Additional Options</b>	-E Ethernet/SNMP with Configuration Loading 00 No CE Marking CE CE Marking

**Contact SynQor for further information and to order:**

Phone: 978-849-0600 Fax: 978-849-0602  
E-mail: power@synqor.com Web: www.synqor.com  
Address: 155 Swanson Road, Boxborough, MA 01719 USA

**WARRANTY**

SynQor offers a one (1) year limited warranty. Complete warranty information is listed on our website or is available upon request from SynQor.

**PATENTS**

SynQor holds numerous U.S. patents, one or more of which apply to most of its power conversion products. Any that apply to the product(s) listed in this document are identified by markings on the product(s) or on internal components of the product(s) in accordance with U.S. patent laws. SynQor's patents include the following:

7,765,687 7,787,261  
8,149,597 8,644,027