

www.ergotron.com



User's Guide - English
Guía del usuario - Español
Manuel de l'utilisateur - Français
Gebruikersgids - Deutsch
Benutzerhandbuch - Nederlands
Guida per l'utente - Italiano
Användarhandbok - svenska
ユーザーガイド : 日本語
用户指南 : 汉语



www.ergotron.com

USA 1-800-888-8458

Europe +31 (0)33-45 45 600

China 86-769-86018920

For the latest User Installation Guide please visit: www.ergotron.com

For service and warranty visit www.ergotron.com

For local customer care phone numbers visit: <http://contact.ergotron.com>

Warning: Because mounting surface materials can vary widely, it is imperative that you make sure mounting surface is strong enough to handle mounted product and equipment.

Adjust the height of your desk (or chair and footrest) to allow the keyboard to lower to your sitting elbow height for ergonomic computing.

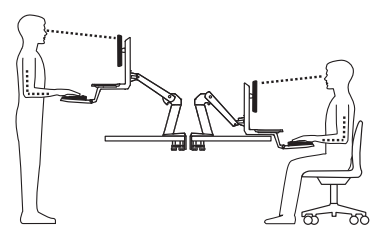
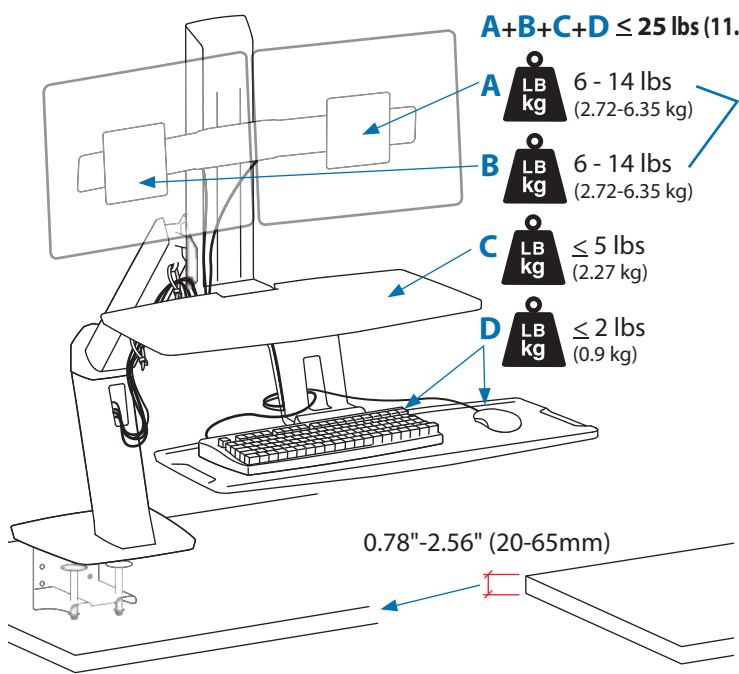

Important! You will need to adjust this product after installation is complete. Make sure all your equipment is properly installed on the product before attempting adjustments. This product should move smoothly and easily through the full range of motion and stay where you set it. If movements are too easy or difficult or if product does not stay in desired positions, follow the adjustment instructions to create smooth and easy movements. Depending on your product and the adjustment, it may take many turns to notice a difference. Any time equipment is added or removed from this product, resulting in a change in the weight of the mounted load, you should repeat these adjustment steps to ensure safe and optimum operation.

ENGLISH

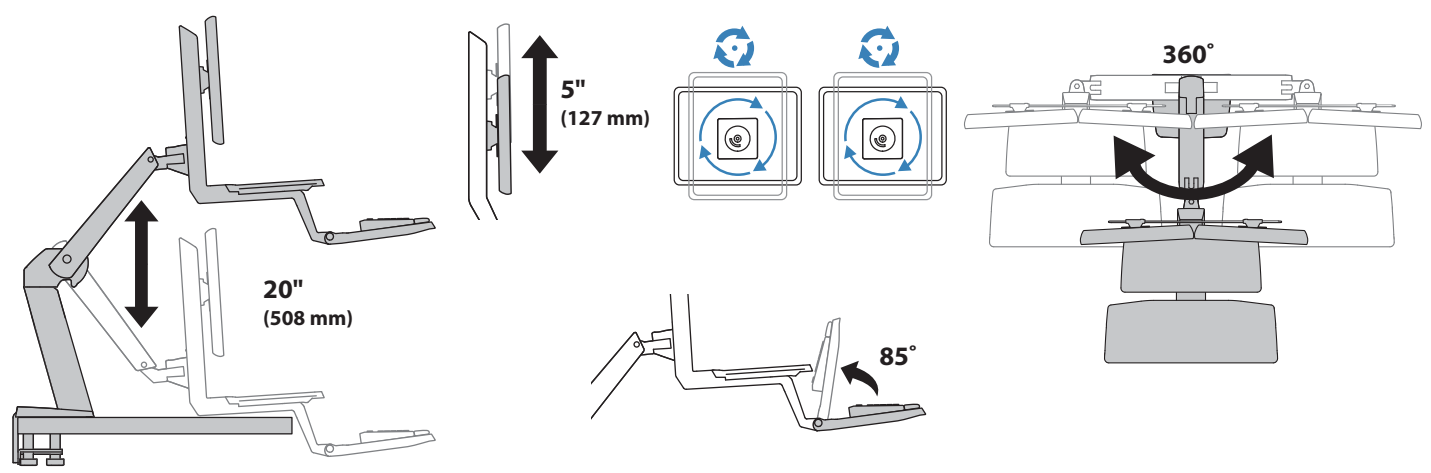
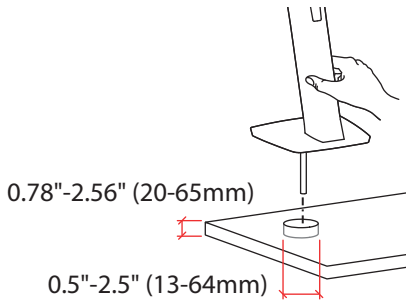

Set Your Workstation to Work For YOU!

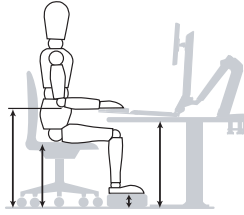

Learn more about ergonomic computer use at:
www.computingcomfort.org

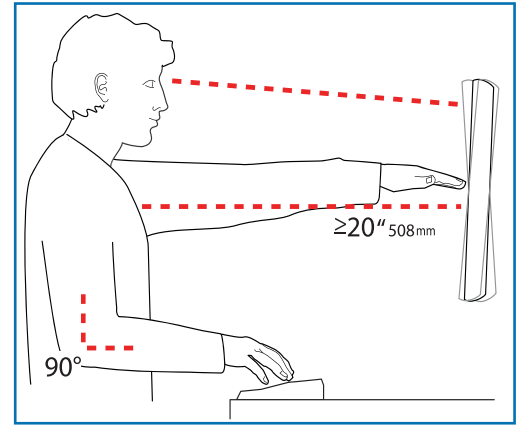

- Height** Position top of screen slightly below eye level.
- Distance** Position keyboard at about elbow height with wrists flat.
- Distance** Position screen an arm's length from face—at least 20" (508mm).
- Distance** Position keyboard close enough to create a 90° angle in elbow.
- Angle** Tilt screen to eliminate glare.
- Angle** Tilt the keyboard back 10° so that your wrists remain flat.

- To Reduce Fatigue**
- Breathe - Breathe deeply through your nose.
- Blink - Blink often to avoid dry eyes.
- Break - 2 to 3 minutes every 20 minutes
- 15 to 20 minutes every 2 hours.



	A	B	C	D	E	F
1	1x	1x	1x	1x	2x	12x
2	1x					8x
3	1x			2x		
4	1x 1x 1/4"	1x		4x		2x
5	2x	2x	4x	1x 4 mm		8x
6	1x			2x		
7	1x	2x	1x	1x	1x	

ENGLISH

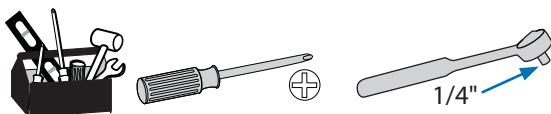

1 Arm Extension and Desk Size:

The keyboard tray is designed to extend over the edge of your desk. You can expand the extension of the arm if you need to based on your desk size. To determine if you need to expand your arm extension, refer to the 4 desk dimensions below:

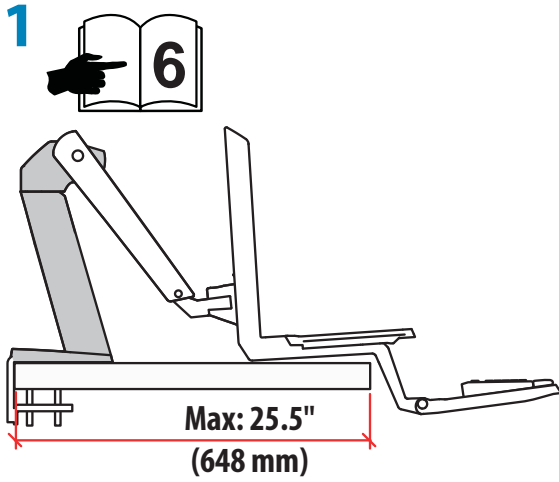

CLAMP

2 Expand Arm Extension

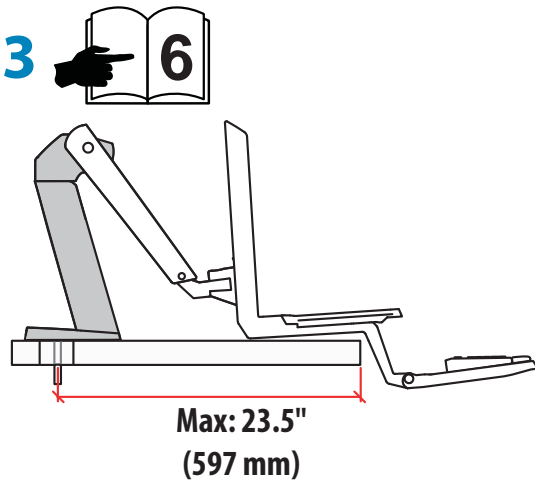
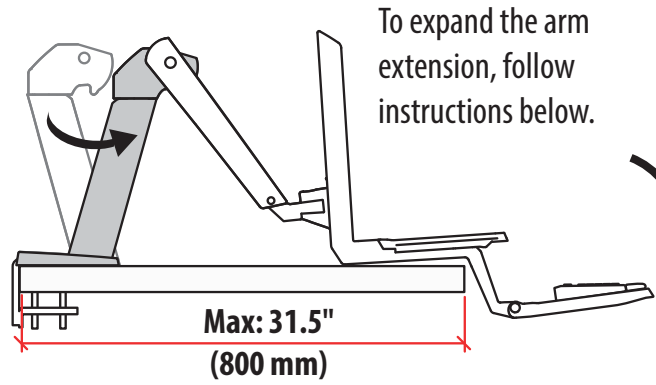

GROMMET HOLE

4 Expand Arm Extension

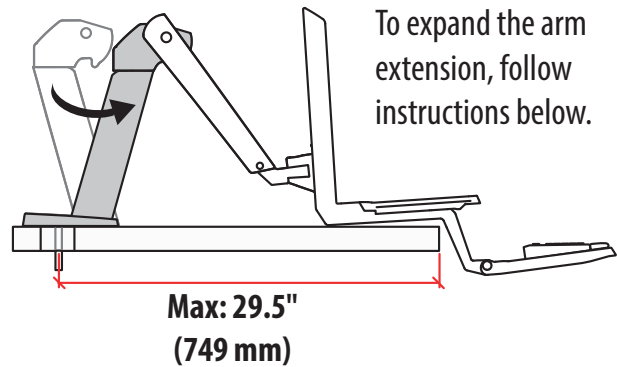

How to expand the arm extension.

a Remove the 4 screws at the base using the provided 4mm hex wrench.

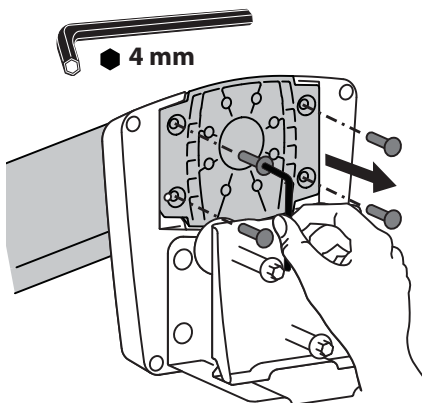

b Flip the base around (turn 180 degrees).

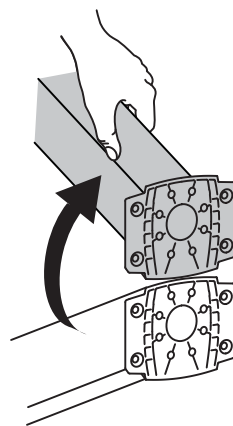

c Re-insert the 4 screws and tighten with the 4mm hex wrench.

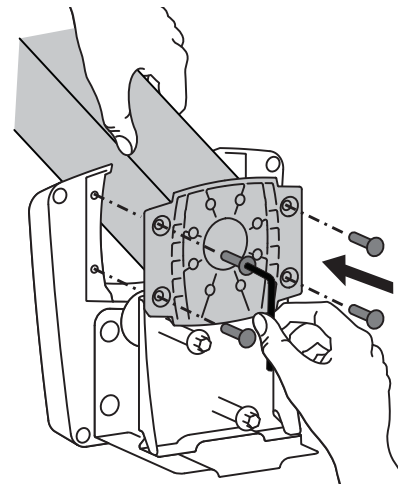

2

CLAMP

GROMMET HOLE

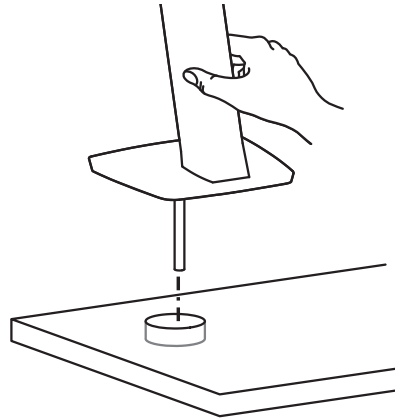
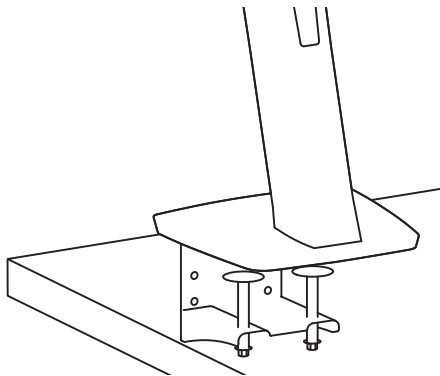

DESK THICKNESS

0.78"-1.78" (20-45mm)

1.70"-2.56" (43-65mm)

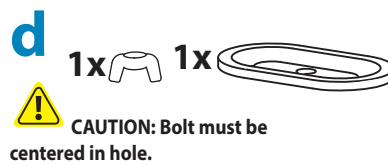
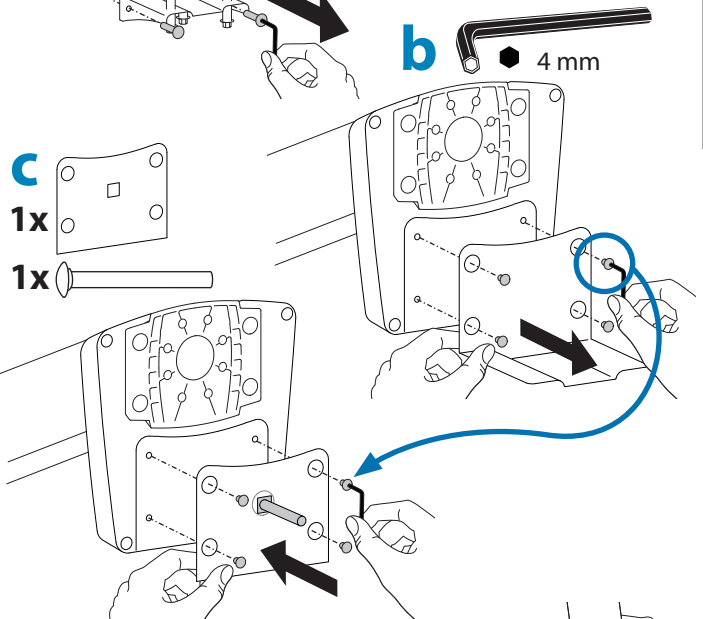
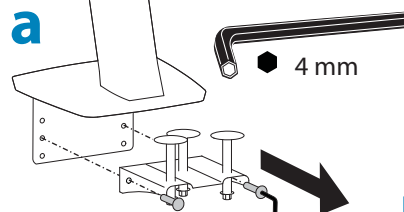
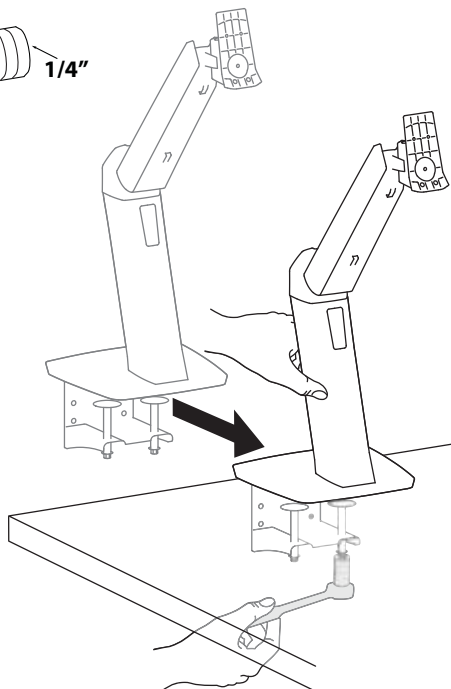
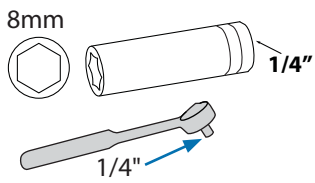
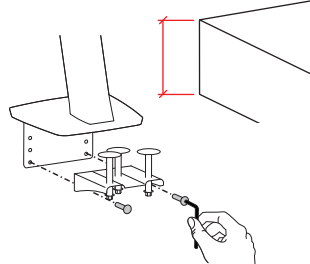
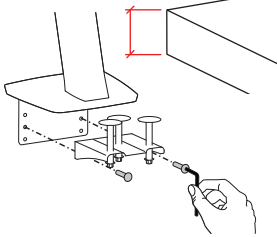

3 a

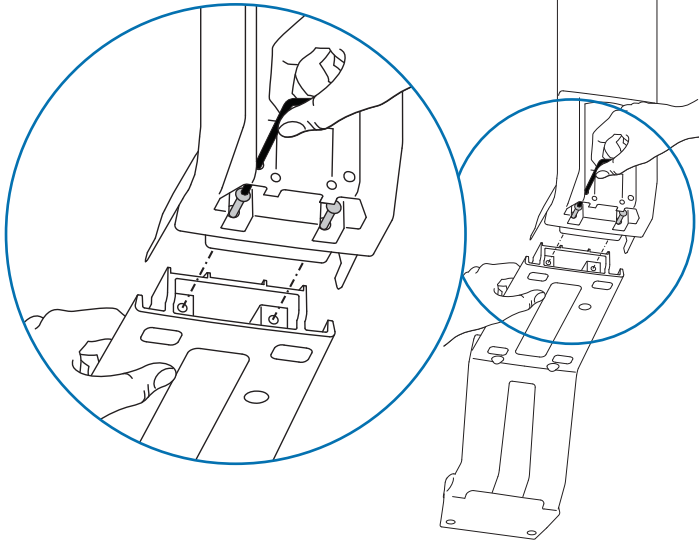
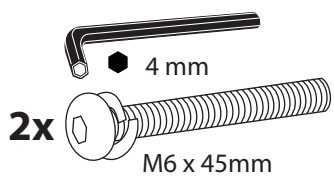

b

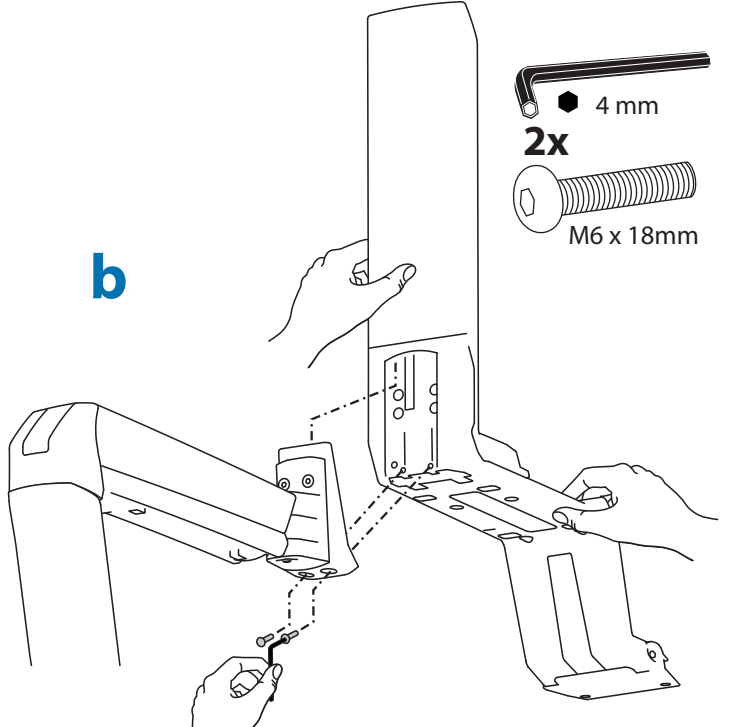
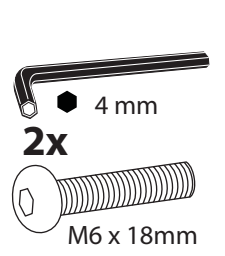

4 a

1x

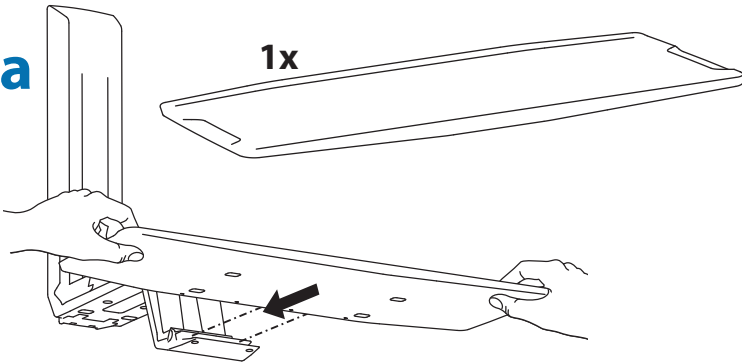

b

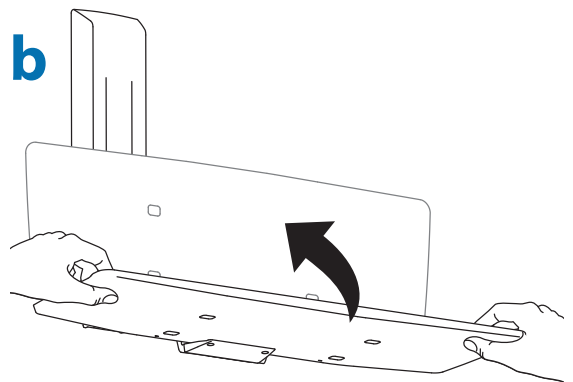

c 2x M4x16mm

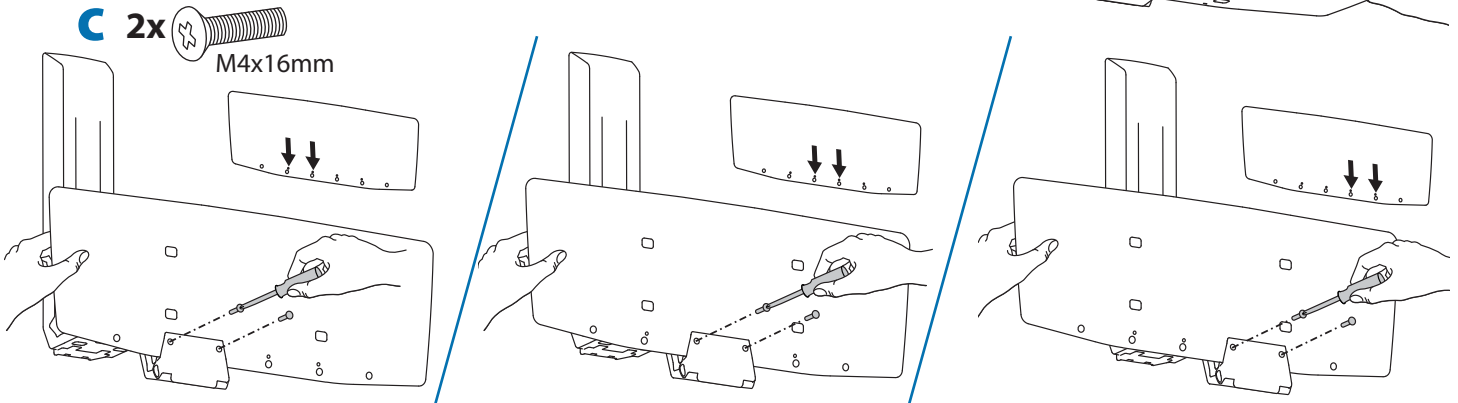

5

4 mm
4x M6 x 6mm

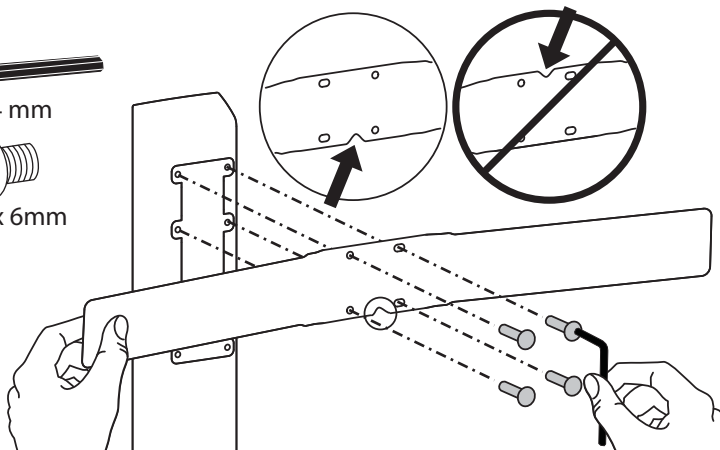

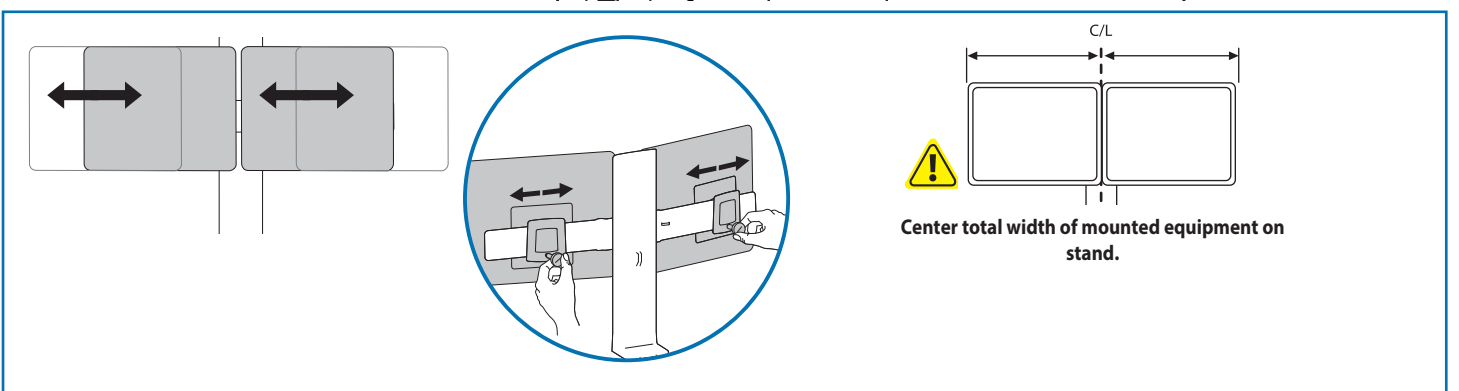
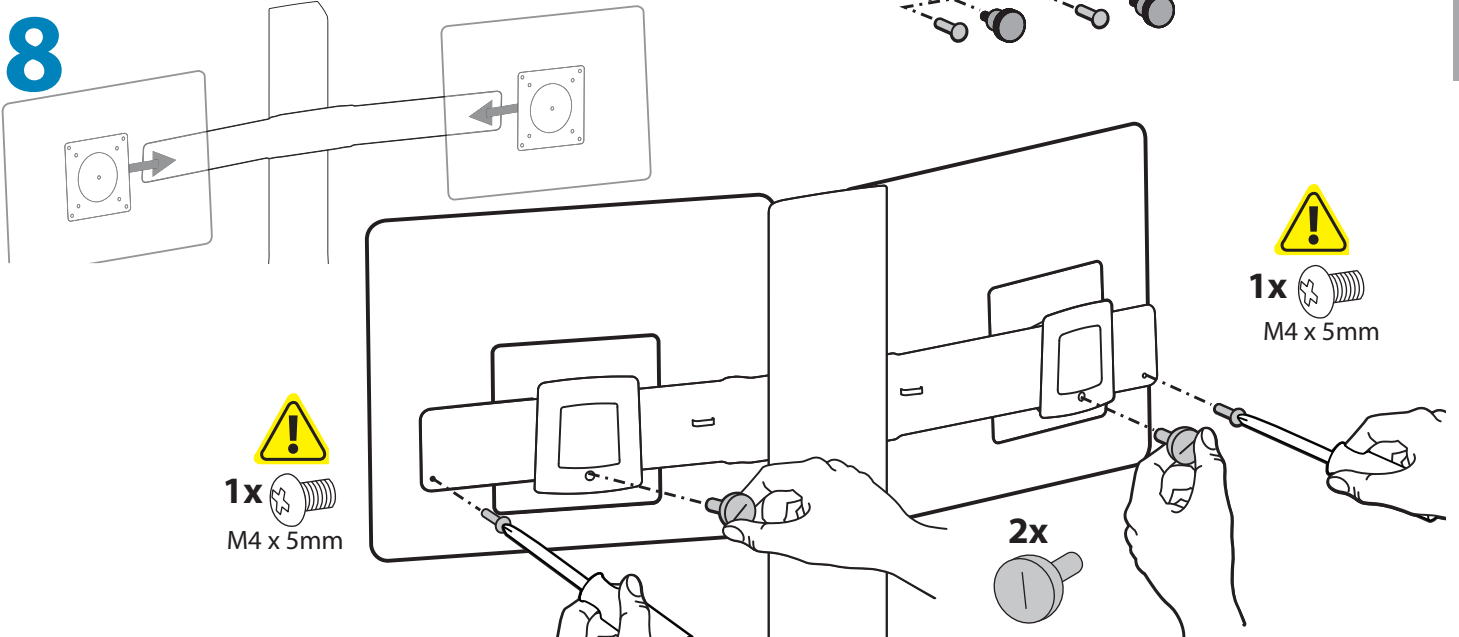
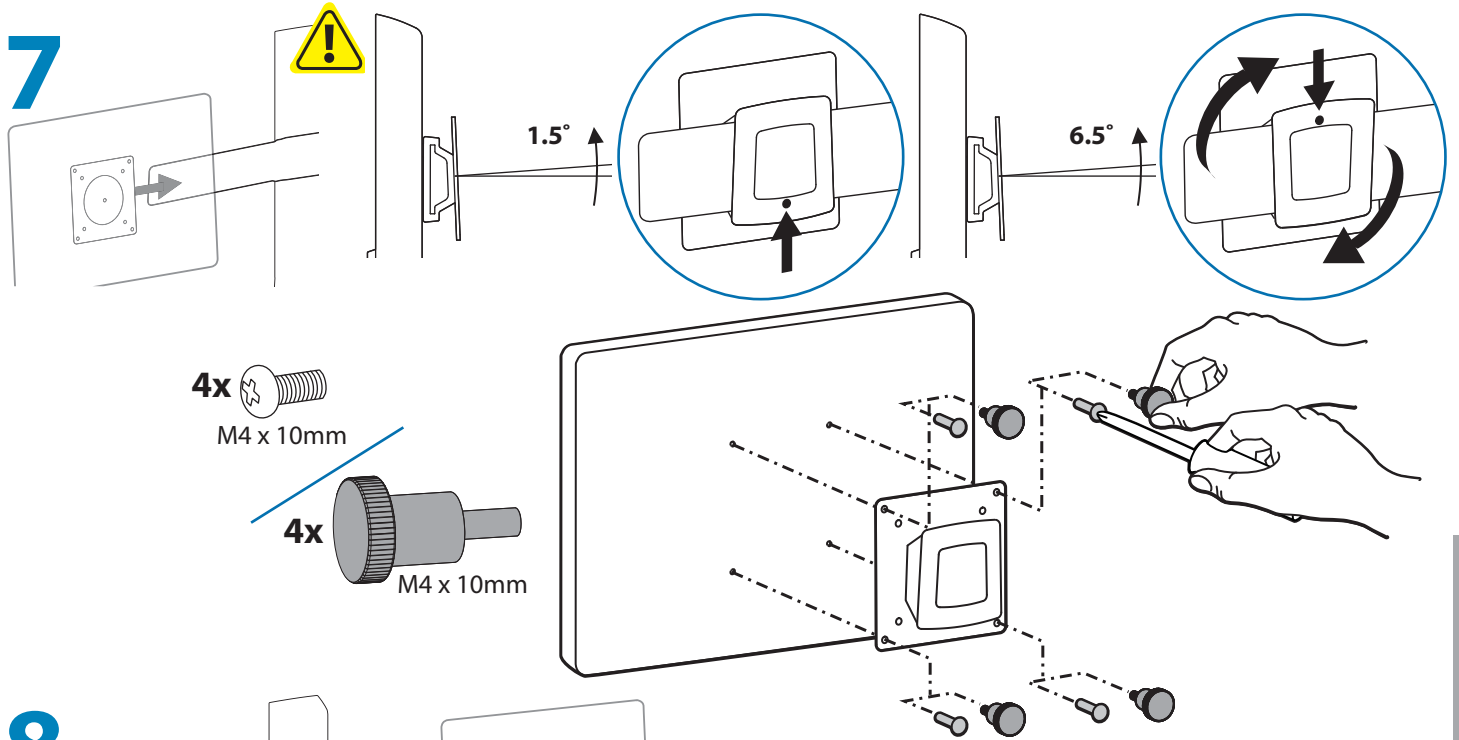
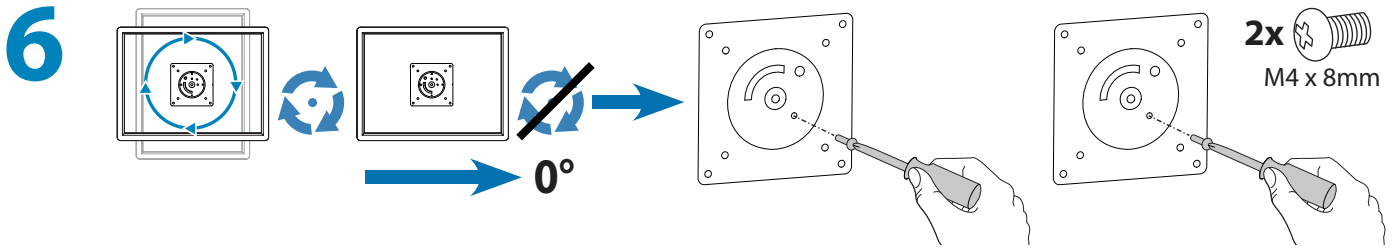

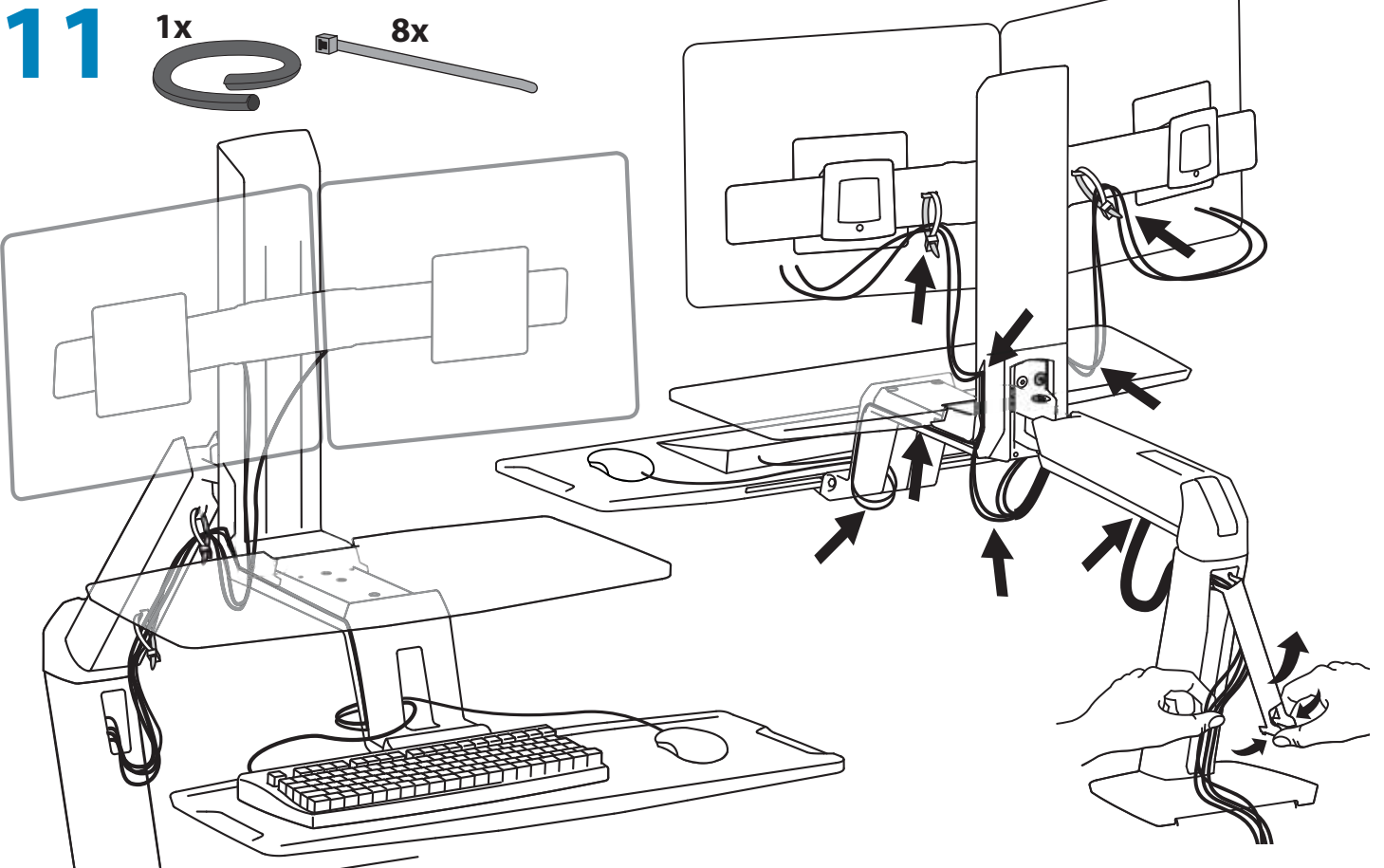
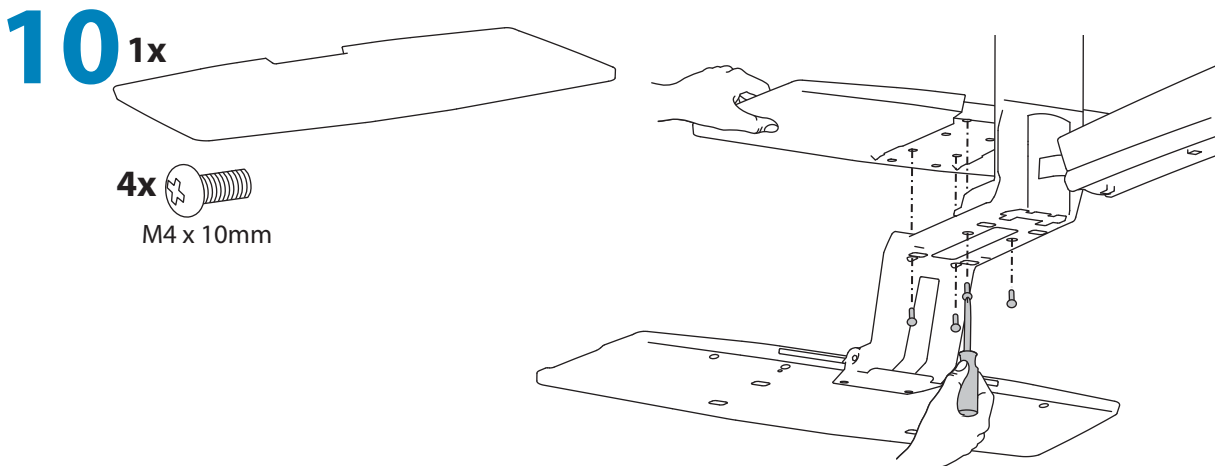
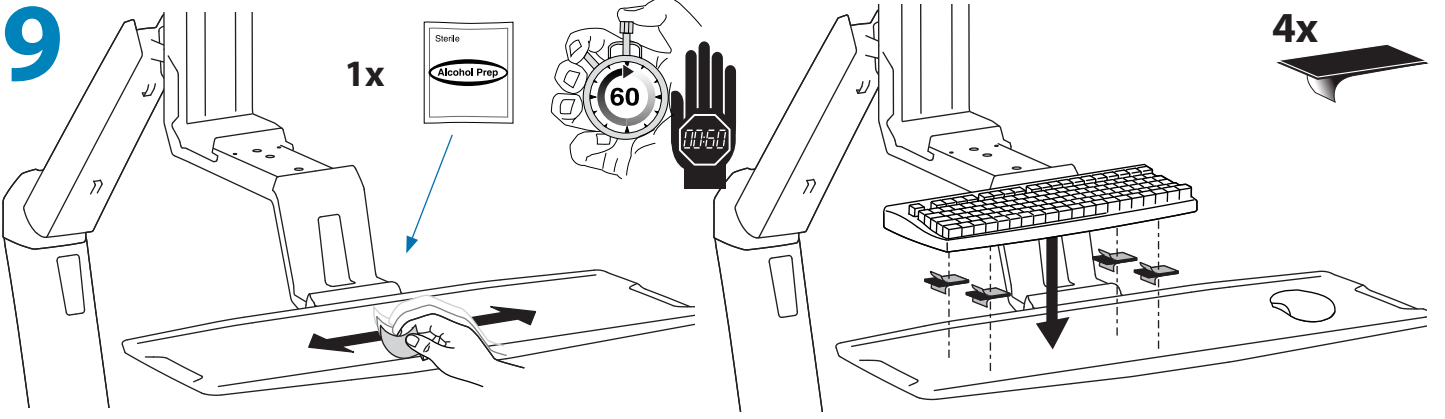

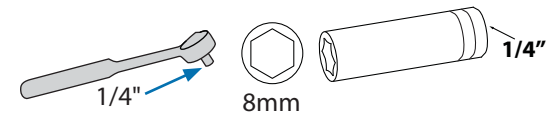
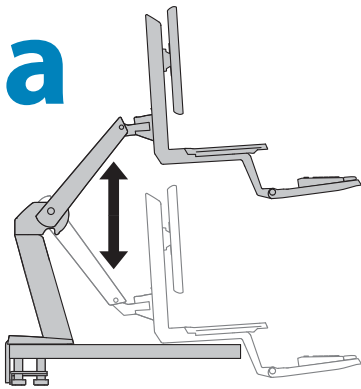

12 Adjustment Step

Important! You will need to adjust this product after installation is complete. Make sure all your equipment is properly installed on the product before attempting adjustments. This product should move smoothly and easily through the full range of motion and stay where you set it. If movements are too easy or difficult or if product does not stay in desired positions, follow the adjustment instructions to create smooth and easy movements. Depending on your product and the adjustment, it may take many turns to notice a difference. Any time equipment is added or removed from this product, resulting in a change in the weight of the mounted load, you should repeat these adjustment steps to ensure safe and optimum operation.



+  **LB kg** **Increase Lift Strength**
 If the mounted weight is too heavy or this product does not stay up when raised, then you'll need to increase Lift Strength:

-  **LB kg** **Decrease Lift Strength**
 If the mounted weight is too light or this product does not stay down when lowered, then you'll need to decrease Lift Strength:

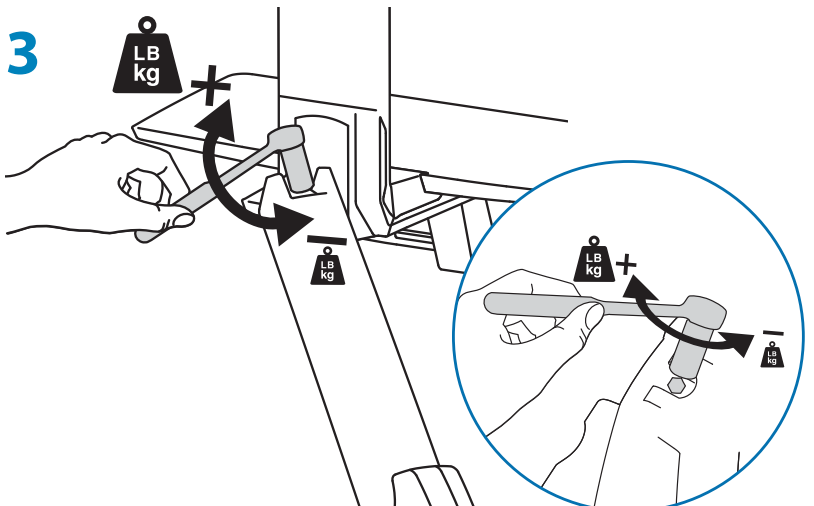
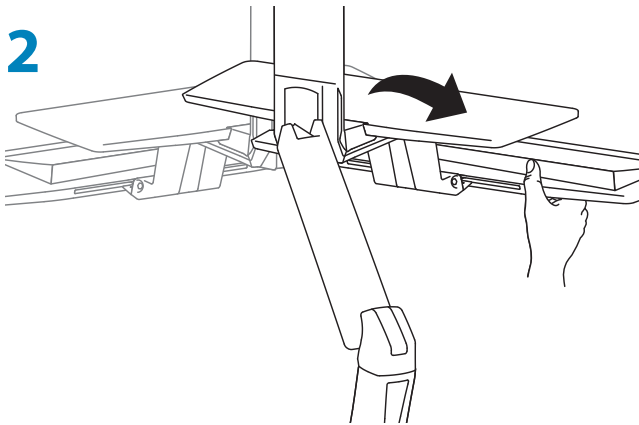
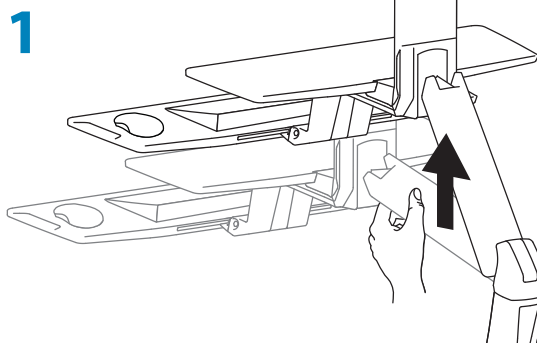

b

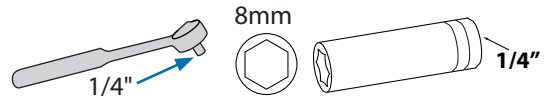
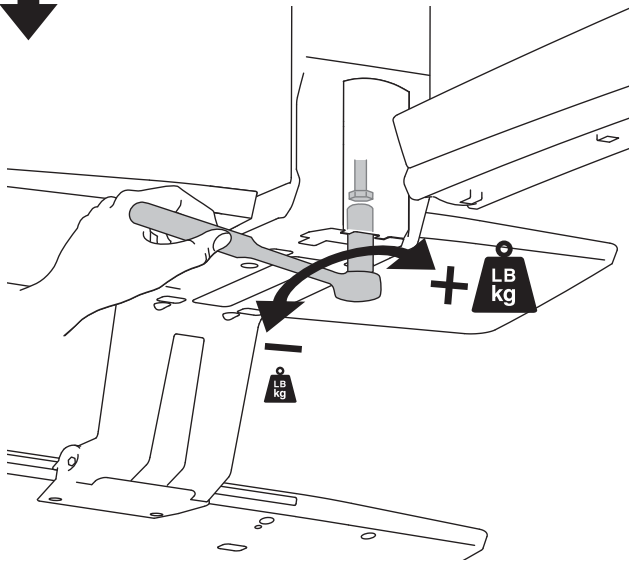
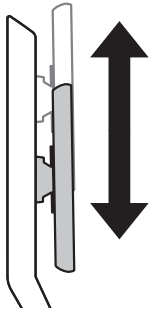

+ **LB kg**
Increase Lift Strength
If the mounted weight is too heavy or this product does not stay up when raised, then you'll need to increase Lift Strength:

- **LB kg**
Decrease Lift Strength
If the mounted weight is too light or this product does not stay down when lowered, then you'll need to decrease Lift Strength:

ENGLISH

c

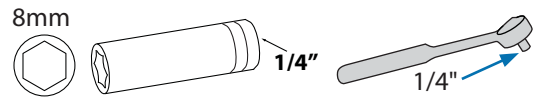
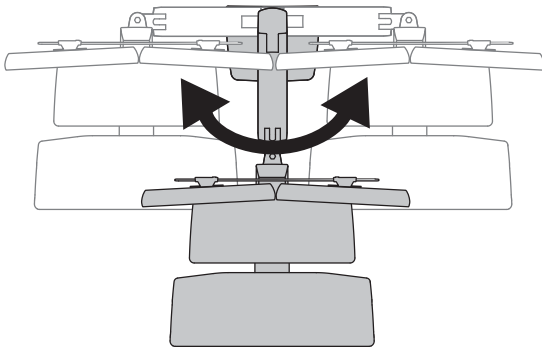

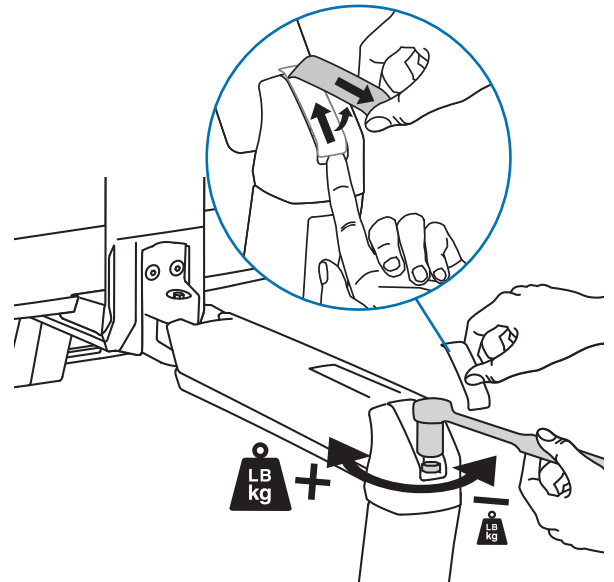
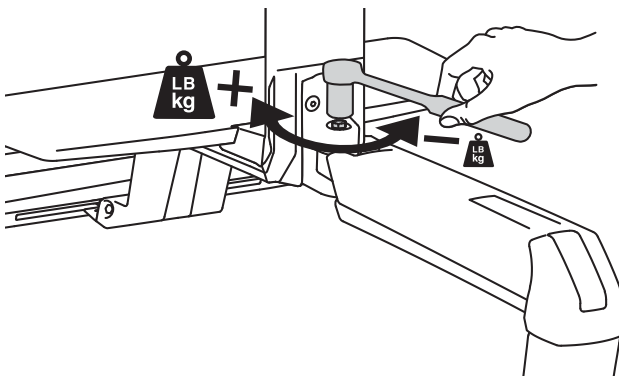

+ **LB kg**
Increase Friction
If this product moves too easily from side-to-side, then you'll need to increase friction:

- **LB kg**
Decrease Friction
If this product is too difficult to move from side-to-side, then you'll need to decrease friction:

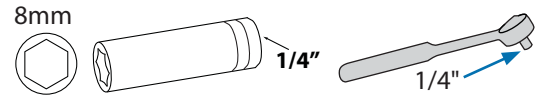
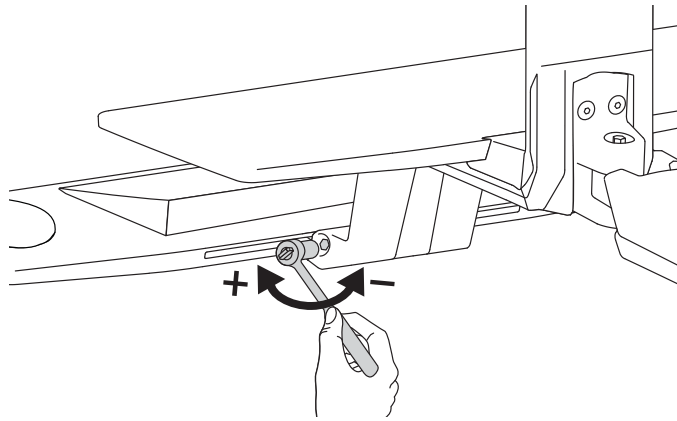
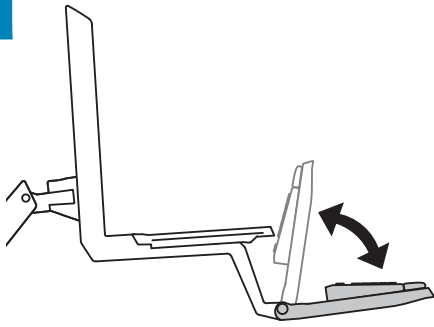

d





+  **LB kg** **Increase Friction**
If this product moves too easily from side-to-side, then you'll need to increase friction:

-  **LB kg** **Decrease Friction**
If this product is too difficult to move from side-to-side, then you'll need to decrease friction:

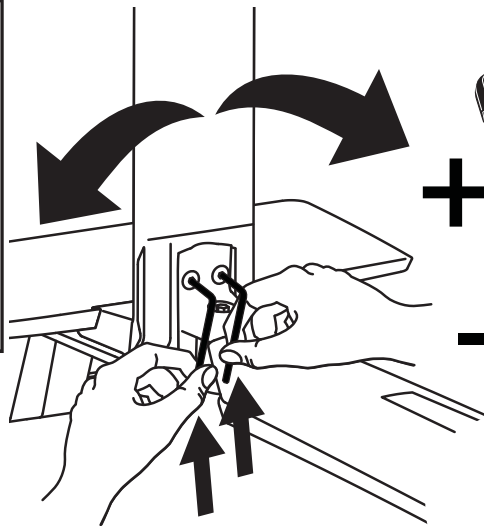
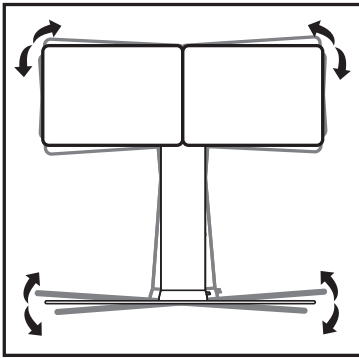
e



+  **LB kg** **Increase Friction**
If this product moves too easily from side-to-side, then you'll need to increase friction:

-  **LB kg** **Decrease Friction**
If this product is too difficult to move from side-to-side, then you'll need to decrease friction:



© 2013 Ergotron, Inc.
All rights reserved.

While Ergotron, Inc. makes every effort to provide accurate and complete information on the installation and use of its products, it will not be held liable for any editorial errors or omissions (including those made in the process of translation from English to another language), or for incidental, special or consequential damages of any nature resulting from furnishing this instruction and performance of equipment in connection with this instruction. Ergotron, Inc. reserves the right to make changes in the product design and/or product documentation without notification to its users. For the most current product information, or to know if this document is available in languages other than those herein, please contact Ergotron. No part of this publication may be reproduced, stored in a retrieval system, or transmitted in any form or by any means, electronic, mechanical, photocopying, recording or otherwise without the prior written consent of Ergotron, Inc., 1181 Trapp Road, Eagan, Minnesota, 55121, USA Patents Pending and Patented U.S. & Foreign. Ergotron is a registered trademark of Ergotron, Inc.

Americas Sales and Corporate Headquarters

St. Paul, MN USA
(800) 888-8458
+1-651-681-7600
www.ergotron.com
sales@ergotron.com

EMEA Sales

Amersfoort, The Netherlands
+31 33 45 45 600
www.ergotron.com
info.eu@ergotron.com

APAC Sales

Tokyo, Japan
www.ergotron.com
apaccustomerservice@ergotron.com

Worldwide OEM Sales

www.ergotron.com
info.oem@ergotron.com