



Ducted Systems Technical Services Service Tips Letter

Letter: **STR-005-24**

Date: August 14th, 2024

To: All Ducted Systems Branch Service, Sales, and Training Managers
All Ducted Systems Distribution Service, Sales, and Training Managers

Subject: **ECM Outdoor fan motor – Wolong brand. Field diagnostics and part replacement.**

Product: AC19B, AL19B, YXT, CC7B, TC7B, RAC17, YCG, TCG, CC17B, TC17B, YFK, TCF2B, RAC15, YC2F, HC19B, HL19B, YZT, THF2B, RHP15, YH2F, TH4B, RHP14L, YHE, THE, CH6B, TH6B, RHP16L, YHG,

The intention of this letter is to assist with field diagnostics of Wolong brand outdoor ECM fan motors and controllers and advise on part(s) replacement after field testing.

The use of ECM outdoor fan motors, until about 5 years ago, was mainly reserved for premium tier outdoor equipment such as HC8B, HL8B, YZH, etc. As system efficiency standards have changed, the use of ECM outdoor fan motors has become more of the normal, being used on single stage mid-tier equipment. Our first mid-tier equipment models were CC7B, TC7B, RAC17, and YCG. These models were launched using a Regal 142R ECM outdoor fan motor with remote mounted controller / module. The Regal ECM motor, although 2 separate pieces (motor and controller) was only offered by Regal as one service part meaning motor and controller were sent together any time a failure occurred, and a replacement part was ordered.

Due to a higher-than-normal number of failures, an alternate vendor and motor model was selected and tested to replace the Regal 142R ECM outdoor fan motor. The alternate vendor is Wolong and EM42 series motor. This motor was implemented in late 2020 to all residential products that were using the Regal 142R ECM outdoor fan motor. Details of this change were communicated in service letter YS-008-20. As failure rates were monitored and warranty part returns were analyzed at the CWE (Center of Warranty Excellence) it was observed that some motors were failing due to corrosion of internal parts. Although a protective coating (rust inhibitor) was already part of the normal motor manufacturing process, some rust and bearing failure was noted. There was a continuous improvement effort implemented into Wolong ECM motor production on September 13th, 2022. The improvement is an O-ring seal between the end cap and motor case. The photo to the right shows the O-ring inside the motor case. The improvement was announced on May 9th, 2023, in service letter ST-013-23. The service motor part number is S1-02440880000, and part number did not change when the O-ring improvement was made. Replacement motors with the O-ring improvement arrived at Source 1 on 11/09/2022 and material shipped after that date contain the O-ring improvement.

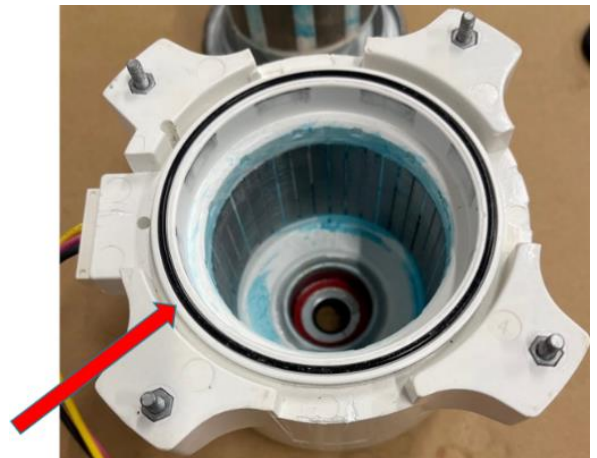

The Wolong ECM outdoor fan motor consists of a motor and programmed controller. We currently offer kits containing both the motor and controller. These kits are **ONLY** intended for and needed when replacing a Regal 142R ECM outdoor fan motor with a Wolong ECM outdoor fan motor. This is due to the different branded parts not being interchangeable with each other, meaning if the Regal fan motor fails, a Wolong motor cannot be used unless the Wolong controller is also installed. The Wolong ECM outdoor fan motor we currently use is actually the same motor across the entire product lines regardless of model capacity, however the program on the motor controller is different depending on model capacity and what was specified. There are a total of five motor controllers and one motor.

- S1-02442223000 CONTROLLER, COND,1/3 HP,682RPM,208/230V
- S1-02442224000 CONTROLLER, COND,1/3 HP,834RPM,208/230V
- S1-02442225000 CONTROLLER, COND,1/3 HP,875RPM,208/230V
- S1-02442226000 CONTROLLER, COND,1/3 HP,917RPM,208/230V
- S1-02440885000 CONTROLLER, COND,1/3 HP,PWM,208/230V
- S1-02440880000 MTR,COND,NO CONTROLLER,1/3 HP,208/230V

Four of the controllers have a fixed speed and one has a PWM (Pulse Width Modulating) input to vary the speed of the outdoor fan motor based on control board output. The PWM controller is only used on certain premium model outdoor equipment.

On equipment built with the Wolong ECM outdoor fan motor, a kit should **not** be used for unit repair. One of the above part numbers will be required for unit repair when an outdoor fan motor fails to operate assuming both LINE voltage and LOW voltage (or control signal) is present. Either the controller has failed, or the outdoor fan motor itself has failed. This strategy of separate parts will cut down on the number of parts stocked as well as less time performing an equipment repair.

Testing the controller is currently limited to testing its inputs. When performing a field test, the controller should always have LINE voltage regardless of an active call for cooling or heat pump heating. On most air-conditioning and heat pump models, test for LINE voltage between the controller BLK and RED input leads at locations shown below. Acceptable LINE voltage can range from 187 to 262 VAC.

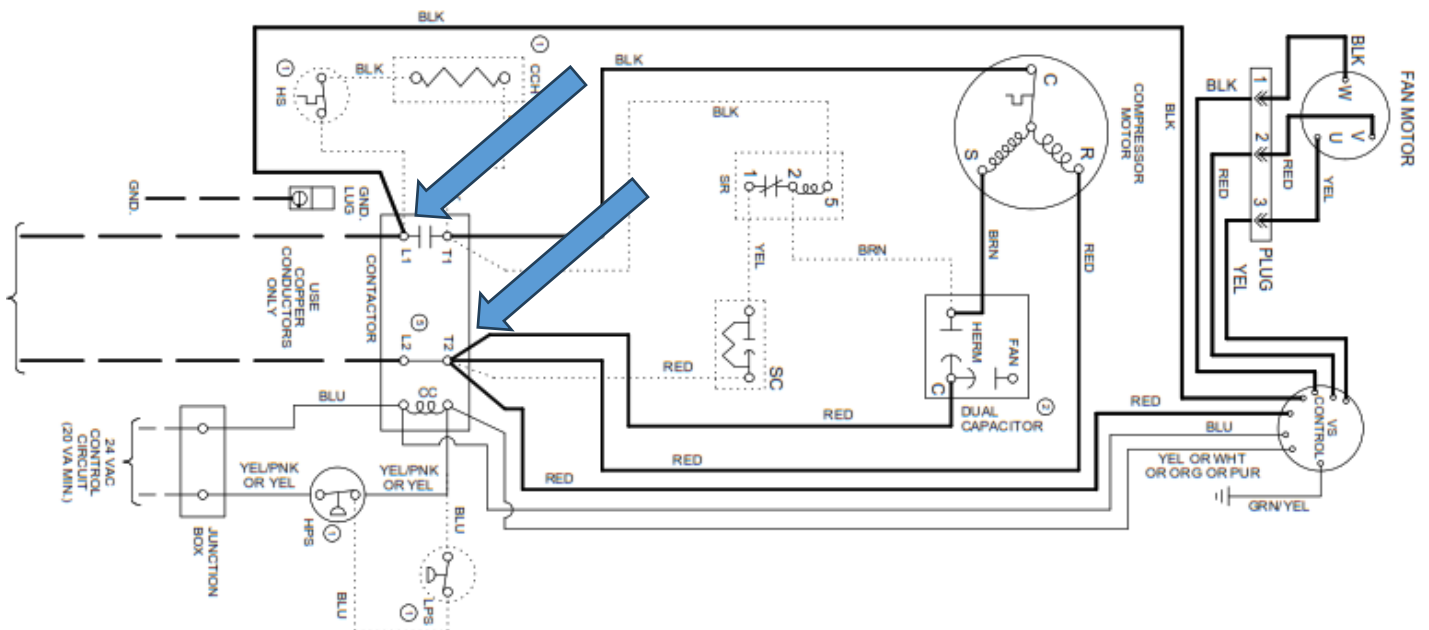

Next test is to check the control signal input to the motor controller. This must be done with an active cooling call. On a non-premium air conditioning unit, the motor controller control voltage input is typically wired in parallel with the outdoor unit compressor contactor low voltage. Test for 24V A/C at the locations shown below.

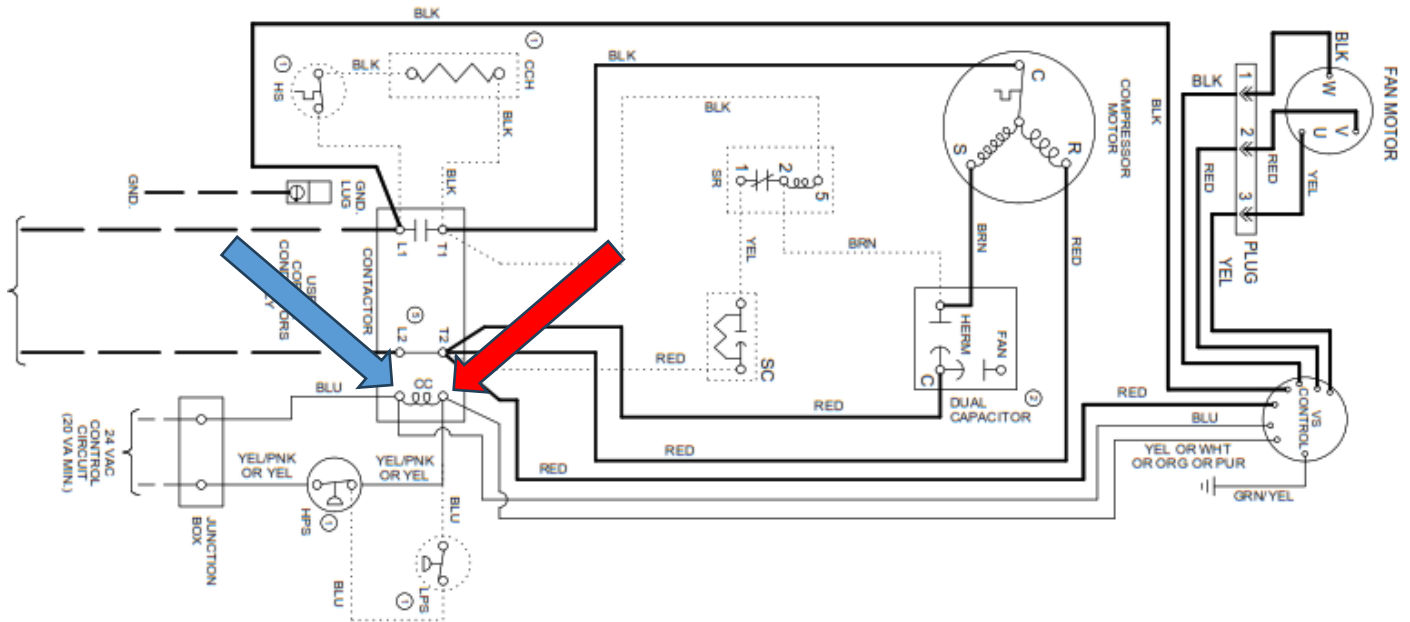

Some non-premium air-conditioning models have the motor controller control voltage wired in parallel with the incoming 24V A/C control voltage prior to connection with the contactor and the high and / or low-pressure switch. Using this wiring strategy, the outdoor fan motor should continue to operate even if a high-pressure event should occur, and the high pressure switch interrupted control voltage to the unit contactor. Test for 24V A/C at the locations shown below.

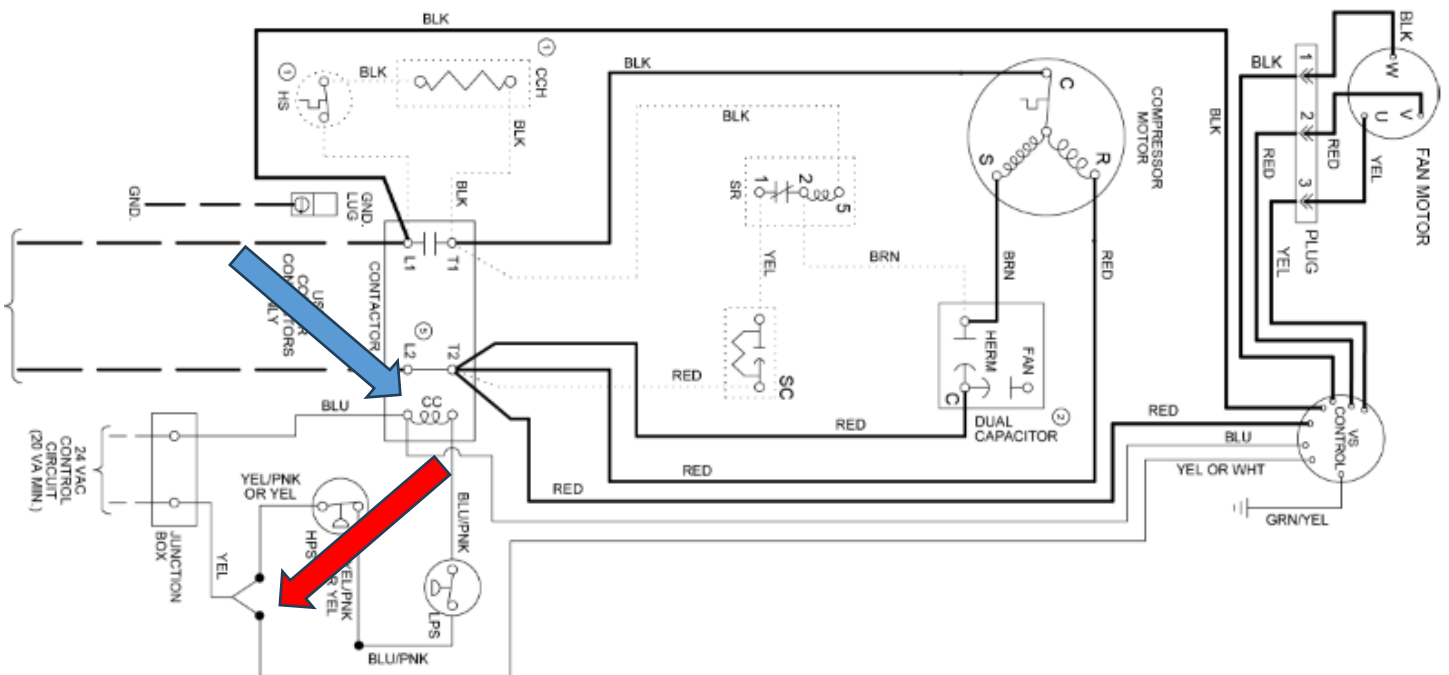

On non-premium heat pump models, the ECM motor controller 24V signal passes through the unit defrost control. The defrost control fan motor relay is normally closed. The fan motor relay only opens during a defrost cycle. When testing, control voltage needs to be tested going into the relay and coming out of the relay.

Make sure that the defrost control is not in a defrost cycle during testing. During a defrost cycle, the relay opens to shut the outdoor fan motor off and the defrost controls WOUT is energized to operate auxiliary heating to temper the indoor air. Test for 24V A/C at the locations shown below.

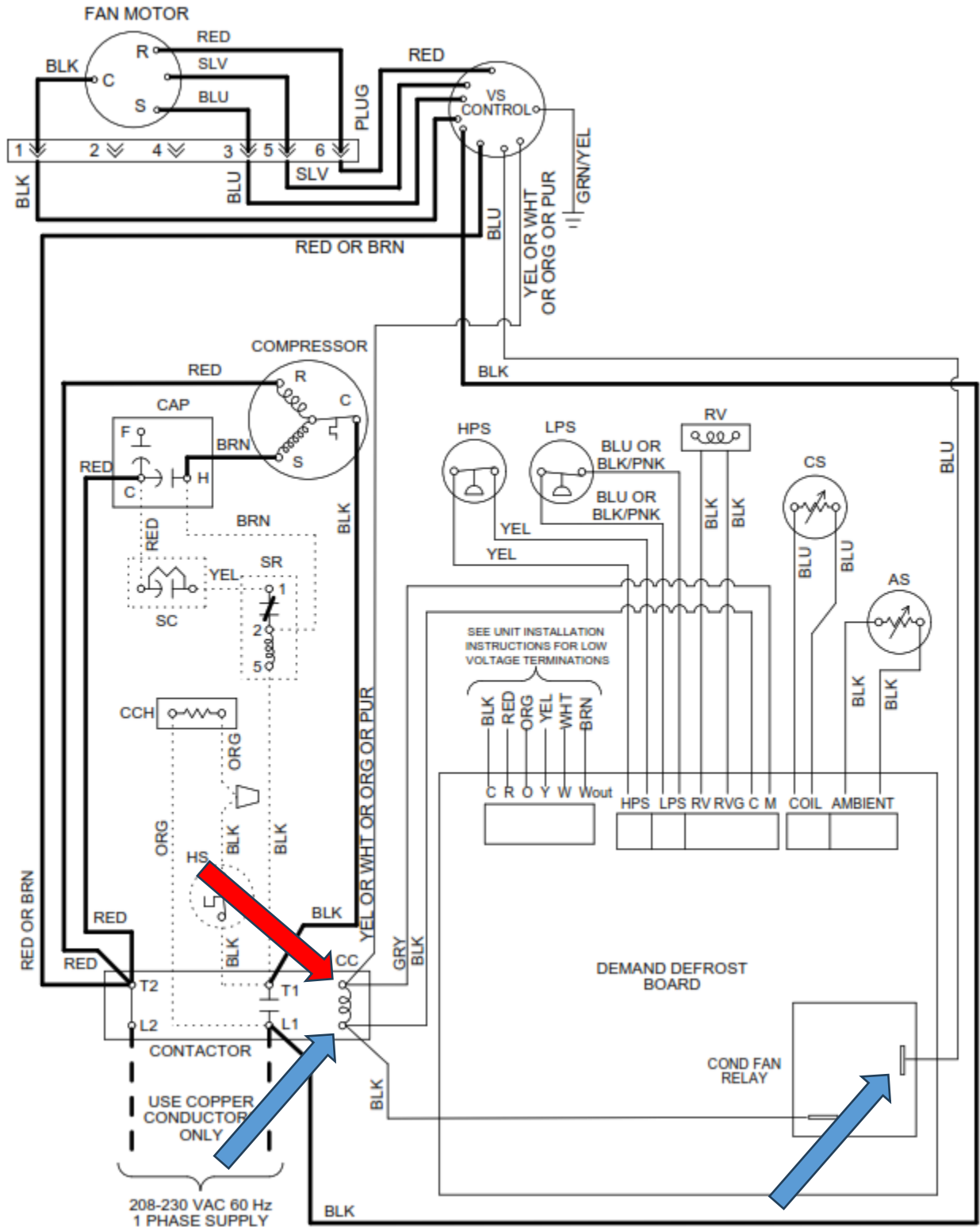

Most premium air conditioning and heat pump models utilize a variable speed outdoor ECM fan motor. The ECM motor controller is provided with a PWM (pulse width modulating) signal in lieu of 24V A/C. The PWM signal can be checked if a digital multimeter capable of reading such signal is available. Check the PWM signal at the locations shown below.

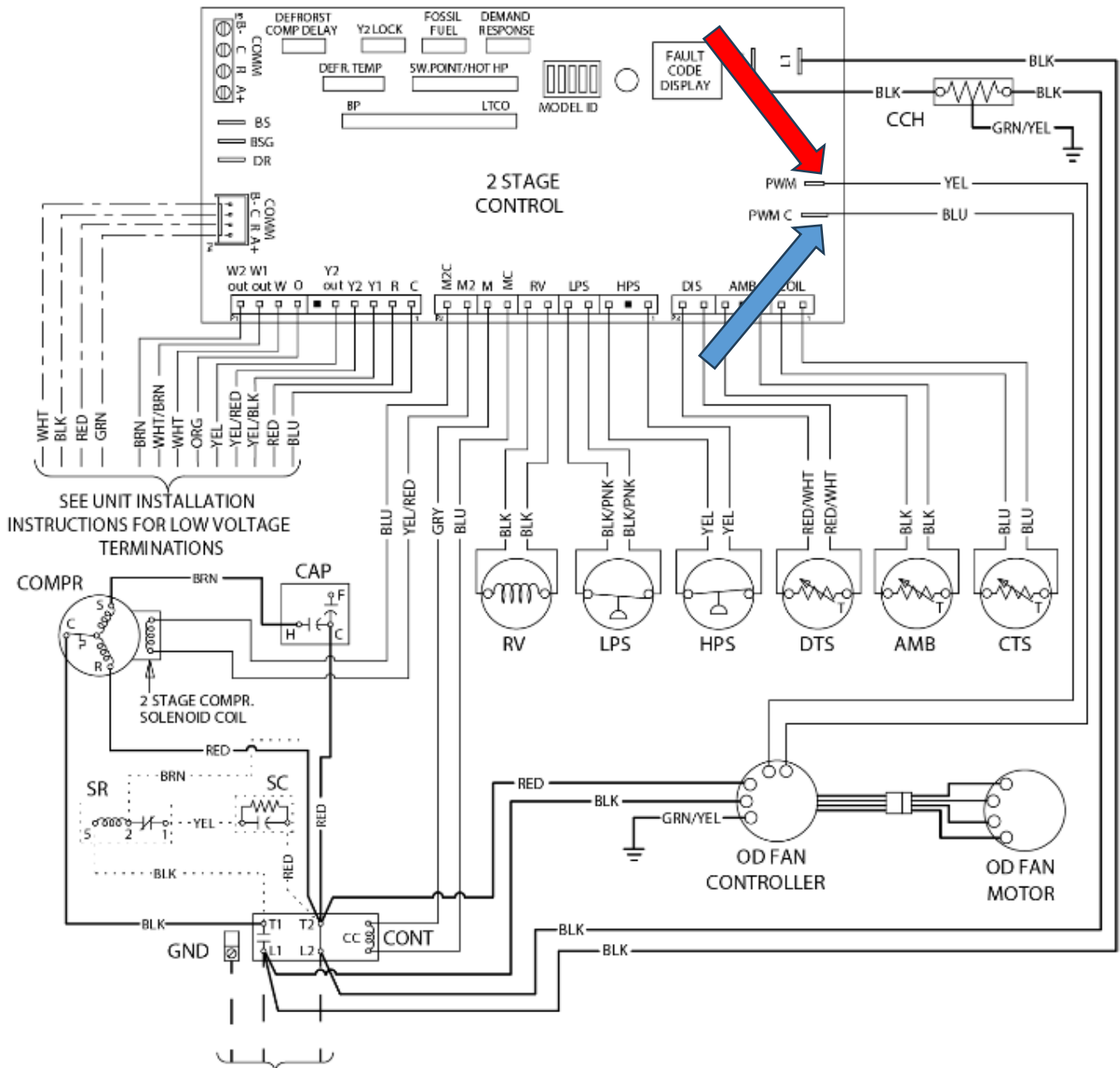

If a PWM capable digital multi-meter is not available, use the defrost control and its 7-segment display to visually see what the PWM signal being commanded is. With the air-conditioner or heat-pump operating in cooling or heat pump heating mode, simply press the defrost control push-button located next to the 7-segment display as shown to the right for < 2 seconds. The PWM signal will be shown on the 7-segment display. The PWM signal changes based on outdoor temperature as sensed by the outdoor unit ambient temperature sensor. The outdoor unit control installation manual (5462280-UAI-B-0724) contains data tables regarding the PWM signal depending on outdoor temperature and whether the unit is in first stage or second stage operation. Typical PWM signals can range from 05 to 64.

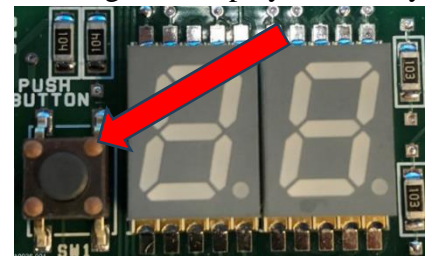

If the controller is tested as indicated above and both LINE and CONTROL signals are present, but the outdoor fan motor is not operating, the motor needs to be tested. Remove line voltage power from the outdoor unit and allow 2 minutes for the controller capacitors to discharge.

Physically inspect the fan motor wiring for insulation damage and connection to the controller. The outdoor fan motor has a 3-pin plug, and the controller has a 3-pin socket as shown to the right. Ensure that the connector is completely together, with tab locking it into place. Push each of the wires individually to ensure that they are fully seated into the plastic connectors. If a loose connection was found and corrected, re-apply power and test for motor operations. Understand that this ECM motor may take in some instances up to 20 seconds to start. Allow time for the motor to start. If further diagnostics are required, remove line power and again allow 2 minutes for the controller capacitors to discharge.



The outdoor fan motor windings need to be tested using an ohm meter. To perform a test, disconnect the plug / socket connection to check across the motor windings. The three motor wires are referred to as U (yellow) V (red) and W (black). The motor itself is three-phase, so windings theoretically should all read the same across each other. When taking ohm readings, we recommend inserting meter leads into the back side (wire side) of the connector as shown below.



This method ensures a better meter connection to the windings. It also protects the integrity of the plug / socket connections. If testing from the other side of the plug, most likely the meter leads will damage the size of the connectors. An ohm reading across U – V, V-W, and U – W should be between 12 – 14 ohms. If outside of this range, condemn the motor. If an ohm reading difference between any two of the windings is greater than 0.3 ohms, condemn the motor.

The motor must also be checked for internal damage by physically spinning the motor and fan blade by hand. It should spin freely (no drag) and come to a gradual stop. If excessive noise is heard during the test or motor comes to a more sudden stop after spinning, condemn the motor as most likely there is bearding damage.

Damage to the motor (failed motor) whether it is bearing related or winding / electrically related, it will not damage the controller. As with all ECM controllers, they protect themselves internally when a motor failure occurs. For example, if a motor has bearing damage, the controller will attempt to start the motor several times and then lock itself out to prevent damage. If a motor failure occurs, replace the motor only. If the motor tests described above indicate a good motor, replace the controller only.

If you have any questions regarding this, feel free to call Ducted Systems Technical Services at 1-877-UPG-SERV and speak with a technical support representative or contact your Regional Technical Service Manager.



Casey McConaughy
UPG Regional Technical Service Manager
Ducted Systems Technical Services - Johnson Controls