

WEST CENTER OAKS

2721 - 2759 S. 140th Street / Omaha, NE

4,264 SF for Lease / Excellent Tenant Mix



Richard Secor, Jr., CCIM / Partner / richard.secor@lundco.com / +1 402 548 4010

WE ARE
THE CENTER
OF RETAIL

LUNDCO.COM

Cushman & Wakefield Copyright 2020. No warranty or representation, express or implied, is made to the accuracy or completeness of the information contained herein, and same is submitted subject to errors, omissions, change of price, rental or other conditions, withdrawal without notice, and to any special listing conditions imposed by the property owner(s). As applicable, we make no representation as to the condition of the property (or properties) in question.





WEST CENTER OAKS

2721 - 2759 S. 140th Street / Omaha, NE

4,264 SF for Lease / Excellent Tenant Mix



Property Overview

Excellent tenant mix: Red Lobster, Bridal Traditions, Sherwin Williams, Trade Post, Push Pedal Pull, FedEx Office, Leslie's Pool Supplies, All Nails, Sport Clips and Rudolph's Run/Walk Shoes.

Property Highlights

Lease Rate	\$12.50 PSF NNN
Total Available	4,264 SF
Total Contiguous	4,264 SF
Building Size	44,746 SF
Year Built/Renovated	1985/1999 & 2001
Total Site Area	5.44 AC
Zoning	I-1
Clearance Height	13.25' - 15'
Traffic Counts	40,734 EADT (140 th & W. Center Road)
2021 Budgeted Operating Expenses	\$2.60 PSF Taxes \$0.31 PSF Insurance \$2.62 PSF CAM \$5.53 PSF TOTAL

Neighborhood Demographics

	 POPULATION	 MEDIAN HOUSEHOLD INCOME	 NUMBER OF HOUSEHOLDS
1 Mile	9,467	\$72,850	3,937
3 Miles	90,650	\$80,935	35,502
5 Miles	249,002	\$91,390	98,822

Availability

Suite	Square Feet (min - max)	Price/SF NNN	Date Available
2727	4,264 - 4,264	\$12.50	Immediately

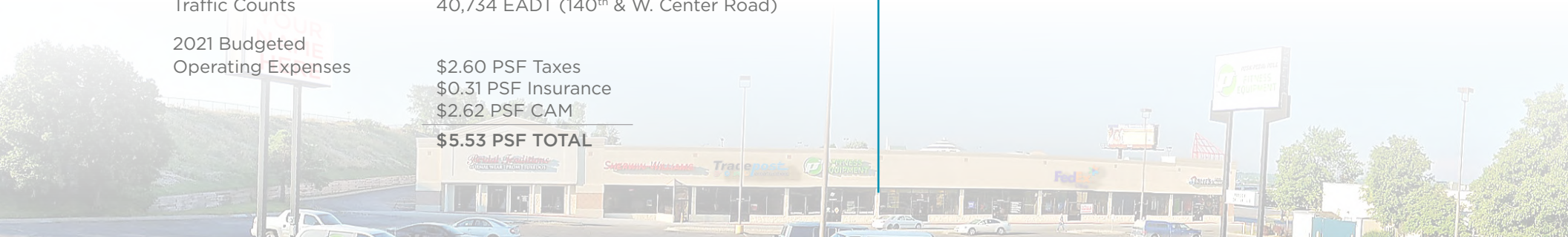

Richard Secor, Jr., CCIM / Partner / richard.secor@lundco.com / +1 402 548 4010

Cushman & Wakefield Copyright 2020. No warranty or representation, express or implied, is made to the accuracy or completeness of the information contained herein, and same is submitted subject to errors, omissions, change of price, rental or other conditions, withdrawal without notice, and to any special listing conditions imposed by the property owner(s). As applicable, we make no representation as to the condition of the property (or properties) in question.

4,264 SF for Lease / Excellent Tenant Mix





WEST CENTER OAKS

2721 - 2759 S. 140th Street / Omaha, NE

4,264 SF for Lease / Excellent Tenant Mix

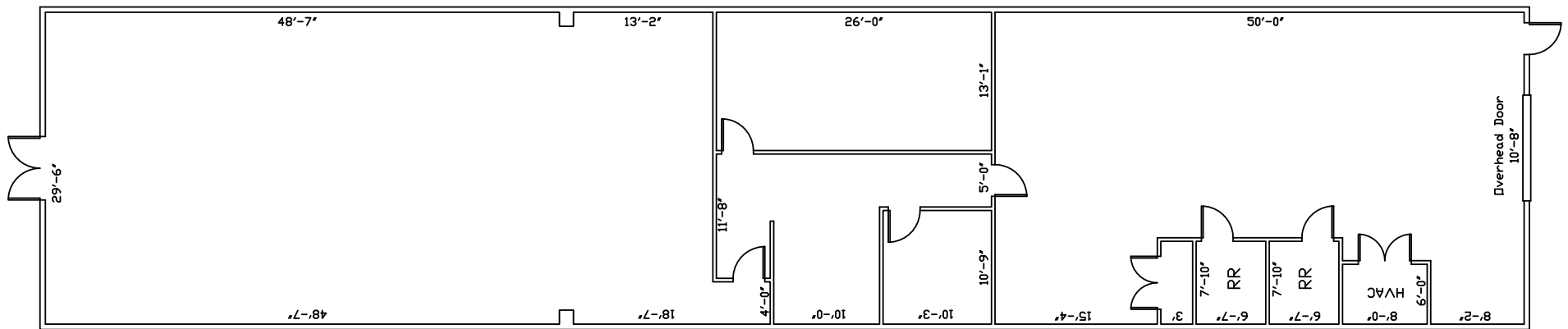

Richard Secor, Jr., CCIM / Partner / richard.secor@lundco.com / +1 402 548 4010

Cushman & Wakefield Copyright 2020. No warranty or representation, express or implied, is made to the accuracy or completeness of the information contained herein, and same is submitted subject to errors, omissions, change of price, rental or other conditions, withdrawal without notice, and to any special listing conditions imposed by the property owner(s). As applicable, we make no representation as to the condition of the property (or properties) in question.

4,264 SF for Lease / Excellent Tenant Mix

Available Signage Capability

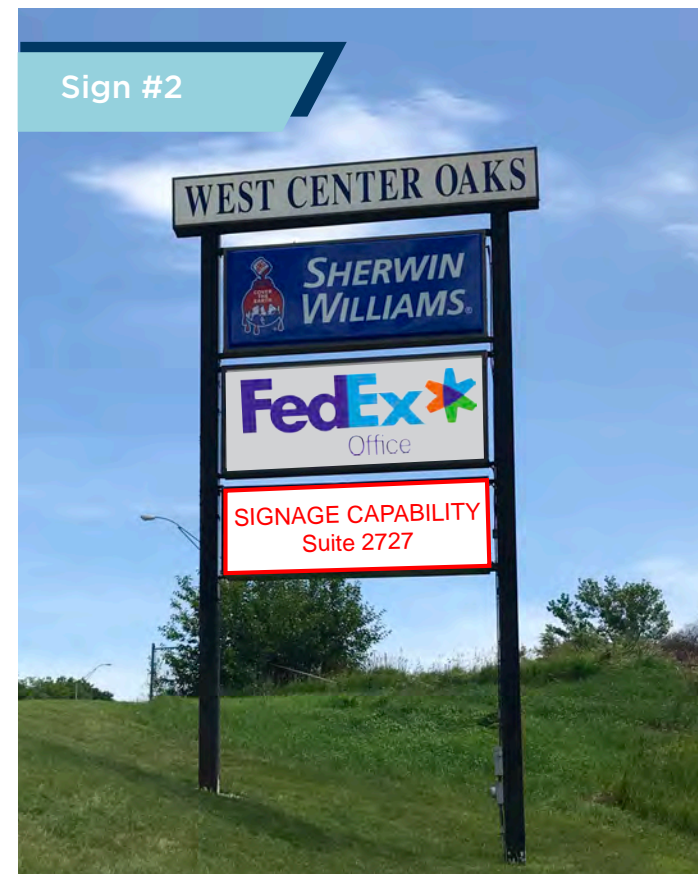

4,264 SF for Lease / Excellent Tenant Mix

