



1916 Sanford Street & 1901 Peck Street
Muskegon, Michigan 49441

Property Overview

Two industrial buildings consisting of 37,466 SF total on 1.45 acres.

Buildings may be sold separately

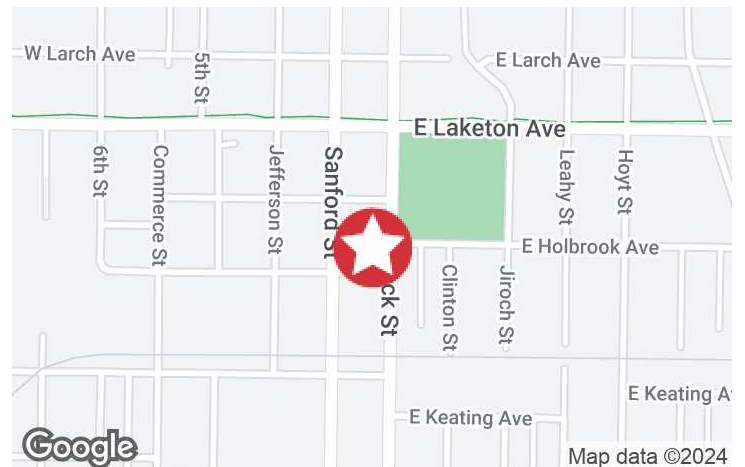

For More Information

Noah Rachor

O: 616 242 1126

noahr@naiwwm.com

Chris Prins, SIOR

O: 616 242 1107

chrisp@naiwwm.com

Sale Overview

1916 Sanford and 1901 Peck
Muskegon, Michigan 49441

Sale Information

Price:	\$300,000.00
Per SF:	\$8.01
Municipality:	City of Muskegon
PPN:	61-24-232-002-0008-00 and 61-24-232-002-0004-00
SEV (2023) Both parcels:	\$290,200.00
Taxable Value (2023) Both parcels:	\$227,728.00
Summer Taxes (2022) Both parcels:	\$2,543.13
Winter Taxes (2022) Both parcels:	\$11,031.35
Total Taxes (2022) Both parcels:	\$13,574.48

Legal Description

1901 Peck Street 61-24-232-002-0004-00

PROPERTY EXEMPT FROM AD VALOREM TAXES AND ASSESSED ON THE SPECIAL ACT ROLL PURSUANT TO PA 261 OF 2003 EXPIRING 12/30/2023. CITY OF MUSKEGON DENNIS SMITH & COS SOUTH SIDE ADDITION S 20 FT OF LOT 3 & LOTS 4 TO 7 INCL BLK 2 ALSO E 1/2 OF VAC ALLEY ADJ TO SAID PROP

1916 Sanford Street 61-24-232-002-0008-00

PROPERTY EXEMPT FROM AD VALOREM TAXES AND ASSESSED ON THE SPECIAL ACT ROLL PURSUANT TO PA 261 OF 2003 EXPIRING 12/30/2023. CITY OF MUSKEGON DENNIS SMITH & COS SOUTH SIDE ADDITION LOTS 8 TO 12 INCL BLK 2 ALSO W 1/2 OF VAC ALLEY ADJ TO SAID LOTS

Property Overview

1916 Sanford and 1901 Peck
Muskegon, Michigan 49441



1916 Sanford Street



1901 Peck Street

Property Information

Location:	Muskegon, MI
Total Building SF:	37,466 SF
1916 Sanford Street SF:	18,880 SF
1901 Peck Street SF:	18,586 SF
Year Built:	1950
Acreage:	1.45 Acres
Signage:	Building
Parking:	Ample
Zoning:	B4

Utilities

Electric:	Consumers Energy
Telephone:	Choice
Natural Gas:	DTE
Sanitary Sewer:	-
Storm Sewer:	-
Water:	-

Building Layouts

1916 Sanford and 1901 Peck
Muskegon, Michigan 49441

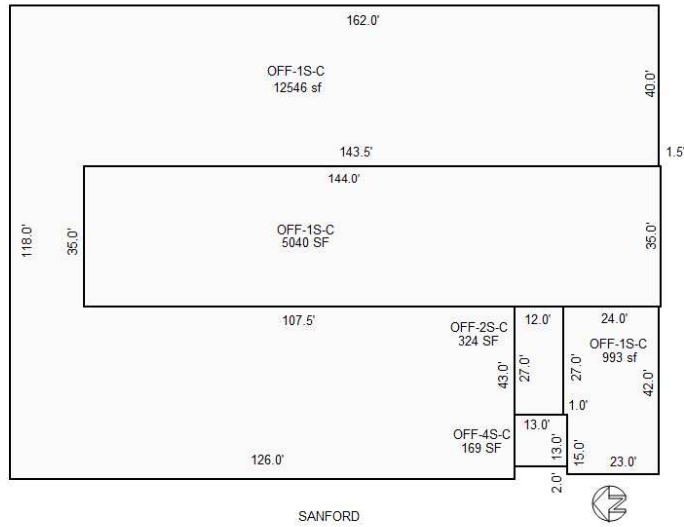

1916 Sanford Street

Sketch by Apex Sketch

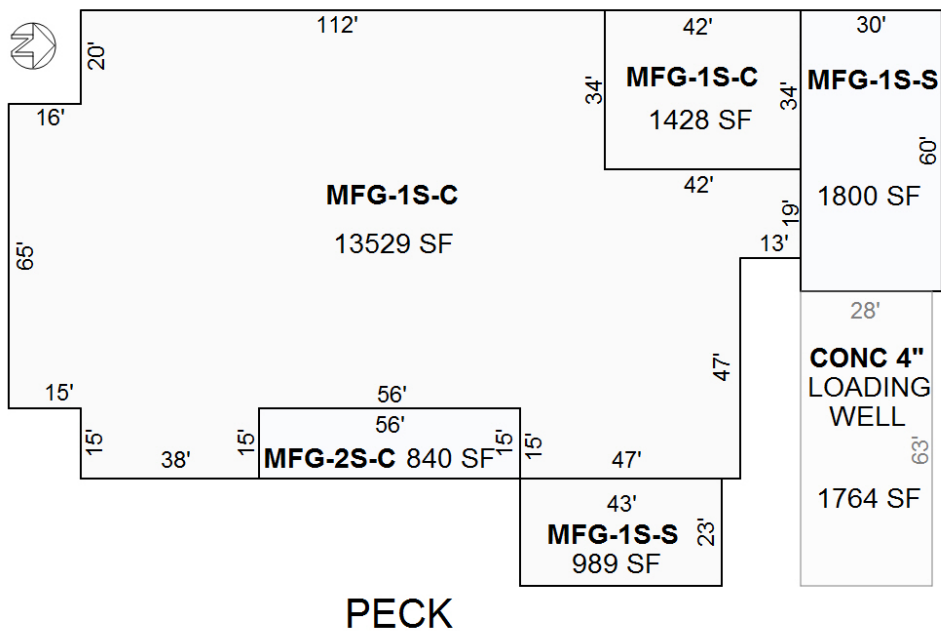

1901 Peck Street

Sketch by Apex Sketch

1916 Sanford Street Floor Plan

1916 Sanford and 1901 Peck
Muskegon, Michigan 49441

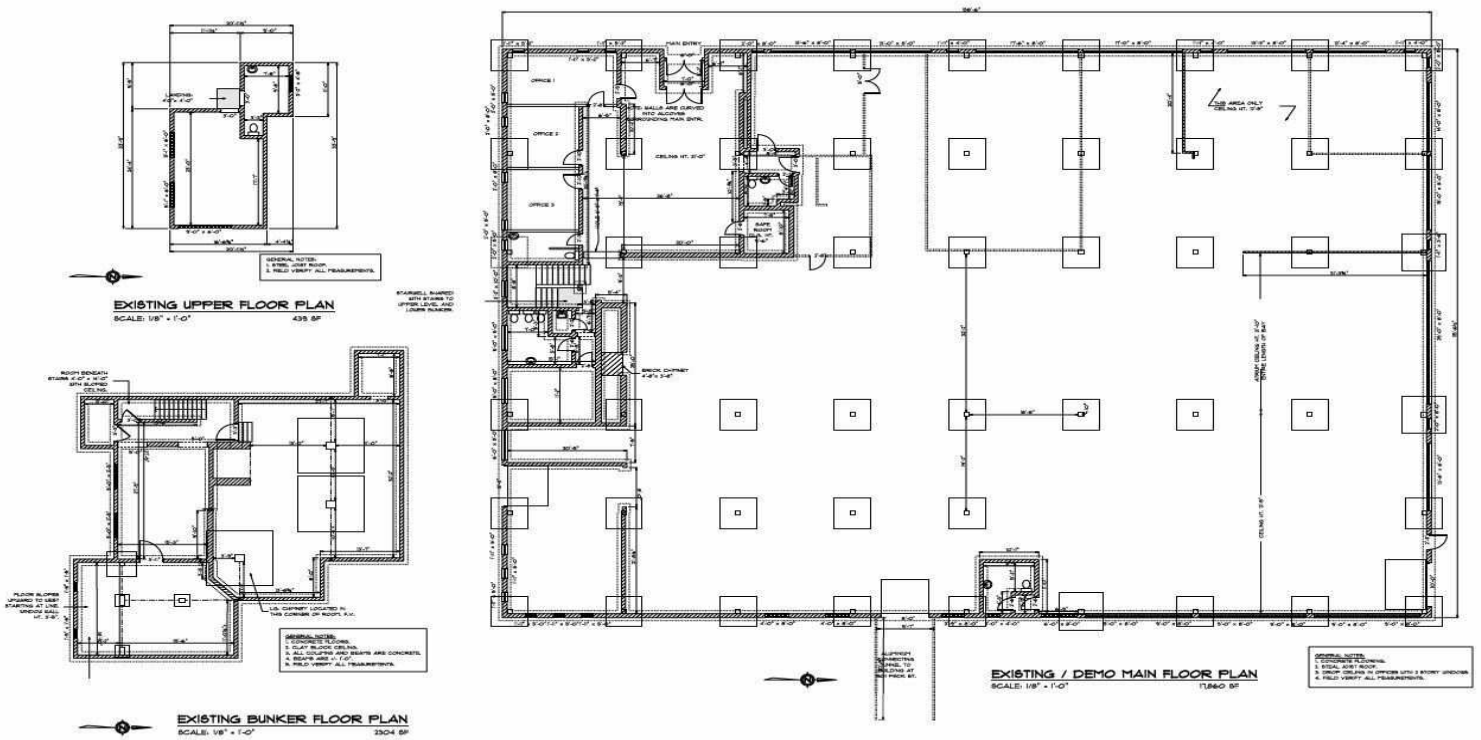

LATEST PLOT DATE:

REVISIONS	MARK W HACKER ARCHITECTURAL & CONSTRUCTION SERVICES, LLC 1000 CEDAR STREET, MUSKEGON, MI 49441 PHONE: 616-272-1100	DESIGNED BY TJ LEE CHECKED BY TJ LEE	PROJECT 1916 SANFORD ST. MUSKEGON, MI 49441	COMPILED BY JAY CARPINE 1916 SANFORD ST. MUSKEGON, MI 49441	DATE 08/20/2018	PROJECT NUMBER DI
MAIN, UPPER AND BUNKER EXISTING AND DEMOLITION PLANS						

1901 Peck Street Floor Plan

1916 Sanford and 1901 Peck
Muskegon, Michigan 49441

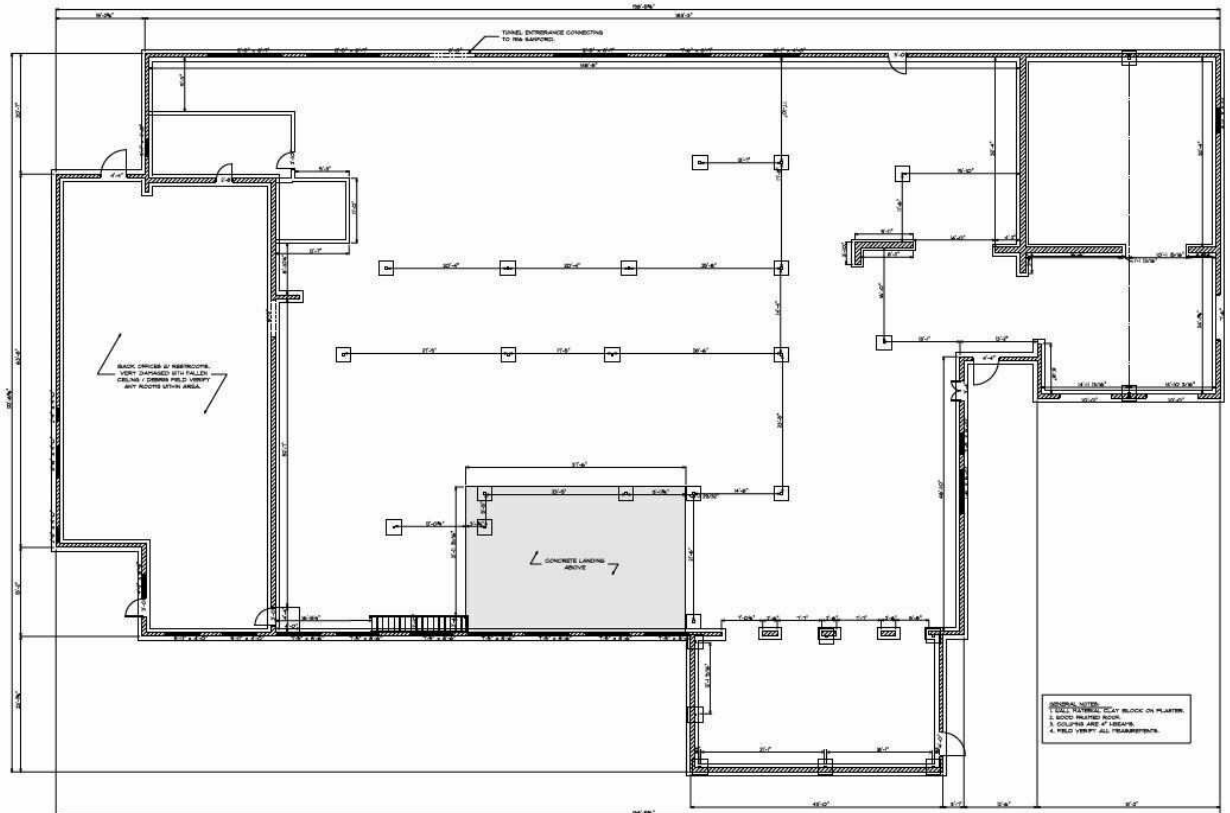

EXISTING / DEMO FLOOR PLAN
SCALE: 1/8" = 1'-0"
1/18/20 SF



EXISTING MEZZANINE FLOOR PLAN
SCALE: 1/8" = 1'-0"
889 SF

GENERAL NOTES:
1. EXISTING FLOORING TO REMAIN.
2. REMOVE ALL EXISTING PARTITIONS.
3. VERIFY ALL DIMENSIONS.
4. FIELD VERIFY ALL DIMENSIONS.



LATEST PLOT DATE:

REVISION DATE:

MARK W HACKER
ARCHITECTURAL & CONSTRUCTION
SERVICES, LLC
1916 SANFORD STREET, MUSKEGON, MI 49441
PHONE: 616.776.0100

DESIGNER:
MARK W HACKER
CHECKED BY:
MATT WILSON
DATE: 01/18/20

1901 PECK ST. MUSKEGON, MI 49441
**EXISTING AND DEMOLITION MAIN
AND MEZZANINE FLOOR PLANS**

COMPUTER FILE NAME:
20190118.DWG
SHEET NUMBER:
DI

1916 Sanford Street Photos

1916 Sanford and 1901 Peck
Muskegon, Michigan 49441

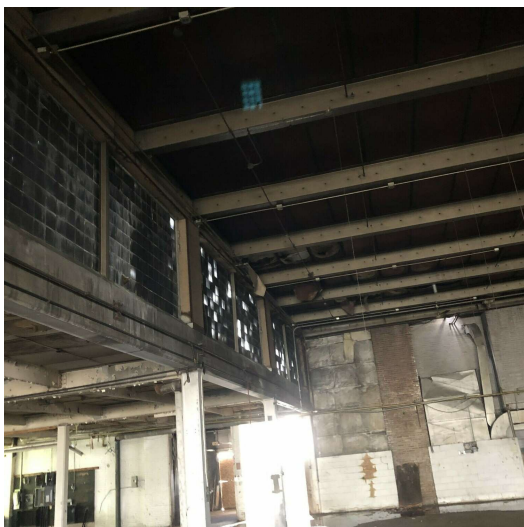

1916 Sanford Street Building Overview

1916 Sanford and 1901 Peck
Muskegon, Michigan 49441

Mfg/Warehouse Information

Mfg/Whse SF:	-
Floors:	-
Air Conditioning:	-
HVAC:	-
Ceiling Height:	18'
Sprinklered:	-
Lighting:	-
Electric Service:	-
Column Spacing:	-
Grade Level Doors:	1
Loading Docks:	2
Rail Siding:	N/A
Floor Drains:	-
Compressed Air:	-
Cranes:	-
Elevators:	-
Shop Office:	-
Shop Lunch Room:	-
Shop Restroom:	-

Office Information

Office SF:	-SF
Floors:	-
HVAC:	-
Air Conditioning:	-
Sprinklered:	-
Ceiling Height:	-'
Lighting:	-
Communication Equipment:	-
Private Offices:	-
Conference Room:	-
Lunch Room:	-
Restrooms:	-
Kitchen/Break Room:	-
Elevators:	-



1901 Peck Street Photos

1916 Sanford and 1901 Peck
Muskegon, Michigan 49441

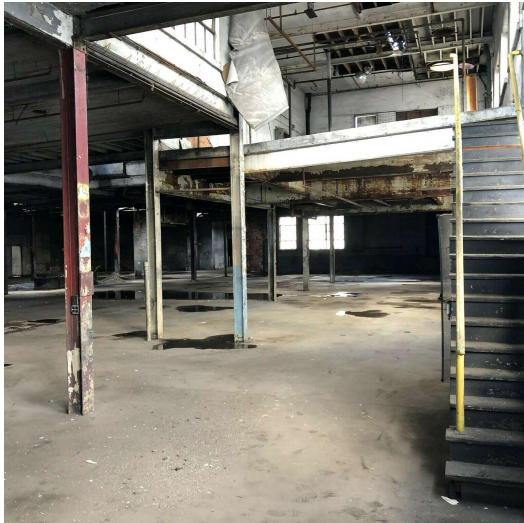
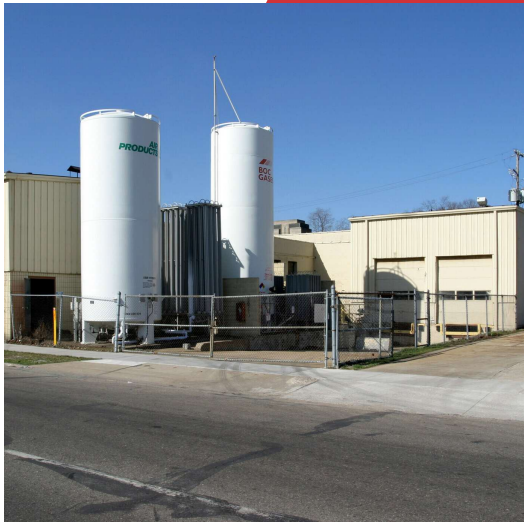
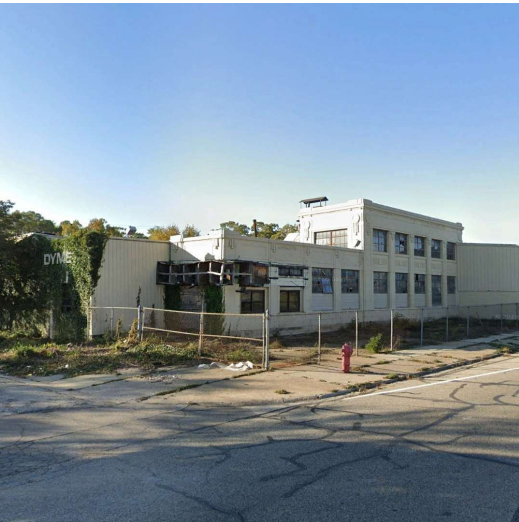

1901 Peck Street Building Overview

1916 Sanford and 1901 Peck
Muskegon, Michigan 49441

Mfg/Warehouse Information

Mfg/Whse SF:	-
Floors:	-
Air Conditioning:	-
HVAC:	-
Ceiling Height:	18
Sprinklered:	-
Lighting:	-
Electric Service:	-
Column Spacing:	-
Grade Level Doors:	0
Loading Docks:	2
Rail Siding:	N/A
Floor Drains:	-
Compressed Air:	-
Cranes:	-
Elevators:	-
Shop Office:	-
Shop Lunch Room:	-
Shop Restroom:	-

Office Information

Office SF:	-SF
Floors:	-
HVAC:	-
Air Conditioning:	-
Sprinklered:	-
Ceiling Height:	-'
Lighting:	-
Communication Equipment:	-
Private Offices:	-
Conference Room:	-
Lunch Room:	-
Restrooms:	-
Kitchen/Break Room:	-
Elevators:	-



Demographics Map & Report

1916 Sanford and 1901 Peck
Muskegon, Michigan 49441

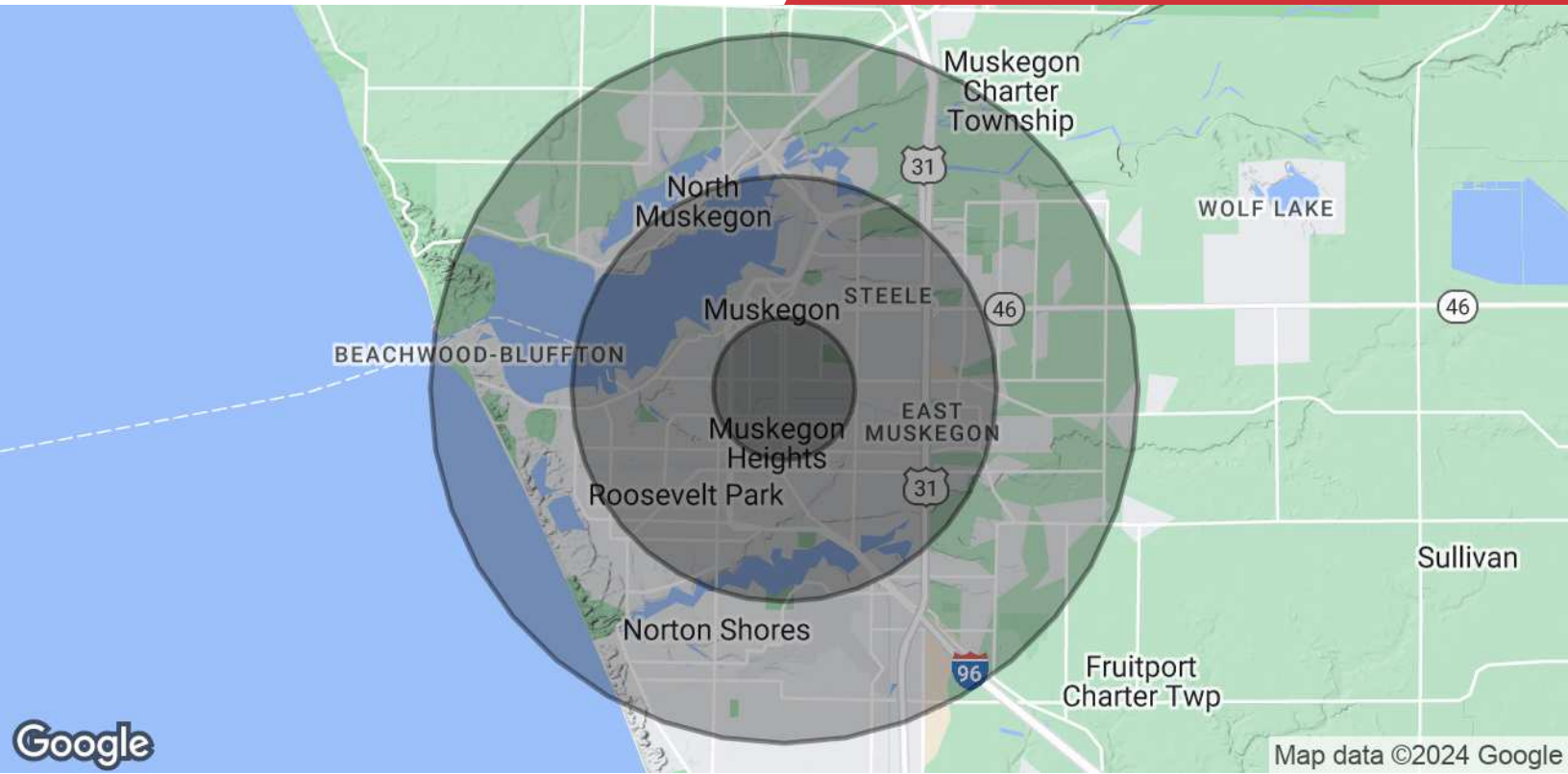

POPULATION	1 MILE	3 MILES	5 MILES
Total Population	12,265	62,518	101,781
Average Age	33.3	35.5	38.5
Average Age (Male)	33.3	33.2	36.7
Average Age (Female)	33.0	37.5	40.6
HOUSEHOLDS & INCOME	1 MILE	3 MILES	5 MILES
Total Households	5,324	27,219	43,822
# of Persons per HH	2.3	2.3	2.3
Average HH Income	\$33,799	\$44,270	\$54,854
Average House Value	\$50,752	\$83,804	\$109,602

* Demographic data derived from 2020 ACS - US Census

Location Map

1916 Sanford and 1901 Peck
Muskegon, Michigan 49441

