

LAND  
FOR LEASE

# +/- 1.474 ACRES OF LAND ON FM 1485 FOR LEASE OR BUILD-TO-SUIT

18546 FM 1485, NEW CANEY, TX 77357



## OFFERING SUMMARY

|            |                  |
|------------|------------------|
| Price:     | Call For Pricing |
| Lot Size:  | 1.474 Acres      |
| Market:    | Northeast        |
| Submarket: | New Caney        |
| County:    | Montgomery       |

## PROPERTY HIGHLIGHTS

- Approximately 1.474 acres available for ground lease or build-to-suit opportunity on FM 1485, in front of brand-new self-storage facility
- Located less than 3 miles west of US-69, in close proximity to Lowe's and Wal-Mart distribution centers, Valley Ranch Town Center, Big Rivers Waterpark, Speedsportz Racing Park, Randall Reed Stadium, and multiple new residential developments
- Approximately 200 ft of frontage on FM 1485
- Rapidly developing area, with average traffic of over 23,000 vehicles per day on FM 1485
- Excellent development potential
- Property located partially in 500 year flood plain, per FEMA maps
- Full demographic package available

### FOR MORE INFORMATION, PLEASE CONTACT:

**JOEL C. ENGLISH**  
PRESIDENT/PRINCIPAL  
713.473.7200  
JOEL@TEXASCRES.COM

**W. DOUGLASS LARSON**  
EXECUTIVE VICE PRESIDENT/PRINCIPAL  
713.824.3799  
DOUG@TEXASCRES.COM

**CHRIS JOYCE**  
VICE PRESIDENT BROKERAGE  
936.577.0836  
CHRIS@TEXASCRES.COM

LAND  
FOR LEASE

# +/- 1.474 ACRES OF LAND ON FM 1485 FOR LEASE OR BUILD-TO-SUIT

18546 FM 1485, NEW CANEY, TX 77357

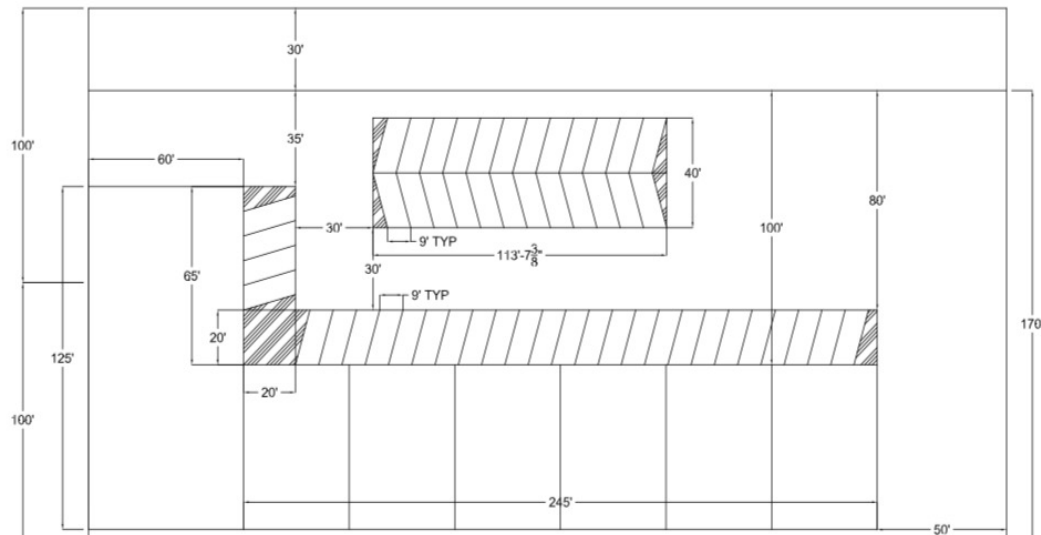
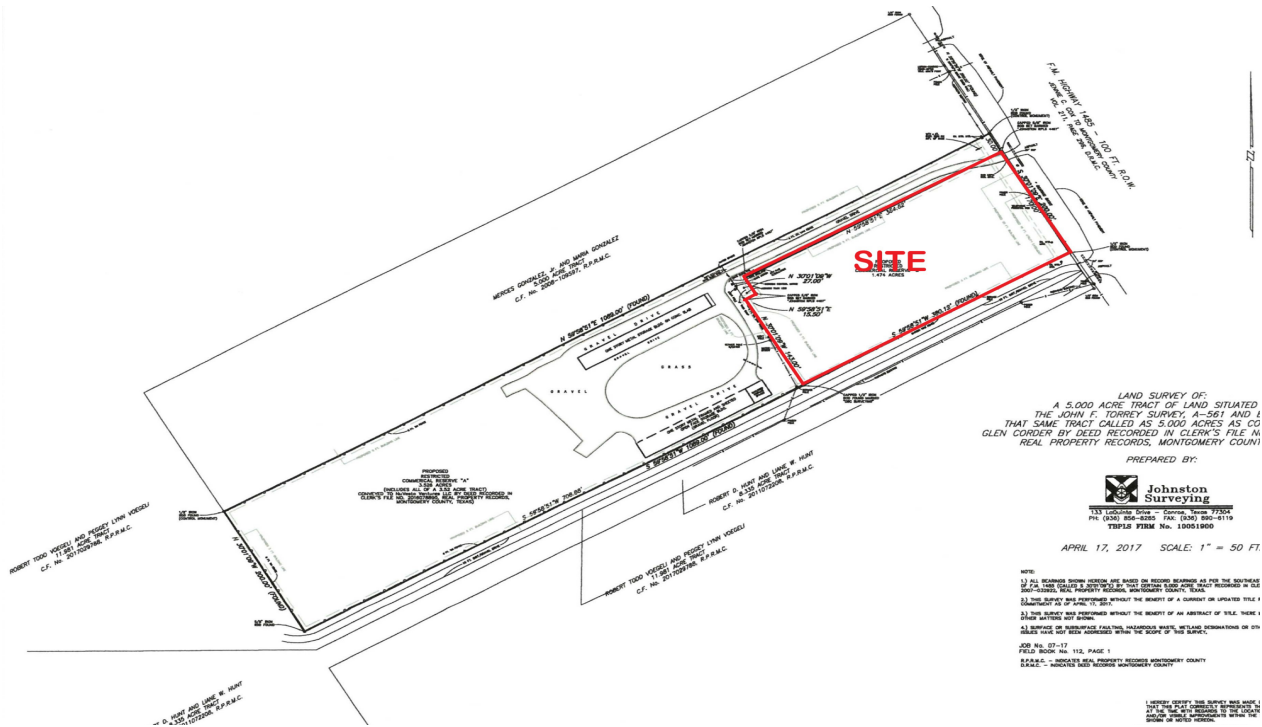

FOR MORE INFORMATION, PLEASE CONTACT:

**JOEL C. ENGLISH**  
PRESIDENT/PRINCIPAL  
713.473.7200  
JOEL@TEXASCRES.COM

**W. DOUGLASS LARSON**  
EXECUTIVE VICE PRESIDENT/PRINCIPAL  
713.824.3799  
DOUG@TEXASCRES.COM

**CHRIS JOYCE**  
VICE PRESIDENT BROKERAGE  
936.577.0836  
CHRIS@TEXASCRES.COM

LAND  
FOR LEASE

# +/- 1.474 ACRES OF LAND ON FM 1485 FOR LEASE OR BUILD-TO-SUIT

18546 FM 1485, NEW CANEY, TX 77357

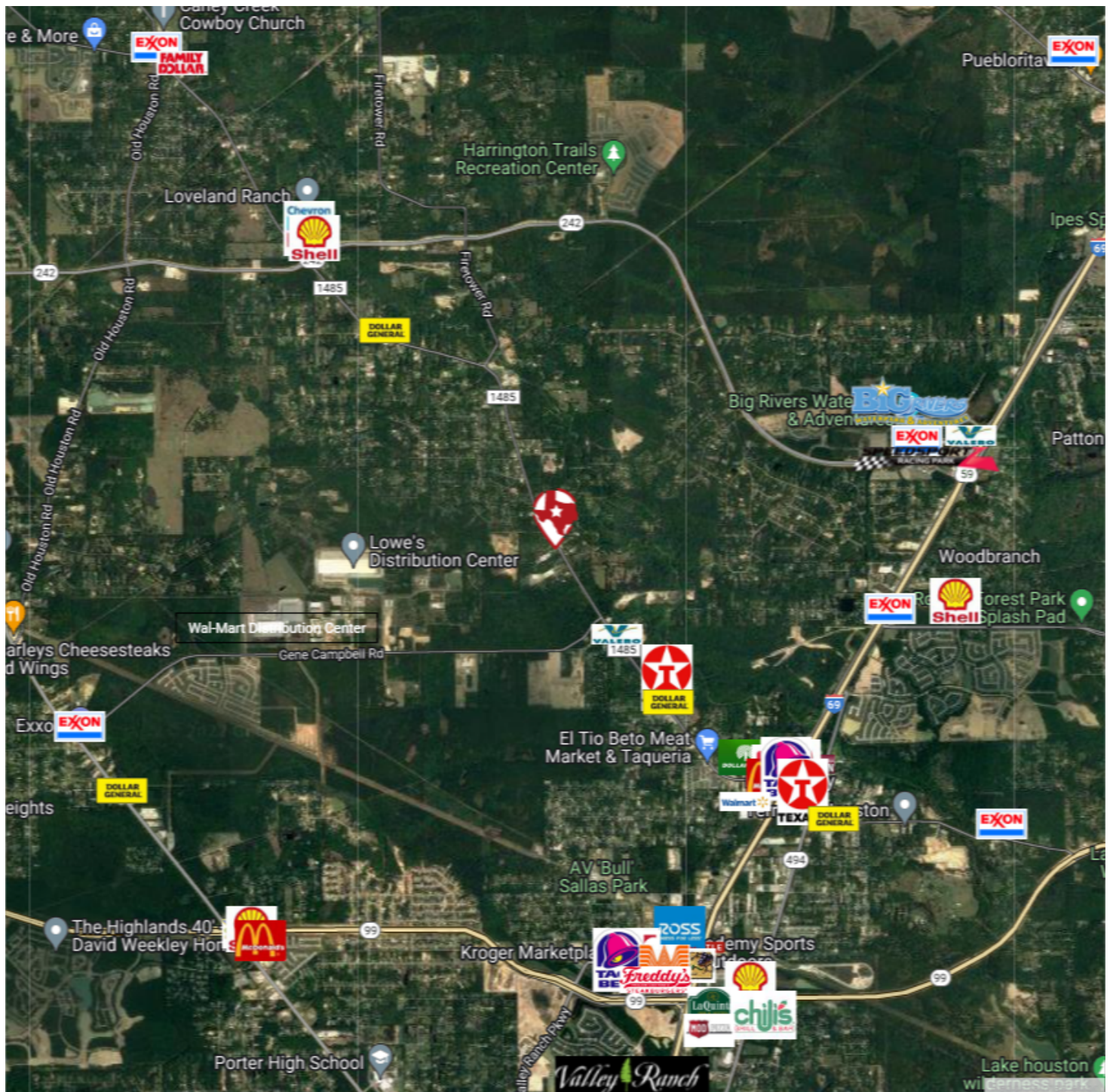

FOR MORE INFORMATION, PLEASE CONTACT:

**JOEL C. ENGLISH**  
PRESIDENT/PRINCIPAL  
713.473.7200  
JOEL@TEXASCRES.COM

**W. DOUGLASS LARSON**  
EXECUTIVE VICE PRESIDENT/PRINCIPAL  
713.824.3799  
DOUG@TEXASCRES.COM

**CHRIS JOYCE**  
VICE PRESIDENT BROKERAGE  
936.577.0836  
CHRIS@TEXASCRES.COM

LAND  
FOR LEASE

**+/- 1.474 ACRES OF LAND ON FM 1485  
FOR LEASE OR BUILD-TO-SUIT**

18546 FM 1485, NEW CANEY, TX 77357

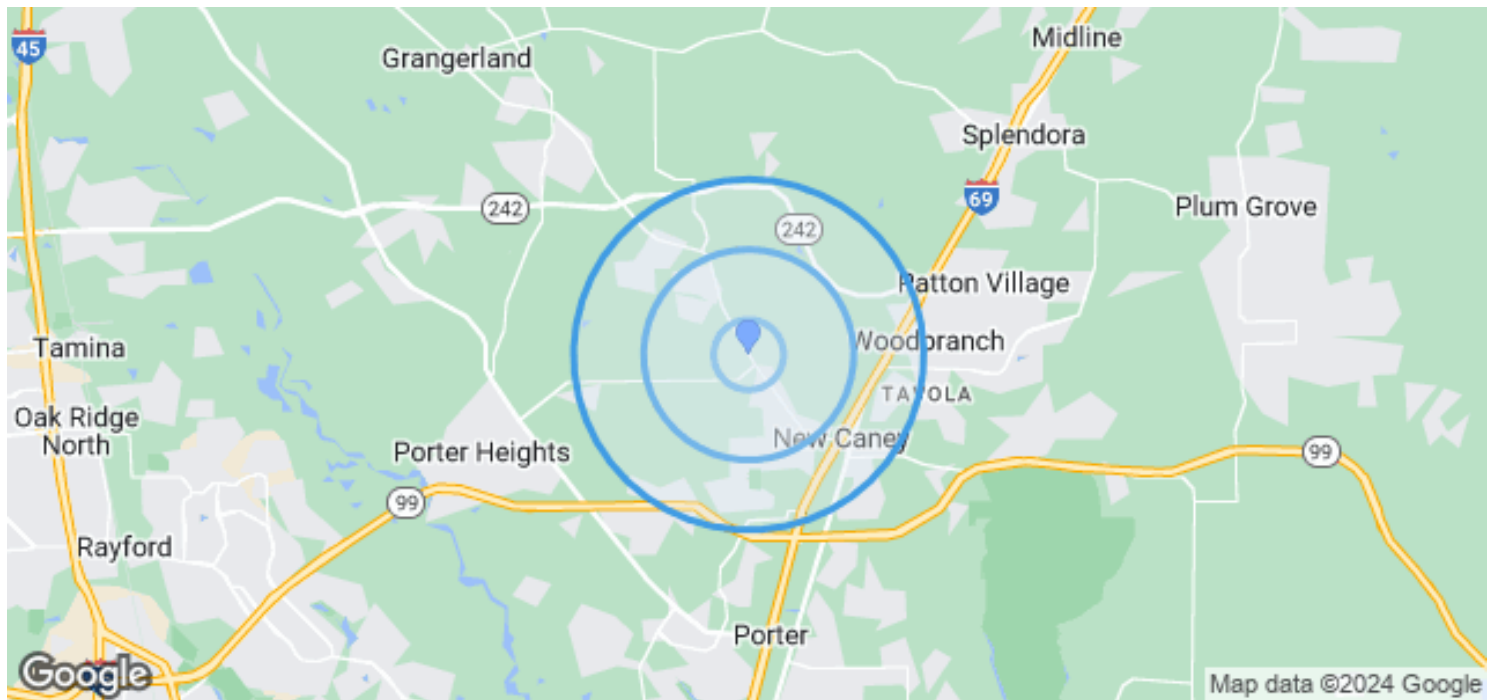

| <b>POPULATION</b>              | <b>1 MILE</b> | <b>3 MILE</b> | <b>5 MILE</b> |
|--------------------------------|---------------|---------------|---------------|
| Total Population               | 3,684         | 14,411        | 46,166        |
| Median age                     | 39.8          | 35.7          | 36.0          |
| Median age (Male)              | 40.2          | 35.1          | 35.4          |
| Median age (Female)            | 39.4          | 36.2          | 36.6          |
| <b>HOUSEHOLDS &amp; INCOME</b> | <b>1 MILE</b> | <b>3 MILE</b> | <b>5 MILE</b> |
| Total households               | 1,284         | 4,728         | 15,291        |
| # of persons per HH            | 2.87          | 3.05          | 3.00          |
| Average HH income              | \$93,925      | \$72,035      | \$81,777      |
| Average house value            | \$188,605     | \$105,675     | \$113,882     |

\*Demographic data valid as of January 2020 and is derived from US Census and other official government sources

FOR MORE INFORMATION, PLEASE CONTACT:

**JOEL C. ENGLISH**  
PRESIDENT/PRINCIPAL  
713.473.7200  
JOEL@TEXASCRES.COM

**W. DOUGLASS LARSON**  
EXECUTIVE VICE PRESIDENT/PRINCIPAL  
713.824.3799  
DOUG@TEXASCRES.COM

**CHRIS JOYCE**  
VICE PRESIDENT BROKERAGE  
936.577.0836  
CHRIS@TEXASCRES.COM



LAND  
FOR LEASE

# +/- 1.474 ACRES OF LAND ON FM 1485 FOR LEASE OR BUILD-TO-SUIT

18546 FM 1485, NEW CANEY, TX 77357



## Information About Brokerage Services

Texas law requires all real estate license holders to give the following information about brokerage services to prospective buyers, tenants, sellers and landlords.

11-2-2015



### TYPES OF REAL ESTATE LICENSE HOLDERS:

- **A BROKER** is responsible for all brokerage activities, including acts performed by sales agents sponsored by the broker.
- **A SALES AGENT** must be sponsored by a broker and works with clients on behalf of the broker.

### A BROKER'S MINIMUM DUTIES REQUIRED BY LAW (A client is the person or party that the broker represents):

- Put the interests of the client above all others, including the broker's own interests;
- Inform the client of any material information about the property or transaction received by the broker;
- Answer the client's questions and present any offer to or counter-offer from the client; and
- Treat all parties to a real estate transaction honestly and fairly.

### A LICENSE HOLDER CAN REPRESENT A PARTY IN A REAL ESTATE TRANSACTION:

**AS AGENT FOR OWNER (SELLER/LANDLORD):** The broker becomes the property owner's agent through an agreement with the owner, usually in a written listing to sell or property management agreement. An owner's agent must perform the broker's minimum duties above and must inform the owner of any material information about the property or transaction known by the agent, including information disclosed to the agent or subagent by the buyer or buyer's agent.

**AS AGENT FOR BUYER/TENANT:** The broker becomes the buyer/tenant's agent by agreeing to represent the buyer, usually through a written representation agreement. A buyer's agent must perform the broker's minimum duties above and must inform the buyer of any material information about the property or transaction known by the agent, including information disclosed to the agent by the seller or seller's agent.

**AS AGENT FOR BOTH - INTERMEDIARY:** To act as an intermediary between the parties the broker must first obtain the written agreement of *each party* to the transaction. The written agreement must state who will pay the broker and, in conspicuous bold or underlined print, set forth the broker's obligations as an intermediary. A broker who acts as an intermediary:

- Must treat all parties to the transaction impartially and fairly;
- May, with the parties' written consent, appoint a different license holder associated with the broker to each party (owner and buyer) to communicate with, provide opinions and advice to, and carry out the instructions of each party to the transaction.
- Must not, unless specifically authorized in writing to do so by the party, disclose:
  - o that the owner will accept a price less than the written asking price;
  - o that the buyer/tenant will pay a price greater than the price submitted in a written offer; and
  - o any confidential information or any other information that a party specifically instructs the broker in writing not to disclose, unless required to do so by law.

**AS SUBAGENT:** A license holder acts as a subagent when aiding a buyer in a transaction without an agreement to represent the buyer. A subagent can assist the buyer but does not represent the buyer and must place the interests of the owner first.

### TO AVOID DISPUTES, ALL AGREEMENTS BETWEEN YOU AND A BROKER SHOULD BE IN WRITING AND CLEARLY ESTABLISH:

- The broker's duties and responsibilities to you, and your obligations under the representation agreement.
- Who will pay the broker for services provided to you, when payment will be made and how the payment will be calculated.

**LICENSE HOLDER CONTACT INFORMATION:** This notice is being provided for information purposes. It does not create an obligation for you to use the broker's services. Please acknowledge receipt of this notice below and retain a copy for your records.

|  |             |                    |                |
|--|-------------|--------------------|----------------|
| Texas CRES, LLC  | 9004590     |                    | (713) 473-7200 |
| Licensed Broker /Broker Firm Name or Primary Assumed Business Name | License No. | Email              | Phone          |
| Joel C. English  | 465800      | joel@texascres.com |                |
| Designated Broker of Firm  | License No. | Email              | Phone          |
| Joel C. English  |             |                    |                |
| Licensed Supervisor of Sales Agent/ Associate                      | License No. | Email              | Phone          |
|  |             |                    |                |
| Sales Agent/Associate's Name                                       | License No. | Email              | Phone          |
|  |             |                    |                |

Buyer/Tenant/Seller/Landlord Initials

Date

Regulated by the Texas Real Estate Commission

Information available at [www.trec.texas.gov](http://www.trec.texas.gov)

IABS 1-0

### FOR MORE INFORMATION, PLEASE CONTACT:

**JOEL C. ENGLISH**  
PRESIDENT/PRINCIPAL  
713.473.7200  
JOEL@TEXASCRES.COM

**W. DOUGLASS LARSON**  
EXECUTIVE VICE PRESIDENT/PRINCIPAL  
713.824.3799  
DOUG@TEXASCRES.COM

**CHRIS JOYCE**  
VICE PRESIDENT BROKERAGE  
936.577.0836  
CHRIS@TEXASCRES.COM



LAND  
FOR LEASE

## **+/- 1.474 ACRES OF LAND ON FM 1485 FOR LEASE OR BUILD-TO-SUIT**

**18546 FM 1485, NEW CANEY, TX 77357**

Information contained in this marketing piece is furnished by property owners and brokers who acquire the information from third party websites, county appraisal districts appraisers, tax services, and inspectors. The information is shared with Texas CRES, LLC for reference and for marketing purposes. Texas CRES, LLC makes no representations to the validity or accuracy of the information. Neither the listing Broker, or the property owner make any warranty, guarantee, or representation to the accuracy of the information. You should rely exclusively on your own property research and studies to confirm the accuracy of any information contained herein.

**FOR MORE INFORMATION, PLEASE CONTACT:**

**JOEL C. ENGLISH**  
PRESIDENT/PRINCIPAL  
713.473.7200  
JOEL@TEXASCRES.COM

**W. DOUGLASS LARSON**  
EXECUTIVE VICE PRESIDENT/PRINCIPAL  
713.824.3799  
DOUG@TEXASCRES.COM

**CHRIS JOYCE**  
VICE PRESIDENT BROKERAGE  
936.577.0836  
CHRIS@TEXASCRES.COM

