

Office Building For Sale

147 W Broad Street

Lyons, IN 47443



COMMERCIAL REAL ESTATE SERVICES, WORLDWIDE

Well Maintained Former Bank Building



Snapshot

Building:	1,500 SF	Zoning:	No Zoning Ordinance
Land:	0.39 Acres	Ownership Name:	Northwest Bank
Year Built:	1980	Transfer Date:	4/2020
Utilities:	Municipal	Legal Description:	Parcel #28-14-04-224-009.-000-021 Lot 60 Original Lot 61, Washington Township, Greene County, IN
Taxes:	\$223.98 (2019 pay 2020)		
List Price:	\$100,000		

3502 Woodview Trace, Suite 250
Indianapolis, Indiana 46268
317.875.8888
www.cressy.com

Global Brokerage Division of Cressy Commercial Real Estate

JEFFREY S. HARRIS, SIOR
President
(D) 317.566.5610 | (M) 317.331.8888
jharris@cressy.com

Information furnished regarding property for sale, rental or financing is from sources deemed reliable. But no warranty or representation is made as to the accuracy thereof and same is submitted subject to errors, omissions, change of price, rental or other conditions, prior sale, leased, financing or withdrawal without notice. No liability of any kind is to be imposed on the broker herein.

Office Building For Sale

147 W Broad Street

Lyons, IN 47443



Property Photos



3502 Woodview Trace, Suite 250
Indianapolis, Indiana 46268
317.875.8888
www.cressy.com

JEFFREY S. HARRIS, SIOR
President
(D) 317.566.5610 | (M) 317.331.8888
jharris@cressy.com

Global Brokerage Division of Cressy Commercial Real Estate

Information furnished regarding property for sale, rental or financing is from sources deemed reliable. But no warranty or representation is made as to the accuracy thereof and same is submitted subject to errors, omissions, change of price, rental or other conditions, prior sale, leased, financing or withdrawal without notice. No liability of any kind is to be imposed on the broker herein.

Office Building For Sale

147 W Broad Street

Lyons, IN 47443



COMMERCIAL REAL ESTATE SERVICES, WORLDWIDE

Demographics and Floor Plan

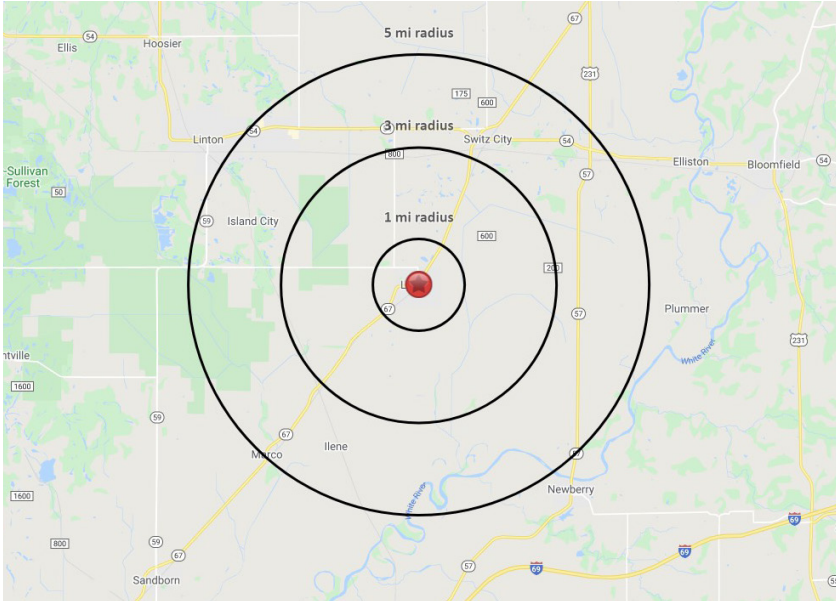

2022 DEMOGRAPHICS	1 MILE	3 MILE	5 MILE
POPULATION	647	905	2,855
NUMBER OF HOUSEHOLDS	265	368	1,192
AVERAGE HOUSEHOLD INCOME	\$91,208	\$87,690	\$70,839

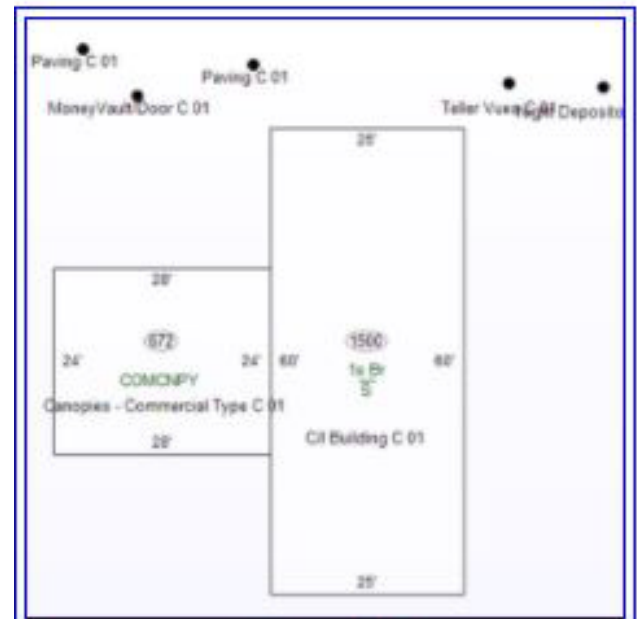

3502 Woodview Trace, Suite 250
 Indianapolis, Indiana 46268
 317.875.8888
 www.cressy.com

JEFFREY S. HARRIS, SIOR
 President
 (D) 317.566.5610 | (M) 317.331.8888
 jharris@cressy.com

Global Brokerage Division of Cressy Commercial Real Estate

Information furnished regarding property for sale, rental or financing is from sources deemed reliable. But no warranty or representation is made as to the accuracy thereof and same is submitted subject to errors, omissions, change of price, rental or other conditions, prior sale, leased, financing or withdrawal without notice. No liability of any kind is to be imposed on the broker herein.