



7220 W. JEFFERSON AVENUE
Lakewood, Colorado 80235



PROPERTY SPECIFICATIONS

- Local ownership and management
- Updated building and common areas
- Abundant nearby amenities
- Connectivity through Comcast
- Convenient location at Hwy 285 and Wadsworth
- Most suites have individual HVAC control

PROPERTY FEATURES

Available:	Suite 407	351 RSF
	Suite 107	739 RSF
	Suite 450	843 RSF
	Suite 200	1,020 RSF
	Suite 409	1,284 RSF
Lease Rate:		\$17.00/RSF FSG
Parking Ratio:		4/1,000 SF
Stories:		Four
Elevators:		One

FOR MORE INFORMATION CONTACT:

RENÉE SPICER
rspicer@gcgcre.com | 720.476.5226

WILLIAM NETWAL
wnetwal@gcgcre.com | 720.476.5228

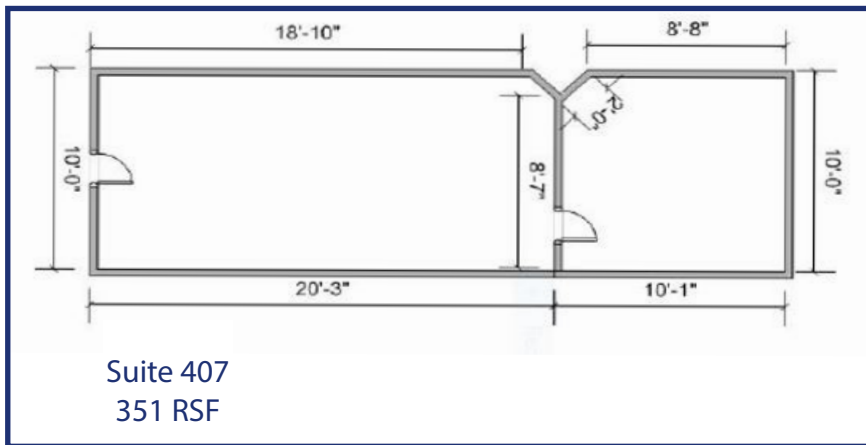
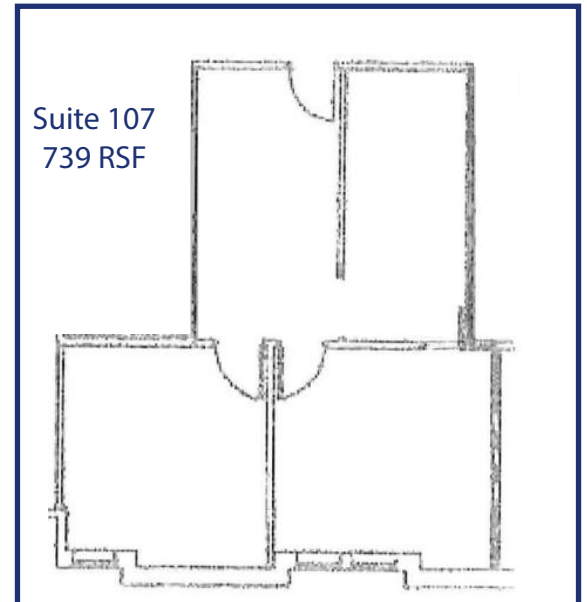
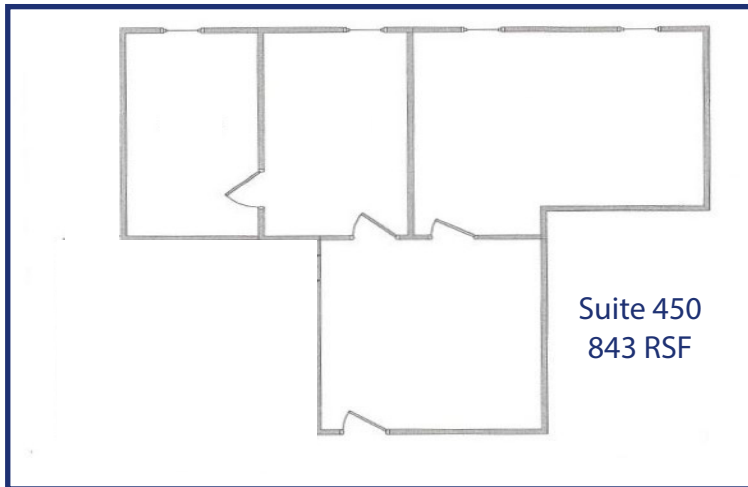
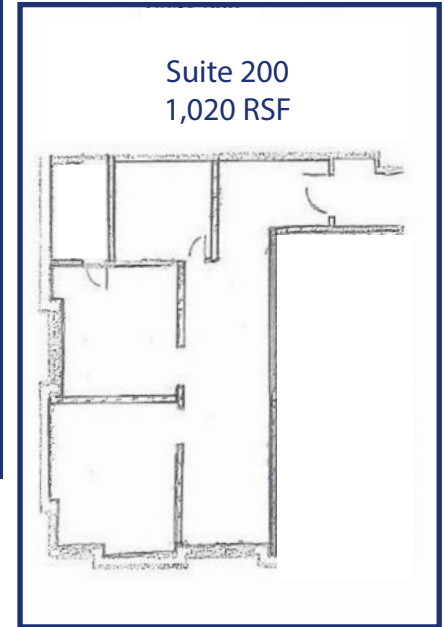
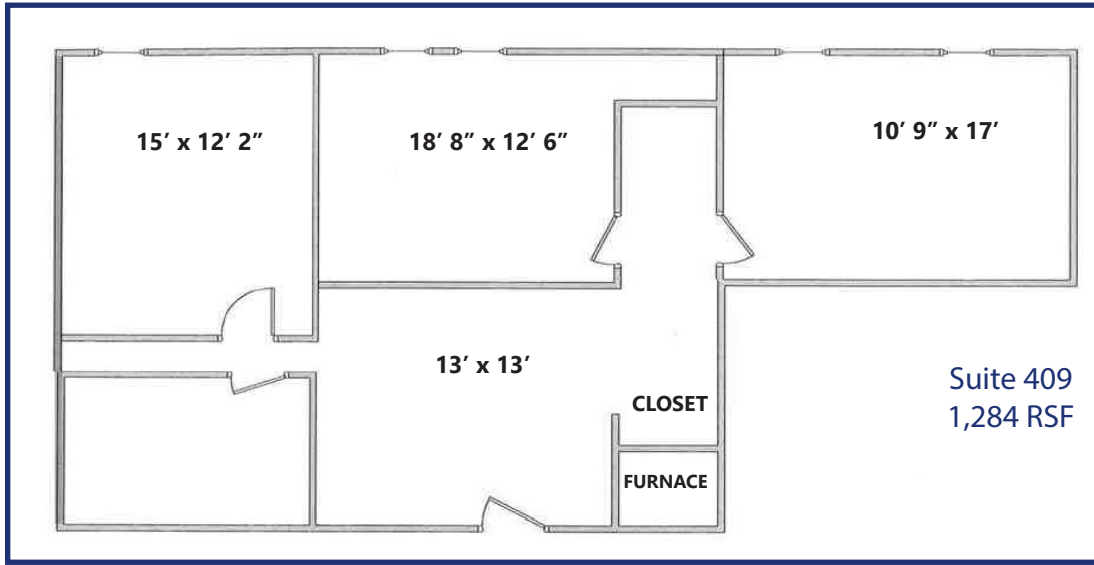

FOR MORE INFORMATION CONTACT:

RENÉE SPICER
rspicer@gcgcre.com | 720.476.5226

WILLIAM NETWAL
wnetwal@gcgcre.com | 720.476.5228