

NEW OFFICES AUGUST 2022

64,941 SF AVAILABLE FOR LEASE

3601 N. MCDONALD STREET

McKinney, Texas 75071



- Suite 200: Spec Office: ± 2,250 SF
- Move-In Ready
- Loading: Rear Load
- Clear Height: 28'
- Sprinkler: ESFR
- Dock Doors: (14) 9' x 10'
- Ramp Door: (1) 14' x 18'
- Seven (7) Pit-Mounted Levelers
- Car Parking: 44
- Lighting: LED in Warehouse
- Truck Court: 130'

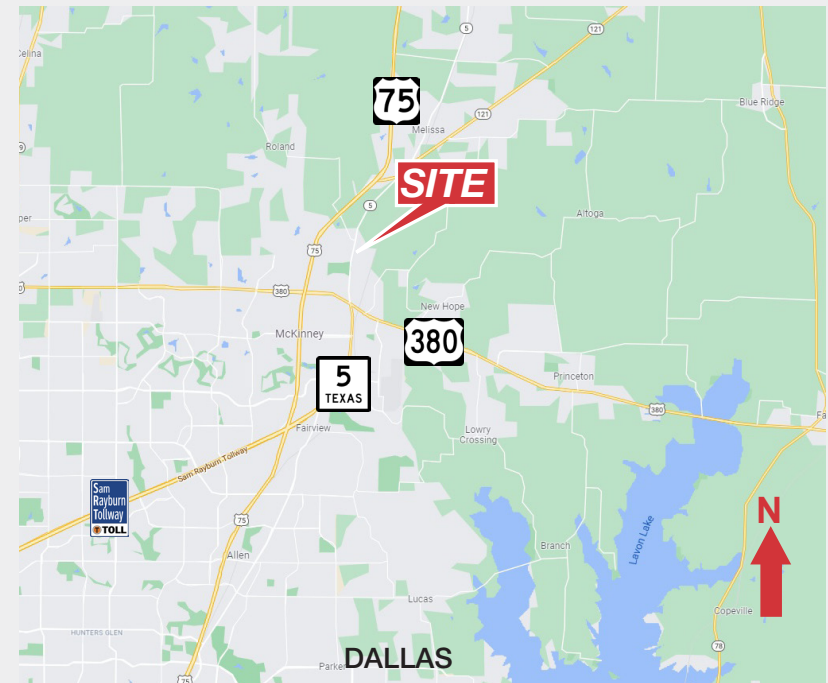

NAI Robert Lynn

4851 LBJ Freeway 10th Floor
Dallas TX 75244
214 256 7100

nairl.com

NEW OFFICES AUGUST 2022

64,941 SF AVAILABLE FOR LEASE

3601 N. MCDONALD STREET

McKinney, Texas 75071

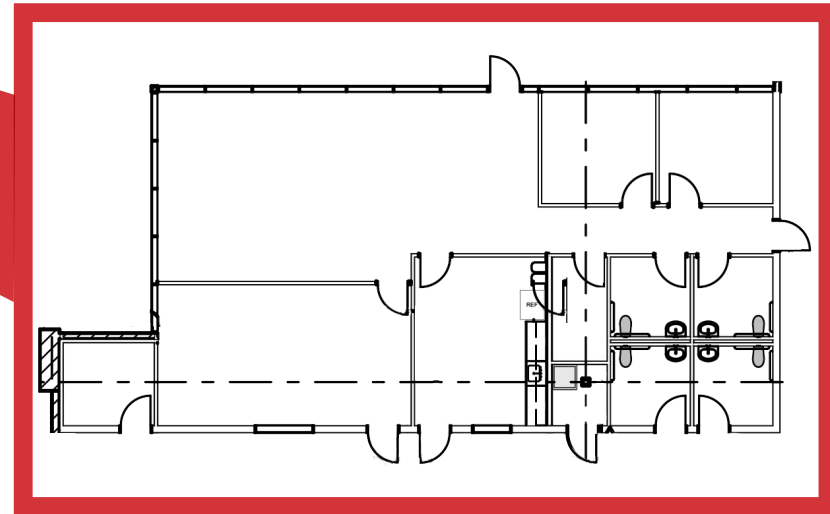
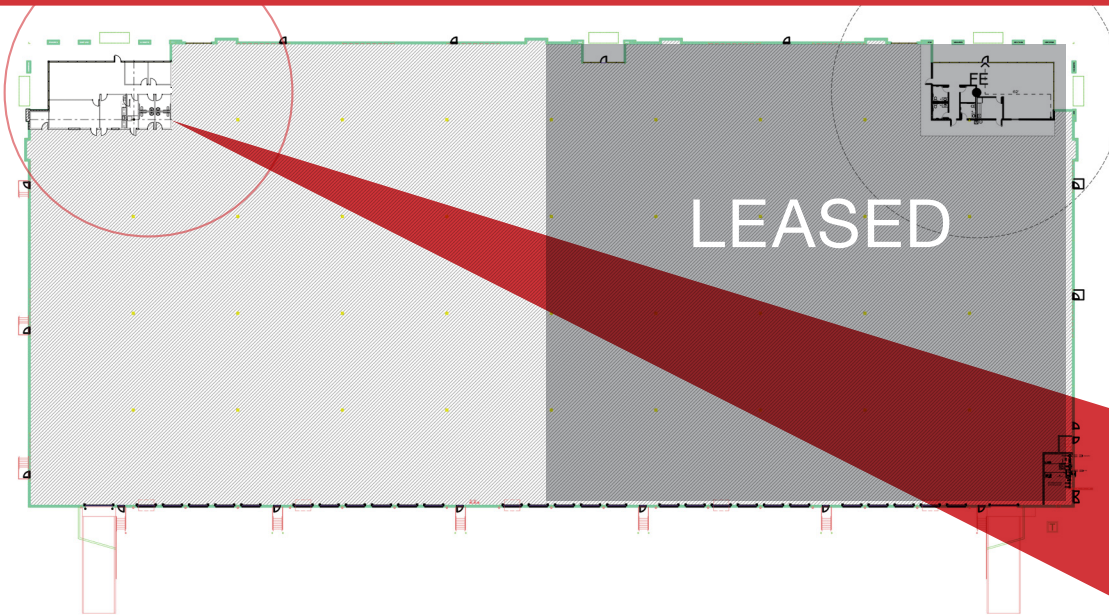

Suite 200
Move-In Ready Spec Office



NEW OFFICES AUGUST 2022

64,941 SF AVAILABLE FOR LEASE

3601 N. MCDONALD STREET

McKinney, Texas 75071



DISTANCE TO:

- 1.4 miles to North Central Expy (US 75)
- 2.3 miles to Hwy 380
- 10.5 miles to SH 121 (Sam Rayburn Tollway)
- 26.1 miles to SH 161 (PGB Turnpike)
- 36 miles to Love Field Airport
- 36.5 miles to Dallas CBD
- 44 miles to DFW International Airport
- 60 miles to Fort Worth CBD



NEW OFFICES AUGUST 2022

64,941 SF AVAILABLE FOR LEASE

3601 N. MCDONALD STREET

McKinney, Texas 75071

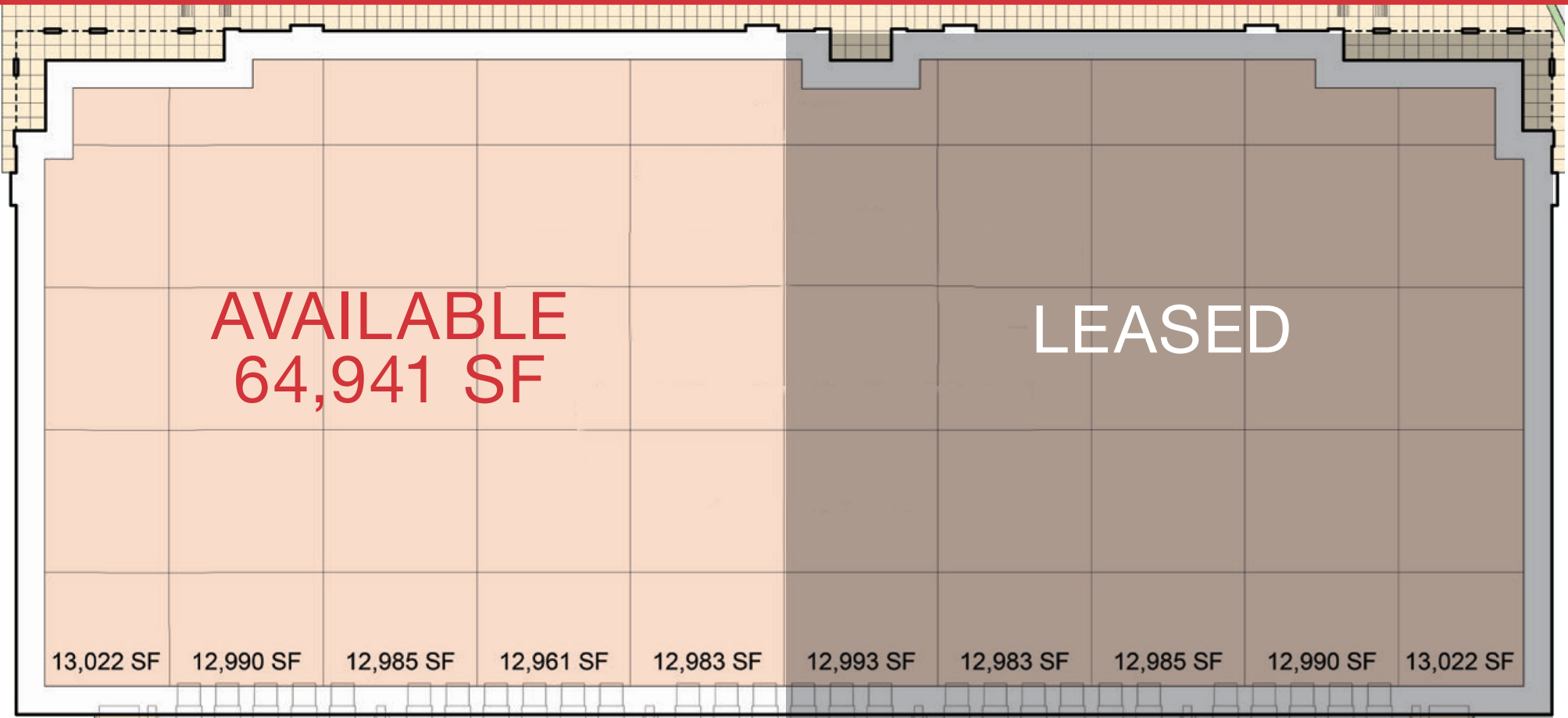

NEW OFFICES AUGUST 2022

64,941 SF AVAILABLE FOR LEASE

3601 N. MCDONALD STREET

McKinney, Texas 75071



Dave Peterson

214 256 7129 Office
972 922 5680 Cell
dpeterson@nairl.com

Stephen Cooper, SIOR

214 256 7160 Office
214 497 0730 Cell
scooper@nairl.com

Matt Elliott, SIOR

214 256 7161 Office
214 288 7386 Cell
melliott@nairl.com



NAI Robert Lynn

THE INFORMATION CONTAINED HEREIN HAS BEEN GIVEN TO US BY THE OWNER OF THE PROPERTY OR OTHER SOURCES WE DEEM RELIABLE. WE HAVE NO REASON TO DOUBT ITS ACCURACY, BUT WE DO NOT GUARANTEE IT. ALL INFORMATION SHOULD BE VERIFIED PRIOR TO PURCHASE OR LEASE.

4851 LBJ Freeway 10th Floor
Dallas TX 75244
214 256 7100
nairl.com