

RETAIL FOR LEASE OAKBROOK MARKETPLACE

6066 Limaburg Road, Burlington, KY 41005



Your Company Name Here

OFFERING SUMMARY

AVAILABLE SF:	3,120 SF
LEASE RATE:	\$4,810 MG
LOT SIZE:	4.14 Acres
YEAR BUILT:	1989
ZONING:	C-1



PROPERTY HIGHLIGHTS

- In-line retail space available in popular Oakbrook Marketplace anchored by United Dairy Farmers
- Available Parking: 4.44/1,000 SF
- Frontage: 812" on Limaburg Road (with 3 curb cuts)
- Located in the county seat of Boone County, KY
- Will divide square footage (2080 SF)

George Flynn
gflynn@lee-associates.com
D 513.588.1126

Stewart Devitt
stewart.devitt@lee-associates.com
D 513.588.1115

Dan McDonald
dan.mcdonald@lee-associates.com
D 513.588.1113

All information furnished regarding property for sale, rental or financing is from sources deemed reliable, but no warranty or representation is made to the accuracy thereof and same is submitted to errors, omissions, change of price, rental or other conditions prior to sale, lease or financing or withdrawal without notice. No liability of any kind is to be imposed on the broker herein.



RETAIL FOR LEASE OAKBROOK MARKETPLACE

6066 Limaburg Road, Burlington, KY 41005

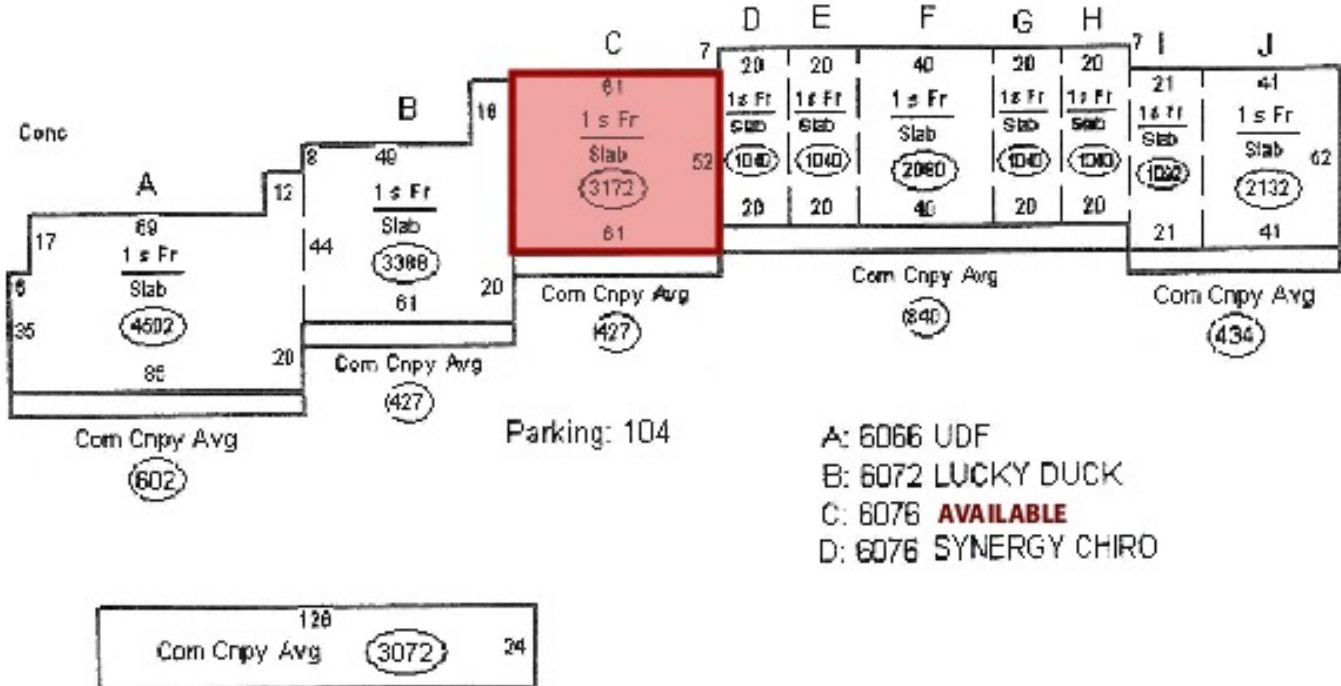

George Flynn
gflynn@lee-associates.com
D 513.588.1126

Stewart Devitt
stewart.devitt@lee-associates.com
D 513.588.1115

Dan McDonald
dan.mcdonald@lee-associates.com
D 513.588.1113

All information furnished regarding property for sale, rental or financing is from sources deemed reliable, but no warranty or representation is made to the accuracy thereof and same is submitted to errors, omissions, change of price, rental or other conditions prior to sale, lease or financing or withdrawal without notice. No liability of any kind is to be imposed on the broker herein.

RETAIL FOR LEASE OAKBROOK MARKETPLACE

6066 Limaburg Road, Burlington, KY 41005



George Flynn
gflynn@lee-associates.com
D 513.588.1126

Stewart Devitt
stewart.devitt@lee-associates.com
D 513.588.1115

Dan McDonald
dan.mcdonald@lee-associates.com
D 513.588.1113

All information furnished regarding property for sale, rental or financing is from sources deemed reliable, but no warranty or representation is made to the accuracy thereof and same is submitted to errors, omissions, change of price, rental or other conditions prior to sale, lease or financing or withdrawal without notice.
No liability of any kind is to be imposed on the broker herein.

RETAIL FOR LEASE OAKBROOK MARKETPLACE

6066 Limaburg Road, Burlington, KY 41005

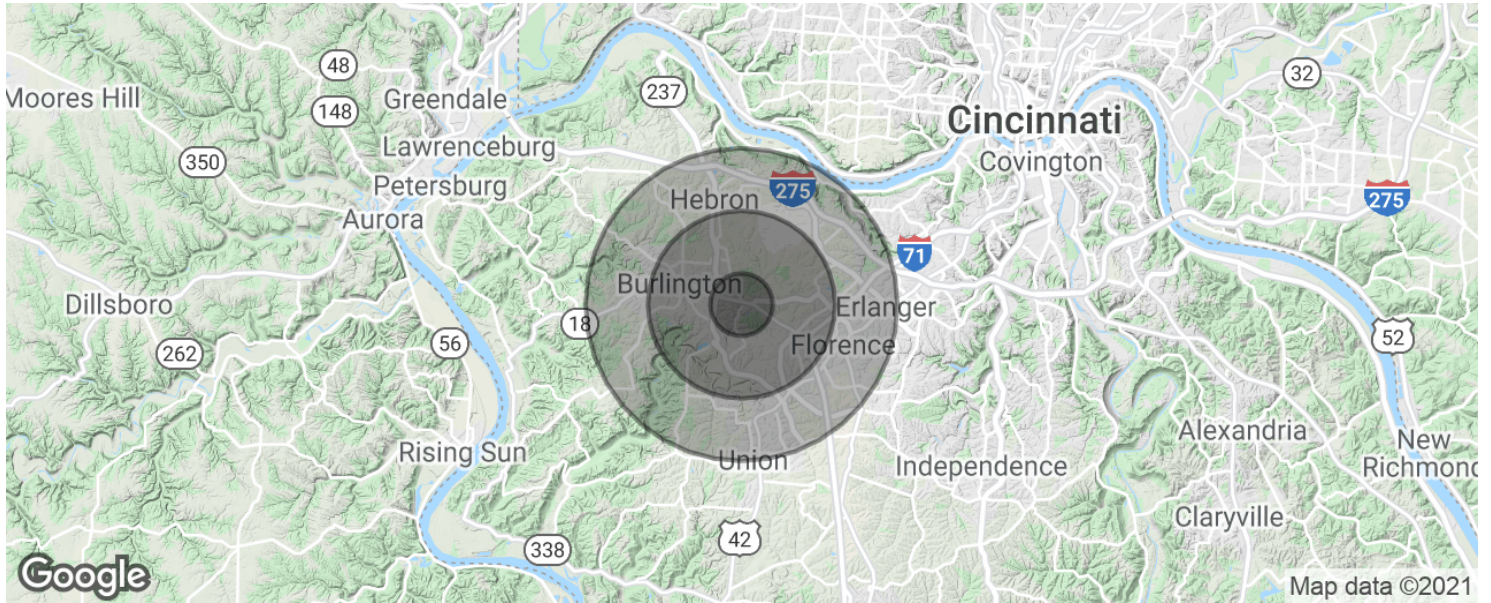

POPULATION	1 MILE	3 MILES	5 MILES
Total population	5,339	35,402	83,322
Median age	38.0	36.2	35.5
Median age (Male)	37.4	34.4	34.2
Median age (Female)	38.4	37.4	36.5
HOUSEHOLDS & INCOME	1 MILE	3 MILES	5 MILES
Total households	2,245	13,603	31,767
# of persons per HH	2.4	2.6	2.6
Average HH income	\$70,951	\$74,916	\$70,591
Average house value	\$153,180	\$179,254	\$184,769

* Demographic data derived from 2010 US Census

George Flynn
gflynn@lee-associates.com
D 513.588.1126

Stewart Devitt
stewart.devitt@lee-associates.com
D 513.588.1115

Dan McDonald
dan.mcdonald@lee-associates.com
D 513.588.1113

All information furnished regarding property for sale, rental or financing is from sources deemed reliable, but no warranty or representation is made to the accuracy thereof and same is submitted to errors, omissions, change of price, rental or other conditions prior to sale, lease or financing or withdrawal without notice. No liability of any kind is to be imposed on the broker herein.