

OM-2187

100710 – Original

HOBART[®]
GROUND POWER

Operation and Maintenance Manual
with
Illustrated Parts List
for

POWERMASTER[®] ADV

Series 500048B



120 kVA with 12-Pulse
and 400/480V Input Voltage
Solid State Frequency Converters

Hobart Ground Power
Troy, Ohio 45373
U.S.A.



Warranty

Data Sheet 165
Index: 990223
Replaces: 980601

HOBART GROUND POWER
TROY, OHIO 45373

1. Hobart Brothers Company (hereinafter called HOBART) warrants that each new and unused Hobart Ground Power Equipment, (hereinafter called the PRODUCT) is of good workmanship and is free from mechanical defects, provided that (1) the PRODUCT is installed and operated in accordance with the printed instructions of HOBART, (2) the PRODUCT is used under the normal operating conditions for which it is designed, (3) the PRODUCT is not subjected to misuse, negligence or accident, and (4) the PRODUCT receives proper care, lubrication, protection, and maintenance under the supervision of trained personnel.
2. This warranty expires 15 months after shipment by HOBART to the first user, or 12 months after installation, whichever first occurs.
3. This warranty does not apply to: primary and secondary switch contacts, cable connectors, carbon brushes, fuses, bulbs, and filters unless found to be defective prior to use.
4. Hobart DOES NOT WARRANT THE FOLLOWING COMPONENTS: Engines, engine components; such as: starters, alternators, regulators, governors, etc., and cable retrieving devices. Many of the foregoing components are warranted directly by the manufacturer to the first user and serviced by a worldwide network of distributors and others authorized to handle claims for component manufacturers. A first user's claim should be presented directly to such an authorized component service outlet. In the event any component manufacturer has warranted its component to HOBART and will not deal directly with a first user then HOBART will cooperate with the first user in the presentation of a claim to such manufacturer. Under NO circumstances does HOBART assume any liability for any warranty claim against or warranty work done by or in behalf of any manufacturer of the foregoing components.
5. This warranty is extended by HOBART only to the purchaser of new PRODUCTS from HOBART or one of its authorized distributors. The PRODUCTS purchased under this warranty are intended for use exclusively by the buyer and his employees and by no other persons and, therefore, there shall be no third party beneficiary to this warranty.
6. A claim of defects in any PRODUCT covered by this warranty is subject to HOBART factory inspection and judgment. HOBART'S liability is limited to repair of any defects found by HOBART to exist, or at HOBART'S option the replacement of the defective product, F.O.B. factory, after the defective product has been returned by the purchaser at its expense to HOBART'S shipping place. Replacement and exchange parts will be warranted for the remainder of the original Warranty, or for a period of ninety (90) days, whichever is greater.
7. UNDER NO CIRCUMSTANCES whatsoever shall HOBART and its authorized distributors be liable for any special or consequential damages, whether based on lost goodwill, lost resale profits, work stoppage impairment of other goods or otherwise, and whether arising out of breach of any express or implied warranty, breach of contract, negligence or otherwise, except only in the case of personal injury as may be required by applicable law.
8. Continued use of the PRODUCT(S) after discovery of a defect VOIDS ALL WARRANTIES.
9. Except as authorized in writing, this warranty does not cover any equipment that has been altered by any party other than HOBART.
10. THERE ARE NO WARRANTIES WHICH EXTEND BEYOND THE DESCRIPTION ON THE FACE HERE OF. HOBART MAKES NO WARRANTIES, EXPRESSED OR IMPLIED, OF MERCHANTABILITY OR FITNESS FOR A PARTICULAR PURPOSE.
11. HOBART neither assumes nor authorizes any person to assume for HOBART any liability in connection with the PRODUCTS sold, and there are no oral agreements or warranties collateral to or affecting this written Warranty. This warranty and all undertakings of HOBART thereunder shall be governed by the laws of the State of Ohio, United States of America.

WARNING: AT ALL TIMES, SAFETY MUST BE CONSIDERED AN IMPORTANT FACTOR IN THE INSTALLATION, SERVICING AND OPERATION OF THE PRODUCT, AND SKILLED, TECHNICALLY QUALIFIED PERSONNEL SHOULD ALWAYS BE EMPLOYED FOR SUCH TASKS.

Safety Warnings and Cautions

WARNING

ELECTRIC SHOCK can **KILL**. Do not touch live electrical parts.

ELECTRIC ARC FLASH can injure eyes, burn skin, cause equipment damage, and ignite combustible material. **DO NOT** use power cables to break load. Prevent tools from causing short circuits.

IMPROPER PHASE CONNECTION, PARALLELING, OR USE can damage this and attached equipment.

Follow all requirements in NFPA 70E for safe work practices and for Personal Protective Equipment (PPE).

IMPORTANT

Protect all operating personnel. Read, understand, and follow all instructions in the Operating/Instruction Manual before installing, operating, or servicing the equipment. Keep the manual available for future use by all operators.

1) General

Equipment that supplies electrical power can cause serious injury or death, damage to other equipment or property. The operator must strictly observe all safety rules and take precautionary actions. Safe practices have been developed from past experience in the use of power source equipment. While certain practices below apply only to electrically powered equipment, other practices apply to engine-driven equipment, and some practices to both.

2) Shock Prevention

Bare conductors, terminals in the output circuit, or ungrounded, electrically live equipment can fatally shock a person. Have a certified electrician verify that the equipment is adequately grounded and learn what terminals and parts are electrically **HOT**. Avoid hot spots on machine. Use proper safety clothing, procedures, and test equipment.

The electrical resistance of the body is decreased when wet, permitting dangerous currents to flow through it. When inspecting or servicing the equipment, do not work in damp areas. Stand on a dry rubber mat or dry wood, and use insulating gloves when dampness or sweat cannot be avoided. Keep clothing dry, and never work alone.

a) Installation and Grounding of Electrically Powered Equipment

This equipment must be installed and maintained in accordance with the National Electrical Code, ANSI/NFPA 70, or other applicable codes. A power disconnect switch or circuit breaker must be located at the equipment. Check the nameplate for voltage, frequency, and phase requirements. If only 3-phase power is available, connect any single-phase rated equipment to only two wires of the 3-phase line. **DO NOT CONNECT** the equipment grounding conductor (lead) to the third live wire of the 3-phase line, as this makes the equipment frame electrically **HOT**, which can cause a fatal shock.

Always connect the grounding lead, if supplied in a power line cable, to the grounded switch box or building ground. If not provided, use a separate grounding lead. Ensure that the current (amperage) capacity of the grounding lead will be adequate for the worst fault current situation. Refer to the National Electrical Code ANSI/NFPA 70 for details. Do not remove plug ground prongs and use correctly mating receptacles.

b) Output Cables and Terminals

Inspect cables frequently for damage to the insulation and the connectors. Replace or repair cracked or worn cables immediately. Do not overload cables. Do not touch output terminal while equipment is energized.

3) Service and Maintenance

This equipment must be maintained in good electrical condition to avoid hazards stemming from disrepair. Report any equipment defect or safety hazard to the supervisor and discontinue use of the equipment until its safety has been assured. Repairs should be made by qualified personnel only. Before inspecting or servicing this equipment, take the following precautions:

- a)** Shut off all power at the disconnecting switch, or line breaker, or by disconnecting battery, before inspecting or servicing the equipment.
- b)** Lock switch OPEN (or remove line fuses) so that power cannot be turned on accidentally.
- c)** Disconnect power to equipment if it is out of service.
- d)** If troubleshooting must be done with the unit energized, have another person present who is trained in turning off the equipment and providing or calling for first aid.

4) Fire And Explosion Prevention

Fire and explosion are caused by arc flash events, electrical short circuits, combustible material near this equipment, or unsafe operating conditions. Overloaded or shorted equipment can become hot enough to cause fires by self destruction or by causing nearby combustibles to ignite. For electrically powered equipment, provide primary input protection to remove short circuited or heavily overloaded equipment from the line.

5) Bodily Injury Prevention

Serious injury can result from contact with fans or hot spots inside some equipment. Shut **DOWN** such equipment for inspection and routine maintenance. When equipment is in operation, use extreme care in doing necessary troubleshooting and adjustment. Do not remove guards while equipment is operating.

6) Medical and First Aid Treatment

First aid facilities and a qualified first aid person should be available for each shift for immediate treatment of all injury victims. Electric shock victims should be checked by a physician and taken to a hospital immediately if any abnormal signs are observed.

**EMERGENCY
FIRST AID**

Call physician immediately. Seek additional assistance. Use First Aid techniques recommended by American Red Cross until medical help arrives.

IF BREATHING IS DIFFICULT, give oxygen, if available, and have victim lie down. **FOR ELECTRICAL SHOCK**, turn off power. Remove victim; if not breathing, begin artificial respiration, preferably mouth-to-mouth. If no detectable pulse, begin external heart massage. **CALL EMERGENCY RESCUE SQUAD IMMEDIATELY.**

7) Equipment Precautionary Labels

Inspect all precautionary labels on the equipment monthly. Order and replace all labels that cannot be easily read.

This page intentionally left blank.

Introduction

This manual contains operation and maintenance information for a 400 Hz Solid State Converter manufactured by Hobart Ground Power, Troy, Ohio 45373.

This manual, including all information contained thereon, is exclusive and confidential property of Hobart Ground Power. This manual is not to be copied, reproduced, or delivered or disclosed to others, in whole or in part, except with express written permission of Hobart Ground Power.

This manual is not intended to be a textbook on electricity or electronics. Its primary purpose is to provide information and instructions to experienced operators, electricians, and mechanics that have never operated this equipment. It is the intent of this manual to guide and assist operators and maintenance personnel in the proper use and care of the equipment.

Use of the manual should not be put off until trouble or a need for help develops. Read the instructions before starting the unit. Learn to use the manual and to locate information contained in it. Its style and arrangement are very similar to commercial aircraft manuals.

The manual is divided into five chapters plus an appendix. Each chapter is divided into as many sections as required. Each new section starts with page 1. Each page is identified by chapter, section and page number, which are located in the lower, outside corner.

When information located in another portion of the manual is referred to, a chapter, section, and paragraph or figure number identify its location. For example: "(see Section 2-3, Paragraph 1.a.)" refers to information located in Chapter 2, Section 3, Paragraph 1.a. If a chapter and section are not indicated in a reference, the referenced material is located in the same section as the reference, for example: "(see Paragraph 1.a.)"

The appendix is the last section. It contains a list of available options that may be purchased or have been purchased with that unit. Items on the list with check marks next to them have been added to the standard unit per the customer's order. Literature for each option follows. The appendix will help control the information in the manual making it unique to the unit purchased.

In addition to operation and maintenance instructions, the manual contains an illustrated parts list in Chapter 4 and a collection of manufacturer's literature and supplemental information in Chapter 5.

Contents of the manual are arranged as follows:

Chapter 1 Description/Operation

Chapter 2 Servicing/Troubleshooting

Chapter 3 Overhaul/Major Repair

Chapter 4 Illustrated Parts List

Chapter 5 Manufacturer's Literature

Appendix A Options

OM-2187 / Operation and Maintenance Manual
PoWerMaster[®] ADV / Series 500048B / Solid State Converter

If you have any questions concerning your Hobart Ground Power equipment, immediately contact our Service Department by mail, telephone, FAX, or E-Mail.

Write: Hobart Ground Power
Service Department
1177 Trade Square East
Troy, Ohio 45373
U.S.A.

Call Inside U.S.A.: (800) 422-4166 (Parts)
(800) 422-4177 (Service)

Call From Foreign Countries: (937) 332-5050 (Parts)
(937) 332-5060 (Service)

FAX Inside U.S.A. (800) 367-4945

FAX From Foreign Countries: (937) 332-5121

E-Mail : service@hobartgroundpower.com

Web Page : www.hobartgroundpower.com

Table of Contents

Chapter 1	Description/Operation	Chapter-Section/Page#
Section 1	Description	1-1/1
	<i>General</i>	1-1/1
	<i>Optional Equipment - Appendix A</i>	1-1/1
	<i>Orientation</i>	1-1/1
	<i>Mounting for the Converter</i>	1-1/1
	<i>Safety Features</i>	1-1/5
	<i>Bridge Interlock Circuit</i>	1-1/5
	<i>Converter Cabinet</i>	1-1/5
	<i>Theory of Operation</i>	1-1/5
	<i>ADV Control System</i>	1-1/9
	<i>Event Records/Fault Monitoring</i>	1-1/10
	<i>Detailed Description of Converter Components</i>	1-1/10
Section 2	Preparation for Use, Storage or Shipping	1-2/1
	<i>Receipt and Inspection of Equipment</i>	1-2/1
	<i>Unpacking the Unit</i>	1-2/1
	<i>Input Cable Size and Temperature Requirements</i>	1-2/1
	<i>Installation</i>	1-2/2
	<i>Preparation for Storage</i>	1-2/7
	<i>Preparation for Shipment</i>	1-2/8
Section 3	Operation	1-3/1
	<i>General</i>	1-3/1
	<i>115 V AC, 400 Hz. Operation</i>	1-3/1
Chapter 2	Servicing / Troubleshooting	Chapter-Section/Page#
Section 1	Troubleshooting	2-1/1
	<i>General</i>	2-1/1
	<i>ADV Control Monitoring</i>	2-1/2
	<i>Troubleshooting Tables</i>	2-1/7
	<i>Troubleshooting Procedures</i>	2-1/17

Section 2	Calibration	2-2/1
	<i>Test Preparation</i>	2-2/1
	<i>Calibration</i>	2-2/3
Section 3	Scheduled Maintenance	2-3/1
	<i>General</i>	2-3/1
	<i>Scheduled Maintenance Procedure</i>	2-3/1

Chapter 3 Overhaul / Major Repair **Chapter-Section/Page#**

Section 1	Unscheduled Repair	3-1/1
	<i>General</i>	3-1/1
	<i>Service Information and Factory Repair</i>	3-1/1
	<i>Workmanship</i>	3-1/2
	<i>Converter Bridge Mount Removal and Installation</i>	3-1/2
	<i>Component Removal and Replacement</i>	3-1/4
	<i>PC Board Removal and Replacement</i>	3-1/9

Chapter 4 Illustrated Parts List **Chapter-Section/Page#**

Section 1	Introduction	4-1/1
	<i>General</i>	4-1/1
	<i>Purpose</i>	4-1/1
	<i>Arrangement</i>	4-1/1
	<i>Explanation of Parts List</i>	4-1/1
Section 2	Manufacture's Codes	4-2/1
	<i>Explanation of Manufacture's (Vendor) Code List</i>	4-2/1
Section 3	Illustrated Parts List	4-3/1
	<i>Explanation of Parts List Arrangement</i>	4-3/1
	<i>Symbols and Abbreviations</i>	4-3/1
	<i>Figure 1: PoWerMaster ADV Converter</i>	4-3/2
	<i>Figure 2: Frame Assembly</i>	4-3/4
	<i>Figure 3: Front Interior Components</i>	4-3/6
	<i>Figure 4: Heat Sink Panel Assembly</i>	4-3/8
	<i>Figure 5: Rear Interior Components</i>	4-3/10

Section 3 (cont.)	<i>Figure 6: Fan Assembly Components</i>	4-3/12
	<i>Figure 7: DC Electrolytic Capacitors Assembly</i>	4-3/14
	<i>Figure 8: AC Capacitor Assembly</i>	4-3/16
	<i>Figure 9: Contactor Panel Assembly</i>	4-3/18
	<i>Figure 10: Canopy Components</i>	4-3/20
Section 4	Numerical Index	4-4/1
	<i>Explanation of Numerical Index</i>	4-4/1

Chapter 5 Manufacture's Literature

Appendix A Options/Features

Unusual Service Conditions

This page intentionally left blank.

Chapter 1 Description/Operation

Section 1 Description

1) General

The PoWerMaster ADV Solid State Frequency Converter, covered by this manual, is manufactured by Hobart Ground Power, Troy, Ohio 45373. The converter is designed to provide ground power for maintenance and startup of aircraft having 115/200-V AC, 3-phase, 400-Hz AC.

The number 500048B identifies the “model or series” of the converter. The part number is followed by a dash number, which separates the basic units available. The criteria for input voltages, amps, and frequency will change with each dash number. Figure 1 uses the part number to identify the possible variations covered by this manual.

Part & Dash Number	Ratings	Outputs	Input Voltage	Frequency
500048B-52220	120	2	480 V	50/60

Series 500048B Converters Part Number Descriptions
Figure 1

The Hobart PoWerMaster ADV is designed to service aircraft equipped with No-Break Power Transfer (NBPT). Advanced electronic circuitry allows the unit to automatically synchronize with onboard power during NBPT, providing successful transfers every time.

2) Optional Equipment - Appendix A

Chapters 1 through 5 of this Operation and Maintenance Manual identify only the basic version of a Series 500048B converter. Component differences between the different machines will be listed when necessary. A list of optional equipment, which makes this manual unique to the converter that you have purchased, appears in Appendix A. Examples of items located in Appendix A are trailer mounting kits and bridge mounting brackets.

3) Orientation (See Figure 2)

To avoid confusion in the location of components, the control panel is considered to be at the front of the unit. Left and right are determined by looking at the unit from the front.

4) Mounting for the Converter

The ADV converter must be mounted vertically on a floor stand.

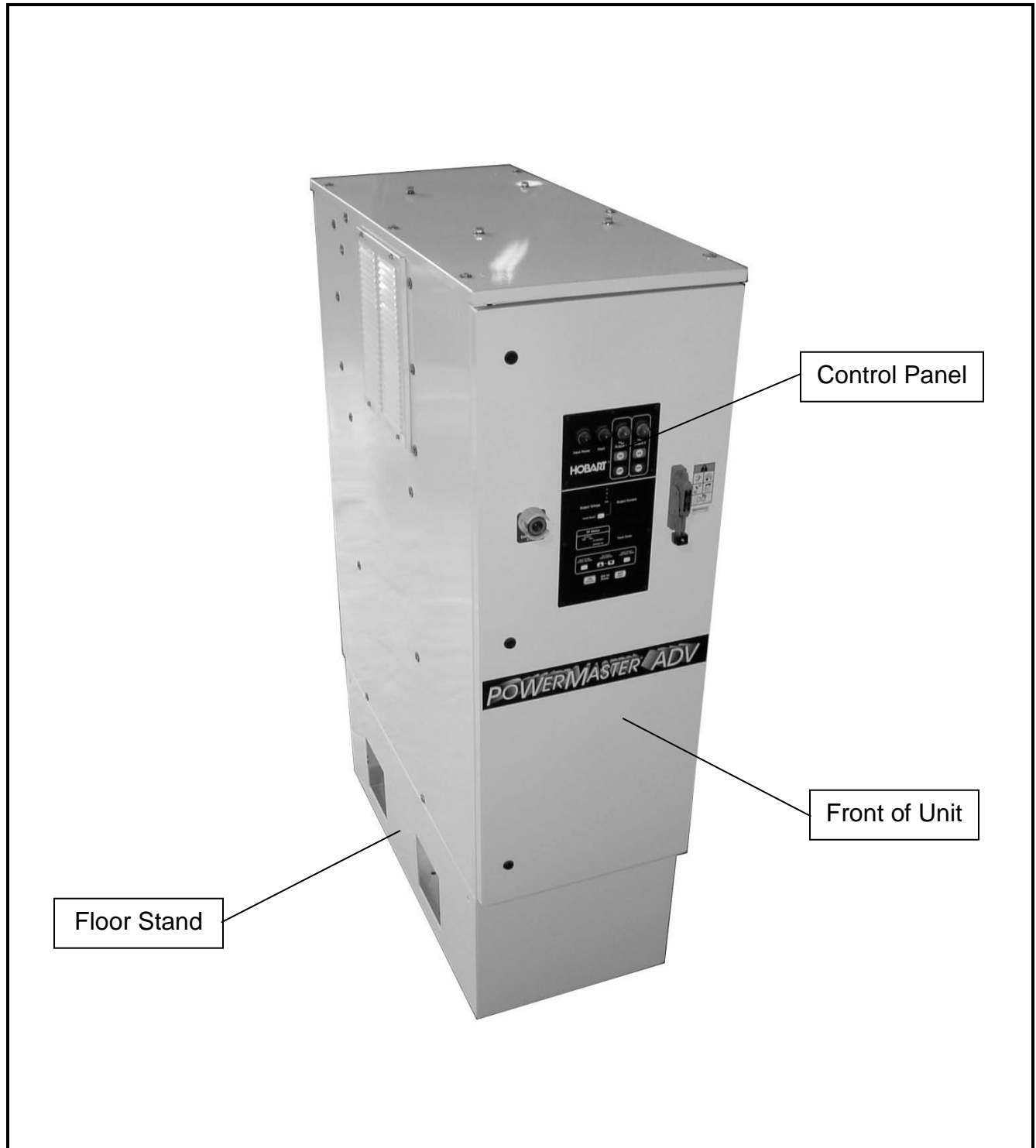

**Hobart PoWerMaster[®] ADV Solid State Frequency Converter
Figure 2**

PHYSICAL			
Enclosure	NEMA 3R or IEC IP 54		
Weight (Approximate)	Dual Output		
...Standard	2053 lb (931 kg)		
SIZE			
	Length	Width	Height
Standard Unit (with floor stand)	51 inches 129.5 (cm)	23 inches 58.9 (cm)	78 inches 198.1 (cm)
ENVIRONMENTAL			
Acoustical noise	Less than 65 dBA @ 1.5 m high, 2 m distance		
Operating temperature	-40° to +52° C (-40° to +125° F)		
Storage temperature	-40° to +62° C (-40° to +140° F)		
Relative humidity	10 to 100% non-condensing		
ELECTRICAL INPUT			
kVA Rating	120 (96 kW)		
Voltage (nominal) VAC	400 / 480		
Frequency (Hz)	50 / 60		
Amperes (rated load)	154 / 134		
Voltage Range (maximum)	340 / 530		
Starting Current	Less than 100% full load input current		
Power Factor	More than 0.98 lagging from 10% to full load		

Specifications and Capabilities
Figure 3

ELECTRICAL OUTPUT	
kVA Rating (continuous)	120 (96 kW)
Voltage VAC	115/200
Frequency (Hz)	400
Amperes (at rated load per power ratings)	347
Overload Trips	<ul style="list-style-type: none"> • at 125% after 10 minutes • at 150% after 30 seconds • at 200% after 10 seconds
Shorted output shutdown	Immediate
Duty Cycle	100%
Total harmonic distortion (THD)	Less than 3%
Individual harmonic distortion (IHD)	Less than 2%
DC Content	Less than 100 mV
Frequency Drift	± 0.05%
Phase Displacement	120° ± 1.5°
Transient performance	Meets MIL-STD-704 latest version
Voltage adjustment range	± 15% of rated voltage
Phase voltage balance (with balanced load)	Phase voltage balance (with balanced load) Less than 2% of rated line/neutral voltage
Voltage unbalance (10% unbalanced load on one phase)	Less than 3 V (meets MIL-STD-704 latest version)
Voltage regulation	Less than 1% from no load to rated load
Crest Factor	1.414 ± 0.07
Line drop compensation	Automatic, up to 8% of rated voltage at maximum rated load
Frequency modulation	Less than ± 0.25% of the period of output voltage wave

Specifications and Capabilities (continued)
Figure 3

5) Safety Features

The Hobart control system provides the highest available level of protection and safety for the operator, the aircraft, and the converter itself. The ADV performs complete diagnostic testing upon each startup and continuous monitoring of all critical circuits and operating electrical values, as well as, automatically shutting down the converter, if a fault occurs, in order to minimize risks to the user, aircraft, and converter.

See Chapter 2 for troubleshooting details and the types and levels of protection provided by the control system.

6) Bridge Interlock Circuit

For safety, and to prevent damage to equipment, the converter can be interlocked with the bridge drive circuitry so that the bridge cannot be moved on the apron while the converter is operating. This is done to prevent the bridge from pulling the output cable from the airplane or driving over the cable.

7) Converter Cabinet (See Figure 2)

The cabinet, which houses the converter apparatus and circuitry, is a NEMA 3R or IEC IP 54 enclosure, which means that it is weather resistant. It consists of a sturdy welded steel frame with an aluminum enclosure fastened to the sides and top. Aluminum front and rear doors are hinged to permit opening the unit for easy access to serviceable components.

8) Theory of Operation (See Figure 4, 5, 6, 7, and 8)

a) Input Rectifier

The input rectifier consists of a three phase thyristor/rectifier bridge which is phase angle regulated during startup providing a soft start of the converter. This limits the inrush current to less than the full rated value of the converter. During normal operation, the thyristor/rectifiers operate at full conduction to behave as a standard 3-phase bridge rectifier. The bridge produces an unregulated DC voltage (approximately 650 volts) which is passed through a filter before it is applied to the inverter. The converter is protected against input line voltage surges by a three phase voltage snubber network connected across the AC input of the bridge and a voltage suppresser across the DC output of the rectifier bridge.

b) Input Filter and DC Bus Capacitor Bank

The input filter consists of two filter inductors and a bank of capacitors to provide the inverter with a low ripple DC voltage. One inductor is in the positive output of the rectifier bridge and one is in the negative output of the rectifier bridge. The capacitor bank consists of electrolytic and high frequency film capacitors connected in parallel but strategically located to utilize the advantages of each fully. The high frequency film capacitors exhibit low capacitance, extremely low series inductance with high ripple current capacity and are mounted directly across the inverter with a low inductance bus. The electrolytic capacitors, which have high capacitance but low ripple current capabilities, are remotely located and serve as energy storage and input rectifier filter for the DC bus. Because of the limited voltage rating of electrolytic capacitors, two capacitors are connected in series with a voltage balancing resistor across each capacitor to achieve a 900 volt capability.

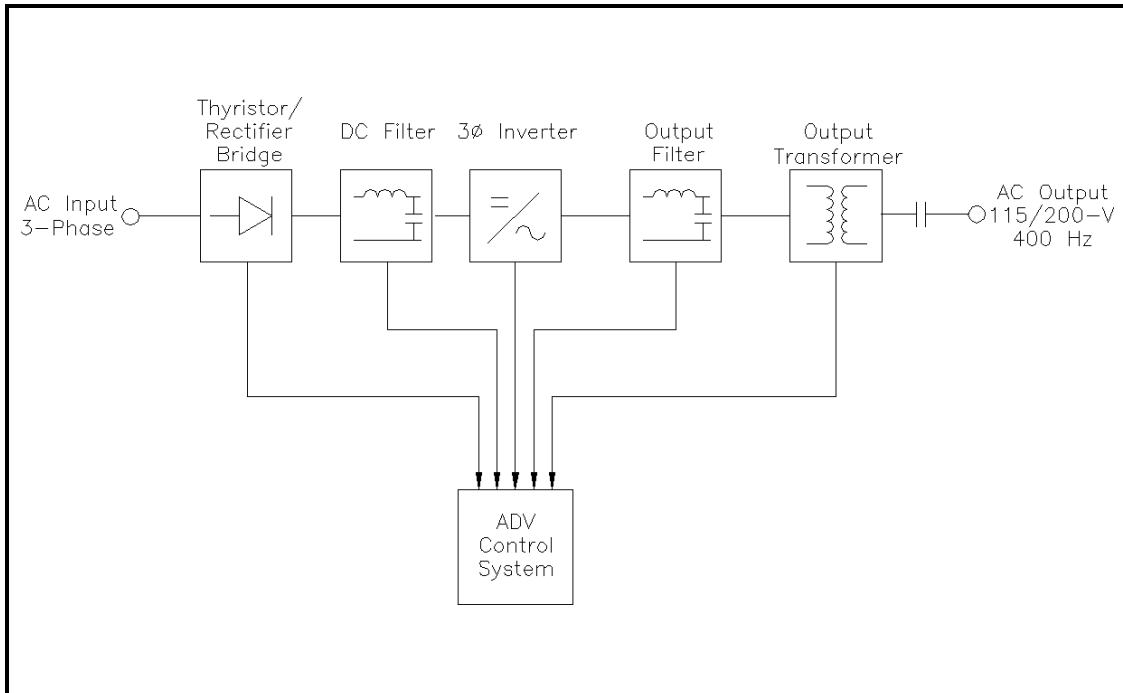

Simplified Block Diagram of Converter
Figure 4

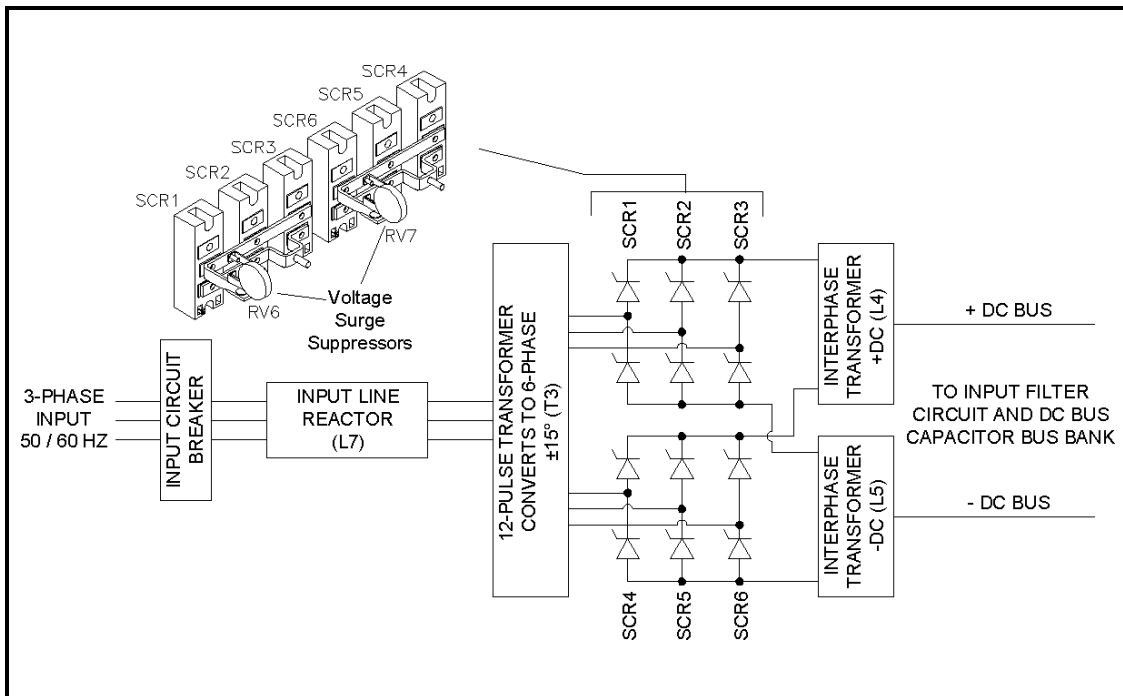

Input Thyristor/Rectifier Circuit
Figure 5

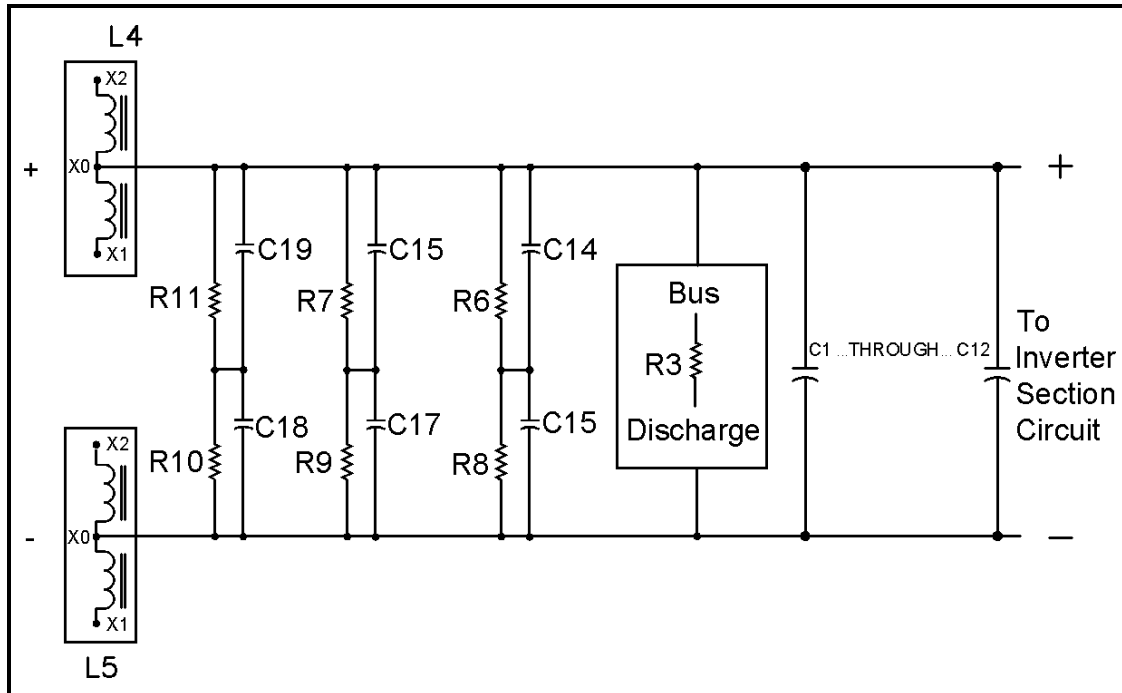

Input Filter Circuit and DC Bus Capacitor Bank
Figure 6

c) Discharge Circuit

The discharge circuit consists of a high power, low value resistor that will discharge the DC bus to 30 volts in less than 3 seconds. An IGBT (Insulated Gate Bipolar Transistor) switches a resistor across the bus upon command from the IPC board. Red indicating lamps located on the bus discharge board and the signal conditioning boards indicate the presence of voltage (greater than 30 volts) across the bus.

d) Inverter and Output Filter Section

The inverter section consists of three pairs of high power IGBTs (6 total) connected in a 3-phase array; each pair consists of two IGBT's in series across the bus forming one output phase of the three phase output. Each pair is ADVanced pulse width modulated to synthesize a low harmonic 400 hertz voltage line to line. This three phase pulse width modulated output is connected to an output filter that smoothes the output voltages by reducing the higher order switching harmonics. The result is three line to line 400 hertz voltages that contain less than 3% distortion. The output filter consists of three inductors, one in series with each output phase, and three banks of capacitors connected line to line (delta) across the output of the inductors. This junction is the output of the inverter. This 3-phase voltage is then applied to the primary of the output transformer, which steps down the voltage, and provides voltage isolation from the inverter section.

e) Converter Output

The output of the main transformer is connected to a 3-phase contactor that provides the connection point for the AC output cables.

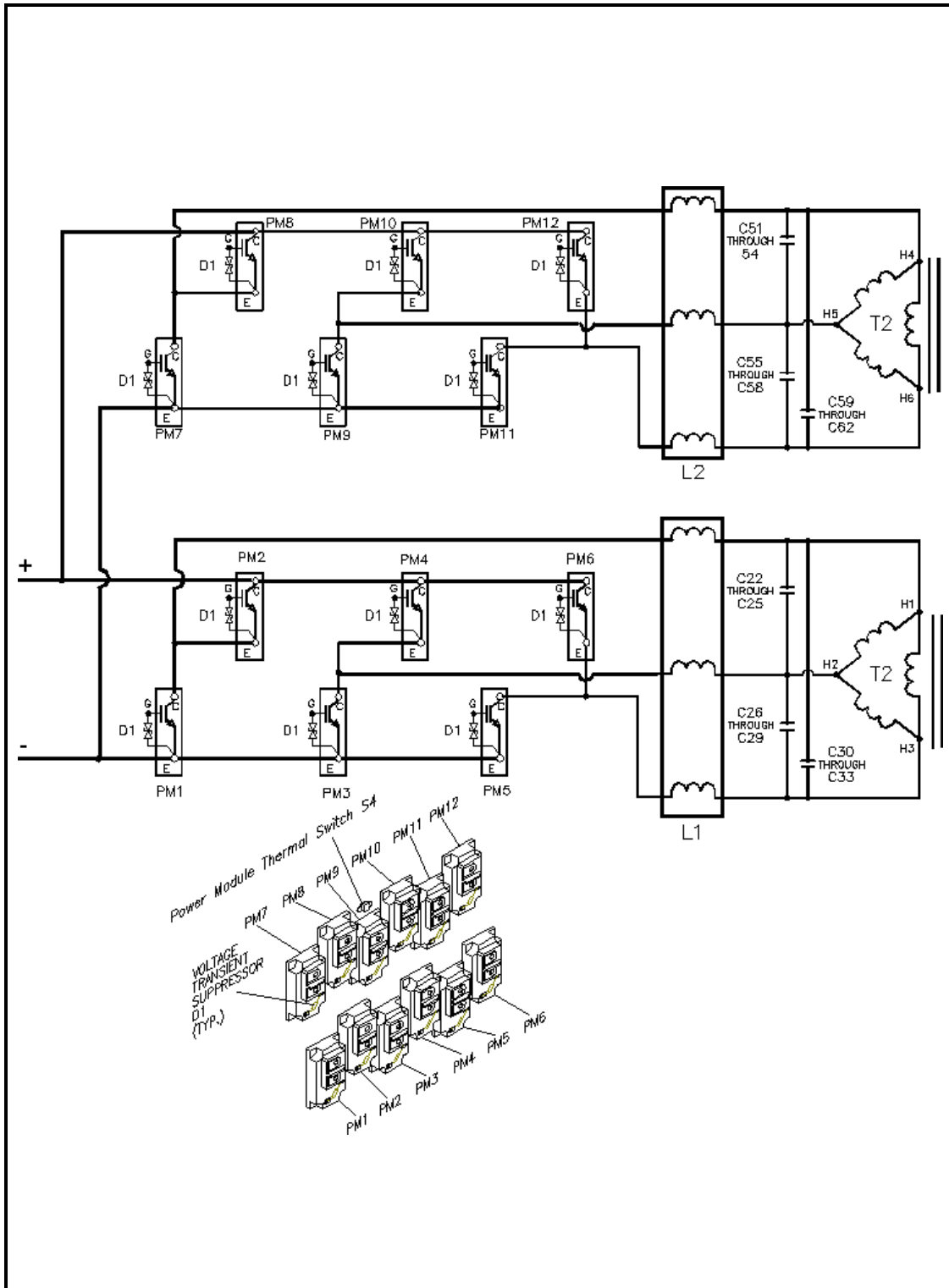

Inverter and Output Filter Section
Figure 7

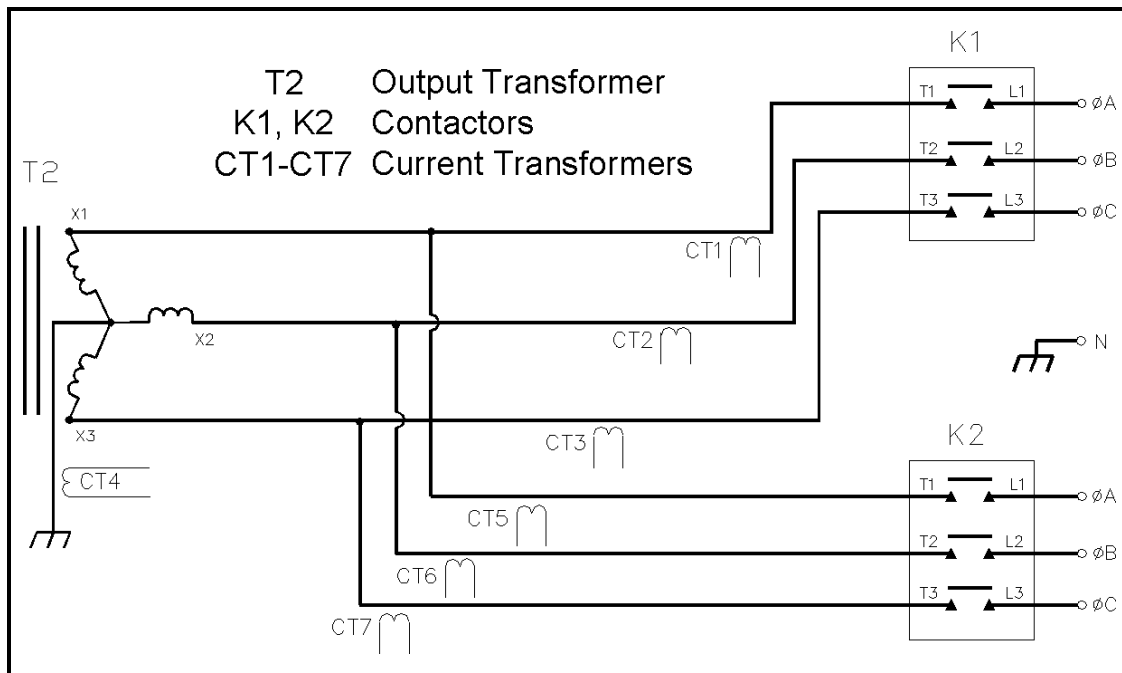

**Converter Output Circuit
 Figure 8**

f) 12 Pulse Input Filtering

The 12 Pulse Rectification System consists of a thyristor/diode assembly, 6 SCR modules, an input line reactor, a phase shifting input transformer, and two inter-phase transformers. The three-phase input voltage is applied to the input of the phase shifting input transformer through the input line reactor. Two new three-phase voltages, one shifted +15 degrees and one -15 degrees, relative to the input, are generated. Each three-phase voltage set is connected to a full wave rectifier bridge consisting of 6 SCR modules. The SCR modules are phase controlled only during start-up to limit in-rush current. Each rectifier bridge produces a +DC and -DC voltage that are paralleled through two inter-phase reactors, whose function is to force the two bridges to share the load current equally and allow for any differences in DC voltage produced by each bridge. The output of one inter-phase reactor is connected to the positive the other to the negative of the DC filter capacitors.

9) ADV Control System

The ADV Control System performs complete diagnostic testing upon each startup and continuous monitoring of all critical circuits and operating electrical values. Functions of the converter are selected through the control panel. Specifically, the control system performs the following:

- a) Checks all critical components prior to supplying 400 Hz AC.
- b) Monitors all critical operating parameters during operation.
- c) Signals a fault and indicates a potential problem if parameters approach critical levels during operation.
- d) Diagnoses and identifies the cause of a fault.

- e) Causes the converter to automatically shut down if factory-set output parameters or output characteristics fall outside safe operating limits.
- f) Measures power flow for billing purposes if desired. Stores history of up to 200 power cycles at the gate.
- g) Logs data into its own memory for downloading to an external computer through the control serial port.
- h) Provides an advanced and easy-to-use interface between the operator and the converter.

10) Event Records/Fault Monitoring

The Hobart PoWerMaster ADV control system performs complete diagnostic testing upon each startup and continuous monitoring of all critical circuits and operating electrical values. If the control system senses a problem with one of the circuits, or if one of the electrical values exceeds its safe operating limit, the control will generate and store an event record. Depending on the severity of the condition, the converter will either continue operation or will indicate a fault and shut the converter down. The two types of event records are warnings and faults.

- a) Warnings result when a problem is detected which does not interfere with the operation of the converter. The warning will be displayed on the front panel and the machine will continue to operate normally. An event record will be recorded.
- b) Faults occur when any of the fault limits are exceeded, when an internal problem occurs, or under certain conditions that would cause injury to personnel or damage to an aircraft or the converter. These limits are preset at the factory. A fault indication signifies a condition severe enough to discontinue all output power and shut the converter down. After the recognition of a fault the control system will immediately shut down, the red fault lamp will illuminate and the appropriate fault message will appear in the display. An event record will be stored to troubleshoot the problem.

See the Chapter 2 for troubleshooting and a list of faults, their possible causes, and corrective actions.

11) Detailed Description of Converter Components

- a) Control Panel (See Figure 9)

The function of each of the controls and indicators are as follows:

- (1) 400 Hz POWER ON push button

Pressing this push button will power the converter only, but will NOT close output contactor(s) to provide output power to the aircraft.

- (2) AC Output voltage adjustment push button

To adjust the output voltage, depress and hold the AC output voltage adjustment push button and the proper up or down arrow key.

Note: This adjustment can be disabled if the keypad disable switch, located behind the control panel, is in the "disable" position (see Section 3 in this Chapter).

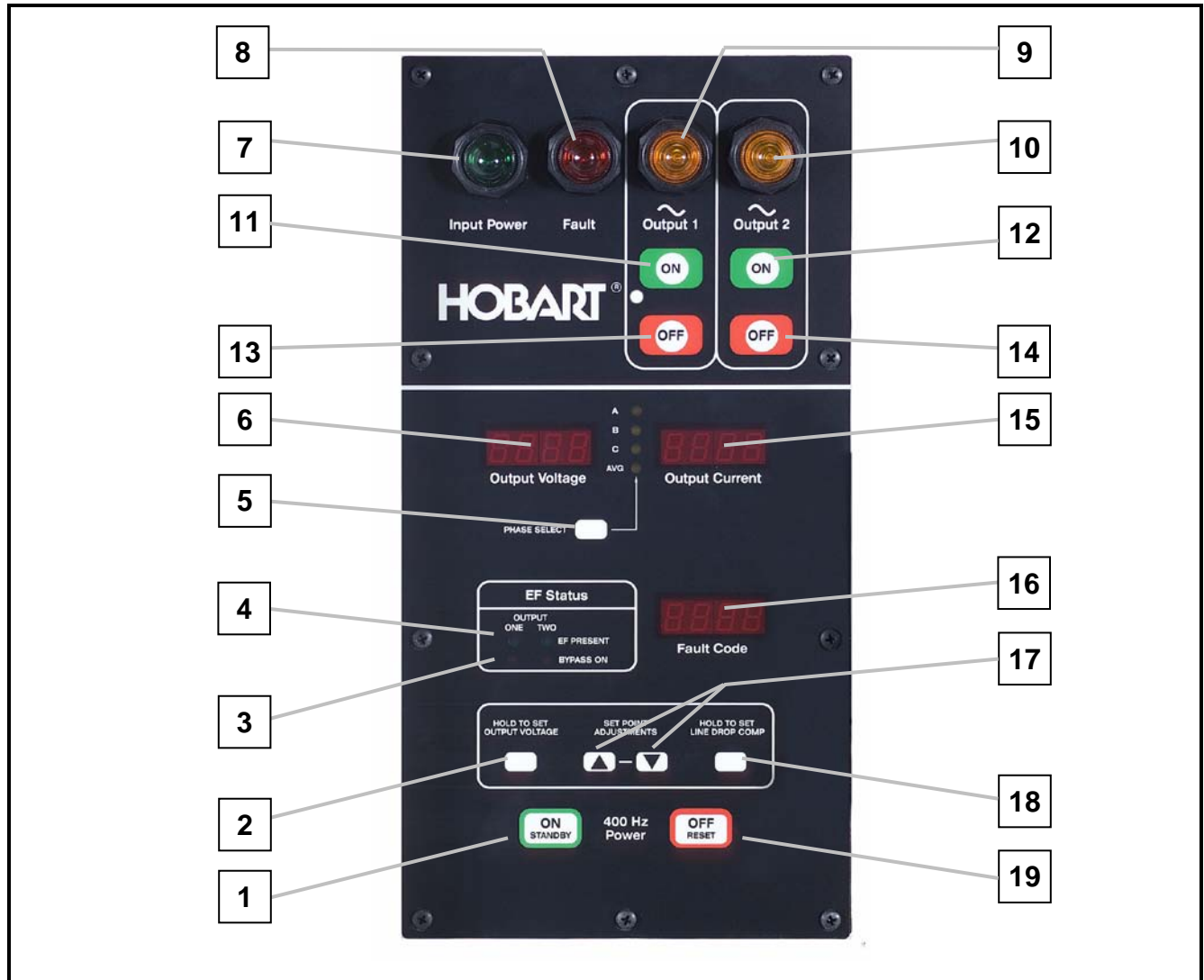

- | | |
|--|---|
| 1. 400 Hz Power On Push Button | 11. Output 1 On Push Button |
| 2. Output Voltage Adjustment Push Button | 12. Output 2 On Push Button |
| 3. Bypass On Lamp | 13. Output 1 Off Push Button |
| 4. EF Present Lamp | 14. Output 2 Off Push Button |
| 5. Phase Select Push Button | 15. Output Current Display |
| 6. Output Voltage Display | 16. Fault Code Display |
| 7. Input Power Lamp | 17. Set Point Up And Down Adjustment Push Buttons |
| 8. Fault Lamp | 18. Line Drop Compensation Adjustment Push Button |
| 9. Output 1 Lamp | 19. 400 Hz Power Off Push Button |
| 10. Output 2 Lamp | |

**Control Panel
 Figure 9**

(3) "EF" Bypass On lamp

The lamps indicate if EF is present on placed in bypass. Once the EF bypass is activated, the need for a returned EF signal from the aircraft is disabled, therefore allowing 400 Hz power to be sent uncontested to the output cables(s). Because "Live" unattended output cables are possible, the EF bypass is to be used for aircraft not equipped with EF circuitry or maintenance use only. If the aircraft or load has EF capability and the ADV detects the signal, the ADV will automatically disable the EF bypass mode and indicate that EF is present.

CAUTION

DO NOT use the EF bypass unless the output cables are connected to an aircraft or an approved load bank.

(4) EF present lamp

The presence of the EF signal(s) returning to the converter is displayed with illumination of one or both of the EF Present lamps in the EF status box.

(5) Phase select push button

With each press of this push button the A, B, C, or AVG lamp will light. The output voltage display and the output current display will show the real time value of the phase selected or the average of the group.

(6) Output voltage display

It displays the output voltage value at the output connection of the converter.

(7) Input power lamp

The green input power lamp indicates the presence of input power. The input power lamp flashes during converter self test.

(8) Fault lamp

The red fault lamp indicates that a fault is detected by the control system.

(9) Output 1 lamp

The amber output 1 lamp indicates the presence of power at the output 1 terminal of the converter.

(10) Output 2 lamp

The amber output 2 lamp indicates the presence of power at the output 2 terminal of the converter.

(11) Output 1 On push button

Depressing this push button will deliver 400 Hz power to the corresponding contactor.

(12) Output 2 On push button

Depressing this push button will deliver 400 Hz power to the corresponding contactor.

(13) Output 1 Off push button

Depressing this push button will cancel 400 Hz power to the corresponding contactor.

(14) Output 2 Off push button

Depressing this push button will cancel 400 Hz power to the corresponding contactor.

(15) Output current display

It displays the output current at the output connection of the converter.

(16) Fault code display

When a fault is detected by the control system, the fault code is displayed to assist with troubleshooting the problem. See Chapter 2 for a complete list of warning and fault codes.

(17) Set point up and down adjustment push buttons

These UP and DOWN push buttons increase or decrease the output voltage or the line drop compensation values. Simply press one of these push buttons while simultaneously pressing either the output voltage or line drop compensation push buttons.

(18) Line drop compensation adjustments push button

To adjust the line drop compensation value, depress and hold the line drop compensation adjustment push button while simultaneously pressing a set point up and down adjustment push button. The line drop compensation value, in percentage, will be shown in the fault code display.

(19) 400 Hz OFF push button

Pressing this push button opens all output contactor(s) and turns the converter off. If a fault condition is present, pressing this button will clear the fault and initiate converter self-test.

CAUTION

When the 400 Hz has been turned OFF, input power is still present in the converter.

b) Printed Circuit Boards (See Figure 10)

The units have seven (7) printed circuit (PC) boards in various locations inside the converter. The functions of each printed circuit board are as follows.

(1) Modulator PC Board A3 (MOD)

The Modulator PC board generates the pulse-width-modulated switching patterns that produce the output voltage sine wave. It has circuitry to produce a stable output voltage, voltage ramp-up and ramp-down, soft start, no break power transfer NBPT, active transistor diagnostics, output voltage/output current monitoring, and fault detection.

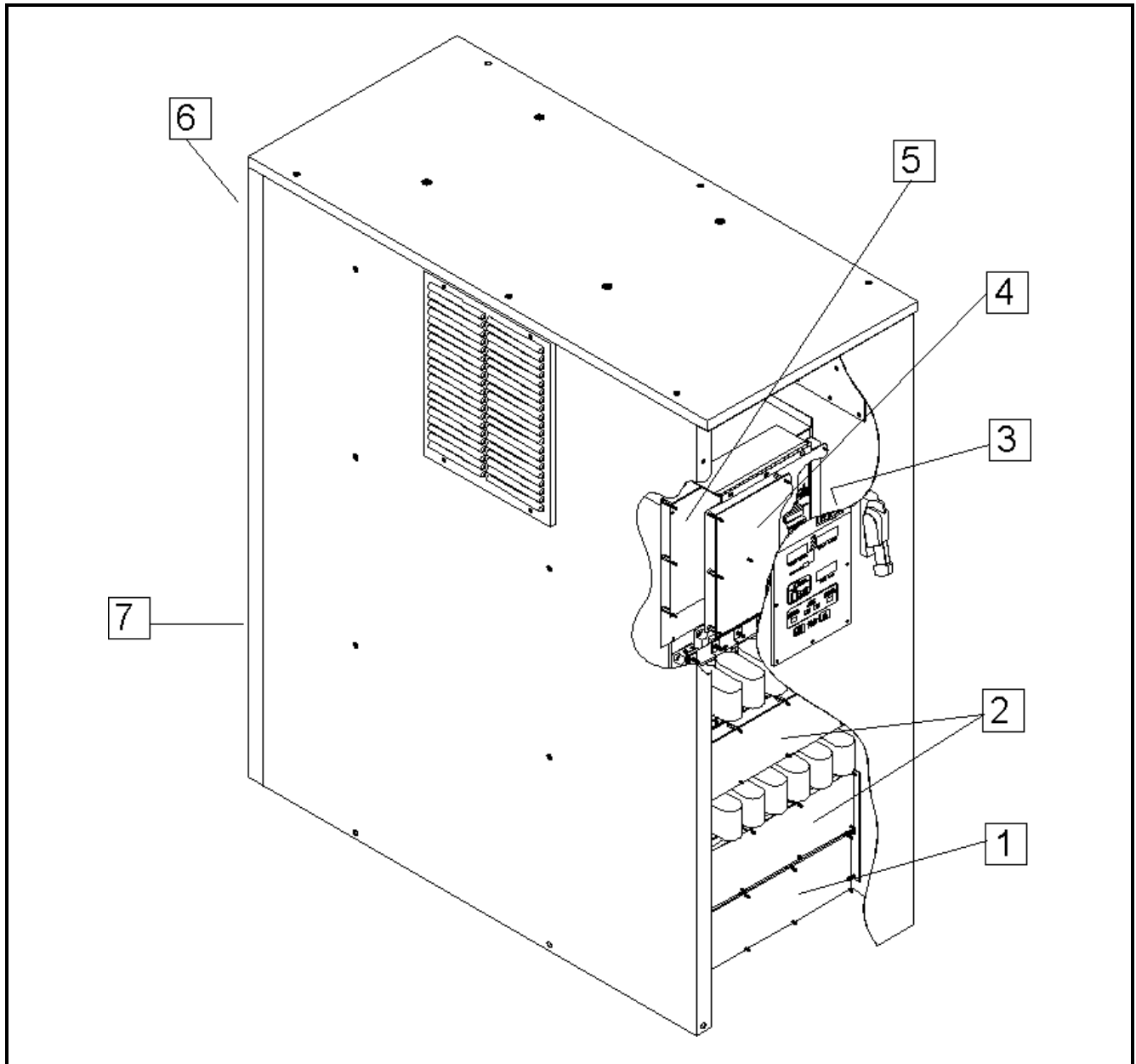

- | | |
|--|--------------------------------------|
| 1. Modulator PC Board (A3) | 5. Input Power Control PC Board (A4) |
| 2. Driver PC Boards (A5 & A10) | 6. Input/Output PC Board (A1) |
| 3. Control PC Board (A2) (not shown, behind control panel) | 7. Bus Discharge PC Board (A7) |
| 4. Signal Conditioning PC Board (A6) | |

Printed Circuit Board Locations
Figure 10

(2) Driver PC Board A5s & A10 (DRV)

The two driver PC boards translate the input drive signals from the modulator board into optically isolated drive signals for each of the 12 IGBT power modules.

(3) Control Board A2 (CTL)

The Control PC Board serves as the primary user interface displaying voltage, current, fault, and EF data. It has circuitry to monitor and tests critical circuits in the converter prior to and during operation. This PC board also has circuitry to provide system diagnostics, output voltage and current monitoring, run time and diagnostic data storage, and external serial data communications.

(4) Signal Conditioning Board A6 (SCB)

The Signal Conditioning PC Board senses and converts signals to low-level DC values for use by the Control PC Board, Input Power Control PC Board, and Modulator PC Board. The signals sensed are neutral current, output current, output voltage, DC Bus voltage, main transformer I.D. resistor, and transformer temperature sensor. In addition, the following signals are generated: average current, average power, average voltage. Each of these circuits is digitally adjustable.

(5) Input Power Control Board A4 (IPC)

The Input Power Control PC Board monitors the AC input voltage, AC input frequency, and power supply voltages within the converter. It provides drive signals for the thyristor/rectifier modules and the Bus Discharge PC Board. The IPC Board has circuitry to produce a stable DC bus voltage, soft start, self-diagnostics, fault detection, and door interlock monitoring.

(6) Input/Output Board A1 (IOB)

The Input/Output PC Board serves as the converter interface to the outside world. It processes the EF, interlock, bridge, and operator remote pendent signals to and from the converter.

(7) Bus Discharge PC Board A7 (BDC)

The Bus Discharge PC Board discharges the main DC bus at a controlled rate on command from the Input Power Control PC Board.

c) Components Inside Front Door (See Figure 11)

(1) Circuit Breaker (CB1)

The input power lines are wired into a circuit breaker. The external circuit breaker lever that operates the breaker switch utilizes a cable that pushes the breaker switch up (on) or down (off).

(2) Voltage Suppressers (RV1, RV2, RV3)

These three voltage suppressers are designed to help protect against input voltage spikes on the AC input lines, which could be lightning induced.

(3) Fuse (F3)

This fuse protects the control transformer secondary circuit. Its size and rating is FNQ 2A, 125-V.

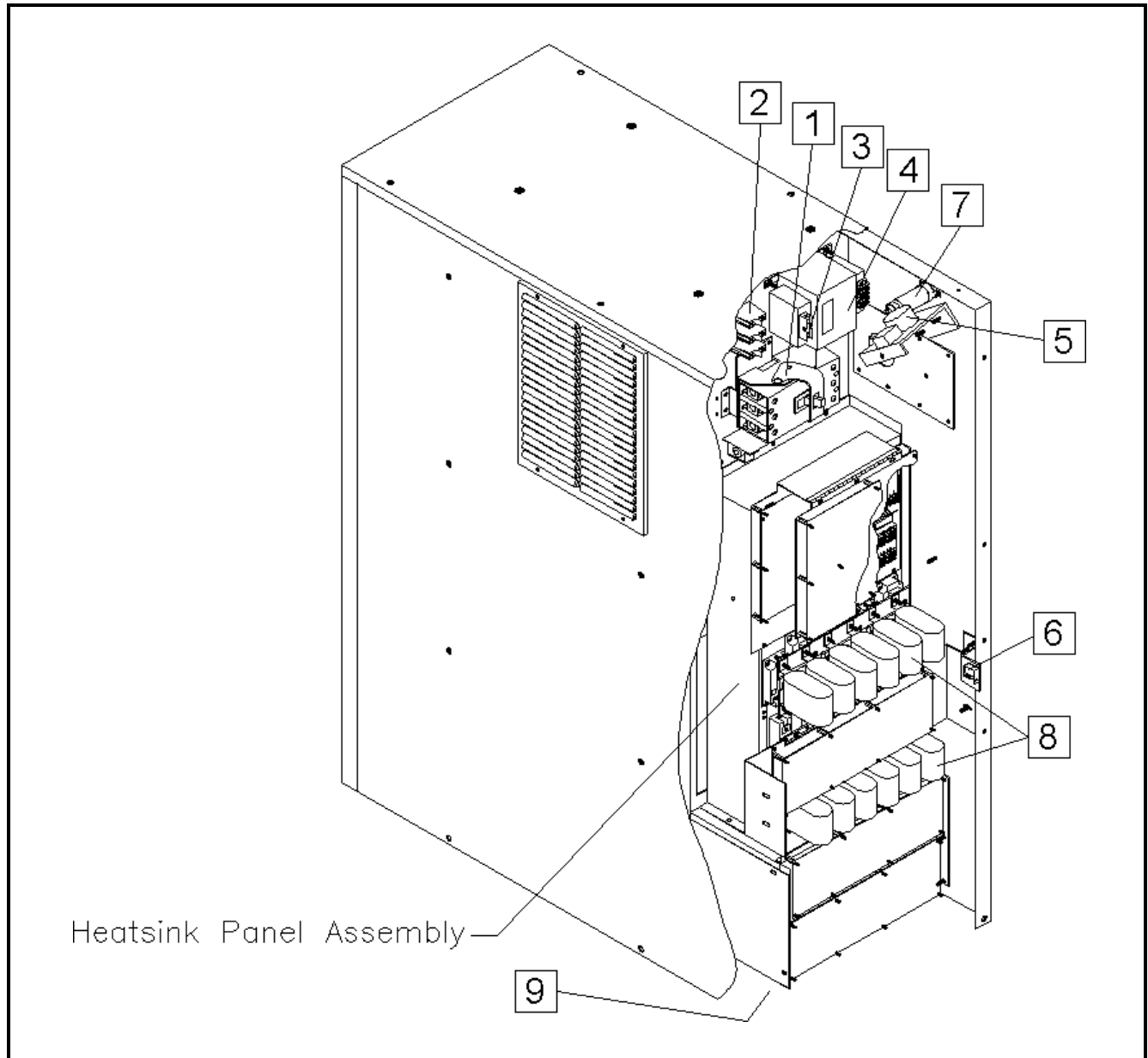

- | | |
|--|---|
| 1. Circuit Breaker (CB1) | 6. Door Interlock Switch (S7) |
| 2. Voltage suppressors (RV1, RV2, RV3) | 7. 115V AC Power Supply Hold-Up Capacitor (C42) |
| 3. Fuse (F3) | 8. DC Bus Capacitor Bank (C1-C12) |
| 4. Input/Control Transformer (T1) | 9. Air Filter |
| 5. Hour meter (M1) | |

Components Inside the Front Door
Figure 11

(4) Input/Control Transformer (T1)

This transformer steps the input voltage down to 115-V AC for operation of the converter's control circuits and other circuits requiring this voltage.

(5) Hour meter (M3)

This component monitors the amount of time 400 Hz power is generated in hours.

(6) Door Interlock Switch (S7)

The switch immediately shuts down the converter's 400 Hz supply when the door is opened. The door interlock can be bypassed for maintenance purposes only. See Section 2-2, Figure 1, to bypass switch.

(7) 115V AC Power Supply Hold-Up Capacitor (C42)

This capacitor enables the converter to withstand a 50 millisecond power interruption (micro break). The capacitor will discharge into the power supply circuitry to maintain power to the control system.

(8) DC Bus Capacitor Bank (C1-C6)

The DC capacitor bank, along with the input filter reactors and a number of other components, provide filtering of the rectified AC input voltage. The bank consists of twelve capacitors connected by an integrated bus system.

(9) Inlet Air Filter – Hobart replacement part number 283159-003

The air filters help provide clean air for circulation and maintain proper airflow.

CAUTION

To maintain a uniform air flow through the power module heat sink, the air filters **MUST** be in place at ALL TIMES during operation of the converter.

d) Heat Sink Panel Assembly Details (See Figure 12)**(1) IGBT (Insulated Gate Bipolar Transistor) Power Modules (PM1-PM12)**

The twelve IGBT power modules provide the actual switching which produces the output voltage sine wave from the filtered DC voltage, under control of the modulator and driver PC Boards.

(2) Power Module Thermal Switch (S4)

This switch is located on the heat sink assembly. The modulator PC board monitors the thermal switch to detect overheating.

(3) Voltage Surge Suppressors (RV6-RV7)

These suppressors are connected across the rectified input to protect the SCR-Diode Modules from voltage surges.

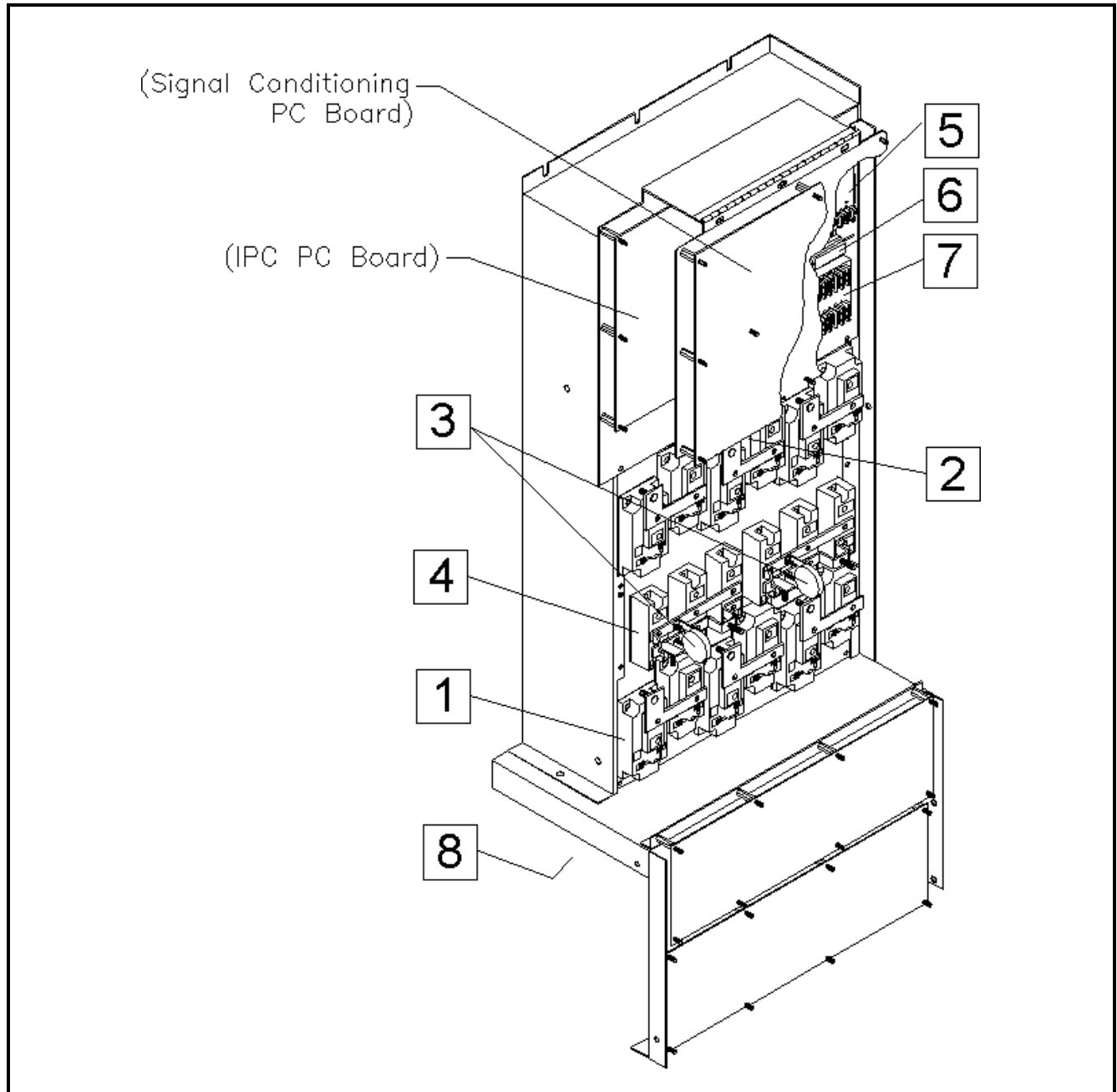

- | | |
|--|---------------------------------------|
| 1. IGBT (PM1-PM12) | 5. Input Step-down Power Supply (PS1) |
| 2. Power Module Thermal Switch (S4) | 6. Resistor, Power Supply Load (R1) |
| 3. Voltage Surge Suppressors (RV6-RV7) | 7. Control Logic Power Supply (PS2) |
| 4. SCR-Diode Modules (SCR1-SCR6) | 8. Heat Sink |

Heat Sink Panel Assembly
Figure 12

(4) SCR-Diode Rectifier Modules (SCR1-SCR6)

These modules are used as a soft start mechanism. They limit the inrush current to control the start up of the machine.

(5) Input Step-Down Power Supply (PS1)

This switching type power supply draws 115V AC from the input /control transformer and converts it to +12V DC. The output is directed to the control logic power supply.

(6) Power Supply Load Resistor (R1)

The resistor provides a constant “pre-load” on the input step-down and control logic power supplies.

(7) Control Logic Power Supply (PS2)

The 12 VDC input from the step down power supply is fed into the control logic power supply in order to achieve a combined ± 12 and +5 VDC output. These three outputs feed the Input Power Control PC Board, which distributes power to the other PC Boards.

(8) Heat Sink

The heat sink provides cooling for the power components on the heat sink panel assembly.

e) Components Inside Rear Door (See Figure 13)

(1) Output Contactors (K1 and K2)

Each contactor is a sealed unit, which contains a magnetic operating coil and four sets of contacts. The three larger contacts conduct 3-phase AC voltage output. The Input/Output PC Board monitors the smaller, fourth set of contacts to verify proper operation of the contactors.

(2) Output Current Sensing Transformers (CT1-CT7)

The cables, which conduct output power to each output contactor, pass through a set of current transformers. These current transformers monitor the output load current in each of the three output phases, detect the magnitude of current flowing from the converter to its load, and supply a reduced value current signal to the Signal Conditioning PC board. The Neutral Line Current Sensing Transformer CT4 is used to detect excessive current through the neutral line, and continually sends a signal to the Signal Conditioning PC board.

(3) Fan Motor Start Capacitors (C13 & C43)

These components limit the inrush of current to the fan motors upon start up.

(4) Terminal Blocks (TB4 & TB7)

Provides connection points for the cooling fans and the fan motor start capacitors with power coming from the Input/Output PC Board

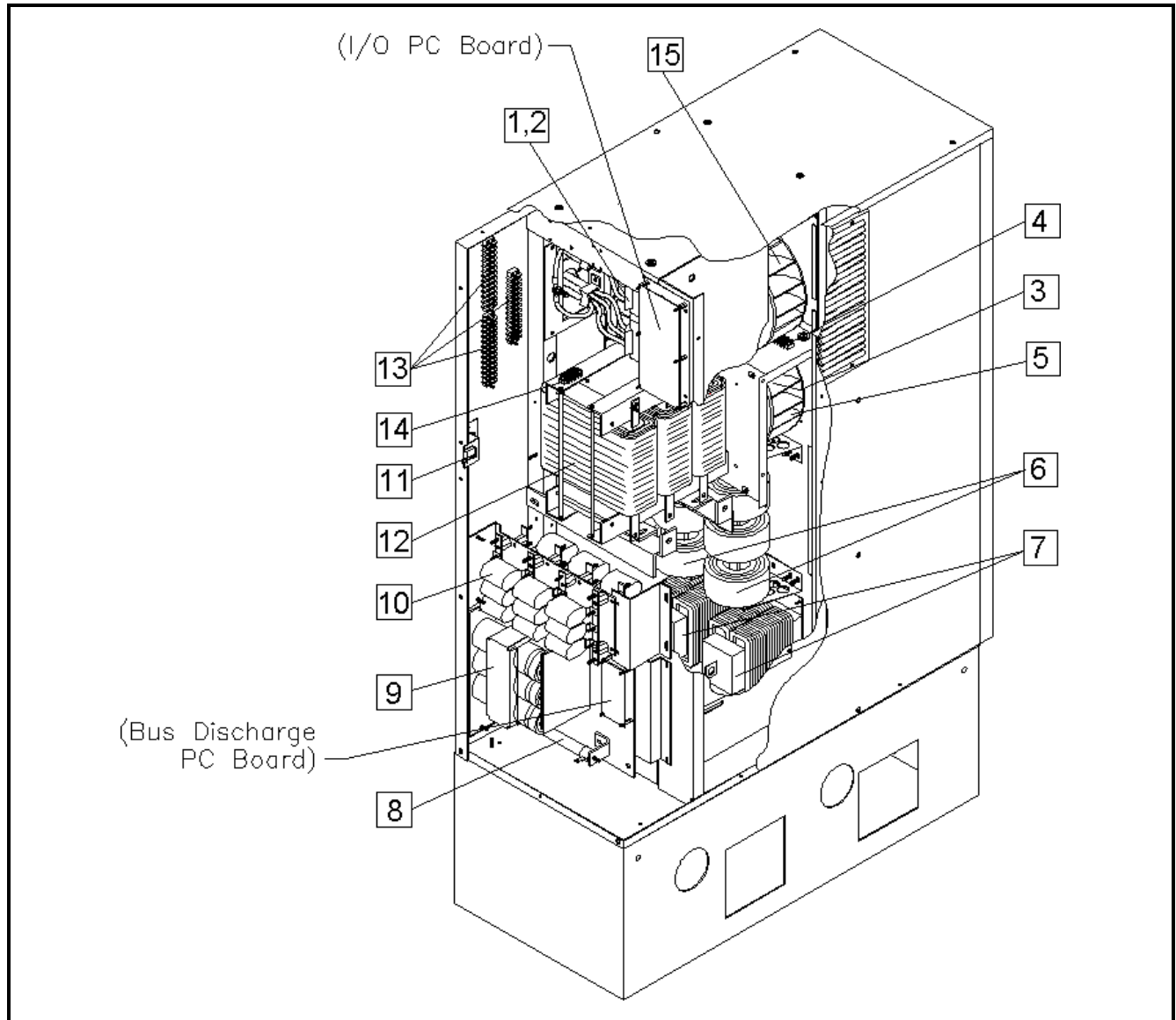

- | | |
|--|--|
| 1. Output Contactors (K1 and K2) | 8. DC Bus Discharge Resistor (R3) |
| 2. Output Current (CT1-CT7) and Neutral Sensing (CT4) Transformers | 9. Electrolytic DC Capacitors (C14-C19) |
| 3. Fan Motor Start Capacitors (C1 & C43) | 10. AC Filter Capacitors (C22-C33 & C51-C62) |
| 4. Fan Terminal Blocks (TB4 & TB7) | 11. Door Interlock Switch (S2) |
| 5. Cooling Fan (B1) | 12. Output/Main Transformer (T2) |
| 6. Three Phase AC Filter Inductors (L1-L3) | 13. 12 Station Terminal Strips (TB1-TB3) |
| 7. DC Filter Inductors (L4-L5) | 14. Terminal Strip (TB5) |
| | 15. Cooling Fan (B2) |

Components Inside the Rear Door
Figure 13

(5) Cooling Fan (B1)

The fan circulates cooling air through the converter. Air enters the unit through louvers, flows through the heat sink assembly, through the magnetic compartment and leaves through the louvers next to the output cables.

(6) Three Phase AC Filter Inductors (L1-L3)

These inductors, in conjunction with the AC filter capacitors, act as a filter for the pulse width modulated voltage produced by the inverter.

(7) DC Filter Inductors (L4-L5)

The inductors work with the electrolytic DC capacitors to smooth the DC current leaving the SCR modules.

(8) DC Bus Discharge Resistor (R3)

The resistor works in conjunction with the Bus Discharge PC Board, to completely drain the electrolytic DC capacitors in less than 3 seconds. The instances that trigger this immediate discharge are:

- a Opening either canopy door during when powered ON
- b Fault occurrences
- c Removal of converter input power

(9) Electrolytic DC Capacitors (C14-C19)

The capacitors work in conjunction with the DC filter inductors to filter the DC voltage from the SCR modules.

(10) AC Filter Capacitors (C22-C33 & C51-C62)

The AC capacitor bank and the 3-phase AC filter inductors provide filtering of the pulse-width-modulated voltage provided by the inverter.

(11) Door Interlock Switch (S2)

The converter cannot be turned on unless both doors are closed securely and will shut down immediately upon opening either door.

(12) Output/Main Transformer (T2)

The output transformer transforms the output from the inverter section into the desired 115/200 VAC output voltage.

(13) 12-Station Terminal Strips (TB1-TB3)

The three station terminal strips connect the ADV to the outside world using remote controls, bridge interlock circuitry, EF circuitry and other external connections.

(14) Terminal Strip (TB5)

- a Connection point for the transformer temperature sensor.
- b Connects the unit identification resistor. There is a unique resistor for each converter configuration.

(15) Cooling Fan (B2)

The fan circulates cooling air through the converter. Air enters the unit through louvers, flows through the heat sink assembly, through the magnetic compartment and leaves through the louvers next to the output cables.

Section 2 Preparation for Use, Storage or Shipping

1) Receipt and Inspection of Equipment

The converter has been thoroughly inspected and tested at the factory and prepared for shipment in accordance with standard industrial practices for safe shipment. Upon receiving this equipment, inspect it as follows.

- a) Visually inspect the shipping crate for damage. If any damage is detected, request that the carrier agent inspect the shipment and note the damage on the delivery receipt. This is for your protection.
- b) If there is no obvious damage to the shipping crate, unpack the unit as follows:

2) Unpacking the Unit

- a) Remove crate, leaving unit on pallet for lifting it into place for mounting. Take care to avoid damage to the equipment if bars, hammers, etc. are used in unpacking. Remove all unused hardware from the unit.
- b) Visually inspect the unit for evidence of external damage such as damaged sheet metal, scratches, dents, etc. Check also for loose connections and components. If the equipment has been damaged in transit, file a claim for damage at once. If you require assistance with a damage claim, furnish Hobart Ground Power with full information about the claim.

NOTE: Save the shipping container until the unit has been put into service and determined to be operating correctly.

3) Input Cable Size and Temperature Requirements

Figure 1 shows input cable size and temperature requirements for converter units covered by this manual. This information is from the U.S. National Electrical Code ANSI/NFPA 70. Install this equipment per the latest edition, available from the National Fire Protection Association, 470 Atlantic Avenue, Boston, MA 02210.

Input Voltage	120 kVA
380 V	161 Amperes 1/0 AWG (53 mm ²)
460 V	133 Amperes 1 AWG (42 mm ²)

Values given in this chart assume that **90° C rated copper cables** will be used, with typical wire sizing per chart 310-16 of the 1999 National Electrical Code. Wire sizes should be verified by a qualified electrician and should conform to local electrical codes. This chart assumes operation at 50° C ambient temperature. Total input cable weight is limited to 250-lbs (113.4 kg) on trailer mounted converters.

Input Cable Size Requirements - Cables Rated at 90° C
Figure 1A

Input Voltage	120 kVA
380 V	161 Amperes 2/0 AWG (68 mm ²)
460 V	133 Amperes 1/0 AWG (53 mm ²)

Values given in this chart assume that **75° C rated copper cables** will be used, with typical wire sizing per chart 310-16 of the 2008 National Electrical Code. Wire sizes should be verified by a qualified electrician and should conform to local electrical codes. This chart assumes operation at 50° C ambient temperature. Total input cable weight is limited to 250-lbs (113.4 kg) on trailer mounted converters.

Input Cable Size Requirements - Cables Rated at 75° C
Figure 1B

4) Installation

A Hobart converter requires no additional preparation in order to supply power to an aircraft. It needs only to have its input cable(s) connected to an appropriate source of power and its output cable(s) connected to an aircraft. Proceed as follows for putting the converter unit into service.

WARNING

The method of installation, conductor size, and over-current protection shall conform to the requirements of the local electrical code, the national electrical code, or other national codes, as applicable. Qualified persons shall do all installation wiring and machine reconnection.

a) Cable Entry Locations

Input and output cable entrance shall be made through the cable entrance holes provided in the converter cabinet. Consult our Service Department if problems arise.

b) Install Input Cables at Power Supply Service

Before connecting input cables to the power supply service, check voltage, amperage and phase ratings of the service. Make certain that the capacity of the service is adequate for the power requirements of the unit being connected to it. Make certain that the service used, as the source of input power, is grounded. Refer and conform to your local electrical code when selecting and installing power supply service.

Make sure electrical service is off. Connect the input power cables to the input power source, and connect the grounding conductor to a proper ground.

c) Install Input Cables into Converter Circuit Breaker

(1) Make sure electrical service is off.

(2) Open the front door of the unit by turning all three latches counterclockwise with an 8 mm Allen wrench

- (3) Route the cable up through the hole in the base and then through the cable clamp located below the circuit breaker (CB1).
- (4) Using a 3/8 inch Allen wrench, connect input cable leads securely to terminals L1, L2, and L3 on circuit breaker.
- (5) Using a 5/16 inch Allen wrench, connect the ground wire securely to the ground lug located below the circuit breaker.

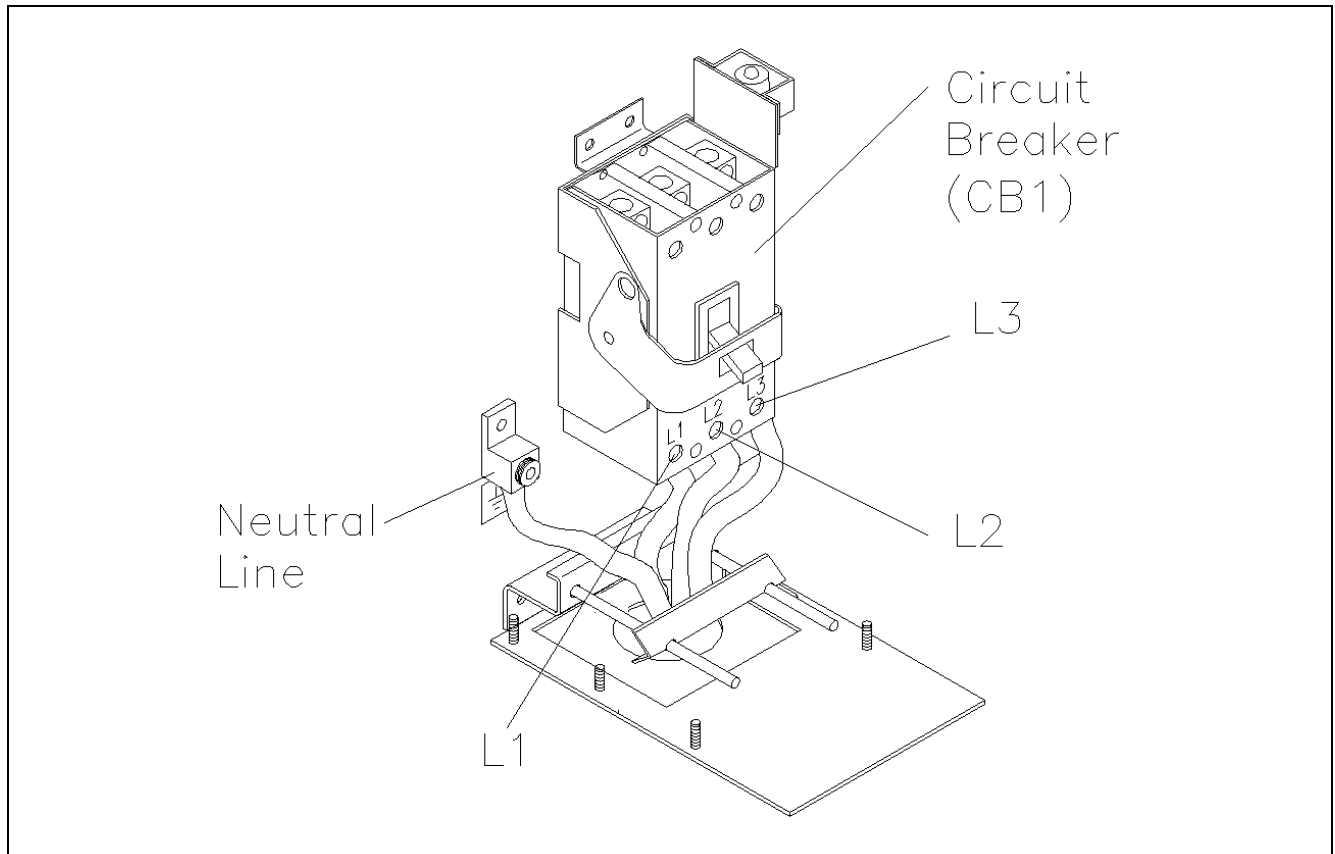

Input Cable Connections
Figure 2

- (6) Pull the excess cable downward through the clamp in the base, and tighten the clamp around the cables. Leave just enough slack in the cables so there is no strain on them. Avoid damage to cable insulation.
- (7) Close and latch the front door of the unit.

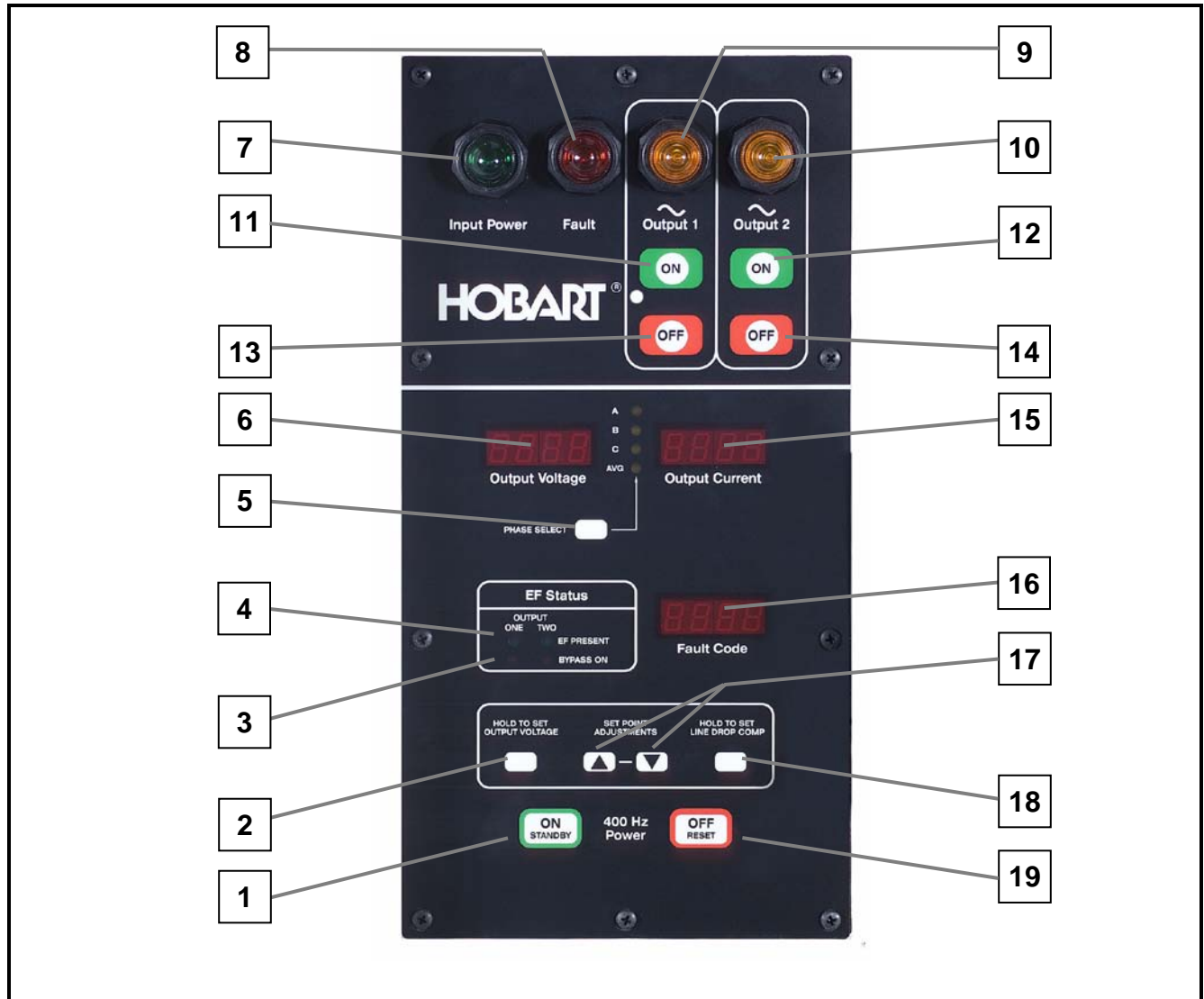

- | | |
|--|---|
| 1. 400 Hz Power On Push Button | 11. Output 1 On Push Button |
| 2. Output Voltage Adjustment Push Button | 12. Output 2 On Push Button (if applicable) |
| 3. Bypass On Lamp | 13. Output 1 Off Push Button |
| 4. EF Present Lamp | 14. Output 2 Off Push Button (if applicable) |
| 5. Phase Select Push Button | 15. Output Current Display |
| 6. Output Voltage Display | 16. Fault Code Display |
| 7. Input Power Lamp | 17. Set Point Up And Down Adjustment Push Buttons |
| 8. Fault Lamp | 18. Line Drop Compensation Adjustment Push Button |
| 9. Output 1 Lamp | 19. 400 Hz Power Off Push Button |
| 10. Output 2 Lamp (if applicable) | |

Control Panel
Figure 3

d) Check Converter No-Load Operation

A no-load check should be made before the output cables are connected to the converter. Proceed as follows.

- (1) Make certain that both converter doors are tightly closed and latched.
- (2) Apply input power to the converter from the input power source; throw circuit breaker handle, on the converter, to ON position. The green INPUT POWER lamp will flash for several seconds and then stay illuminated.
- (3) Press the 400 Hz POWER ON push button. At this time the unit output voltage is displayed on the control panel.
- (4) Press the control panel 400 Hz POWER OFF push button. The INPUT POWER lamp will remain illuminated.
- (5) Check optional remote START/STOP controls and bridge interlock feature for proper operation.
- (6) Shut off power at the input power source. The INPUT POWER lamp will shut off.

e) Install Output Cable and Remote Controls Panel, if applicable

Each output cable and remote control panel cable enters the converter through a cable clamp in the bottom panel. These cables connect directly to the terminals of the output contactor and to the appropriate terminals on the 12-station terminal strips located on the base of the converter inside the rear door. Use the terminal strips for the 28 VDC interlocks (EF signals) and the remote control lines.

NOTE: To determine the appropriate output cable size, consult your local electrical code. For most applications, an industry standard aircraft cable is recommended. Use No. 12 AWG for the interlock signal (E and F terminals) wires. The output cable leads (A, B, C, N) should be equipped with terminals suited for a 3/8" diameter terminal stud. The Interlock signal (E and F) and remote control leads should be equipped with terminals suited for a 5/16" diameter terminal stud.

NOTE: If the output cable is installed in conduit, the conduit must be non-ferromagnetic, such as aluminum.

- (1) Open the rear door of the unit by turning all three latches counterclockwise with an 8 mm Allen wrench.
- (2) Loosen the cable clamp screws at the cable horn that is mounted in the bottom panel.
- (3) Route the output cables, or remote control cables (if applicable), through the cable horn and clamp. Pull enough of the cables through to allow working space.
- (4) The output contactor can be seen inside the rear door on the far left. An identification label identifies each terminal stud on the contactor. A band-type marker should identify each cable. Connect cable lead "A" to terminal marked "A", "B" to terminal "B", and "C" to terminal "C" on the appropriate contactor. Tighten terminal nuts securely.

WARNING

Turning wrench or socket sizes that do not fit securely may cause personal injury. Damage to hardware may also occur.

- (5) Three 12-station terminal strips are located just inside the rear door of the unit in front of the output contactors. Connect interlock leads “E” and/or “F” to the terminal marked “EF” for the corresponding output connected in the previous step.
- (6) At the rear of the unit, connect the remote control leads to the terminals for each corresponding output.
- (7) Pull the excess cable out through the clamp assembly and out of the unit, tighten the clamp around the cables. Leave just enough slack in the cables so that there is no strain on them. Avoid damage to cable insulation.
- (8) Close and latch the rear door of the unit.
- (9) The converter is now ready for service. See Section 3 of this Chapter for operating instructions.

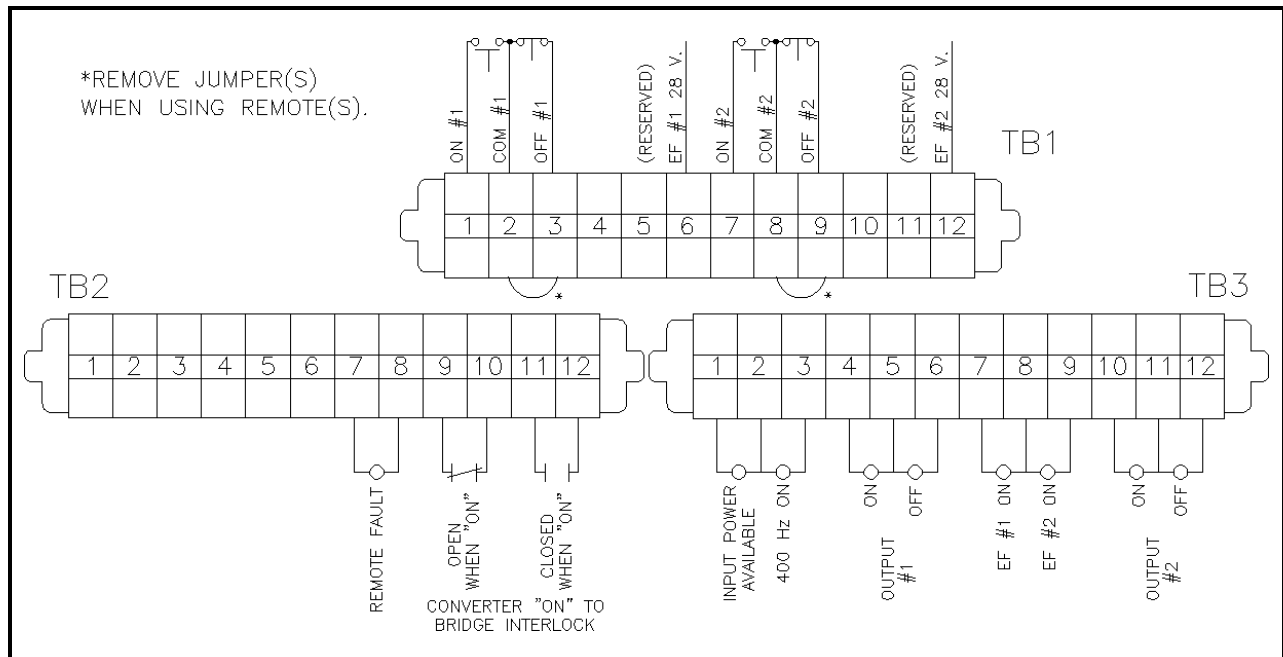

EF Signal and Remote START/STOP Control Connections
Figure 4

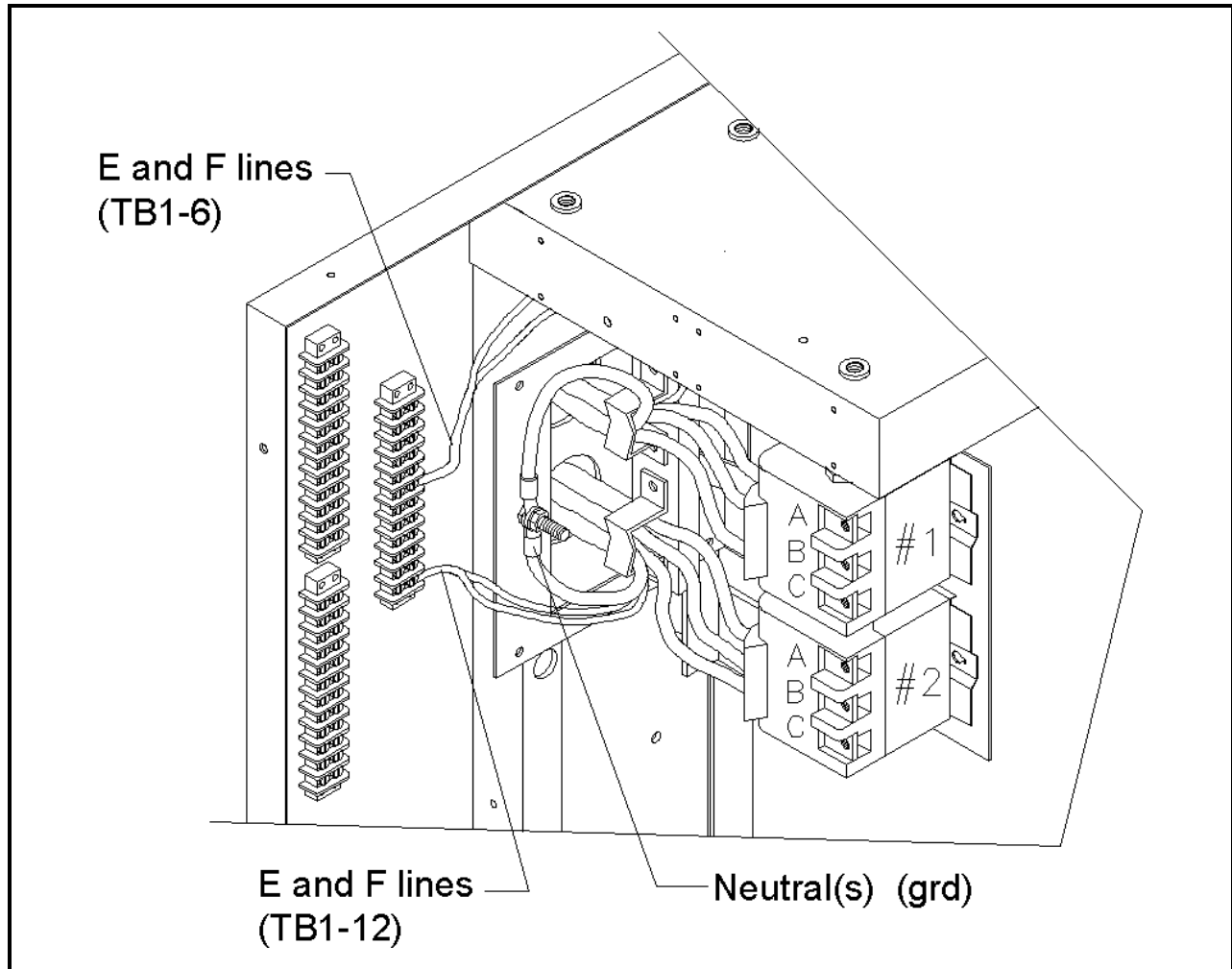

Output Contactor Connection
Figure 5

5) Preparation for Storage

a) General

- (1) The unit should be prepared for storage before installation, or as soon as possible, after being removed from service.
- (2) The unit should be stored in a building which is dry and which may be heated during winter months.
- (3) Moisture absorbing chemicals are available for use where excessive dampness is a problem. However, the unit must be completely packaged and sealed if moisture absorbing chemicals are to be effective.

b) Temporary Storage

When storing the unit for 30 days or less, prepare as follows:

- (1) Use moisture absorbing chemicals where excessive dampness is a problem. The unit must be completely packaged and sealed if moisture absorbing chemicals are to be effective. Seal all openings. Use a waterproof, vapor proof material that is strong enough to resist puncture damage from air pressures.
- (2) Store the unit in a building which is dry and which may be heated during winter months.

c) Long Term Storage

- (1) To protect the converter's components, the complete unit should be packaged, using moisture proof packaging and sealing material. Place containers of moisture absorbing chemicals, such as silica gel, in the unit before packaging.
- (2) Store the unit in a building which is dry and which may be heated during winter months.

6) Preparation for Shipment

During long shipments, vibration, jolting, etc may loosen the converter's retaining hardware. Check this hardware periodically during the shipment to make certain that retaining hardware is secure.

Section 3 Operation

IMPORTANT

Before attempting to operate the converter, read this entire section to become fully familiar with how the converter operates.
--

1) General

This section contains basic instructions for safe, efficient equipment operation. Operating instructions are presented in step-by-step sequence for supplying 400-Hz power to an aircraft.

2) 115 V AC, 400 Hz Operation

The following operating instructions explain basic converter operation from the control panel.

a) Pre-Start Up Inspection

- (1) Make certain that both converter doors are tightly closed. The unit is equipped with two door interlock switches. Opening either door will disable the unit. Therefore both doors must be closed to operate the unit. This feature is included for the safety of the user.
- (2) Make sure the air filter is in place (Hobart Ground Power Replacement Part No. 283159-003). The air filter helps provide clean air for circulation and uniform airflow through the power module heat sink. With a missing air filter, the air will flow unevenly through the heat sink causing the power modules to cool improperly. **The air filter MUST be in place at ALL TIMES during the operation of the converter.**

b) Startup Procedure

The following steps will turn the machine on so that output voltage can be checked without power delivery to an aircraft.

CAUTION

Use output cable(s) of proper size and length for the converter's power output rating.
--

- (1) Connect output cable plug connector(s) to aircraft receptacle(s). Be sure the connector(s) is mated fully and securely.
- (2) Raise circuit breaker handle beside the control panel to the ON position.
- (3) Apply input power to the converter from the input power source. The green INPUT POWER lamp, on the control panel, will flash for several seconds and then stay illuminated.
- (4) Press the 400 Hz POWER ON push button to turn the converter on without power delivery. 400 Hz power is now present within the machine. To turn the converter off, simply press the 400 Hz POWER OFF push button.

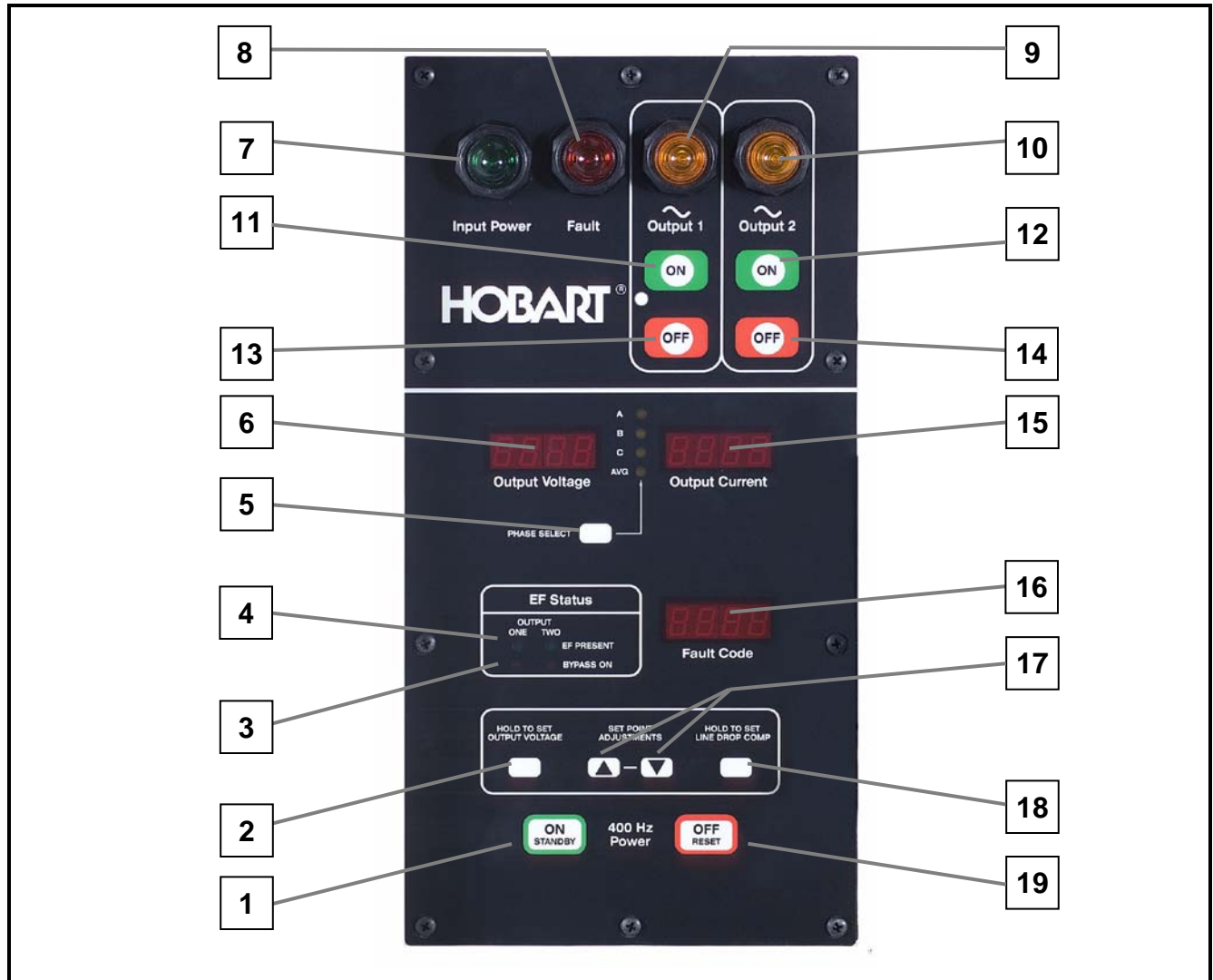

- | | |
|--|---|
| 1. 400 Hz Power On Push Button | 11. Output 1 On Push Button |
| 2. Output Voltage Adjustment Push Button | 12. Output 2 On Push Button (if applicable) |
| 3. Bypass On Lamp | 13. Output 1 Off Push Button |
| 4. EF Present Lamp | 14. Output 2 Off Push Button (if applicable) |
| 5. Phase Select Push Button | 15. Output Current Display |
| 6. Output Voltage Display | 16. Fault Code Display |
| 7. Input Power Lamp | 17. Set Point Up And Down Adjustment Push Buttons |
| 8. Fault Lamp | 18. Line Drop Compensation Adjustment Push Button |
| 9. Output 1 Lamp | 19. 400 Hz Power Off Push Button |
| 10. Output 2 Lamp (if applicable) | |

**Control Panel
 Figure 1**

- (5) The output voltage to be delivered to an aircraft must be checked the first time the converter is turned on. If it is necessary to change the factory set value, press and hold the "Set Output Voltage" push button while simultaneously pressing the appropriate up/or down push button until the output voltage display changes to the preferred voltage value. This new output voltage value need only be set once; the voltage level will remain the same for all future operations of the converter, even when the unit is turned off or disconnected from input power. It may, however, be changed as often as desired.

c) Immediate Output Power Delivery

400 Hz power will not be delivered to the aircraft until the output contactor(s) has been closed.

- (1) Apply input power to the converter from the input power source.
- (2) Raise circuit breaker handle beside the control panel to the ON position. The green INPUT POWER lamp on the control panel will flash for several seconds and then stay illuminated.
- (3) Press OUTPUT ON push button. The output lamp will be illuminated.

If the output cable from the converter is connected properly to an aircraft, an EF DC safety interlock signal will be sent back to the converter to allow the converter to operate as normal.

d) Line Drop Compensation Setting

Line drop compensation must be set the first time the converter is operated. Line drop compensation allows the converter to automatically compensate for the voltage drop caused by the resistance of long output cables.

When operating under no-load, the line drop compensation will be zero therefore the output voltage display will typically read 115 volts (a factory setting).

When operating the converter under a load, with line drop compensation present, the output voltage display will display the voltage at the output contactor. The value displayed will read higher than the no-load value because it is adding extra voltage to compensate for power lost through the output cables.

To check the line drop compensation percentage value, simply press the line drop compensation push button. The value given, which appears in the Fault Code display, will be the percentage of voltage over the normal 115 volts the converter is adding to the output contactors. From the contactors, the voltage gradually decreases through resistance over the length of the cable. As a result, the line drop in voltage will yield the desired value of 115 volts at the aircraft.

Once the line drop compensation is set, the value will remain the same for all future operations of the converter. Turning the unit off or disconnecting from input power will not affect the line drop compensation values. It may however be changed as often as desired.

To determine if the line drop compensation value should be changed, perform the following steps:

- (1) Turn on all available electrical devices on the aircraft. The aircraft should be drawing the maximum possible amount of current from the converter without exceeding the unit's maximum power rating.

- (2) Have an assistant measure the voltage being delivered to the aircraft through the No. 1 output at the aircraft end of the cable.
- (3) If the value measured above does not match the desired voltage value, press and hold the line drop compensation adjustment push button while simultaneously pressing the appropriate up or down adjustment push button on the control panel to change the line drop compensation value. Have the assistant report when the measured value matches the desired value.

e) Phase Select

Press the phase select push button to display the output voltage and current values of phase A, B, or C or to check the average of all three.

f) Operating Procedure

Since the converter is a solid-state unit, rather than a rotating, engine/generator type, the unit requires no intervention once it is running normally (i.e., no fuel, oil, etc. is needed). If the control system senses a problem, the fault light on the control panel will illuminate and activate the appropriate action automatically.

g) Discontinued Power Delivery

To discontinue power from either output, press the corresponding output off push button. The corresponding output lamp will no longer be illuminated.

WARNING

Never disconnect an output cable while output power is on. SHOCK HAZARDS EXIST!

If an output cable is inadvertently disconnected from the aircraft while the converter is operating, the converter will shut off under an EF warning.

On a multiple-output converter, if both cables are in use and if both the cables are inadvertently disconnected from the aircraft, the converter will shut off under an EF warning. However, if at least one cable remains connected to the aircraft, the converter will continue to operate and deliver power through the connected cable. This feature is included for the safety of the user and should never be used as an alternate method of discontinuing output power to an aircraft.

h) Shutdown Procedure

- (1) To stop power delivery to one the output and turning converter off, either press the control panel 400 Hz power off push button or press the remote control stop push buttons on the remote connected, if applicable. The output power lamp will no longer be illuminated.

WARNING

Never disconnect an output cable while output power is on.

- (2) Be sure 400 Hz power is not being delivered through an output cable.
- (3) Disconnect the output power delivery cable from the aircraft.

It is not necessary to discontinue input power between operations of the converter. When the unit is not delivering output power, it uses only a small amount of input power and may be left connected to input power indefinitely. If desired, shut off power at the input power source and the green input power lamp will no longer be illuminated.

i) Keypad Disable switch

Once the output voltage and line drop compensation values are set for the ADV, it is possible to lock both values to restrict changes by the operator from the control panel. The keypad disable toggle switch, located above the EF bypass push button switch on the Control PC Board, will prevent these values from being changed. Once toggled, the output voltage adjustment push button and line drop compensation adjustment push button on the control panel will be disabled.

- (1) Open the front door of converter using an 8 mm Allen wrench.
- (2) Reach inside and toggle the keypad disable switch. The switch is located on the Control Panel PC Board above the EF bypass push button switches.
- (3) Toggle the switch back towards the Control PC Board to activate the switch and disable the output voltage adjustment and line drop compensation adjustment push buttons.
- (4) Close and latch the front door.

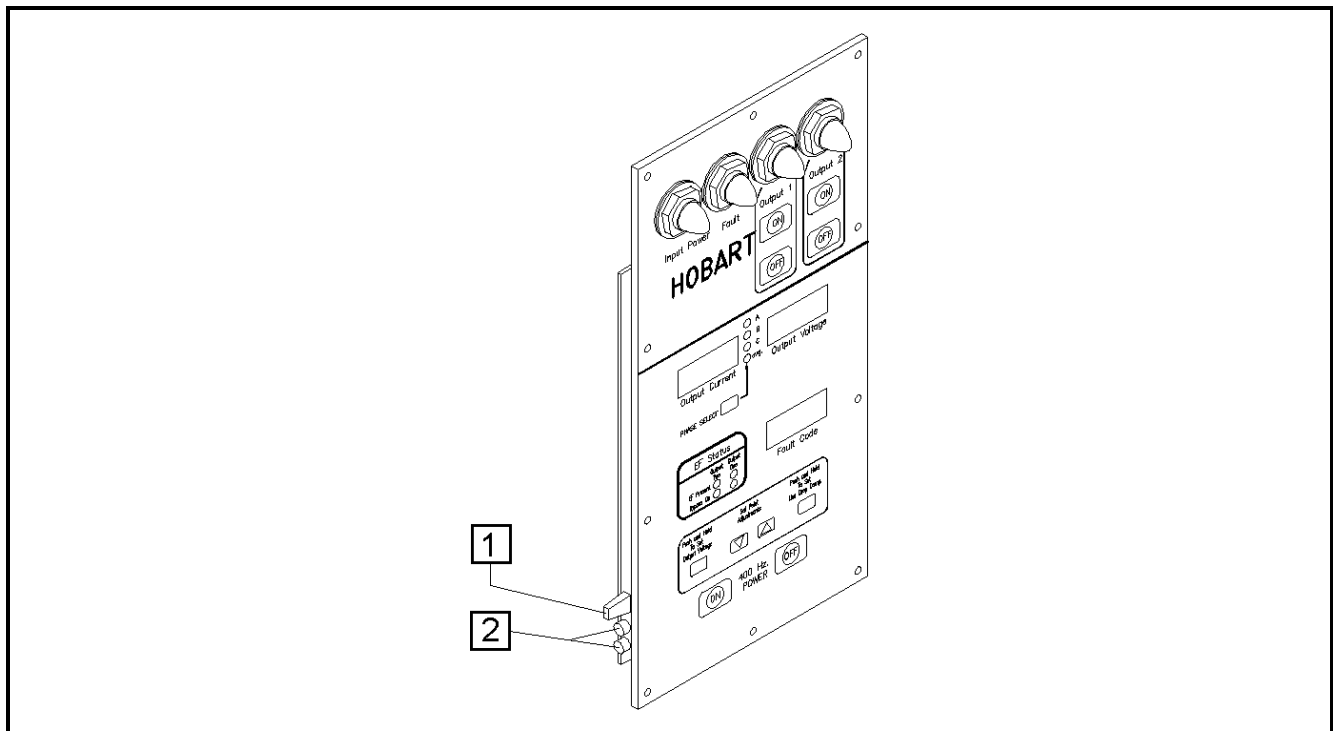

1. Key Pad Disable Switch

2. EF Bypass Push Buttons

Control Panel
Figure 2

j) EF Bypass switches

The EF Bypass output setting, which can only be changed while the converter is not running, permits a qualified technician to set the output mode either to "Normal" or to "EF Bypass"

The "Normal" setting is for delivery of power to an aircraft.

The "EF Bypass" setting bypasses the normal EF signal checking and permits the checking of various converter parameters, which would normally only be accessible while the signal is present. An output cannot be switched to EF bypass mode while an EF signal is present for that output. Additionally, if an EF signal is applied while the converter is in EF bypass mode, the converter will automatically switch back to the "Normal" mode.

Be aware that if EF bypass mode is selected, it is possible to deliver voltage to an output cable whether or not that cable is connected to an aircraft or load bank. Exercise extreme caution when selecting EF bypass mode.

WARNING

Output cables are "LIVE" when the EF Bypass mode is selected. Exercise extreme caution or FATAL SHOCK may result.

The EF Bypass push button switch is located on the bottom left of the control PC Board. There are two push buttons (output 1 and output 2, if applicable) which are used to toggle between normal and EF Bypass mode. The control panel will indicate the EF Bypass status.

The push button switch is spring assisted for momentary contact, meaning it does not lock in or out. Just press the push button in to change the setting and press again to go back.

- (1) Open the front door of converter using an 8 mm Allen wrench.
- (2) Reach inside and depress the EF bypass/normal push button switch to change the setting for that output.
- (3) Close and latch the front door.

Chapter 2 Servicing / Troubleshooting

Section 1 Troubleshooting

1) General

The troubleshooting information provided in this section is limited to procedures for determining the cause of faults and for restoring the converter to operation after faults develop which shut off the unit.

Calibration, service, and repair are to be done by Hobart Ground Power Service Department personnel, authorized distributors of Hobart Ground Power equipment, or trained qualified electronic technicians.

If you have any questions concerning your Hobart Ground Power equipment, contact our Service Department by mail, telephone, FAX or E-Mail.

Write: Hobart Ground Power
Service Department
1177 Trade Square East
Troy, Ohio 45373
U.S.A.

Call Inside U.S.A.: (800) 422-4166 (Parts)
(800) 422-4177 (Service)

Call From Foreign Countries: (937) 332-5050 (Parts)
(937) 332-5060 (Service)

FAX Inside U.S.A. (800) 367-4945

FAX From Foreign Countries: (937) 332-5121

E-Mail : service@hobartgroundpower.com

Web Page : www.hobartgroundpower.com

2) ADV Control Monitoring

The Hobart PoWerMaster ADV control system performs complete diagnostic testing upon each startup and continuous monitoring of all critical circuits and operating electrical parameters. If the control system senses a problem with one of the circuits, or if any of the electrical parameters exceeds its safe operating limit, the ADV control system will shut the converter down or may allow the converter to continue operation depending on the severity of the condition.

a) Warnings

Warnings are displayed when irregular conditions exist that are not necessarily a threat to the converter, aircraft, or personnel. The converter will continue to operate normally and will display the warning in the Fault Code Display.

When delivering AC power, an EF Bypass warning may occur when an output cable is removed from an aircraft before that output is turned off. EF Bypass warnings are stored in memory, as part of an event record, and can be used to indicate patterns of improper operation.

b) Faults

Faults result when any of the fault limits are exceeded, when an internal problem occurs, or under certain conditions that would cause injury to personnel, damage to an aircraft or the converter. The PoWerMaster ADV displays a fault code and the fault lamp will illuminate to alert the operator that something has gone wrong during operation. Faults are also stored in memory as event records. The fault limits and conditions are preset at the factory.

c) Fault Codes (See Figure 1)

The numbers that appear in the fault code display are used for troubleshooting problems with the PoWerMaster ADV. To read the four-digit fault code properly, it must be understood that the first two digits represent one half of the fault code and the last two digits represent the other half.

- The first two digits on the left side of the Fault Code represent the **Command**.
- The last two digits on the right side of the Fault Code represent the **Fault Condition**.

(1) Command

The ongoing operations conducted by the ADV are driven by the list of commands. The control PC board communicates these commands to all of the PC boards in the converter. The first half of the fault code identifies the command that was present when the fault occurred, as well as, the PC board where the commanded was sent.

(2) Fault Condition

The two numbers located on the right side of the four-digit fault code make up the ADV Fault. This half of the fault code identifies the detected fault, as well as, the PC board that detected it.

FAULT CODE QUICK REFERENCE CHART V2.03

----- COMMANDS -----	----- FAULTS -----
INVALID COMMAND	00 . 00 INVALID FAULT
ADV SELF TEST	01 . 07 IPC REAR DOOR SWITCH TRIP FAULT
CTL LAMP TEST	02 . 08 IPC FRONT DOOR SWITCH TRIP FAULT
IPC STATUS CHECK	04 . 09 IPC POS 5 VDC FAULT
SCB STATUS CHECK	05 . 10 IPC POS 12 VDC FAULT
MOD STATUS CHECK	06 . 11 IPC NEG 12 VDC FAULT
IOB STATUS CHECK	07 . 12 IPC SELF TEST FAULT
CTL STATUS CHECK	08 . 13 IPC DISCHARGE BOARD FAULT
TRB STATUS CHECK	09 . 14 IPC DISCHARGE FAULT
IPC INPUT VOLTAGE TEST	11 . 15 IPC 12 PULSE OVERHEAT FAULT
IPC SYSTEM POWER SUPPLY TEST	12 . 16 IPC SCR FAULT
IOB AUX POWER SUPPLY TEST	13 . 17 IPC BUS VOLTAGE LOW FAULT
TRB POWER SUPPLY TEST	14 . 18 IPC BUS VOLTAGE HIGH FAULT
CTL ID CHECK	15 . 19 IPC VOLTAGE TOO HIGH FAULT
IPC ID CHECK	16 . 20 IPC VOLTAGE TOO LOW FAULT
IOB CONTACTOR CHECK	17 . 21 IPC INPUT PHASE LOSS FAULT
CTL MEMBRANE CHECK	18 . 23 IPC COMM FAULT
TRB ID CHECK	19 . 27 SCB SELF TEST FAULT
TRB CONTACTOR TEST	20 . 28 SCB OUTPUT OVER FREQ FAULT
CTL REPORT CONFIG	22 . 29 SCB OUTPUT UNDER FREQ FAULT
CTL INOUT CONTACTOR TEST	23 . 30 SCB COMM FAULT
IOB PENDENT CHECK	26 . 34 MOD DRIVER BOARD 2 FAULT
IPC TEST DOOR SWITCHES	27 . 35 MOD SELF TEST FAULT
IPC 12 PULSE OVERHEAT TEST	28 . 36 MOD NBPT CURRENT TRIP FAULT
MOD OVERHEAT TEST	30 . 37 MOD VBUS OVER VOLTAGE FAULT
TRB OVERHEAT TEST	31 . 38 MOD DRIVER BOARD FAULT
IPC BUS DISCHARGE PCB TEST	32 . 39 MOD IGBT PAIR A FAULT
IPC DISCHARGE BUS	33 . 40 MOD IGBT PAIR A2 FAULT
IPC BUS VOLTAGE TEST	34 . 41 MOD IGBT PAIR B FAULT
MOD DRIVER TEST	41 . 42 MOD IGBT PAIR B2 FAULT
MOD IGBT A PAIR TEST	42 . 43 MOD IGBT PAIR C FAULT
MOD IGBT B PAIR TEST	43 . 44 MOD IGBT PAIR C2 FAULT
MOD IGBT C PAIR TEST	44 . 47 MOD HEATSINK OVERTEMP FAULT
ADV STANDBY	52 . 48 MOD TRANSFORMER OVERTEMP FAULT
ADV RAMP UP	54 . 49 MOD NBPT FAULT
IPC RAMP TO MINIMUM	59 . 50 MOD COMM FAULT
IPC RAMP TO 25 PERCENT	61 . 51 MOD VCESAT FAULT
IPC RAMP TO 50 PERCENT	63 . 52 TRB NEATSINK OVERTEMP FAULT
IPC RAMP TO FULL OUTPUT	67 . 53 TRB TRNASFORMER OVERTEMP FAULT
MOD RAMP TO FULL OUTPUT	79 . 54 TRB POS 5 VDC FAULT
SCB TEST OUTPUT FREQUENCY	82 . 55 TRB POS 12 VDC FAULT
TRB REGULATE DC	83 . 56 TRB NEG 12 VDC FAULT
CTL TEST OUTPUT	85 . 58 CTL TRANSFORMER ID FAULT
ADV 400 HZ ON	87 . 59 CTL INPUT CONTACTOR FAULT
ADV DC ON	88 . 60 CTL OUTPUT OVER VOLTAGE FAULT
ADV DC RAMP DOWN	89 . 61 CTL OUTPUT UNDER VOLTAGE FAULT
ADV RAMP DOWN	91 . 62 CTL OUTPUT 1 OVERLOAD FAULT
ADV SHUTDOWN	93 . 65 CTL OUTPUT 2 OVERLOAD FAULT
ADV FAULT SHUTDOWN	99 . 67 CTL SELF TEST FAULT
	. 68 CTL MACHINE OVERLOAD FAULT
	. 69 CTL DC OVER VOLTAGE FAULT
	. 70 CTL DC UNDER VOLTAGE FAULT
	. 72 CTL OUTPUT VOLTAGE IMBALANCE FAULT
	. 73 CTL MEMORY FAULT
	. 74 CTL UNBALANCED LOAD FAULT
	. 75 CTL MEMBRANE FAULT
	. 76 TRB SELF TEST FAULT
	. 77 TRB COMM FAULT
	. 78 TRB DC CONTACTOR FAULT
	. 80 IOB AUX24 FAULT
	. 81 IOB EF 1 VOLTAGE TOO HIGH FAULT
	. 82 IOB EF 1 VOLTAGE TOO LOW FAULT
	. 83 IOB EF 2 VOLTAGE TOO HIGH FAULT
	. 84 IOB EF 2 VOLTAGE TOO LOW FAULT
	. 85 IOB SELF TEST FAULT
	. 89 IOB REMOTE 1 FAULT
	. 90 IOB REMOTE 2 FAULT
	. 91 IOB CONTACTOR SENSE FAULT
	. 92 IOB COMM FAULT
	. 93 IOB CONTACTOR 1 CONTACTS STUCK FAULT
	. 94 IOB CONTACTOR 2 CONTACTS STUCK FAULT
	. 95 TRB ID FAULT
	. 96 TRB OUTPUT OVER VOLTAGE FAULT
	. 97 TRB OUTPUT UNDER VOLTAGE FAULT
	. 98 TRB OUTPUT OVERLOAD FAULT
	. 99 ADV COMM FAULT

COMMANDS
FAULTS

Fault Code

WARNINGS

EF 1	EF 1 NOT PRESENT WARNING
EF 2	EF 2 NOT PRESENT WARNING
Con1	CONTACTOR 1 NOT PRESENT WARNING
Con2	CONTACTOR 2 NOT PRESENT WARNING
door	DOOR OPEN WARNING
<small>front panel adjust</small>	FRONT PANEL ADJUST DISABLE WARNING

See Operation and Maintenance Manual
for detailed troubleshooting procedures

Commands and Faults
Figure 1

d) Self-Test

When input power is first applied, or after a fault has been reset, the converter performs a complete self diagnostic of its internal circuitry. The input power lamp will flash for several seconds indicating the self test is in process.

During a self test, the converter will perform ADV Commands "01" through "52.". The converter performs each test one at a time and in the order listed. When a fault is detected during self test, the current **Command** and detected **Fault** are indicated in the fault code display.

By referencing the fault code chart, the converter state and exact nature of the fault can be determined. Not only is the failed test identified, but the tests that passed are also known. The self test checking order is such that failures which can cause misleading symptoms (ex. bad power supply) are checked first. This method yields a high degree of troubleshooting accuracy.

e) Ramp Up

When an operator presses the ON button to apply power to an aircraft, the converter performs a number of commands for an orderly ramp up. During ramp up, the converter also performs self diagnostics. The output contactor will only close when the output power is within specifications.

During ramp up, the converter will perform ADV Commands "54." through "87." The converter performs each command one at a time and in the order listed. When a fault is detected during ramp up, the current **Command** and detected **Fault** are indicated in the fault code display.

By referencing the fault code chart, the converter state and exact nature of the fault can be determined. During ramp up, not only is the failed command identified, but the commands that passed are also known. The commands are in an order such that failures which can cause misleading symptoms are checked first. When a fault is reset, the converter will perform a self-test and will often detect the fault again revealing additional information. This method yields a high degree of troubleshooting accuracy.

f) Operation Monitoring

While applying power to an aircraft, the converter continually monitors all critical circuits and operating electrical parameters.

During 400 Hz AC operation, the converter continually performs ADV Command "87" (ADV 400Hz ON). When a fault is detected during the 400Hz operation, the **Command** and the detected **Fault** are indicated in the fault code display.

By referencing the fault code chart, the converter state and exact fault can be determined. When a fault is reset, the converter will perform a self test and will often detect the fault again revealing additional information. This method yields a high degree of troubleshooting accuracy.

g) Fault Code Chart and Table

Figure 1 contains a quick reference chart. This chart is also located inside the front door of the converter. A complete troubleshooting chart can be found on the following pages of this section.

h) Troubleshooting examples

(1) Example 1

The converter is operating and delivering 400 Hz power to an aircraft when the front door of the converter is opened. The unit shuts down and the red fault lamp on the control panel illuminates. The fault code display indicates an "87.08".

The numerals "87" on the left of the fault code display indicate that the machine was operating and delivering 400Hz power when the fault occurred.

The numerals "08" on the right of the fault code display indicate that the IPC PC board detected a front door switch trip during operation.

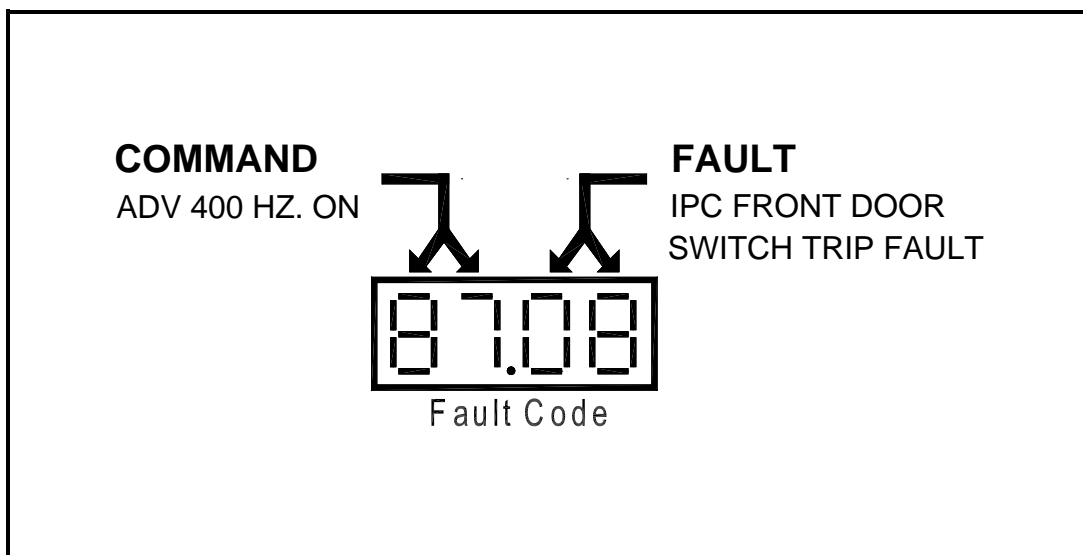

Fault Code Example 1
Figure 2

(2) Example 2

Now with the door still open, the fault is reset by pressing the OFF/RESET push button on the control panel. The Input power lamp begins to flash to indicate self test in process. After a couple of seconds, another fault occurs and the fault code display now indicates a "27.08".

The numerals "27" on the left of the fault code display indicate that the converter was executing a self test and that the IPC PC board was testing the door switches.

The "27." also indicates that that commands "01" through "26" passed and that therefore areas like the power supplies, contactors, and remote pendants are functioning properly.

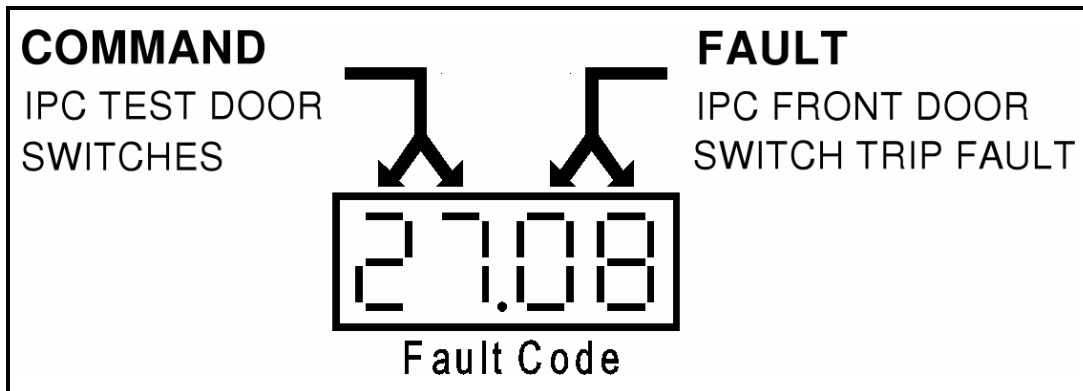

Fault Code Example 2
Figure 3

The numeral “08” on the right of the fault code display indicates that the IPC PC board detected a front door switch trip during self test.

Latch the door properly and press the OFF/RESET push button. The input power lamp flashes for several seconds to indicate self test. The input power lamp then illuminates continuously to indicate the converter is now ready for use.

COMMANDS	
INVALID COMMAND	00 - PASSED
ADV SELF TEST	01 - PASSED
CTL LAMP TEST	02 - PASSED
IPC STATUS CHECK	04 - PASSED
SCB STATUS CHECK	05 - PASSED
MOD STATUS CHECK	06 - PASSED
IOB STATUS CHECK	07 - PASSED
CTL STATUS CHECK	08 - PASSED
TRB STATUS CHECK	09 - PASSED
IPC INPUT VOLTAGE TEST	11 - PASSED
IPC SYSTEM POWER SUPPLY TEST	12 - PASSED
IOB AUX. POWER SUPPLY TEST	13 - PASSED
TRB POWER SUPPLY TEST	14 - PASSED
CTL ID CHECK	15 - PASSED
IPC ID CHECK	16 - PASSED
IOB CONTACTOR CHECK	17 - PASSED
CTL MEMBRANE CHECK	18 - PASSED
TRB ID CHECK	19 - PASSED
TRB CONTACTOR CHECK	20 - PASSED
CTL REPORT CONFIG.	22 - PASSED
CTL INPUT CONTACTOR TEST	23 - PASSED
IOB PENDENT CHECK	26 - PASSED
IPC TEST DOOR SWITCHES	27 - FAILED
IPC 12 PULSE OVERHEAT TEST	28
MOD OVERHEAT TEST	30
TRB OVERHEAT TEST	31
IPC BUS DISCHARGE PCB TEST	32
IPC DISCHARGE BUS	33
IPC BUS VOLTAGE TEST	34
MOD DRIVER TEST	41
MOD IGBT "A" PAIR TEST	42
MOD IGBT "B" PAIR TEST	43
MOD IGBT "C" PAIR TEST	44
ADV STANDBY	52

SELF TEST	
INVALID COMMAND	00 - PASSED
ADV SELF TEST	01 - PASSED
CTL LAMP TEST	02 - PASSED
IPC STATUS CHECK	04 - PASSED
SCB STATUS CHECK	05 - PASSED
MOD STATUS CHECK	06 - PASSED
IOB STATUS CHECK	07 - PASSED
CTL STATUS CHECK	08 - PASSED
TRB STATUS CHECK	09 - PASSED
IPC INPUT VOLTAGE TEST	11 - PASSED
IPC SYSTEM POWER SUPPLY TEST	12 - PASSED
IOB AUX. POWER SUPPLY TEST	13 - PASSED
TRB POWER SUPPLY TEST	14 - PASSED
CTL ID CHECK	15 - PASSED
IPC ID CHECK	16 - PASSED
IOB CONTACTOR CHECK	17 - PASSED
CTL MEMBRANE CHECK	18 - PASSED
TRB ID CHECK	19 - PASSED
TRB CONTACTOR CHECK	20 - PASSED
CTL REPORT CONFIG.	22 - PASSED
CTL INPUT CONTACTOR TEST	23 - PASSED
IOB PENDENT CHECK	26 - PASSED
IPC TEST DOOR SWITCHES	27 - FAILED
IPC 12 PULSE OVERHEAT TEST	28
MOD OVERHEAT TEST	30
TRB OVERHEAT TEST	31
IPC BUS DISCHARGE PCB TEST	32
IPC DISCHARGE BUS	33
IPC BUS VOLTAGE TEST	34
MOD DRIVER TEST	41
MOD IGBT "A" PAIR TEST	42
MOD IGBT "B" PAIR TEST	43
MOD IGBT "C" PAIR TEST	44
ADV STANDBY	52

Figure 4

Troubleshooting Table		
ADV Commands		
Fault code	Name	Description
00. __	Invalid Command	
01. __	ADV SELF TEST	All boards go to self test mode
02. __	CTL LAMP TEST	CTL turn on all front panel lights
03. __		
04. __	IPC STATUS CHECK	IPC check PC board status
05. __	SCB STATUS CHECK	SCB check PC board status
06. __	MOD STATUS CHECK	MOD check PC board status
07. __	IOB STATUS CHECK	IOB check PC board status
08. __	CTL STATUS CHECK	CTL Check PC board status
09. __	TRB STATUS CHECK	TRB check PC board status
10. __		
11. __	IPC INPUT VOLTAGE TEST	IPC test input voltage within limits
12. __	IPC SYSTEM POWER SUPPLY TEST	IPC test system power supplies within limits
13. __	IOB AUX. POWER SUPPLY TEST	IOB test auxiliary power supply within limits
14. __	TRB POWER SUPPLY TEST	TRB test PC board power supply within limits
15. __	CTL ID CHECK	CTL detect main transformer rating
16. __	IPC ID CHECK	IPC detect 12-pulse transformer rating
17. __	IOB CONTACTOR CHECK	IOB detect contactors
18. __	CTL MEMBRANE CHECK	CTL check front switch panel for shorts
19. __	TRB ID CHECK	TRB detect DC option presence
20. __	TRB CONTACTOR CHECK	TRB check for contactor open
21. __		
22. __	CTL REPORT CONFIG.	CTL display kVA rating and number of contactors
23. __	CTL INPUT CONTACTOR TEST	CTL check for DC option input contactor open
24. __		
25. __		
26. __	IOB PENDENT CHECK	IOB check for stuck pendent button
27. __	IPC TEST DOOR SWITCHES	IPC test door switches for closed position
28. __	IPC 12 PULSE OVERHEAT TEST	IPC test 12-pulse transformer for overheat
29. __		
30. __	MOD OVERHEAT TEST	MOD test heat sink and main transformer for overheat

Troubleshooting Table		
ADV Commands		
Fault code	Name	Description
31. __	TRB OVERHEAT TEST	TRB test T/R heat sink and transformer for overheat
32. __	IPC BUS DISCHARGE PCB TEST	IPC test bus discharge board
33. __	IPC DISCHARGE BUS	IPC command bus discharge PC board to discharge
34. __	IPC BUS VOLTAGE TEST	IPC test bus voltage
35. __		
36. __		
37. __		
38. __		
39. __		
40. __		
41. __	MOD DRIVER TEST	MOD test driver PC board
42. __	MOD IGBT "A" PAIR TEST	MOD test IGBT pair "A" for shorts
43. __	MOD IGBT "B" PAIR TEST	MOD test IGBT pair "B" for shorts
44. __	MOD IGBT "C" PAIR TEST	MOD test IGBT pair "C" for shorts
45. __		
46. __		
47. __		
48. __		
49. __		
50. __		
51. __		
52. __	ADV STANDBY	All boards go to stand-by mode
53. __		
54. __	ADV RAMP UP	All boards go to ramp up mode
55. __		
56. __		
57. __		
58. __		
59. __	IPC RAMP TO MINIMUM	IPC ramp SCR duty cycle to minimum bus voltage
60. __		
61. __	IPC RAMP TO 25%	IPC ramp SCR duty cycle to 25% duty cycle

Troubleshooting Table		
ADV Commands		
Fault code	Name	Description
62. __		
63. __	IPC RAMP TO 50%	IPC ramp SCR duty cycle to 50% duty cycle
64. __		
65. __		
66. __		
67. __	IPC RAMP TO FULL OUTPUT	IPC ramp SCR duty cycle to full output duty cycle
68. __		
69. __		
70. __		
71. __		
72. __		
73. __		
74. __		
75. __		
76. __		
77. __		
78. __		
79. __	MOD RAMP TO FULL OUTPUT	MOD ramp 400 Hz. voltage to full
80. __		
81. __		
82. __	SCB TEST OUTPUT FREQUENCY	SCB test 400 Hz. frequency within limits
83. __	TRB REGULATE DC	TRB regulate DC, if DC option activated
84. __		
85. __	CTL TEST OUTPUT	CTL test 400 Hz. voltage within limits
86. __		
87. __	ADV 400 HZ. ON	All boards go to 400 Hz. on mode
88. __	ADV DC ON	All boards go to DC ON mode, if DC activated
89. __	ADV DC RAMP DOWN	All boards ramp down from DC operation
90. __		
91. __	ADV RAMP DOWN	All boards ramp down from AC operation
92. __		

Troubleshooting Table		
ADV Commands		
Fault code	Name	Description
93. __	ADV SHUTDOWN	All boards shutdown (normal shutdown)
94. __		
95. __		
96. __		
97. __		
98. __		
99. __	ADV FAULT SHUTDOWN	All boards shutdown (abnormal shutdown)

Troubleshooting Table			
Faults			
Fault code	Name	Possible Cause(s)	Corrective Action
___.00	Invalid Fault		
___.01			
___.02			
___.03			
___.04			
___.05			
___.06			
___.07	IPC REAR DOOR SWITCH TRIP FAULT	Rear door is open Interlock switch is defective	Close and latch rear door. Replace interlock switch S2
___.08	IPC FRONT DOOR SWITCH TRIP FAULT	Front door is open Interlock switch is defective	Close and latch front door. Replace interlock switch S7
___.09	IPC POS 5 VDC FAULT	Power supply PS2 is defective	Replace PS2
___.10	IPC POS 12 VDC FAULT	Power supply PS1 is defective	Replace PS1
___.11	IPC NEG 12 VDC FAULT	Power supply PS2 is defective	Replace PS2
___.12	IPC SELF TEST FAULT	IPC board failed self-test	Replace IPC board
___.13	IPC DISCHARGE BOARD FAULT	Discharge board is defective Discharge resistor is open	Replace discharge board A7 Replace discharge resistor R3
___.14	IPC DISCHARGE FAULT	Discharge board is defective. Discharge resistor is open	Replace discharge board A7 Replace discharge resistor R3
___.15	IPC 12 PULSE OVERHEAT FAULT	Filter Clogged Fan is inoperative Defective thermal switch in 12 pulse transformer	Clean or replace filter Check fan Replace thermal switch
___.16	IPC SCR FAULT	SCR shorted or open	Replace SCR
___.17	IPC BUS VOLTAGE LOW FAULT	SCR open Input power control board defective	Replace SCR Replace IPC board A4
___.18	IPC BUS VOLTAGE HIGH FAULT	Improper no break power transfers (NBPT)	Check output cable and load
___.19	IPC INPUT VOLTAGE TOO HIGH FAULT	Input voltage too high Input power control board defective	Check input source, correct as necessary Replace input power control board A4

Troubleshooting Table			
Faults			
Fault code	Name	Possible Cause(s)	Corrective Action
___.20	IPC INPUT VOLTAGE TOO LOW FAULT	Input voltage too low Input power control board defective	Check input source, correct as necessary Replace input power control board A4
___.21	IPC INPUT PHASE LOSS FAULT	Loss of input phase was detect Input power control board defective	Check input source, correct as necessary Replace input power control board A4
___.22			
___.23	IPC COMM FAULT	Communications fault on input control board	Replace input power control board A4
___.24			
___.25			
___.26			
___.27	SCB SELF TEST FAULT	Signal conditioning board failed self test	Replace signal conditioning board A6
___.28	SCB OUTPUT OVER FREQ FAULT	Modulator board defective	Replace modulator board A3
___.29	SCB OUTPUT UNDER FREQ FAULT	Modulator board defective	Replace modulator board A3
___.30	SCB COMM FAULT	Communications fault on signal conditioning board	Replace signal conditioning board A6
___.31			
___.32			
___.33			
___.34	MOD DRIVER BOARD 2 FAULT	Defective driver board	Replace driver board A10
___.35	MOD SELF TEST FAULT	Modulator board failed self test	Replace modulator board A3
___.36	MOD NBPT CURRENT TRIP FAULT	High current no break power transfer	Check output cable and load. Reset and restart converter
___.37	MOD VBUS VOLTAGE FAULT	Faulty no break power transfer	Reset and restart converter
___.38	MOD DRIVER BOARD FAULT	Defective driver board	Replace drive board A5
___.39	MOD IGBT A FAULT	Phase A IGBT defective	Replace PM1 & PM2
___.40	MOD IGBT A2 FAULT	Phase A2 IGBT defective	Replace PM7 & PM8
___.41	MOD IGBT B FAULT	Phase B IGBT defective	Replace PM3 & PM4
___.42	MOD IGBT B2 FAULT	Phase B2 IGBT defective	Replace PM9 & PM10
___.43	MOD IGBT C FAULT	Phase C IGBT defective	Replace PM5 & PM6
___.44	MOD IGBT C2 FAULT	Phase C2 IGBT defective	Replace PM11 & PM12
___.45			

Troubleshooting Table			
Faults			
Fault code	Name	Possible Cause(s)	Corrective Action
___.46			
___.47	MOD HEATSINK OVETEMP FAULT	Filter clogged Fan inoperable Defective thermal switch	Clean or replace filter Check fan Replace switch S4
___.48	MOD TRANSFORMER OVERTEMP FAULT	Filter clogged Fan inoperable Defective thermal switch	Clean or replace filter Check fan Replace switch S5
___.49	MOD NBPT FAULT	Improper no break power transfer	Reset and restart converter
___.50	MOD COMM FAULT	Communications fault on modulator board	Replace modulator board A3
___.51	MOD VCESAT FAULT	High current no break power transfer Shorted output Defective IGBT Defective driver board	Reset and restart converter Check output cable and load Reset and restart converter Replace IGBT pair Replace driver board
___.52	TRB HEAT SINK OVERTEMP FAULT	Filter clogged Fan inoperable Defective thermal switch	Clean or replace filter Check fan Replace switch S10
___.53	TRB TRANSFORMER OVERTEMP FAULT	Filter clogged Fan inoperable Defective thermal switch	Clean or replace filter Check fan Replace switch S11
___.54	TRB POS 5 VDC FAULT	T/R PCB is defective	Replace T/R PC board A8
___.55	TRB POS 12 VDC FAULT	T/R PCB is defective	Replace T/R PC board A8
___.56	TRB NEG 12 VDC FAULT	T/R PCB is defective	Replace T/R PC board A8
___.57			
___.58	CTL TRANSFORMER ID FAULT	Transformer ID resistor is missing, open, or incorrect value	Replace resistor R4
___.59	CTL RS232 FAULT	RS232 Communications Fault	Replace control board A2.

Troubleshooting Table			
Faults			
Fault code	Name	Possible Cause(s)	Corrective Action
--.60	CTL OUTPUT OVER VOLTAGE FAULT	Voltage set too high Line drop compensation set too high Signal conditioning board defective Modulator board defective	Reset and restart converter Reset and restart converter Replace signal conditioning board A6 Replace modulator board A3
--.61	CTL OUTPUT UNDER VOLTAGE FAULT	Voltage set too low Signal conditioning board defective Modulator board defective	Reset and restart converter Replace signal conditioning board A6 Replace modulator board A3
--.62	CTL OUTPUT 1 OVERLOAD FAULT	Overload on Output 1	Reset and restart converter
--.63			
--.64			
--.65	CTL OUTPUT 2 OVERLOAD FAULT	Overload on Output 2	Reset and restart converter
--.66			
--.67	CTL SELF TEST FAULT	Control board defective	Replace control board A2
--.68	CTL MACHINE OVERLOAD FAULT	Load over rating of converter	Reset and restart converter
--.69	CTL DC OVERVOLTAGE FAULT	Voltage set too high Control board defective	Reset and restart converter Replace control board A2
--.70	CTL DC UNDERVOLTAGE FAULT	Voltage set too low Control board defective	Reset and restart converter Replace control board A2
--.71			
--.72	CTL OUTPUT VOLTAGE IMBALANCE FAULT	Load is unbalanced Modulator board is defective Signal conditioning board is defective	Reset and restart converter Replace modulator board A3 Replace signal conditioning board A6
--.73	CTL MEMORY FAULT	Control board is defective	Replace control board A2
--.74	CTL UNBALANCED LOAD FAULT	Load is unbalanced Output cable is defective	Reset and restart converter Check output cable

Troubleshooting Table			
Faults			
Fault code	Name	Possible Cause(s)	Corrective Action
___.75	CTL MEMBRANE FAULT	Button held on during self test Button stuck on control membrane	Reset and restart converter. Replace membrane switch panel S1
___.76	TRB SELF TEST FAULT	T/R board defective	Replace T/R board A8
___.77	TRB COMM FAULT	Communications fault on T/R board	Replace T/R board A8
___.78	TRB DC CONTACTOR FAULT	DC contactor stuck	Replace DC contactor
___.79	IOB SELF TEST FAULT	I/O board failed self test	Replace I/O board A1
___.80	IOB AUX24 FAULT	I/O board fuse blown	Replace I/O board fuse
___.81	IOB EF 1 VOLTAGE TOO HIGH FAULT	EF voltage being sent from aircraft on output 1 to the converter on TB1-6 is too high Output cable is defective	Reset and restart converter Check output cable
___.82	IOB EF 1 VOLTAGE TOO LOW FAULT	EF voltage being sent from aircraft on output 1 to the converter on TB1-6 is too low Output cable is defective	Reset and restart converter Check output cable
___.83	IOB EF 2 VOLTAGE TOO HIGH FAULT	EF voltage being sent from aircraft on output 2 to the converter on TB1-6 is too high Output cable is defective.	Reset and restart converter Check output cable
___.84	IOB EF 2 VOLTAGE TOO LOW FAULT	EF voltage being sent from aircraft on output 2 to the converter on TB1-6 is too low Output cable is defective.	Reset and restart converter Check output cable
___.85	IOB SELF TEST FAULT	I/O board defective	Replace I/O board A1
___.86			
___.87			
___.88			
___.89	IOB REMOTE 1 FAULT	Button held down during self test Stuck button or open wire on remote for output 1	Reset and restart converter Repair and replace remote pushbuttons

Troubleshooting Table			
Faults			
Fault code	Name	Possible Cause(s)	Corrective Action
___.90	IOB REMOTE 2 FAULT	Button held down during self test Stuck button or open wire on remote for output 2	Reset and restart converter Repair and replace remote pushbuttons
___.91	IOB CONTACTOR SENSE FAULT	Contactor coil open	Replace contactor
___.92	IOB COMM FAULT	Communications fault on I/O board	Replace I/O board A1
___.93	IOB CONTACTOR 1 CONTACTS STUCK FAULT	Contactor on output 1 stuck closed	Replace output contactor K1
___.94	IOB CONTACTOR 2 CONTACTS STUCK FAULT	Contactor on output 2 stuck closed	Replace output contactor K2
___.95	TRB ID FAULT	Transformer ID resistor is missing, open, or incorrect value	Replace resistor R56
___.96	TRB OUTPUT OVERVOLTAGE FAULT	Voltage set too high T/R board defective	Reset and restart converter Replace T/R board A8
___.97	TRB OUTPUT UNDERVOLTAGE FAULT	Voltage set too low T/R board defective	Reset and restart converter Replace T/R board A8
___.98	TRB OUTPUT OVERLOAD FAULT	DC load over rating of converter	Reset and restart converter
___.99	ADV COMM FAULT	Converter communications fault	Replace control board A2

AC 400 Hz Converter Protective Output Faults	
AC Over Voltage	Over Voltage Trips at 124 to 125 volts after a 1-second time delay Trips at 140 volts in 160 milliseconds Trips at 180 volts in 50 milliseconds
AC Under Voltage	Trips at any value between 60 volts and 104 volts after a 8-second time delay. Trips immediately at any voltage below 60 volts.
AC Over Frequency	Trips at any value between 430-Hz and 440-Hz after a 14-second time delay. Trips immediately at any frequency above 440-Hz.
AC Under Frequency	Trips at any value between 350-Hz and 365-Hz after a 14-second time delay. Trips immediately at any frequency below 350-Hz.
AC Overloads	Trips in approximately 10 minutes at 125% load of converter rating. Trips in approximately 30 seconds at 150% load of converter rating. Trips in approximately 10 seconds at 200% load of converter rating.

Fault Limits
Figure 5

Fault Limits are described above and are detailed in the Fault Code Chart earlier in the chapter.

3) Troubleshooting Procedures

The remainder of this section provides further explanation of the troubleshooting information given in the preceding tables. When necessary, the following detailed testing procedures are given, as an example, to help determine what components may be in need of repair or replacement. Actual removal and replacement instructions are given in Chapter 3. Contact Hobart Ground Power service department for additional testing procedures as necessary.

NOTE: There are no procedures listed for testing or replacing individual components on any PC board. Inoperative PC boards can not be repaired in the field, but must be replaced as a complete unit. PC boards may be returned to the factory for replacement. Contact Hobart Ground Power service department for parts and replacement instructions.

WARNING

High voltages may be present inside the converter cabinet, even when the unit is off. Exercise extreme caution when testing and replacing components or FATAL SHOCK may result.

WARNING

Before testing any components inside the converter, always make certain that the DC bus is fully discharged. In certain circumstances, such as a failure of the DC bus discharge PC board, the DC bus may not be discharged when the converter shuts down. Several hundred volts may still be present at the bus.

a) Door Switch Fault

The converter is equipped with two door interlock switches. Opening either door will disable the unit. Therefore both doors must be closed to operate the unit. If a door interlock fault occurs, follow the procedure below to determine the cause and restore the converter to normal operation.

- (1) Make sure both the front and back converter doors are tightly closed and all six latches are fastened. To fasten the latches, turn each one clockwise with an 8 mm (5/16 inch) Allen wrench until it stops.
- (2) Press the control panel 400 Hz OFF/RESET push button to reset the converter.
- (3) Restart the converter normally and attempt to deliver output power to a load bank.
- (4) If this fault reoccurs, one or both of the door interlock switches may be faulty. To test the switches, follow these steps:
 - a Disconnect input power from the converter.
 - b Open the front and back doors by turning all three latches counterclockwise with an 8 mm Allen wrench. Exercise extreme caution while the doors are open, as high voltages may be present, even when the unit is off.
 - c Test the DC bus with a voltmeter to be sure that it is fully discharged. The bus can be tested using test jacks TP1 and TP2 on the Signal Conditioning PC board. If the bus is not discharged, close the converter door, wait at least 15 minutes, and test it again. Do not perform any work inside the converter while the DC bus remains charged.

- d Check the continuity of each door interlock switch with an ohmmeter. When the doors are open, the switch contacts will also be open, and there should be approximately 100 ohms or more across the terminals.
- e Press and hold the white post in front of each switch and measure the continuity. The switch contacts will be closed, and there should be no resistance across the terminals.
- f If a switch is faulty, it must be replaced.

b) Output Current Overload Fault

If an output overload current fault occurs, follow the test procedure below to determine the cause and restore the converter to normal operation.

- (1) Make sure the aircraft is not placing a load on the converter greater than the unit power rating. Turn off unnecessary accessories on the aircraft. Check for a shorted output or output cable.
- (2) Press the control panel 400 Hz OFF/RESET button to reset the converter.
- (3) Restart the converter normally and attempt to deliver output power.

c) Neutral Line Current Fault

Unequal loading of the output phases by the aircraft or there maybe one or two opened or shorted phases in the output cable or at the aircraft, which may cause a neutral line current fault. If a neutral line current fault occurs, follow the procedure below to determine the cause and restore the converter to normal operation.

- (1) Make sure the aircraft is not placing an excessive load on one output phase. The loads placed on each phase should be nearly equal. Check the output cable, aircraft plug, and contactor connections, and repair as necessary.
- (2) Press the control panel 400 Hz OFF/RESET button to reset the converter.
- (3) Restart the converter normally and attempt to deliver output power.

Section 2 Calibration

IMPORTANT

Before attempting to make tests and adjustments on the converter, READ THIS ENTIRE SECTION to become familiar with the proper procedures.

As explained previous in this manual, the ADV control system performs monitoring and testing of critical circuits prior to and during operation. After making any major repair, replacing major parts, or overhaul, adjustments may be required. Adjustments or calibration may need to be made from inside the converter using the Signal Conditioning PC board or from the ADV service tool software from a remote PC. If the ADV service tool software is unavailable, contact the Hobart Ground Power service department for details on how to obtain the software.

1) Test Preparation

- a) Calibration adjustments must be made while the front door is open and the converter is sending output power. All test measurements can be taken behind the front door of the converter or at the ends of the output cables. It is not necessary to have access to the rear door for calibration purposes. Make sure the rear door is tightly closed because the converter is equipped with two door interlock switches. Opening either door will prevent the converter from operating unless the door switches are placed in bypass as shown in Figure 2.
- b) Disconnect input power from the converter.

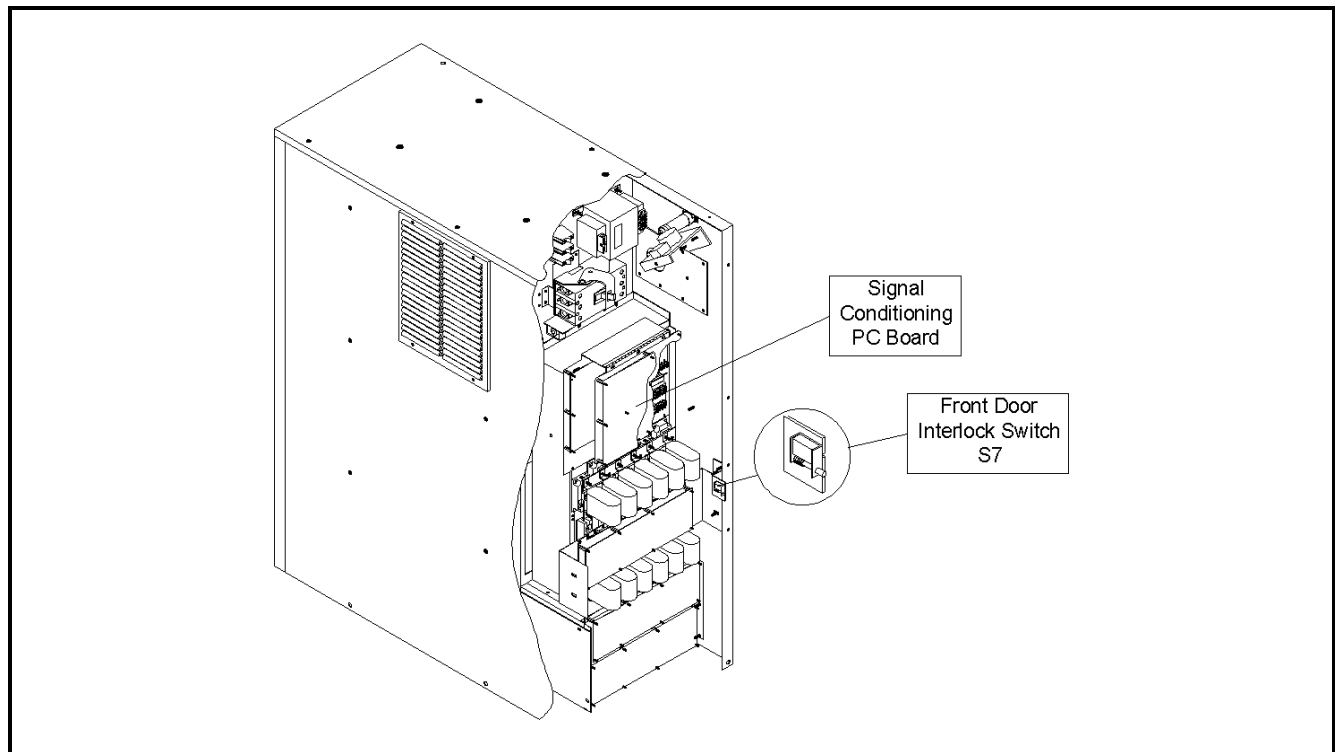

Signal Conditioning Board and Door Interlock Switch Location
Figure 1

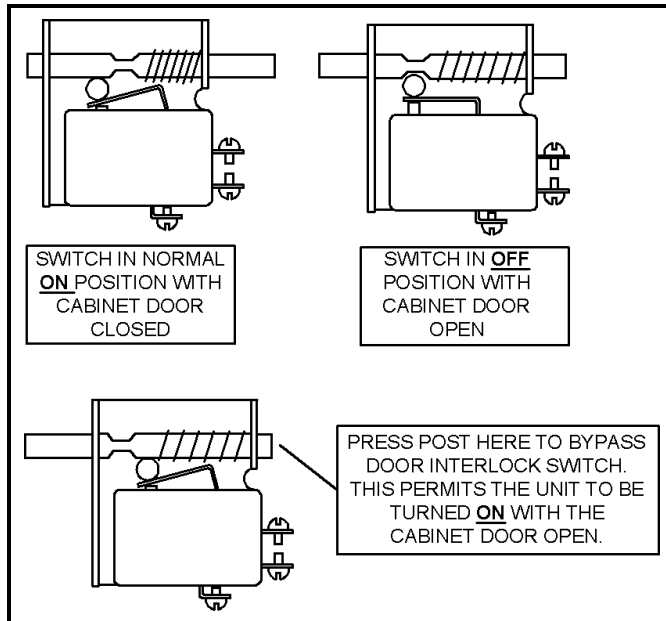
**Door Interlock Switches (S2 & S7)**
Figure 2**WARNING**

High voltages may be present inside the converter cabinet, even when the unit is off. Exercise extreme caution when testing and replacing components or FATAL SHOCK may result.

WARNING

Before testing any components inside the converter, always make certain that the DC bus is fully discharged. In certain circumstances, such as a failure of the DC bus discharge PC board, the DC bus may not be discharged when the converter shuts down. Several hundred volts may still be present at the bus.

- c) To bypass S7, open front door by turning all three latches counterclockwise with an 8 mm Allen wrench.
- d) Pull the end of the white post next to the switch until it locks into place. S7 is now bypassed and will allow the converter to operate while the front door is open.
- e) Apply rated input power. The green INPUT POWER lamp will flash, indicating the self-test mode and then stay illuminated if no faults are detected.

WARNING

Do not perform any work inside the converter when input power is applied.

- f) Use output cable of proper size and length for the converter's power output rating. Connect output cable plug connector to aircraft receptacle or load bank. Be sure connectors are mated fully and securely. Make a general inspection of all wiring and terminals.

WARNING

Never disconnect an output cable while output power is on.

2) Calibration

The ADV Control provides automatic and continuous monitoring of numerous critical electrical operating parameters.

WARNING

Exercise extreme caution while performing calibrations. FATAL SHOCK OR PERMANENT DAMAGE TO EQUIPMENT may result if proper procedures and precautions are not taken.

If a qualified technician, after measuring various voltage or current values with their own testing equipment, discovers that the readings obtained do not match the values displayed by the ADV control panel, it is possible to change the calibration of the unit to bring the displayed values into agreement with the measured values. This calibration procedure should be performed especially after making major repair, replacing major parts, or performing an overhaul.

CAUTION

Only qualified personnel using accurate test equipment should perform calibrations. Otherwise FATAL SHOCK OR PERMANENT DAMAGE to the converter could result.

a) Output Voltage Calibration Procedure

The voltage settings on this converter are calibrated at the factory. However, on-site adjustments may be made using the following procedure.

To begin the calibration procedure, the converter must be ON and a load must be present. The following calibrations are to be performed on the Signal Conditioning PC board, which is located inside the front door. The SCB has a series of LEDs that indicate which signal is being calibrated. The LED's VA, VB, and VC are used to indicate that the output phase voltages of A, B, and C being adjusted.

WARNING

A reliable and accurate voltmeter is needed to complete this calibration.

WARNING

High voltages will be present inside the converter cabinet when the unit is on. Exercise extreme caution when taking measurements or FATAL SHOCK may result.

- (1) Turn the converter on, and place a load on converter output.
- (2) Press and hold the POT SELECT push button for 3 seconds until the IA1 LED illuminates.
- (3) Press and release the POT SELECT button repeatedly until the VA LED illuminates.

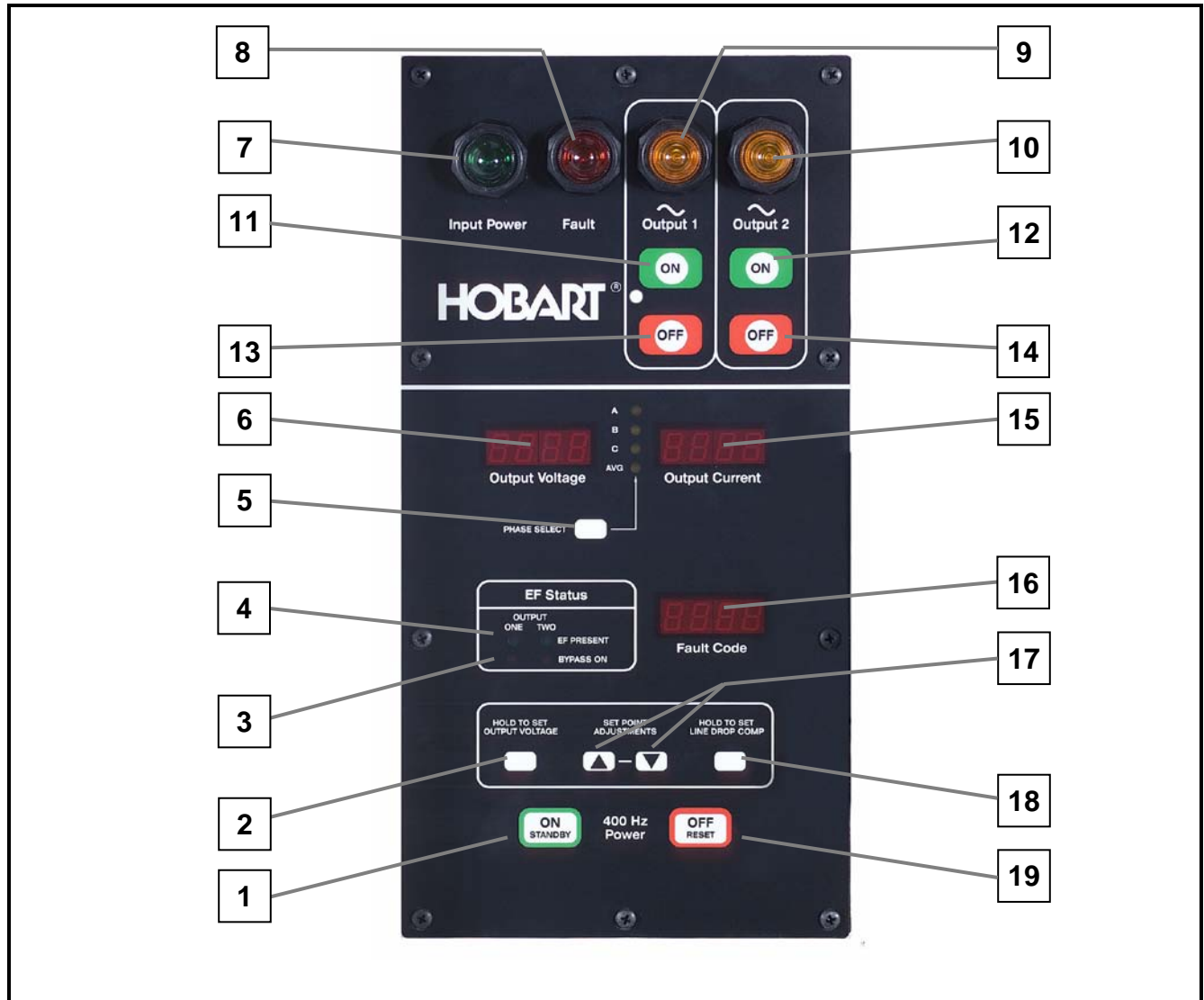

- | | |
|--|---|
| 1. 400 Hz Power On Push Button | 11. Output 1 On Push Button |
| 2. Output Voltage Adjustment Push Button | 12. Output 2 On Push Button (if applicable) |
| 3. Bypass On Lamp | 13. Output 1 Off Push Button |
| 4. EF Present Lamp | 14. Output 2 Off Push Button (if applicable) |
| 5. Phase Select Push Button | 15. Output Current Display |
| 6. Output Voltage Display | 16. Fault Code Display |
| 7. Input Power Lamp | 17. Set Point Up And Down Adjustment Push Buttons |
| 8. Fault Lamp | 18. Line Drop Compensation Adjustment Push Button |
| 9. Output 1 Lamp | 19. 400 Hz Power Off Push Button |
| 10. Output 2 Lamp (if applicable) | |

Control Panel
Figure 3

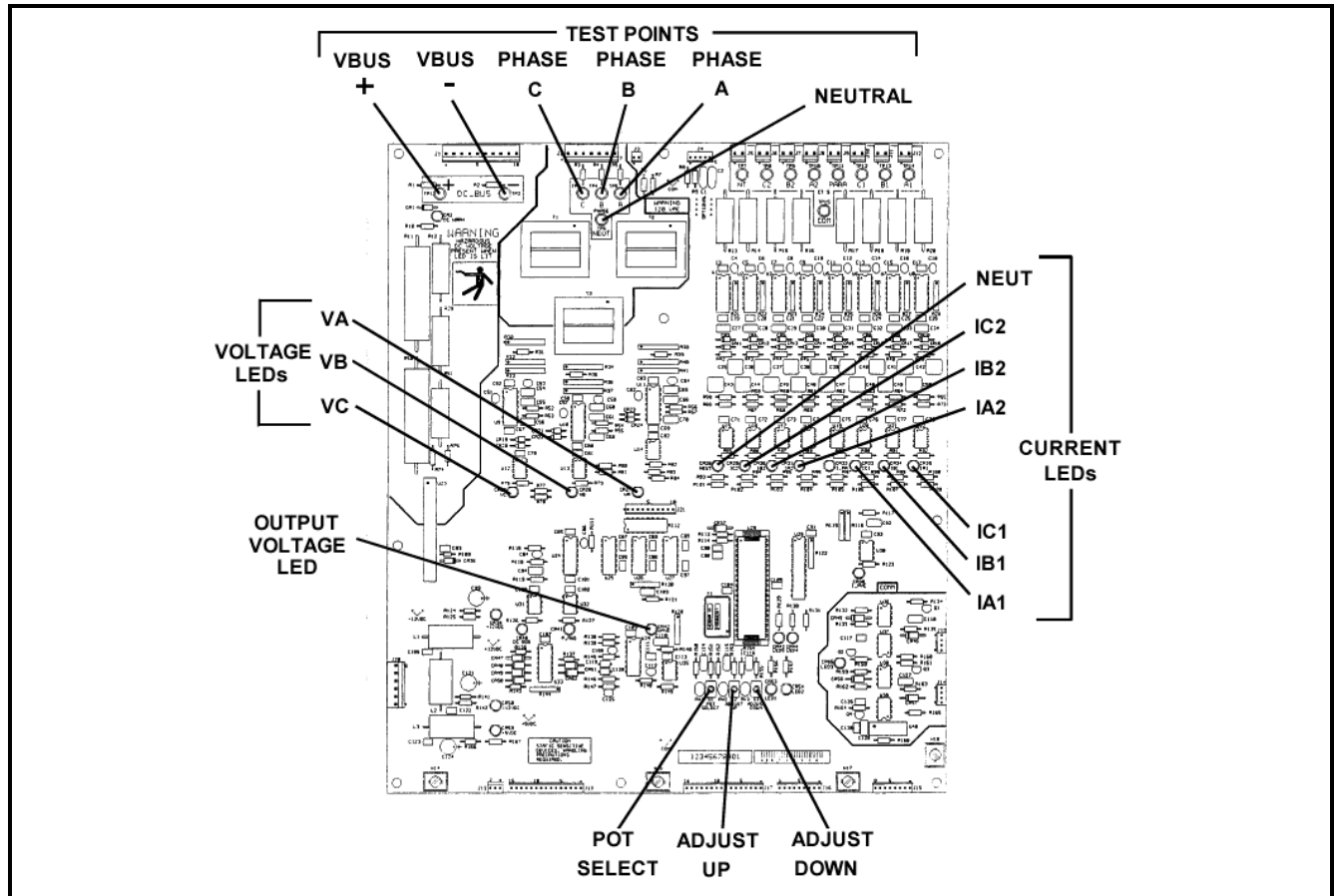

Signal Conditioning Board
Figure 4

- (4) Using a properly calibrated voltage meter, place one voltmeter lead into the NEUTRAL test point and the other lead into the PHASE A test point. Turn on the voltmeter.
- (5) Check that the control panel displays PHASE A using the control panel PHASE SELECT push button if needed. When power is being delivered, the voltage reading on the voltmeter should match the voltage reading on the control panel.
- (6) If the voltmeter and the control panel readings match, PHASE A calibration is complete.
- (7) If the voltmeter and the control panel readings do not match, use the ADJUST UP and ADJUST DOWN buttons until the readings match.
- (8) Repeat the above procedure for PHASE B and PHASE C.
- (9) Press and release the POT SELECT push button repeatedly until the OUTPUT VOLTAGE LED illuminates.
- (10) Check that the control panel displays average voltage using the control panel PHASE SELECT push button. When power is being delivered, the voltage reading on the control panel is the average output voltage from the converter.

- (11) If the output voltage of the converter is the desired value, the output voltage calibration is complete. If the converter output is not the desired value, use the ADJUST UP and the ADJUST DOWN buttons until the readings match.
- (12) When finished performing voltage calibration, press and hold the POT SELECT push button for 3 seconds until all LED's are turned OFF.

b) Current Calibration Procedure

The amperage settings on this converter are calibrated at the factory however on-site adjustments may be made using the following procedure.

To begin the calibration procedure, the converter must be ON and a load must be present. The following calibrations are to be performed on the Signal Conditioning PC board which is located inside the front door. The PC board has a series of LEDs that indicate which signal is being calibrated. The LED's IA1, IB1, and IC1 are used to indicate which current phase A, B, or C for output 1 is being adjusted. The LEDs IA2, IB2, and IC2 are used to indicate which current phase A, B, or C for output 2 is being adjusted.

WARNING

A reliable and accurate ammeter is needed to complete this calibration.

WARNING

High voltages will be present inside the converter cabinet when the unit is on. Exercise extreme caution when taking measurements or FATAL SHOCK may result.

- (1) Turn the converter on, and place a load on converter output.
- (2) Press and hold the POT SELECT push button for 3 seconds until the IA1 LED illuminates. This LED identifies that the PHASE A current for the output can now be calibrated.
- (3) Using a properly calibrated ammeter, measure the current on the PHASE A.
- (4) Check that the control panel displays PHASE A using the PHASE SELECT push button. When power is being delivered, the amperage reading on the control panel should match the amperage reading on the ammeter.
- (5) If the ammeter and the control panel amperage readings match, calibration is complete.
- (6) If the ammeter and the control panel amperage readings do not match, use the ADJUST UP and ADJUST DOWN push buttons to change the control panel reading until both values match.
- (7) Press and release the POT SELECT push button repeatedly until the next desired signal for calibration is indicated.
- (8) Repeat the above procedure for PHASE B and PHASE C.
- (9) When finished performing calibration, Press and hold the POT SELECT push button for 3 seconds until all LED's are turned OFF.

Section 3 Scheduled Maintenance

1) General

The Hobart PoWerMaster ADV Frequency Converter is designed to be as maintenance free as possible. Therefore, there are few maintenance requirements. Field maintenance of the converter should be performed only by qualified service personnel, and should be limited to cleaning and inspection of the unit and its components, as well as, the replacement of lamps and fuses. All servicing and repair work, including testing and calibration, should be referred to the Hobart Ground Power Service Department, to an authorized service shop for Hobart Ground Power equipment, or to qualified electronic technicians.

2) Scheduled Maintenance Procedure

The converter should be cleaned and inspected once every six months or more frequently if operating conditions warrant it. Proceed as follows with cleaning and inspection.

- a) Turn off input power at the source. Make sure that power cannot be inadvertently turned back on.

WARNING

High voltage may be present inside the converter cabinet, even when the unit is off. Exercise extreme caution or **FATAL SHOCK** may result.

WARNING

Before performing any maintenance inside the converter, always make certain that the DC bus is fully discharged. In certain circumstances, such as a failure of the DC bus discharge PC board, the DC bus may not be discharged when the converter shuts down. Several hundred volts may still be present at the bus.

- b) Open the front and rear doors by turning all six latches counterclockwise with an 8 mm Allen wrench. Exercise extreme caution while the doors are open, as high voltages may be present, even when the unit is off.
- c) Test the DC bus with a voltmeter to be sure that it is fully discharged. The bus can be tested using test jacks TP1 and TP2 on the Signal Conditioning PC Board inside the front door. If the bus is not discharged, close the converter door, wait at least 15 minutes and test it again. Do not perform any work inside the converter while the DC bus remains charged.
- d) Carefully clean dust from the interior of the converter by blowing low pressure compressed air into the interior from the bottom of the unit first and then from the top.

WARNING

Wear eye protection and be careful to avoid blowing debris that could cause harm or injury.

- e) Air Filter — Hobart Ground Power Replacement Part No. 283159-003

The air filter helps clean the incoming air to the converter. The air filter must be in place while the converter is in operation. The filter should be inspected regularly for cleanliness

If the filter needs to be cleaned, flush with water. The air filter may also need to be replaced annually.

- f) Clean heat sinks and printed circuit boards using compressed air or a soft brush.
- g) Inspect terminal blocks for evidence of overheating due to loose electrical connections.
- h) Inspect electrical and mechanical connections for tightness. Inspect closely all compression-type connectors.
- i) Inspect printed circuit boards for evidence of overheating, such as burned resistors or capacitors. Note that the printed circuit boards are coated with a fungus and moisture-proof coating which turns brown on hot components. This is a normal occurrence, especially on resistors exceeding 1-watt in rating.
- j) Check and inspect all front panel components, including indicator lamps.
- k) Inspect the long hinge at the front and rear of the unit. If these hinges stick and are difficult to operate, spray hinges with a silicone spray lubricant.
- l) Inspect all wiring, leads, and cables. Inspect for cuts, abrasions, and signs of deterioration and overheating. Inspect leads for broken strands at terminals.
- m) Check to be sure that the fan is operational and does not exhibit excess bearing wear. The unit contains one fan hidden in the center, located behind the Input Control PC Board. Removal of the Input Control and Signal Conditioning PC Boards are required to inspect the fan, as it cannot be seen from either door access.
- n) After inspection has been completed, close and latch the front and rear doors, and turn on input power at the source.

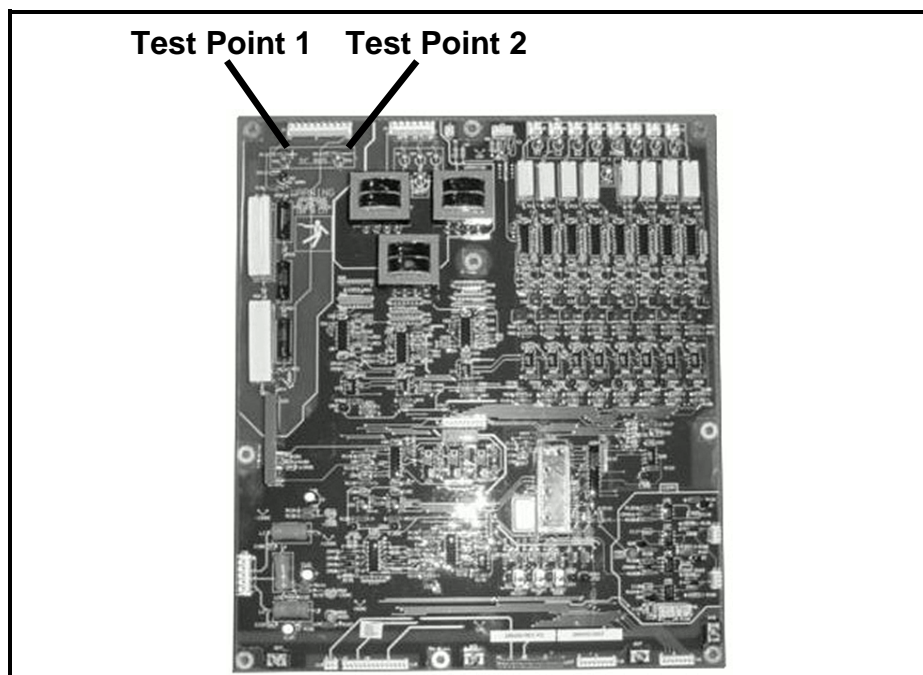

Signal Conditioning Board Tests Points

Figure 1

Chapter 3 Overhaul / Major Repair

Unscheduled Repair

1) General

Repair of the converter will consist primarily of parts replacement. Most of the components used in the converter cannot be disassembled and repaired, and must be replaced if faulty. Additionally, inoperative PC boards cannot be repaired in the field, but must be replaced as a complete unit. PC boards may be returned to the factory for replacement. Contact Hobart Ground Power for parts and replacement instructions.

2) Service Information and Factory Repair

Questions concerning the operation, repair and servicing of this converter should be directed to the Hobart Ground Power Service Department. When making such an inquiry, be sure to provide the service department with the model number, serial number, and approximate date of receipt of the unit. If it is deemed necessary to return the unit to the factory for servicing, contact the service department for authorization. For warranty information, refer to the warranty statement behind the cover page of this manual or contact the Hobart Ground Power Service Department.

When ordering parts from your Hobart Ground Power Supply Department, be sure to include all pertinent information from the converter's identification plate (specification number, model, and unit rating). If you have any questions concerning your Hobart Ground Power equipment, immediately contact our service department by mail, telephone or FAX.

Write:	Hobart Ground Power Service Department 1177 Trade Square East Troy, Ohio 45373 U.S.A.
Call Inside U.S.A.:	(800) 422-4166 (Parts) (800) 422-4177 (Service)
Call From Foreign Countries:	(937) 332-5050 (Parts) (937) 332-5060 (Service)
FAX Inside U.S.A.	(800) 367-4945
FAX From Foreign Countries:	(937) 332-5121
E-Mail :	service@hobartgroundpower.com
Web Page :	www.hobartgroundpower.com

3) Workmanship

Perform all repairs in accordance with good electrical repair practices. All interconnecting lead connections to components must be made with proper wire terminations. Route all leads neatly and secure with wire ties, cable clamps, etc.

This converter was designed to use metric hardware wherever possible. However, some of the purchased components, such as contactors, switches, transformers, etc., may have standard size hardware (SAE). Hobart Ground Power does not recommend the use of standard size tools on metric hardware or vice versa. Where mentioned, use only the hardware sizes reference in this manual.

CAUTION

Use only metric tools to loosen or tighten metric hardware, and likewise, use only standard size tools to loosen or tighten standard (SAE) size hardware. These fundamental practices will help to avoid insufficient tightening and rounding off corners.

CAUTION

Use only the correctly sized hardware when reassembling parts on this converter. The majority of hardware for this unit is metric.

4) Converter Bridge Mount Removal and Installation

If extensive repairs are to be made on the converter, which could be mounted on a trailer or boarding bridge, it is suggested that the converter be removed and placed on a solid supporting structure of some kind to prevent any further damage.

WARNING

High voltages may be present inside the cabinet, even when the unit is off. Exercise extreme caution or **FATAL SHOCK** may result.

WARNING

Before performing any maintenance inside the converter, always make certain that the DC bus is fully discharged. In certain circumstances, such as a failure of the DC bus discharge PC board, the DC bus may not be discharged when the converter shuts down. Several hundred volts may still be present at the bus.

- a) Turn off input power at the source. Make sure that power cannot be inadvertently turned back on.
- b) Open the front door by turning all three latches counterclockwise with an 8 mm Allen wrench.
- c) Test the DC bus with a voltmeter to be sure that it is fully discharged. The bus can be tested using test jacks TP1 and TP2 on the upper left corner of the Signal Conditioning PC Board inside the front door. If the bus is not discharged, close the converter door, wait at least 15 minutes, and test it again. Do not perform any work inside the converter while the DC bus remains charged.
- d) Disconnect the three AC input leads at terminals L1, L2, and L3 from the circuit breaker CB1 and the grounding wire at the grounding lug.
- e) Loosen the clamp in the base and remove the input cable from the clamp.

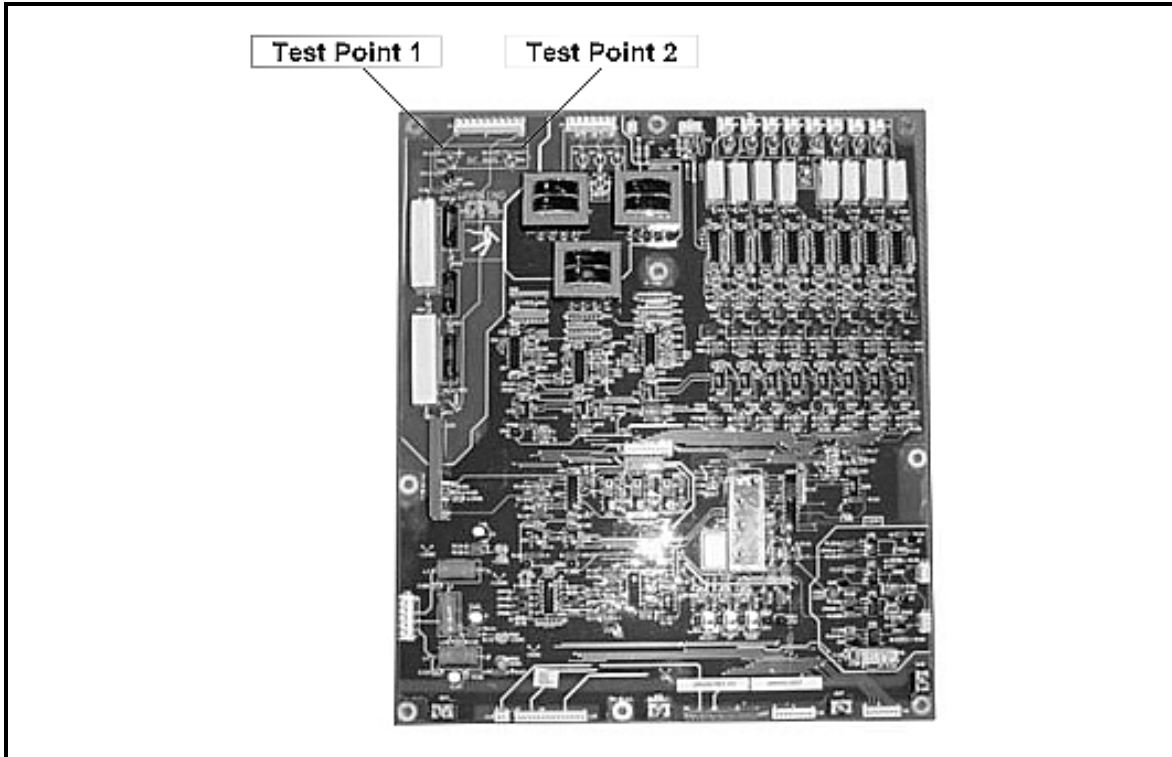

DC Bus Test Points
Signal Conditioning Board (Front Door)
Figure 1

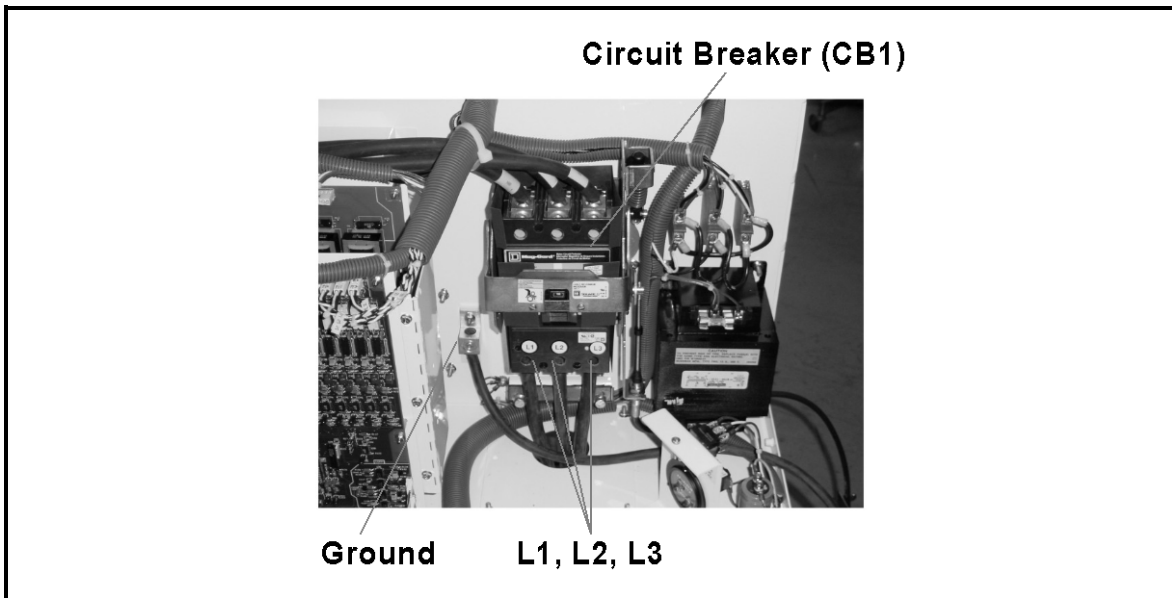

Input Cable Connections
Figure 2

- f) Remove the input cable from the converter.
- g) Close and latch the front door, and open the rear door.
- h) Disconnect the output cables from the output contactors. Disconnect the EF signal and remote control leads from the terminal strips.
- i) Loosen the cable clamp on the bottom panel and remove the output cables from the converter.
- j) Be sure all leads are free and do not become entangled.
- k) Attach a lifting hoist or forklift to the bottom of converter and remove the mounting screws or bolts that attach the converter to its mounting.
- l) Carefully remove the converter.
- m) Move the converter to a clear working area where it can be placed on a solid supporting structure.
- n) Re install in the reverse order of removal. See Chapter 2 for additional information on installing the converter.

5) Component Removal and Replacement

Most of the components in the converter are easily replaced when necessary. Chapter 1 and Chapter 4 show the locations of the components in the converter.

a) Preparation

Before removing or replacing any component, follow these steps:

- (1) Turn off input power at the source. Make sure that power cannot be inadvertently turned back on.

WARNING

High voltages may be present inside the cabinet, even when the unit is off. Exercise extreme caution or **FATAL SHOCK** may result.

WARNING

Before performing any maintenance inside the converter, always make certain that the DC bus is fully discharged. In certain circumstances, such as a failure of the DC bus discharge PC board, the DC bus may not be discharged when the converter shuts down. Several hundred volts may still be present at the bus.

- (2) Open the front door by turning all three latches counterclockwise with an 8 mm Allen wrench.
- (3) Test the DC bus with a voltmeter to be sure that it is fully discharged. The bus can be tested using test jacks TP1 and TP2 on the upper left corner of the Signal Conditioning PC Board inside the front door. If the bus is not discharged, close the converter door, wait at least 15 minutes, and test it again. Do not perform any work inside the converter while the DC bus remains charged.

b) Component Removal and Replacement

(1) DC Electrolytic Capacitors (C14-C19) **[NOTE WARNINGS ABOVE]**

Chapter 1 and Chapter 4 show the location of the capacitor.

- a Open the front door by turning all three latches counterclockwise with an 8 mm Allen wrench.
- b Remove the resistors, four or six depending on the converter configuration, which are connected across the two bus bars that are attached to the capacitors.
- c Remove the bus bars from the capacitor bank.

WARNING

Capacitors are **POLARITY SENSITIVE**. Make certain that capacitors are installed **EXACTLY** as they were previously installed.

- d Remove defective capacitor and replace it.
- e Reinstall is in the reverse order of removal. Make certain that components are installed exactly as they were previously installed and make certain that screws and nuts are tightened securely. The mounting face of each aluminum terminal stud, but not the threads of the capacitors, must be coated with Penetrox or an equivalent anti-oxidation compound.

(2) AC Output Contactors (K1 and K2)

Chapter 1 and Chapter 4 show the location of the contactors.

- a Open the rear door by turning all three latches counterclockwise with an 8 mm Allen wrench.
- b Clearly label each of the leads connected to the contactor and disconnect each one.
- c Loosen, but do not remove, the three screws that hold the contactor in place, then slide up and to the left until the contactor can be removed.
- d Reinstall in the reverse order of removal. If necessary, verify connections by referring to the pertinent connection diagram in Chapter 5.

(3) Control Panel

- a Open the front door by turning all three latches counterclockwise with an 8 mm Allen wrench.
- b The control panel PC board is fastened to the backside of the control panel. Reach in through the door and carefully detach the many leads that are attached to the PC Board.
- c While holding onto the control panel, remove the ten (10) screws that hold the control panel onto the converter.
- d Slowly pull the control panel and PC board out of the unit from the outside.
- e Reinstall in the reverse order of removal. If necessary, verify wiring by referring to the pertinent connection diagram in Chapter 5.

(4) Cooling Fans (B1 and B2)

Access to the middle fan (B1):

- a Open the front door by turning all three latches counterclockwise with an 8 mm Allen wrench.
- b Clearly label each of the leads connected to Input Control PC Board and Signal Conditioning PC Boards then disconnect each one.
- c Remove the air duct plenum panel with the Input Control PC Board and Signal Conditioning PC Boards attached.
- d Remove the screws that hold the fan entrance panel in place.
- e Detach the wiring from the fan.
- f Remove the screws that hold the fan mount panel in place.
- g Carefully pull out the fan and mounting panel.
- h Remove the fan from the mounting panel.
- i Reinstall in the reverse order of removal. If necessary, verify wiring by referring to the pertinent connection diagram in Chapter 5.

Access to the outlet fan (B2):

- a Open the front door by turning all three latches counterclockwise with an 8 mm Allen wrench.
- b Detach the wiring from the fan.
- c Clearly label each of the leads connecting the input cable and leads to the circuit breaker and remove the circuit breaker to gain access to fan mounting screws.
- d Remove the output grill on the side of the converter to gain access to the fan.
- e Remove the screws that hold the fan in place.
- f Carefully pull out the fan.
- g Reinstall in the reverse order of removal. If necessary, verify wiring by referring to the pertinent connection diagram in Chapter 5.

(5) Input SCR/Diode Module (SCR1-SCR6)

Chapter 1 and Chapter 4 show the location of the SCR/diode modules.

- a Open the front door by turning all three latches counterclockwise with an 8 mm Allen wrench.
- b Remove the input SCR/Diode Module using an 8 mm socket, and a Phillips head screw driver.
- c Remove all traces of heat sink pad/material from the heat sink plate.

- d Reinstall in reverse order as shown above. If necessary, verify wiring by referring to the pertinent connection diagram in Chapter 5.

Figure 3 shows the recommended torque values for the rectifier modules used in this converter. Rectifier torque values are shown in inch-pounds (inch-lbs.), Newton-meters (NM), and centimeter-kilograms (cm-kg).

Location	Torque Values		
Case to Heat Sink	44 inch-lbs.	5 NM	51 cm-kg
Terminal, M6 Screws	53 inch-lbs.	6 NM	61 cm-kg

Input Rectifier Torque Requirements
Figure 3

(6) IGBT - Power Modules (PM1-PM12)

Chapter 1 and Chapter 4 show the location of the IGBT's.

- a Open the front door by turning all three latches counterclockwise with an 8 mm Allen wrench.
- b Remove the capacitor bank assembly, in front of the IGBT's, using a 10 mm socket and a Phillips head screwdriver.
- c Remove the IGBTs as needed using a Phillips head screwdriver.
- d Remove all traces of heat sink pad/material from the heat sink plate.
- e Reinstall in reverse order as shown above. If necessary, verify wiring by referring to the pertinent connection diagram in Chapter 5.

Figure 4 of this chapter shows the recommended torque values for the IGBTs. Power module torque values are shown in inch-pounds (inch-lbs.), Newton-meters (NM), and centimeter-kilograms (cm-kg).

Location	Torque Values		
Case to Heat Sink	27 inch-lbs.	3 N-m	31 cm-kg
Terminal, M4 Screws	17 inch-lbs.	1.9 N-m	20 cm-kg
Terminal, M6 Screws	27 inch-lbs.	3 N-m	31 cm-kg

IGBT - Power Module Torque Values
Figure 4

(7) DC Bus Discharge Resistor (R3)

Chapter 1 and Chapter 4 show the location of the resistor.

- a Open the rear door by turning all three latches counterclockwise with an 8 mm Allen wrench.
- b Disconnect the two leads from the resistor.

- c Using a 10 mm wrench, remove the nut, lock washer, and flat washer at the top end of the long threaded bar.
- d Slide the bar out from while holding the resistor to prevent it from falling.
- e Reinstall in the reverse order of removal. If necessary, verify connections by referring to the pertinent connection diagram in Chapter 5.

(8) Door Interlock Switches (S2 and S7)

Chapter 1 and Chapter 4 show the location of the switches.

- a Open the front or rear doors by turning all three latches counterclockwise with an 8 mm Allen wrench.
- b Disconnect the two leads from the switch.
- c Remove the two screws holding the switch to the frame of the converter.
- d Reinstall in the reverse order of removal. If necessary, verify connections by referring to the pertinent connection diagram in Chapter 5.

(9) Heat Sink Thermal Switch (S4)

Chapter 1 and Chapter 4 show the location of the switch. The thermal switch is located on the heat sink beside the power modules, which are behind the DC Capacitors inside the front door.

- a Open the rear door by turning all three latches counterclockwise with an 8 mm Allen wrench.
- b Remove the capacitor bank assembly using a 10 mm socket, and a Phillips head screwdriver.
- c Remove the bus bar located behind the DC capacitors.
- d Disconnect the two leads from the switch.
- e Remove the two small screws on each side of the switch.
- f Reinstall in the reverse order of removal. If necessary, verify connections by referring to the pertinent connection diagram in Chapter 5.

(10) Transformer Thermal Switch (S5)

The main transformer has a thermal switch, tucked in the coils of its windings, that detects over temperature. The thermal switch has two wire leads connected to a terminal strip on the transformer.

- a Carefully pull out the switch that is tucked in the coils of the transformer.
- b Disconnect the thermal switch wire leads from the small terminal strip.
- c Reinstall in the reverse order of removal. If necessary, verify connections by referring to the pertinent connection diagram in Chapter 5.

(11) Main Transformers (T2)

Except for physical damage, it is improbable that the main transformer will fail. In the unlikely event of failure, it is not recommended that attempts be made to remove and replace the transformer in the field. Call the Hobart Ground Power Service Department for assistance.

(12) 12-Pulse Transformer (T3)

Except for physical damage, it is improbable that the input transformer will fail. In the unlikely event of failure, it is not recommended that attempts be made to remove and replace the transformer in the field. Call the Hobart Ground Power Service Department for assistance.

(13) Input Control Transformer (T1)

Chapter 1 and Chapter 4 show the location of the input control transformer.

- a Clearly label each of the leads connected to the control transformer and disconnect each one.
- b Remove the four M10 nuts that attach the control transformer to the cabinet frame.
- c Remove the control transformer.
- d Reinstall in the reverse order of removal. If necessary, verify connections by referring to the pertinent connection diagram in Chapter 5.

6) PC Board Removal and Replacement

The ADV converter has printed circuit boards in various locations inside the converter. The boards are as follows:

- ADV Control PC Board (CTL)
- Driver PC Boards (DRV)
- Modulator PC Board (MOD)
- Bus Discharge PC Board (BDC)
- Input/Output PC Board (IOB)
- Signal Conditioning PC Board (SCB)
- Input Power Control PC Board (IPC)

Before inspecting, removing, or replacing any of the boards, follow these steps:

WARNING

High voltages may be present inside the cabinet, even when the unit is off. Exercise extreme caution or **FATAL SHOCK** may result.

WARNING

Before performing any maintenance inside the converter, always make certain that the DC bus is fully discharged. In certain circumstances, such as a failure of the DC bus discharge PC board, the DC bus may not be discharged when the converter shuts down. Several hundred volts may still be present at the bus.

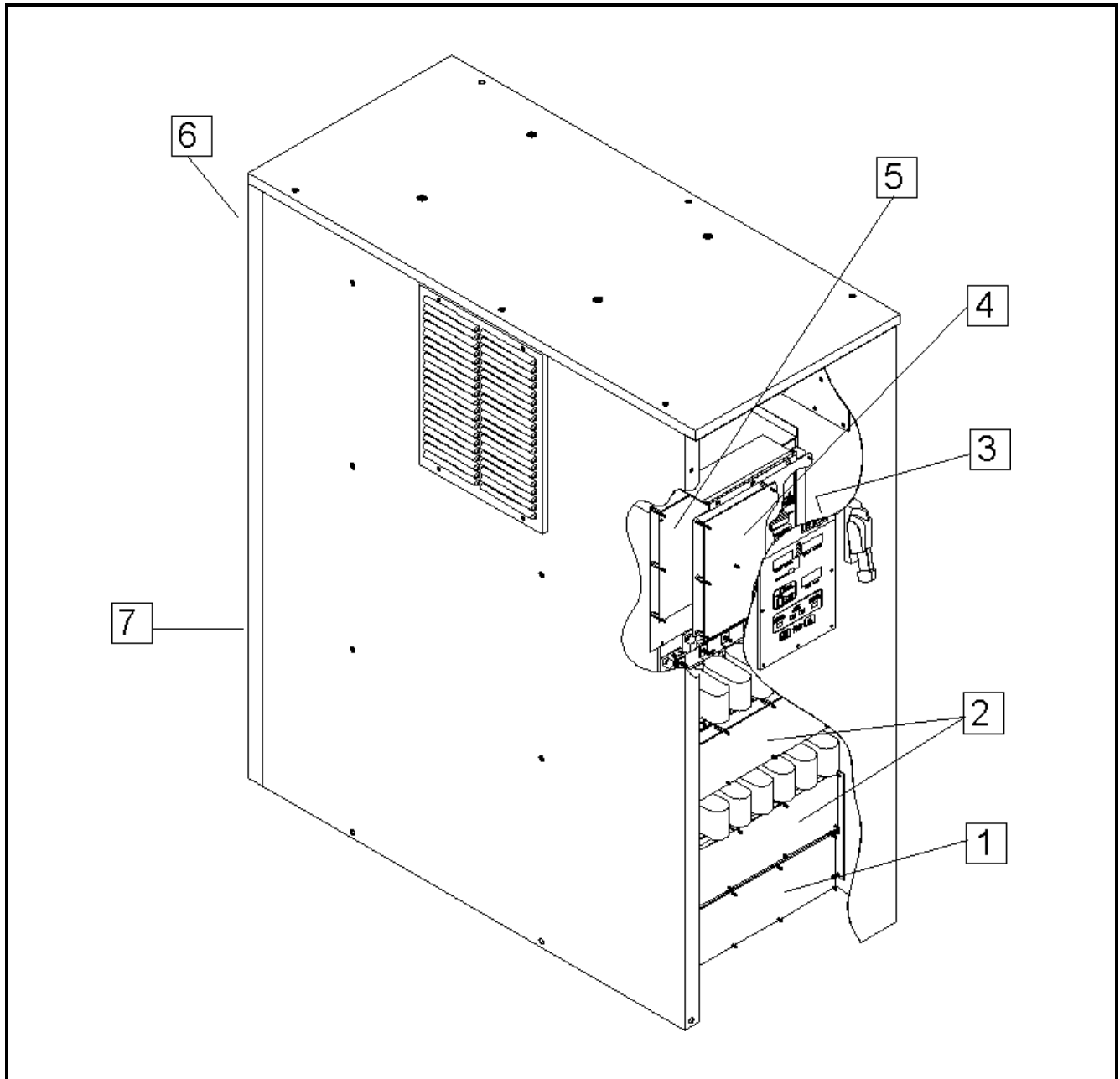

- | | |
|--|--------------------------------|
| 1. Modulator PC Board (A3) | 5. Control PC Board (A2) |
| 2. Driver PC Boards #1 & #2 (A5 & A10) | 6. Input/Output PC Board (A1) |
| 3. Signal Conditioning PC Board (A6) | 7. Bus Discharge PC Board (A7) |
| 4. Input Power Control PC Board (A4) | |

PC Board Locations
Figure 5

- a) Turn off input power at the source. Make sure that power cannot be inadvertently turned back on.
- b) Open the front door by turning all three latches counterclockwise with an 8 mm Allen wrench.
- c) Test the DC bus with a voltmeter to be sure that it is fully discharged. The bus can be tested using test jacks TP1 and TP2 on the upper left corner of the Signal Conditioning PC Board inside the front door. If the bus is not discharged, close the converter door, wait at least 15 minutes, and test it again. Do not perform any work inside the converter while the DC bus remains charged.
- d) Remove and replace each board as follows.

(1) Modulator PC Board (A3)

Chapter 1 and Chapter 4 show the location of the PC board.

- a) Open the front door by turning all three latches counterclockwise with an 8 mm Allen wrench.
- b) Clearly label each of the cables connected to the PC board and then disconnect each one by gently pulling the plug away from the board.

Note: When removing the Modulator PC board, carefully guide it around the adjacent PC board to avoid inadvertent damage to either board.

- c) Steady the board with one hand and remove the eight (8) nuts that hold the board in place.
- d) Reinstall in the reverse order of removal. If necessary, verify connections by referring to the pertinent connection diagram in Chapter 5.

(2) Driver PC Boards (A5 and A10)

Chapter 1 and Chapter 4 show the location of the PC board.

To remove and replace this board, follow these steps:

- a) Open the front door by turning all three latches counterclockwise with an 8 mm Allen wrench.
- b) Clearly label each of the cables connected to the PC board and then disconnect each one by gently pulling the plug away from the board.
- c) Steady the board with one hand and remove the eight (8) nuts that hold the board in place.
- d) Reinstall in the reverse order of removal. If necessary, verify connections by referring to the pertinent connection diagram in Chapter 5.

(3) Signal Conditioning PC Board (A6)

Chapter 1 and Chapter 4 show the location of the PC board.

- a) Open the front door by turning all three latches counterclockwise with an 8 mm Allen wrench.
- b) Clearly label each of the cables connected to the PC board and then disconnect each one by gently pulling the plug away from the board.

- c Steady the board with one hand and remove the nine (9) nuts that hold the board in place.
- d Reinstall in the reverse order of removal. If necessary, verify connections by referring to the pertinent connection diagram in Chapter 5.

(4) Input Power Control PC Board (A4)

Chapter 1 and Chapter 4 show the location of the PC board.

- a Open the front door by turning all three latches counterclockwise with an 8 mm allen wrench.
- b Remove the 8 mm screw that fastens down the hinged Signal Conditioning PC Board panel. Swing the Signal Conditioning PC Board panel out of the way. **DO NOT REMOVE THIS BOARD.**
- c Clearly label each of the cables connected to the PC board and then disconnect each one by gently pulling the plug away from the board.
- d Steady the board with one hand and remove the nine (9) nuts that hold the board in place.
- e Reinstall in the reverse order of removal. If necessary, verify connections by referring to the pertinent connection diagram in Chapter 5.

(5) ADV Control PC Board (A2)

Chapter 1 and Chapter 4 show the location of the PC board.

- a Open the front door by turning all three latches counterclockwise with an 8 mm Allen wrench.
- b Reach in through the door. Clearly label each of the cables connected to the PC Board and then disconnect each one by gently pulling the plug away from the board.
- c While holding onto the control panel, remove the ten (10) screws that hold the control panel onto the front of the unit.
- d Carefully remove the control panel, with PC Board attached, from the converter.
- e Steady the assembly on a smooth clean surface, and remove the six (6) screws that secure the two pieces together.
- f Reinstall in the reverse order of removal. If necessary, verify connections by referring to the pertinent connection diagram in Chapter 5.

(6) Input/Output (I/O) PC Board (A1)

Chapter 1 and Chapter 4 show the location of the PC board.

- a Open the rear door by turning all three latches counterclockwise with an 8 mm Allen wrench.
- b Clearly label each of the cables connected to the PC board and then disconnect each one by gently pulling the plug away from the board.
- c Steady the board with one hand and remove the seven (7) nuts that hold the board in place.

- d Reinstall in the reverse order of removal. If necessary, verify connections by referring to the pertinent connection diagram in Chapter 5.

(7) DC Bus Discharge PC Board (A7)

Chapter 1 and Chapter 4 show the location of the PC board.

- a Open the rear door by turning all three latches counterclockwise with an 8 mm Allen wrench.
- b Clearly label each of the cables connected to the PC board and then disconnect each one by gently pulling the plug away from the board.
- c Steady the board with one hand and remove the four (4) nuts that hold the board in place.
- d Reinstall in the reverse order of removal. If necessary, verify connections by referring to the pertinent connection diagram in Chapter 5.

This page intentionally left blank.

Chapter 4 Illustrated Parts List

Section 1 Introduction

1) General

The illustrated parts list identifies, describes, and illustrates main assemblies, subassemblies, and detail parts of the 400 Hz Solid State Converter manufactured by Hobart Ground Power Division, Troy, Ohio, USA..

2) Purpose

The purpose of this list is to provide parts identification and descriptive information to maintenance and provisioning personnel for use in provisioning, requisitioning, purchasing, storing, and issuing of spare parts.

3) Arrangement

Chapter 4 is arranged as follows:

Section 1 - Introduction
Section 2 - Manufacturer's Codes
Section 3 - Parts List
Section 4 - Numerical index

4) Explanation of Parts List

a) Contents

The parts list contains a breakdown of the equipment into assemblies, subassemblies, and detail parts. All parts of the equipment are listed except:

- (1) Standard hardware items (attaching parts) such as nuts, screws, washers, etc., which are available commercially.
- (2) Bulk items such as wire, cable, sleeving, tubing, etc., which are commercially available.
- (3) Permanently attached parts, which lose their identity by being welded, soldered, riveted, etc., to other parts, weldments, or assemblies.

b) Parts List Form

This form is divided into six columns. Beginning at the left side of the form and proceeding to the right, columns are identified as follows:

- (1) FIGURE-ITEM NO. Column

This column lists the figure numbers of the illustration applicable to a particular parts list and also identifies each part in the list by an item number. These item numbers also appear on the illustration. Each item number on an illustration is connected to the part to which it pertains by a leader line. Thus the figure and item numbering system ties the parts lists to the illustrations and

vice-versa. The figure and index numbers are also used in the numerical index to assist the user in finding the illustration of a part when the part number is known.

(2) HOBART PART NUMBER Column

All part numbers appearing in this column are Hobart part numbers. In all instances where the part is a purchased item, the vendor's identifying five-digit code and his part number will appear in the "NOMENCLATURE" column. Vendor parts, which are modified by Hobart, will be identified as such in the "NOMENCLATURE" column. In case Hobart does not have an identifying part number for a purchased part, the "HOBART PART NUMBER" column will reflect "No Number" and the vendor's number will be shown in the "NOMENCLATURE" column. Parts manufactured by Hobart will reflect no vendor or part number in the "NOMENCLATURE" column.

(3) NOMENCLATURE Column

The item identifying name appears in this column. The indented method is used to indicate item relationship. Thus, components of an assembly are listed directly below the assembly and indented one space. Vendor codes and part numbers for purchased parts are also listed in this column when applicable.

(4) EFF (Effective) Column

This column is used to indicate the applicability of parts to different models of equipment. When more than one model of equipment is covered by a parts list, there are some parts that are used on only one model. This column is used for insertion of a code letter A, B, etc., to indicate these parts and to identify the particular model they are used on.

This manual covers only one model, so the EFF column is not used. All parts are usable on this model, Part Number 500048B-52220.

(5) UNITS PER ASSEMBLY Column

This column indicates the quantity of parts required for an assembly or subassembly in which the part appears. This column does not necessarily reflect the total used in the complete end item.

Section 2 Manufacturer's Codes

1) Explanation of Manufacturer's (Vendor) Code List

The following list is a compilation of vendor codes with names and addresses for suppliers of purchased parts listed in this publication. The codes are in accordance with the Federal Supply Codes for Manufacturer's Cataloging Handbook H4-1, (CAGE CODES) and are arranged in numerical order. Vendor codes are inserted in the nomenclature column of the parts list directly following the item name and description. If a manufacturer does not have a code, the manufacturer's full name is listed in the nomenclature column.

Code	Vendor's Name and Address	Code	Vendor's Name and Address
D0024	Semikron International Sigmundstrasse 200 P.O. Box 820251 Nuerengerg, Germany 90253	05YB3	Acon Inc. 22 Bristol Dr. South Easton, MA 02375-1108
E0615	Kraus and Naimer 42 Miramar Avenue P.O. Box 15-009 Wellington, New Zealand	05HB5	Magnecomp Inc. 161 Eagles Nest Dr Pickens, SC 29671-7808
S7023	Bossard LTD Fasteners Steinhauserstrasse 70 Zug, Switzerland, CH-6300	00779	Tyco Electronics (Amp) 2800 Fulling Mill Rd Bldg-38 Middletown, PA 17057 - 3142
0E8J0	Emka Inc. 1961 Fulling Mill Rd. Middletown, PA 17057-3125	01428	Tuthill Corporation DBA Tuthill Controls Group 2110 Summit St. New Haven, IN 46774-9524
OMR72	Henkel Corp 26941 Cablot Rd, Suite 124 Laguna Hills, CA 92653-7007	02660	Amphenol Corp. Spectra-Strip/ltd 40-60 Delaware Ave SIDNEY, NY 13838 - 1395
0CYC7	Western Rubber & Supply 7888 Marathon Dr Ste Livermore, CA 94550 - 9314	02768	Illinois Tool Works Inc. Fastex Division 195 S. Algonguin Rd. Des Plaines, IL 60016-6197
0HZP9	Diesel Radiator Co. 1985 Janice Ave. Melrose Park, IL 60160-1008	02929	Newark Electronics Div 4801 N Ravenswood Ave Chicago, IL 60640 - 4457
0TSE6	Infineon Technologies Industrial Power Inc. 1050 US HWY 22 Lebanon, NJ 08833-4208	1AA44	Collmer Semiconductor Inc.. 2542 Highlander Wa Carrollton, TX 75006
01XD4	Contact Industries Inc 25 Lex-Industrial Dr Mansfield OH 44903 - 8699	1SPJ9	Hobart Ground Power 1177 Trade Road East Troy, OH 45373

Code	Vendor's Name and Address	Code	Vendor's Name and Address
1W134	Eaton Corp. 4201 N. 27 TH St Milwaukee, WI 53216-1897	2N562	Power Transmission Sales Inc. 531 Washington P.O. Box 229 Chagrin Falls, OH 44022-0229
1DG36	Phillips And Temro Industries Inc E. M. Products Inc. 5380 Cottonwood Ln Prior Lake, MN 55372	23803	N T N Bearing Corp of America 191 Sheree Blvd Ste 101 Exton PA 19341-1265
1DL99	Fleetguard Inc. Div. of Cummins Engine Company 311 N. Park Street Lake Mills, IA 50450 - 1299	24161	Gates Corporation 900 S Broadway Denver CO 80217-5887
1E045	Austin Hardware and Supply Co. 950 Northwest Technology Dr Lees Summit, MO 64086 - 5692	24446	General Electric Co. 3135 Easton Tpke. Fairfield, CT 06431
12662	Peterson Mfg Co. 4200 E 135th St Grandview MO 64030-2896	25710	Deka Plastics Inc. 914 Westfield Ave. Elizabeth, NJ 07208-1222
13445	Cole-Herse 20 Old Colony Ave. Boston, MA 02127-2405	27410	Harris Corp. 1025 W NASA Blvd. Melbourne, FL 32901
14552	Microsemi Corporation 2381 MORSE AVE Irvine, CA 92614-6233	28520	Heyco Inc. 1800 Industrial Way N. Toms River, NJ 08755-4809
14799	Square D Company, Inc Dba Schneider Electric 9522 W. Winona Schiller Park, IL 60176-1084	3A054	McMaster Carr Supply Co. 9630 Norwalk Blvd. Santa Fe Springs, CA 90670-2932
16476	Maxima Technologies & Systems Llc 1811 Rohrerstown Rd Lancaster, PA 17601-2321	3Y208	Taylor And Summerville Battery Co 3485 Successful Way Dayton Oh 45414-4319
18265	Donaldson Company Inc. DBA Torit Products 1400 W. 94th St. Minneapolis, MN 55431-2370	30104	Automotive Controls Corp. 1300 W. Oak St. P.O. Box 788 Independence, KS 67301-0788
2B428	MJO Industries Inc. DBA Hughes-Peters 8000 Technology Blvd. Huber Heights, OH 45424 - 1573	30430	Marathon Electric Mfg. Corp. 398 Beach Rd. Burlingame, CA 94010-2004
2B664	All-Phase Electric Supply Co 1620 W Main St P.O. Box 149 Springfield OH 45501-0149	38151	Marathon Electric Mfg. Co. 100 E. Randolph St. Wausau, WI 54401-2568
		39TH9	Motion Industries Inc. 8580 Industry Park Dr. Piqua, OH 45356-8535

Code	Vendor's Name and Address	Code	Vendor's Name and Address
40121	Peterson Mfg. Co. Inc. 700 W. 143rd St. Plainfield, IL 60544-9733	57733	Stewart-Warner Corporation 333 Ludlow St Stamford, CT 06902-6987
44655	Heico Ohmite LLC 1600 GOLF RD 850 ROLLING MEADOWS, IL 60008 - 4204	59656	Dean Technology Inc. DBA CKE 1000 Lucerne Road Lucernemines, PA 15754-0211
46922	Crawford Electric Co 445 E 32 Mile Rd Romeo MI 48065-5270	6S553	Wes-Garde Components Group Inc 300 Enterprise Dr Westerville, OH 43081-8840
49234	Protectoseal Company 225 W Foster Ave Bensenville, IL 60106-1631	6Y440	Micron Technologies Inc. 8000 S. Federal Way Boise, ID 83716-7128
5N8K3	Alpha Devices 11963 Abbey Rd. Cleveland, OH 44133	60038	Timken Corporation 1835 Dueber Ave Sw Canton, OH 44706-2728
5P059	Tech Products Corp. 2215 Lyons Rd Miamisburg, OH 45342 - 4465	61706	EAO Switch Corporation 98 Washington St. Milford, CT 06460-3133
50508	Magnetic Components Inc. 9520 Ainslie St. Schiller Park, IL 60176-1191	62292	EBM Industries Inc. 110 Hyde Rd. P.O. Box 4009 Farmington, CT 06034-4009
52793	Saginaw Products Corp. DBA CIGNYS 68 Williamson St. Saginaw, MI 48601-3246	66180	Automatic Timing and Controls 3312 Bloomingdale Melrose Park, IL 60160-1030
54646	Clampco Products Inc. 1743 Wall Road Wadsworth, OH 44281-9558	66844	Powerex Inc. 173 PAVILION LN Youngwood, PA 15697-1800
55752	Parker Hannifin Corp. DBA Racor Div. 3400 Finch Rd. Modesto, CA 95354-4125	7M613	Wright F.B. Co. of Cincinnati 4689 Ashley Dr. Hamilton, OH 45011-9706
56289	Sprague Electric Company 678 Main St Sanford, MA, 04073-7003	71382	Seal Master Bearings Sub Of Emerson Electric Co. 1901 Bilter Rd. Aurora, IL 60502-9704
57330	Remke Industries Inc. 310 Chadick Drive Wheeling, IL 60090-6039	71400	Cooper Bussmann Inc. 114 Old State Road Ellisville, MO 63021-5942
57347	Wall Industries Inc. 5 Watson Brook Rd. Exeter, NH 03833-4589	72619	Dialight Corporation 1501 State Rte 34 S Farmingdale, NJ 07727-3932

Code	Vendor's Name and Address	Code	Vendor's Name and Address
74400	Hobbs Corporation 1034 E ASH ST Spring Valley, IL 62703-3551	86797	Rogan Corp 3455 Woodhead Dr. Northbrook, IL 60062-1812
74542	Hoyt Electrical Instruments 23 Meter ST. Concord, NH 03303-1894	9Y826	Marsh Electronics Inc. 1563 S. 101st St. Milwaukee, WI 53214-4032
74545	Hubbell Inc Wiring Device Div 185 Plains Road Milford, CT 06460	91637	Vishay Dale Electronics Inc. 1122 23RD St. Columbus, NE 68601-3647
74829	Ilsco Corp. 4730 Madison Rd. Cincinnati, OH 45227-1426	91929	Honeywell International Inc. DBA Honeywell 11 W. Spring St. Freeport, IL 61032-4316
75418	Kysor Industrial Corporation 1 Madison Ave Cadillac, Michigan 49601-9784	94222	Southco Inc. 210 N. Brinton Lake Rd. Concordville, PA 19331
75915	Littelfuse, Inc. 8755 W Higgins Road Ste 500 Chicago, IL 60631 - 2701	97520	Basler Electric Company Route 143 Highland, IL 62249-1074
77342	TYCO Electronics Corporation 8010 Piedmont Triad Pkwy Greensboro, NC 27409		
78388	Woodward Controls Inc. 6250 W Howard St Niles, IL 60714-3433		
8A334	Cummins Bridgeway LLC 2297 SW Blvd Ste K Grove City, OH 43123-1822		
8T246	Whitesell RO & Associates, Inc. 7009 CORPORATE WAY Dayton, OH 45459-4238		
81483	International Rectifier Corp 233 Kansas St. El Segundo, CA 90245		
81703	Mulberry Metal Products Inc. 2199 Stanley Terrace Union, NJ 07083-4399		
82866	Research Products Corp. P.O. Box 1467 1015 E. Washington Ave. Madison, WI 53701		

Section 3 Illustrated Parts List

1) Explanation of Parts List Arrangement

The parts list is arranged so that the illustration will appear on a left-hand page and the applicable parts list will appear on the opposite right-hand page. Unless the list is unusually long, the user will be able to look at the illustration and read the parts list without turning a page.

2) Symbols and Abbreviations

The following is a list of symbols and abbreviations used in the parts list:

*	-	Item not illustrated
#	-	Number or Part Number
A, or AMP	-	Ampere
AC	-	Alternating current
AR	-	As required
DC	-	Direct current
Fig.	-	Figure
hd.	-	Head
hex	-	Hexagon
Hz	-	Hertz (cycles-per-second)
I.D.	-	Inside diameter
IN	-	Inch
KVA	-	Kilovolt-ampere
uF	-	Microfarad
No.	-	Number
NHA	-	Next higher assembly
PRV	-	Peak reverse voltage
PSI	-	Pounds per square inch
Ref	-	Reference (the item has been listed previously)
RH	-	Right Hand
LH	-	Left Hand
TM	-	Technical Manual
T-R	-	Transformer-rectifier
V	-	Volt or used as a prefix indicating vendor code

NOTE: An item which does not reflect an index number is an assembly which is not illustrated in it's assembled state, or it is similar (right-hand, left-hand, top, etc.) to an item which is illustrated.

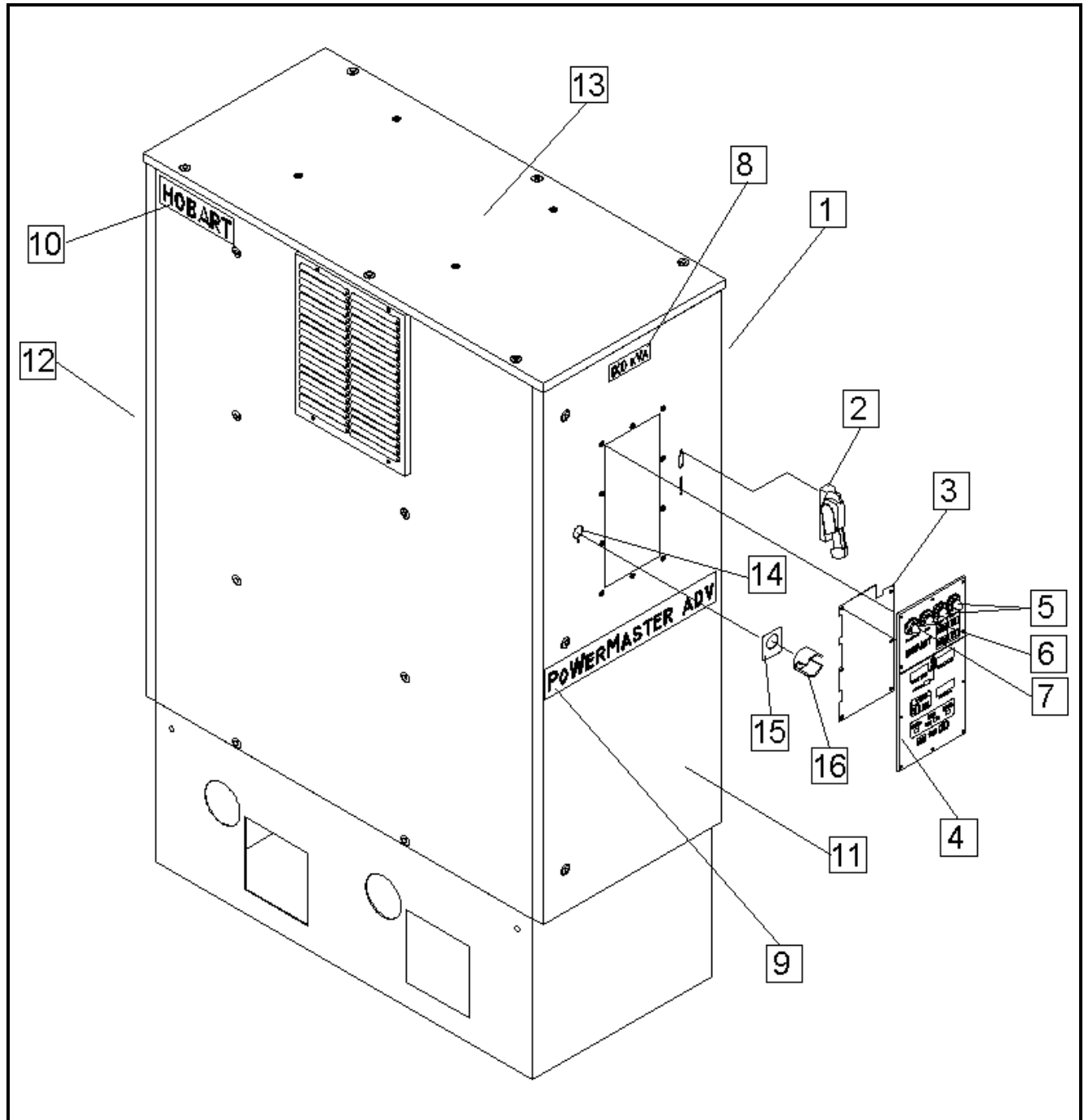

PoWerMaster ADV Converter
Figure 1

FIGURE ITEM NO.	HOBART PART NO.	NOMENCLATURE	EFF	UNIT PER ASSY.
1 -	1	Frame Assembly (See Figure 2)		Ref.
	2	286416-001		1
	3	286411		1
	4	286398-002		1
		286580-001		1
	5	82B1066-012		2
*		400613-004		2
	6	82B1066-001		1
*		400613-004		1
	7	82B1066-010		1
*		400613-004		1
	8	283714-007		1
	9	286457		1
	10	402987		1
	11	Front Interior Components (See Figure 3)		Ref.
	12	Rear Interior Components (See Figure 5)		Ref.
	13	Canopy Components (See Figure 10)		Ref.
	14	286544		1
*	15	288300		1
*		77A1157		1
*		287850		1
	16	285125		1
		...Guard, Mushroom Button (V2B664 #K56YM)		1
		...Relay components (see Figure 5)		Ref.
		Labels		Ref.
*	17	283716		1
		Label, Nameplate, Identification		
*	18	287460		2
*	19	286441		2
*	20	286377		1
*	21	286442		1
*	22	288258		1
		Label, Instructions (Base Plate Cover)		
*	23	288730		1
		Label, Fuse Chart		
		Wires and Cables		Ref.
*	24	287341		1
		Wiring Harness Assembly		
*	25	287858		1
		Harness, Wire, 160SX200		
*	26	286475-006		1
		Cable Chart, ADV, 120-160 KVA		
*	27	286475-007		1
		Cable Chart, ADV, 120-160 KVA 12-pulse option		

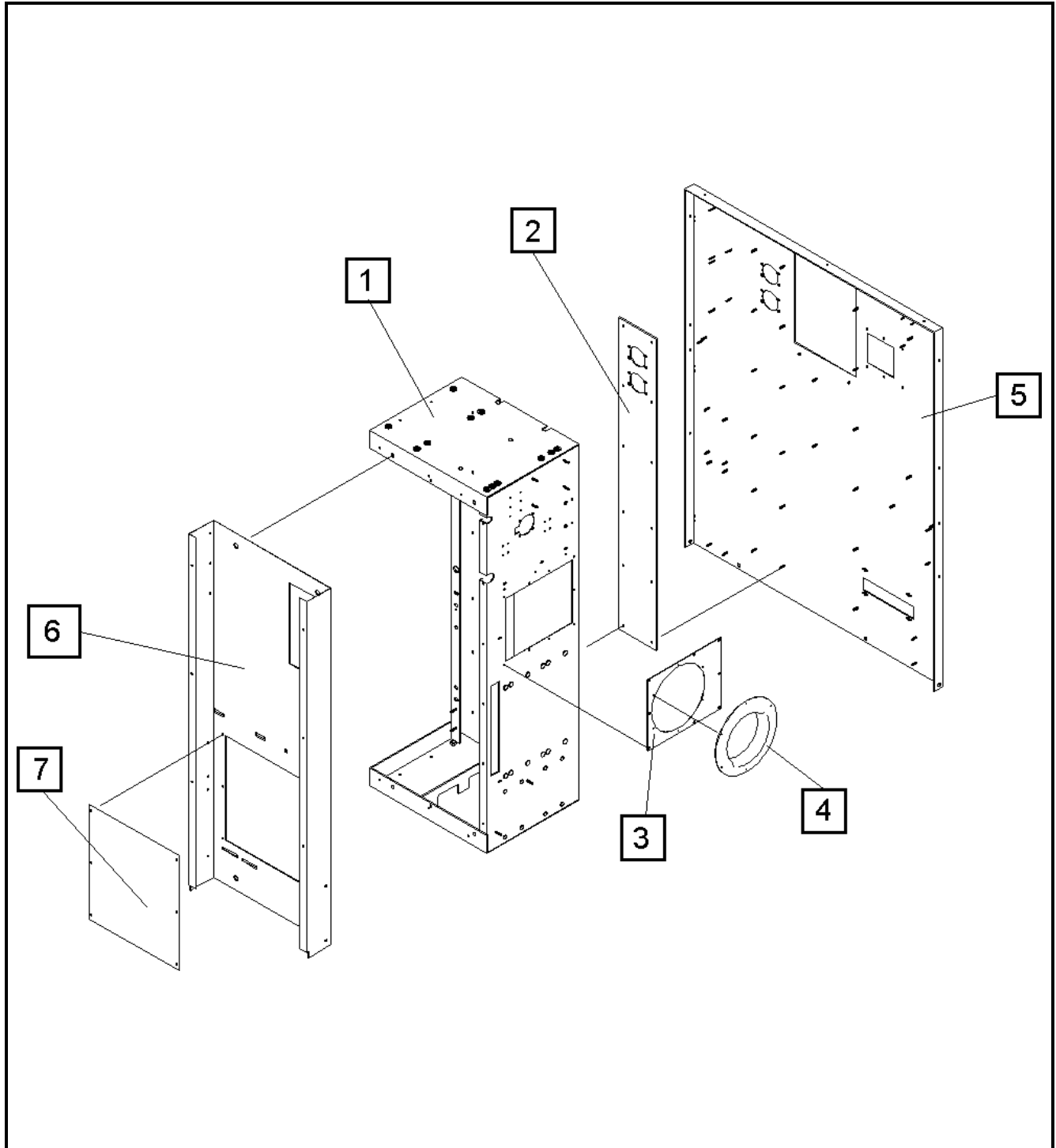

Frame Assembly
Figure 2

FIGURE ITEM NO.	HOBART PART NO.	NOMENCLATURE	EFF	UNIT PER ASSY.
2 -	1	286535		1
	2	286354		1
	3	286376		1
	4	283157-003	Impeller Inlet Ring (V62292 #9621-2-4013)	1
	5	286563	Right Side Panel	1
	6	286577		1
	7	286555		1
*		283171-002		4
*		280936		8

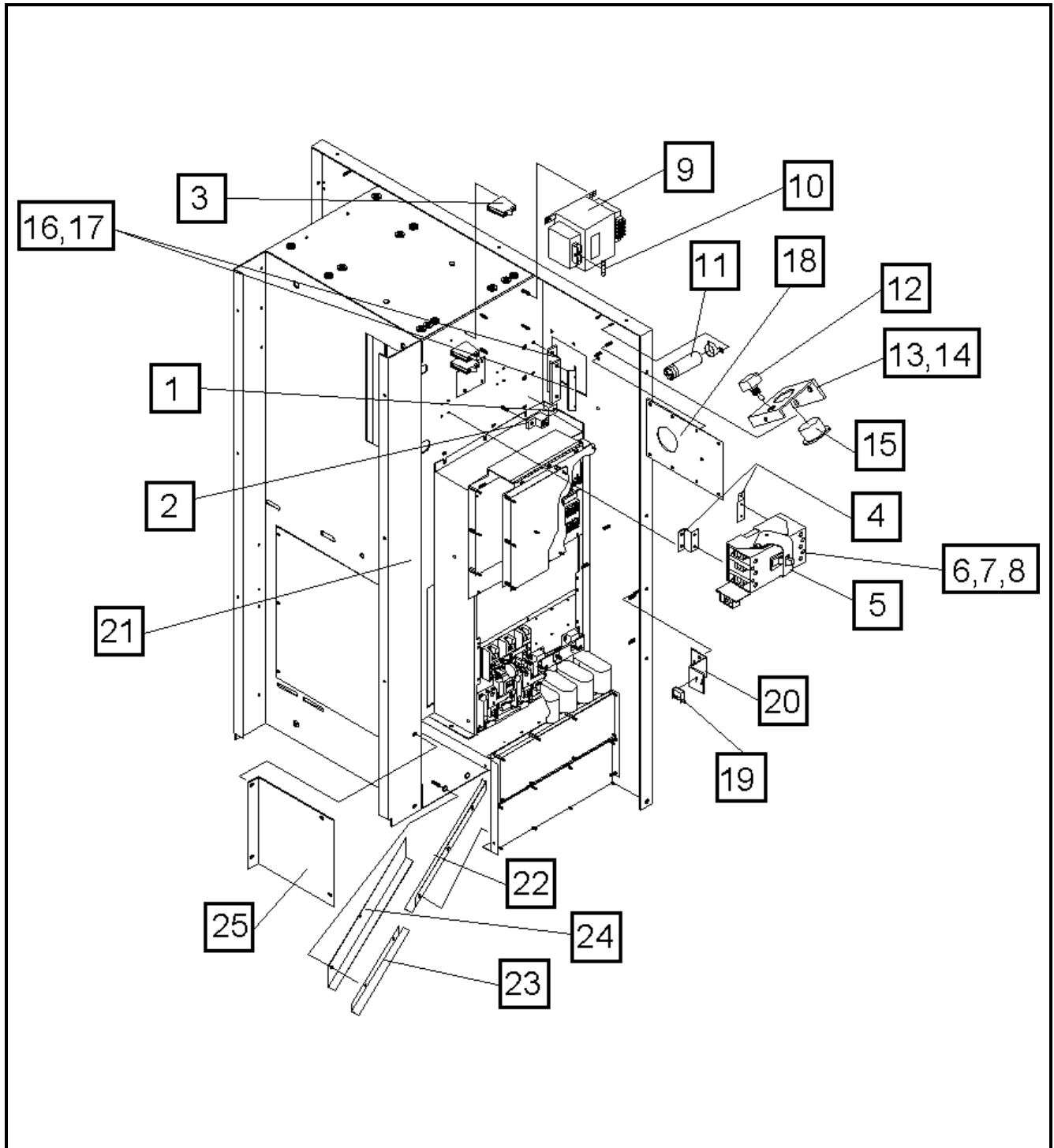

Front Interior Components
Figure 3

FIGURE ITEM NO.	HOBART PART NO.	NOMENCLATURE	EFF	UNIT PER ASSY.
3 -	1	280807		1
	2	285104-001		1
	3	285315-001	M.O.V. Suppressor (V27410 #V661DA40)	3
	4	291139	Circuit Breaker Support	2
	5	291269-003	Circuit Breaker (V14799 #JL36250M75SA)	1
*	291268-002	...Actuator, Circuit Breaker (V14799 # 9422 CSF30)		1
	6	83A1114	Label, L3	1
	7	83A1113	Label, L2	1
	8	83A1112	Label, L1	1
	9	404960-034	Control Transformer, 115 V (V6Y440 #B750-1213-1)	1
	10	W10502-031	Fuse, SB, 15A, 500V (V2B664 #FNQ-15A)	1
	11	281848-002	Capacitor, 1800 UF, 250 VDC	1
	12	402682	Toggle Switch (V5U553 #HLA-271-78)	1
	13	286447	Voltage Selection Label	1
	14	286448	Meter Support Bracket	1
	15	181358	Hour Meter (V6H359 #80001)	1
	16	287856	Cable Clamp Support	1
	17	285568	Cable Clamp Bracket	1
	18	286423	Input Cable Plate	1
*	286585	...Cable Inlet Gasket		1
	19	280673	Door Interlock Switch (V1W134 #SSI2ET10-20Y3)	1
	20	286602	Front Door Switch Support	1
	21		Heatsink Panel Assembly, (See Figure 4)	Ref.
	22	286420	Right Hand Input Filter Guide	1
	23	287841	Left Hand Input Filter Guide	1
	24	286566	Filter Guide	1
	25	286568	Inlet Duct Cover	1
*	26	286557	SCD PCB Latch	1
*	27	286569	Bracket, Driver Board	2
*	28	287835	Plate, Driver Board	1

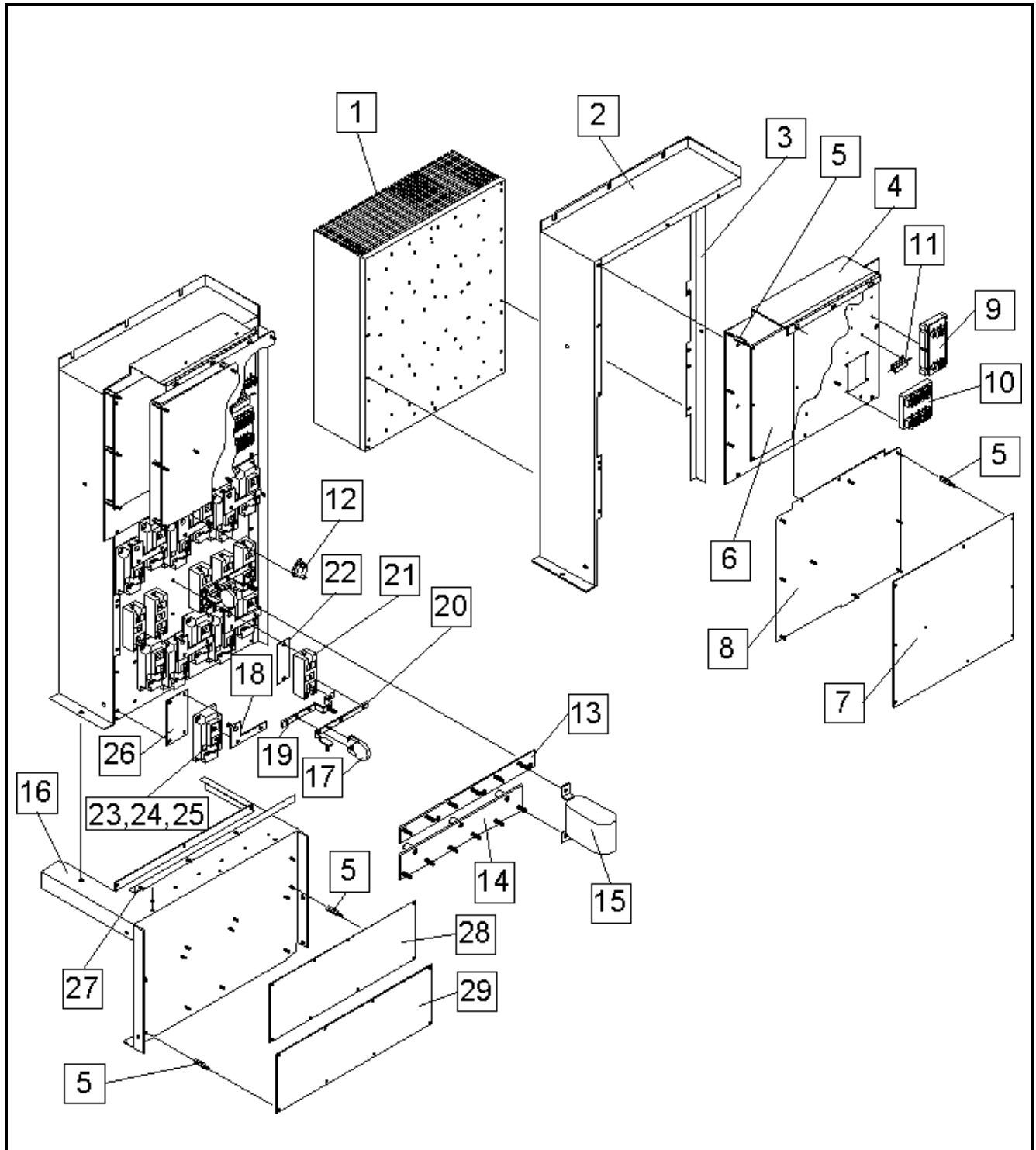

Heat Sink Panel Assembly
Figure 4

FIGURE ITEM NO.	HOBART PART NO.	NOMENCLATURE	EFF	UNIT PER ASSY.
4 -	1	287832		1
	2	287844		1
	3	287843		1
	4	287833		1
	5	284316-002		34
	6	286246B		1
	7	286400A		1
		192266-001		1
	8	286443		1
	9	286528A		1
	10	286367-001		1
	11	286482-001		1
	12	404044-004		1
*	13	287825		2
		402674-002		2
	14	287826		2
		402674-001		2
	15	286389-001		12
	16	286533		1
*	17	403955-021		2
	18	287824		6
	19	287830		2
*	20	287831		2
	21	286285-001		6
*	22	286394		2
	23	283196-003		6
	24	407970		12
	25	285170		12
	26	283867-005		12
	27	283196-002		12
	28	286274		1
	29	286144		2
	30	287353A		1
*	31	77A1109		1
*	32	77A1108		1
*	33	77A1107		1

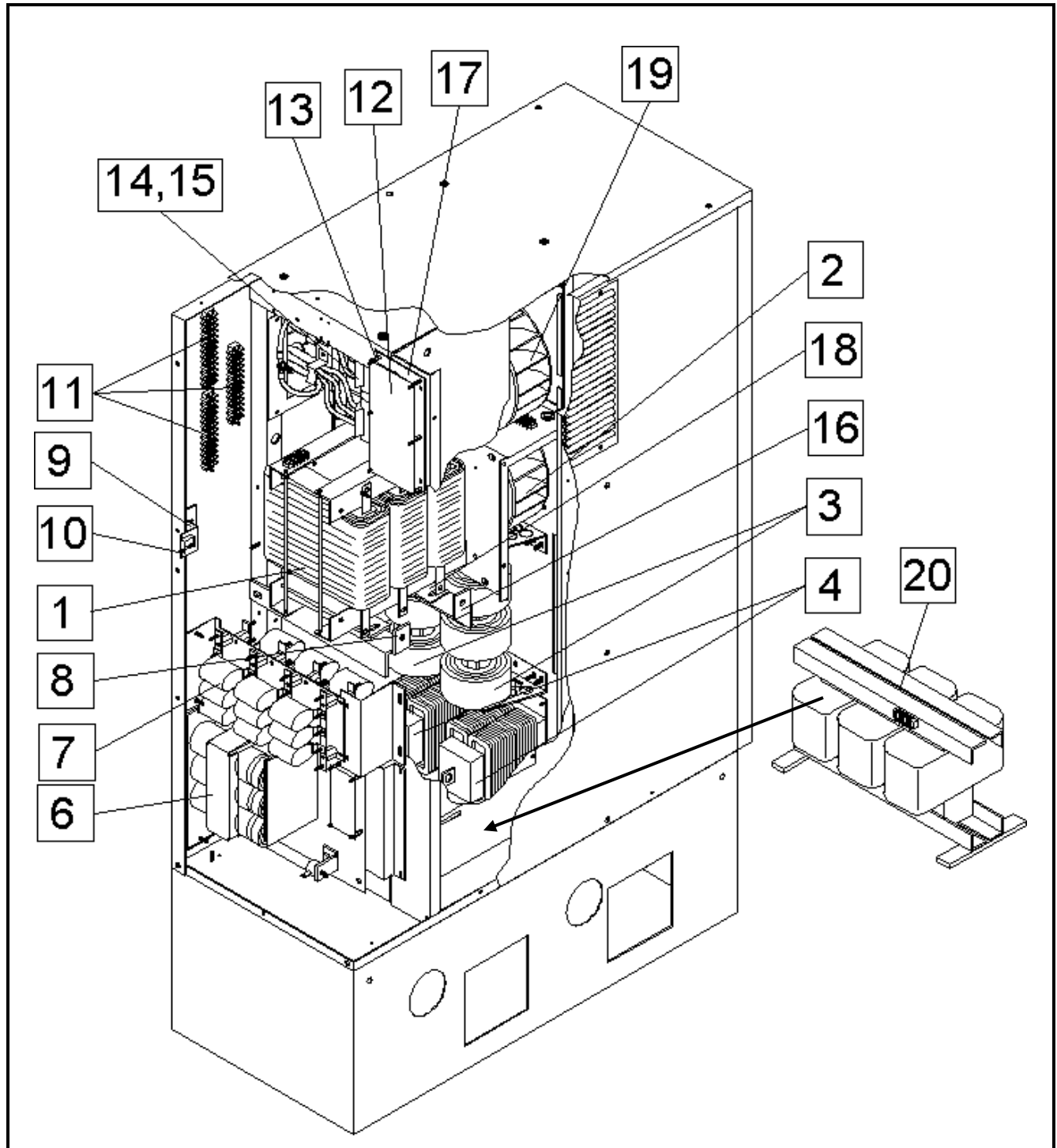

Rear Interior Components
Figure 5

FIGURE ITEM NO.	HOBART PART NO.	NOMENCLATURE	EFF	UNIT PER ASSY.
5 -	1	286480-003		1
*		281971-010		1
*		286449		1
*		286438		4
*		286316-001		4
		286571		4
	2	Fan #1 (See Figure 6)		Ref.
	3	286492-001		2
	4	493712		2
*	5	289751		2
	6	DC Electrolytic Capacitor Assembly (See Figure 7)		Ref.
	7	AC Capacitor Assembly (See Figure 8)		Ref.
	8	286570-001		1
	9	286602		1
	10	280673		1
*	11	283066-002		3
*		286380		1
*		286382		1
*		286531-001		2
*		288974		2
	12	286392-001		1
		16DA4252-037		1
	13	284316-002		6
*	14	AC Contactors (See Figure 9)		Ref.
*	15	285102-001		7
	16	286570-002		1
	17	286547		1
*	18	286556		2
	19	Fan #2 (See Figure 6)		Ref.
	20	286481-003		1
*	21	286488-002		1
		Emergency Stop Components (see also Figure 1)		
*	22	408350		1
*	23	408352		1
*	24	408585		1
*	25	287871-001		1

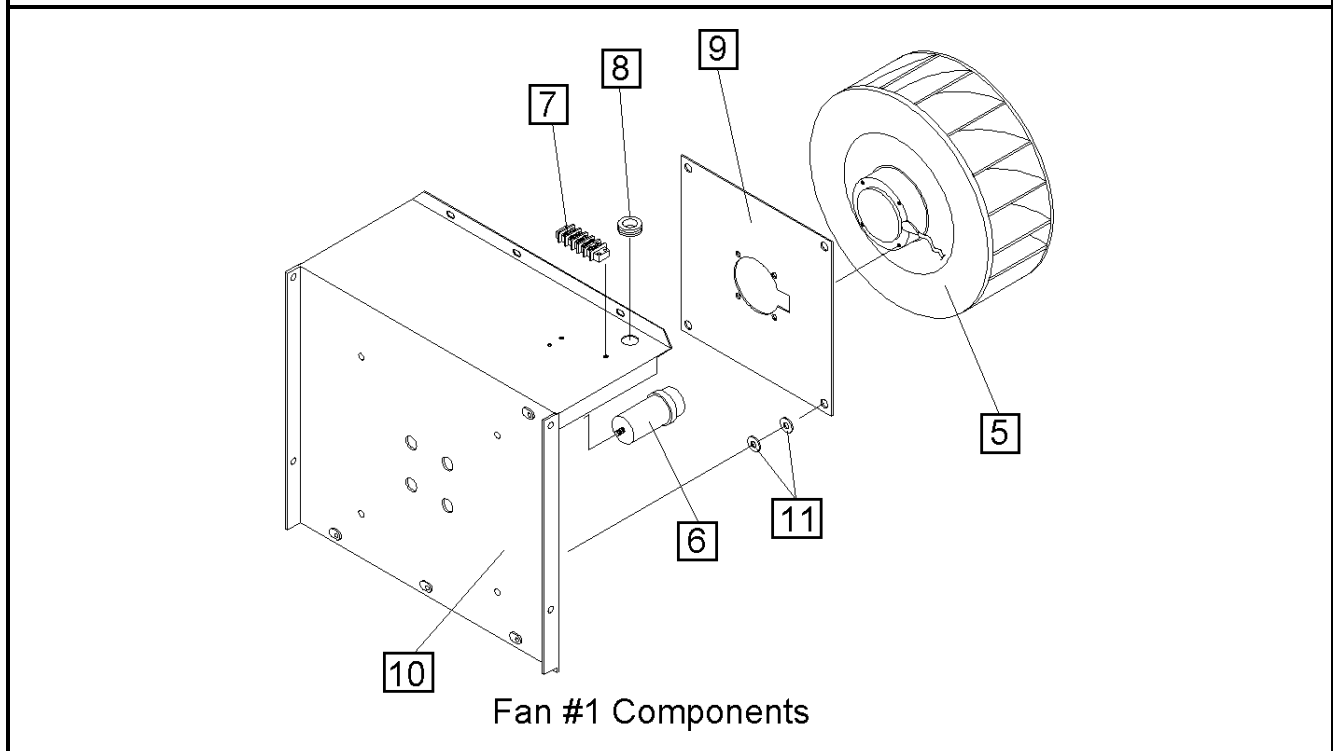
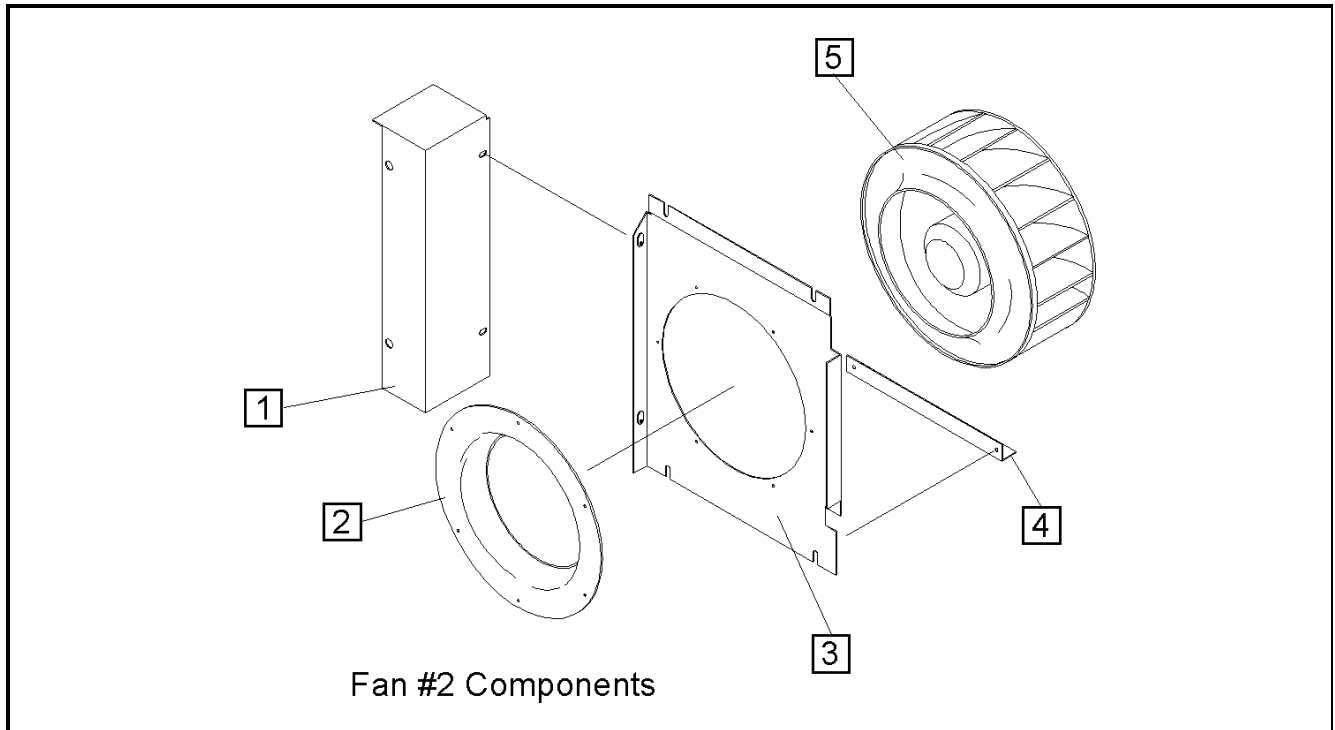

Fan Assembly Components
Figure 6

FIGURE ITEM NO.	HOBART PART NO.	NOMENCLATURE	EFF	UNIT PER ASSY.
6 -	1	287848		1
	2	283157-003		1
	3	287840		1
	4	287839		1
	5	283155-003		2
	6	283156-003		2
	7	401911-005		2
*		400792-001		12
*		286486-001		4
	8	402037-006		1
	9	287846		1
	10	287842		1
	11	281929-015		12

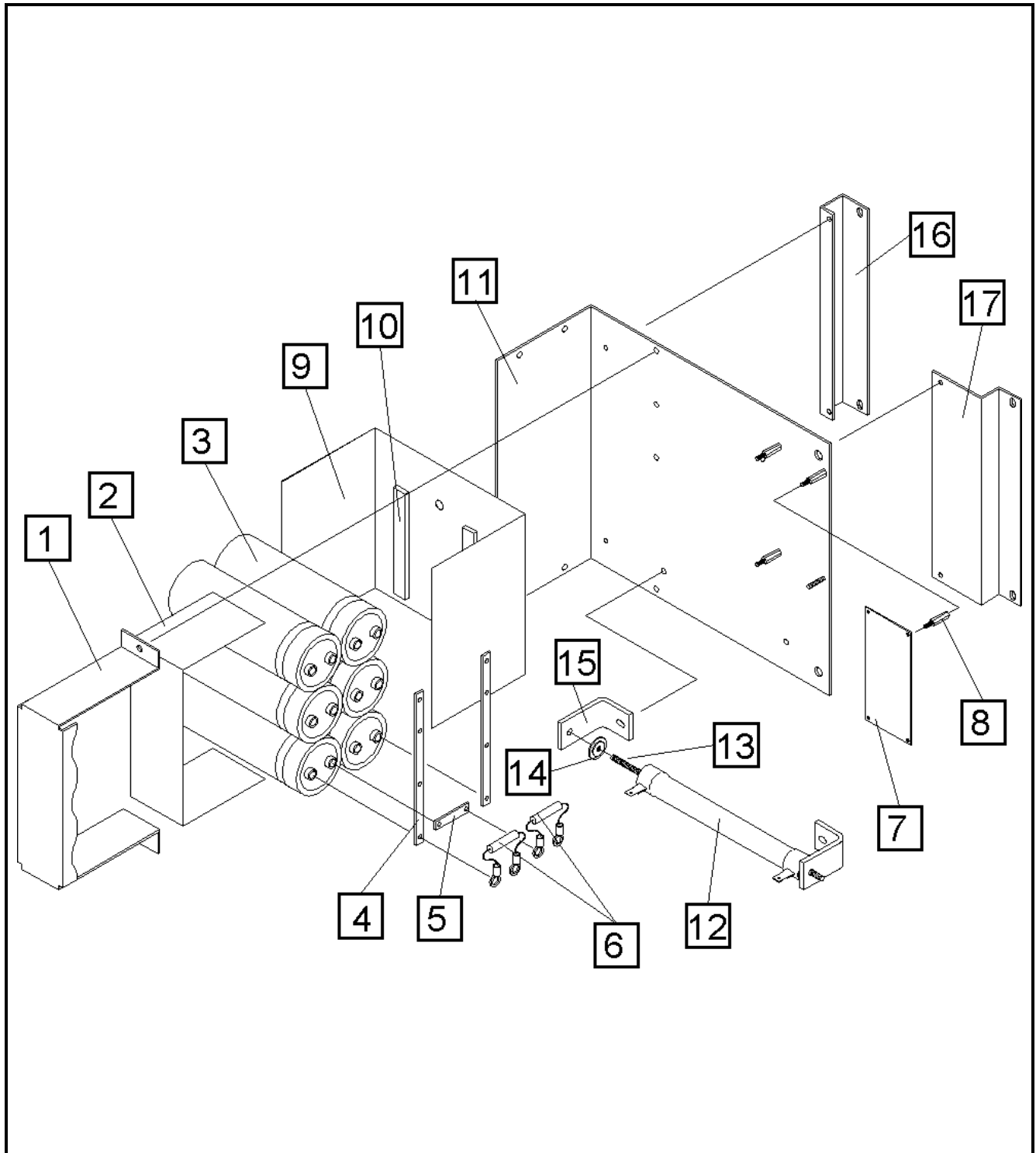

**DC Electrolytic Capacitors Assembly
Figure 7**

FIGURE ITEM NO.	HOBART PART NO.	NOMENCLATURE	EFF	UNIT PER ASSY.
7 -	1	286428		1
	2	286440-001		1
	3	281848-001	DC Capacitors, 6800 MFD	6
	4	286433	Long Bus Bar	2
	5	286431	Short Bus Bar	3
6	281971-001	Resistor Assembly		6
7	286250A	Bus Discharge PC Board Assembly		1
8	284316-002	Metal Standoff		4
9	286434	Bottom and Back Insulator		1
10	056210	Neoprene Rubber Strip		1.5 ft.
11	286536	DC Capacitors Bracket		1
12	404249-003	Resistor, 225 W, 50 ohm (V6Y481)		1
13	283387-002	Threaded Rod		1
14	286489-001	Centering Washer (V44655 #6003)		2
15	286468	Resistor Bracket		2
16	286575	Upper DC Cap Bracket		1
17	286576	Lower DC Cap Bracket		1

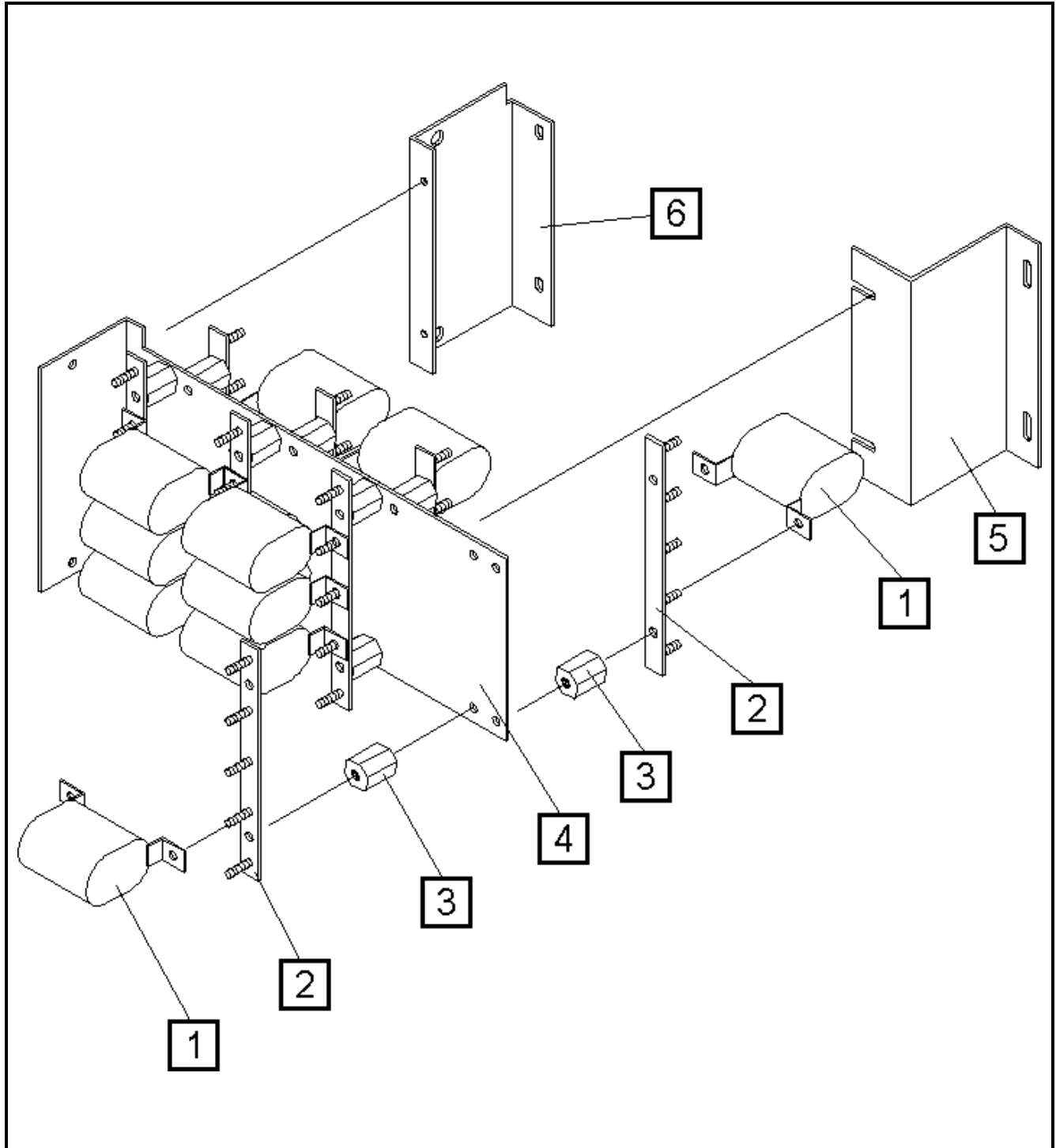

AC Capacitor Assembly
Figure 8

FIGURE ITEM NO.	HOBART PART NO.	NOMENCLATURE	EFF	UNIT PER ASSY.
8 -	1	286389-002		24
	2	286406		8
	3	286266		16
	4	286537		1
	5	286573		1
	6	286574		1
*	7	77A1107		1
*	8	77A1108		1
*	9	77A1109		1
*	10	287867-001		1
*	11	287867-002		1
*	12	287867-003		1
*	13	409077		4

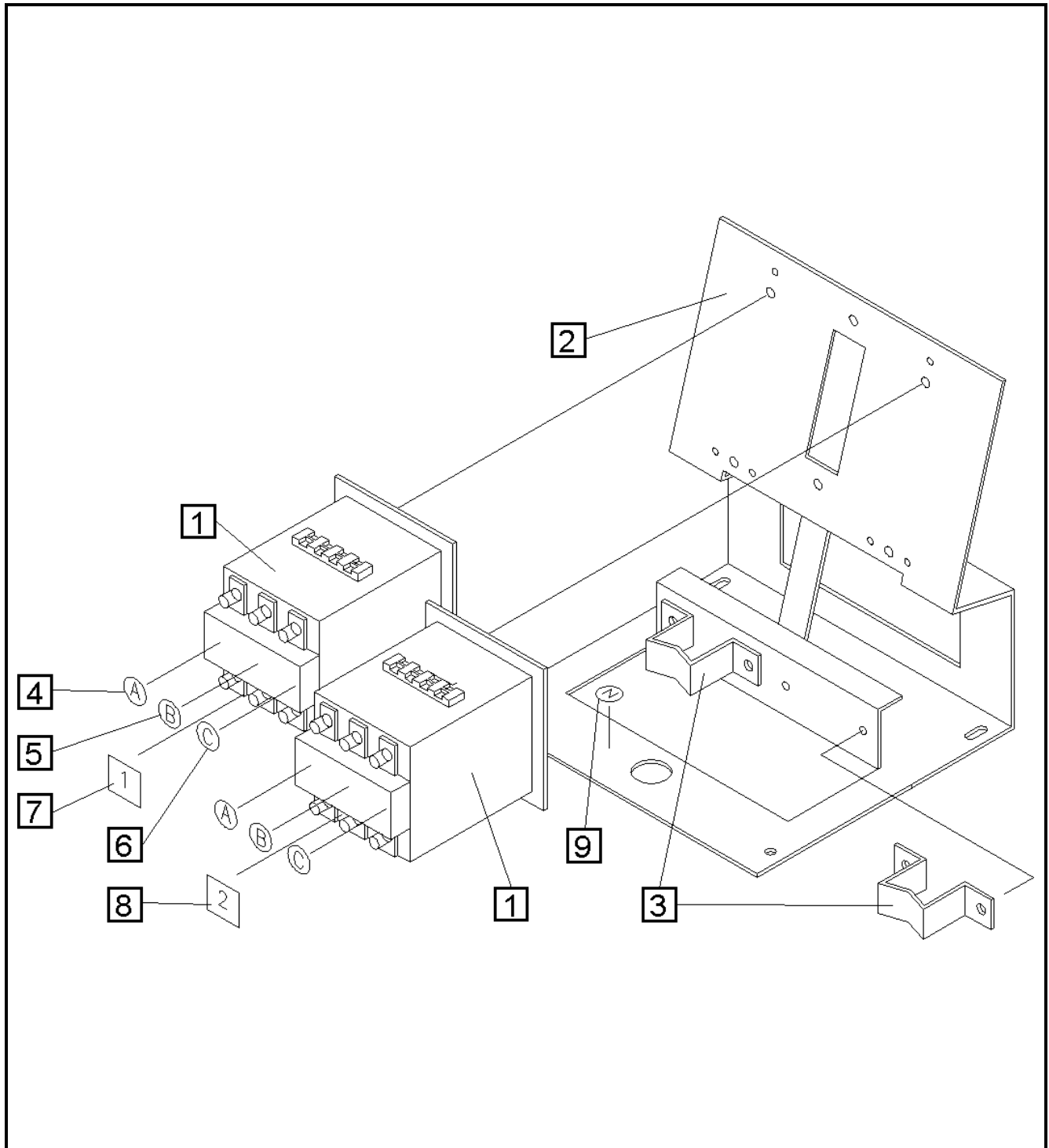

Contactor Panel Assembly
Figure 9

FIGURE ITEM NO.	HOBART PART NO.	NOMENCLATURE	EFF	UNIT PER ASSY.
9 -	1	282130-001		2
	2	286450		1
	3	284359		2
	3	284397		2
	4	77A1107		2
	5	77A1108		2
	6	77A1109		2
	7	402422-001		1
	8	402422-002		1
	9	78A1035		1

Note: Two clamps of different sizes are included for item 3. Use the size appropriate for your AC cable.

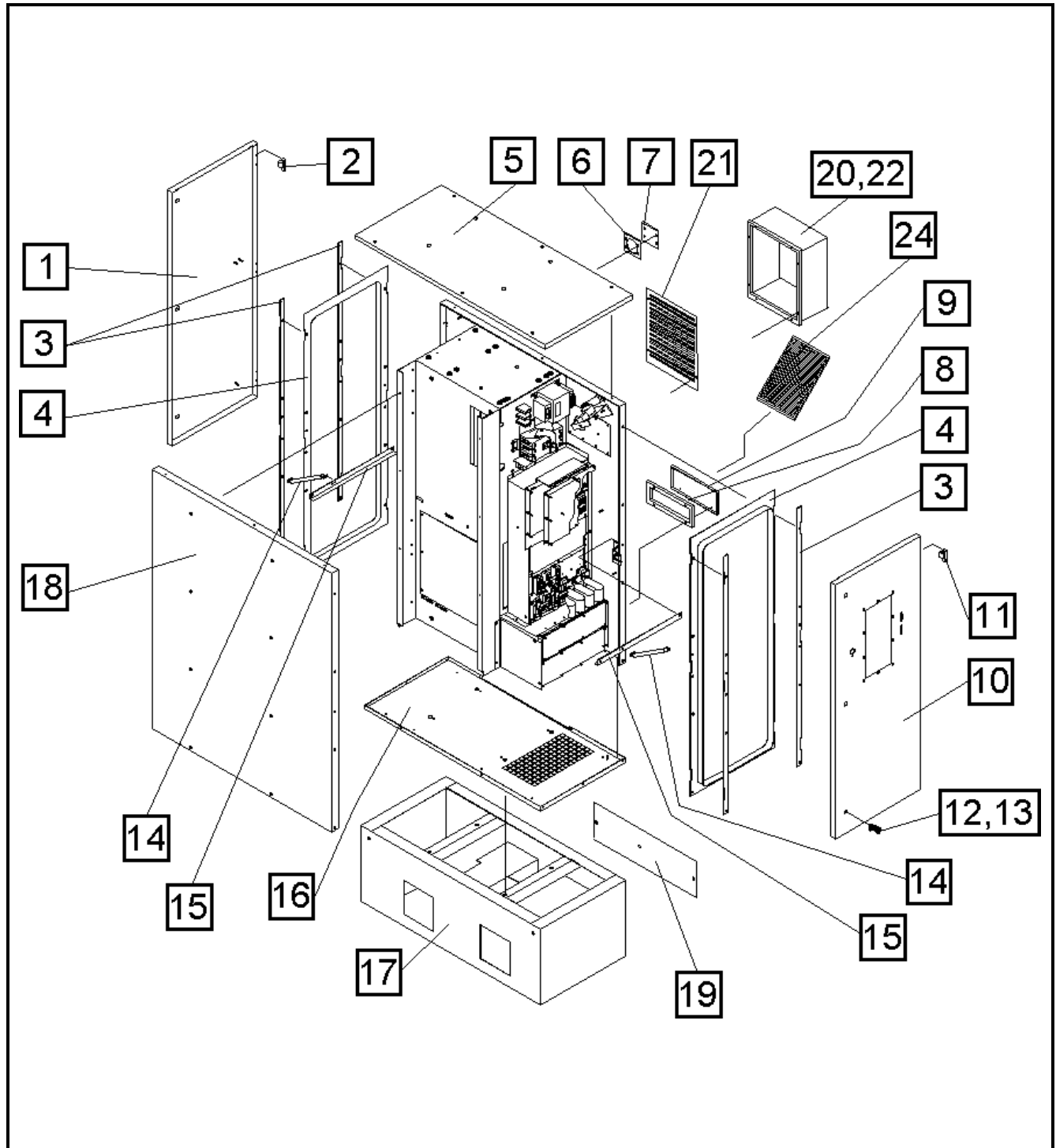

Canopy Components
Figure 10

FIGURE ITEM NO.	HOBART PART NO.	NOMENCLATURE	EFF	UNIT PER ASSY.
10 -	1	286561		1
		286485-001		12 ft.
		286474-016		1
	2	283824		3
	3	286582		4
	4	286564		2
		286485-003		20 ft.
	5	286559		1
	6	286584		2
	7	286479		0
	8	286583		1
	9	286567		1
		283168-003		4
		283172-001		4
	10	286560		1
		286474-015		1
		286485-001		12 ft.
	11	283597		3
	12	287542-001		6
	13	287546-001		6
		288225		6
	14	284606-001		2
	15	286601		2
	16	286565		1
	17	286578		1
	18	288243		1
	19	288239		1
	20	288218		1
	21	288216		1
	22	288220		5.3 ft.
*	23	W10088-008		1
	24	283159-003		1
*	25	286563		1

This page intentionally left blank.

Section 4 Numerical Index

1) Explanation of Numerical Index

The purpose of this index is to assist the user in finding the illustration and description of a part when the part number is known. Part numbers are arranged in alphanumerical sequence. Thus, any part number beginning with the letter "A" would be located at or near the top of the index list. Likewise, a part number "9" would be listed near the end of the list and far below a part number "1000". The figure number and item number location of the part is directly opposite the part. If the part is used in more than one place, each location is listed commencing with the first location the part is listed.

FIGURE ITEM NO.	HOBART PART NO.	FIGURE ITEM NO.	HOBART PART NO.
10-23	W10088-008	5-15	285102-001
3-10	W10502-031	3-2	285104-001
7-10	056210	1-16	285125
5-	16DA4252-037	4-25	285170
3-15	181358	3-3	285315-001
4-	192266-001	3-17	285568
3-19	280673	4-29	286144
5-10	280673	4-6	286246B
3-1	280807	7-7	286250A
2-	280936	8-3	286266
7-3	281848-001	4-28	286274
3-11	281848-002	4-21	286285-001
6-11	281929-015	5-	286316-001
7-6	281971-001	2-2	286354
5-	281971-010	4-10	286367-001
9-1	282130-001	2-3	286376
5-11	283066-002	1-20	286377
6-5	283155-003	5-	286380
6-6	283156-003	5-	286382
2-4	283157-003	4-15	286389-001
6-2	283157-003	8-1	286389-002
10-24	283159-003	5-12	286392-001
10-	283168-003	4-22	286394
2-	283171-002	1-4	286398-002
10-	283172-001	4-7	286400A
4-27	283196-002	8-2	286406
4-23	283196-003	1-3	286411
7-13	283387-002	1-2	286416-001
10-11	283597	3-22	286420
1-8	283714-007	3-18	286423
1-17	283716	7-1	286428
10-2	283824	7-5	286431
4-26	283867-005	7-4	286433
4-5	284316-002	7-9	286434
5-13	284316-002	5-	286438
7-8	284316-002	7-2	286440-001
9-3	284359	1-19	286441
9-3	284397	1-21	286442
10-14	284606-001	4-8	286443

FIGURE ITEM NO.	HOBART PART NO.	FIGURE ITEM NO.	HOBART PART NO.
3-13	286447	10-17	286578
3-14	286448	1-	286580-001
5-	286449	10-3	286582
9-2	286450	10-8	286583
1-9	286457	10-6	286584
7-15	286468	3-	286585
10-	286474-015	10-15	286601
10-	286474-016	3-20	286602
1-26	286475-006	5-9	286602
1-27	286475-007	1-24	287341
10-7	286479	4-30	287353A
5-1	286480-003	1-18	287460
5-20	286481-003	10-12	287542-001
4-11	286482-001	10-13	287546-001
10-	286485-001	4-18	287824
10-	286485-001	4-13	287825
10-	286485-003	4-14	287826
6-	286486-001	4-19	287830
5-21	286488-002	4-20	287831
7-14	286489-001	4-1	287832
5-3	286492-001	4-4	287833
4-9	286528A	3-28	287835
5-	286531-001	6-4	287839
4-16	286533	6-3	287840
2-1	286535	3-23	287841
7-11	286536	6-10	287842
8-4	286537	4-3	287843
1-14	286544	4-2	287844
5-17	286547	6-9	287846
2-7	286555	6-1	287848
5-18	286556	1-	287850
3-26	286557	3-16	287856
10-5	286559	1-25	287858
10-10	286560	8-10	287867-001
10-1	286561	8-11	287867-002
2-5	286563	8-12	287867-003
10-25	286563	5-25	287871-001
10-4	286564	10-21	288216
10-16	286565	10-20	288218
3-24	286566	10-22	288220
10-9	286567	10-	288225
3-25	286568	10-19	288239
3-27	286569	10-18	288243
5-8	286570-001	1-22	288258
5-16	286570-002	1-15	288300
5-	286571	1-23	288730
8-5	286573	5-	288974
8-6	286574	5-5	289751
7-16	286575	3-4	291139
7-17	286576	3-	291268-002
2-6	286577	3-5	291269-003

FIGURE ITEM NO.	HOBART PART NO.
-----------------	-----------------

1-	400613-004
1-	400613-004
1-	400613-004
6-	400792-001
6-7	401911-005
6-8	402037-006
9-7	402422-001
9-8	402422-002
4-	402674-001
4-	402674-002
3-12	402682
1-10	402987
4-17	403955-021
4-12	404044-004
7-12	404249-003
3-9	404960-034
4-24	407970
5-22	408350
5-23	408352
5-24	408585
8-13	409077
5-4	493712
4-33	77A1107
8-7	77A1107
9-4	77A1107
4-32	77A1108
8-8	77A1108
9-5	77A1108
4-31	77A1109
8-9	77A1109
9-6	77A1109
1-	77A1157
9-9	78A1035
1-6	82B1066-001
1-7	82B1066-010
1-5	82B1066-012
3-8	83A1112
3-7	83A1113
3-6	83A1114

This page intentionally left blank.

Chapter 5 Manufacturer's Literature

Manufacturer's Literature

Diagram Number	Diagram Description
287860, Rev. 8	Diagram, Schematic & Connection
286495, Rev. 9	Outline, Dimensional

Contact Hobart Ground Power if either copy of these drawings is not with this manual (unless otherwise noted above). Refer to Appendix A for specific information on the 400 Hz Solid State Converter optional equipment.

This page intentionally left blank.

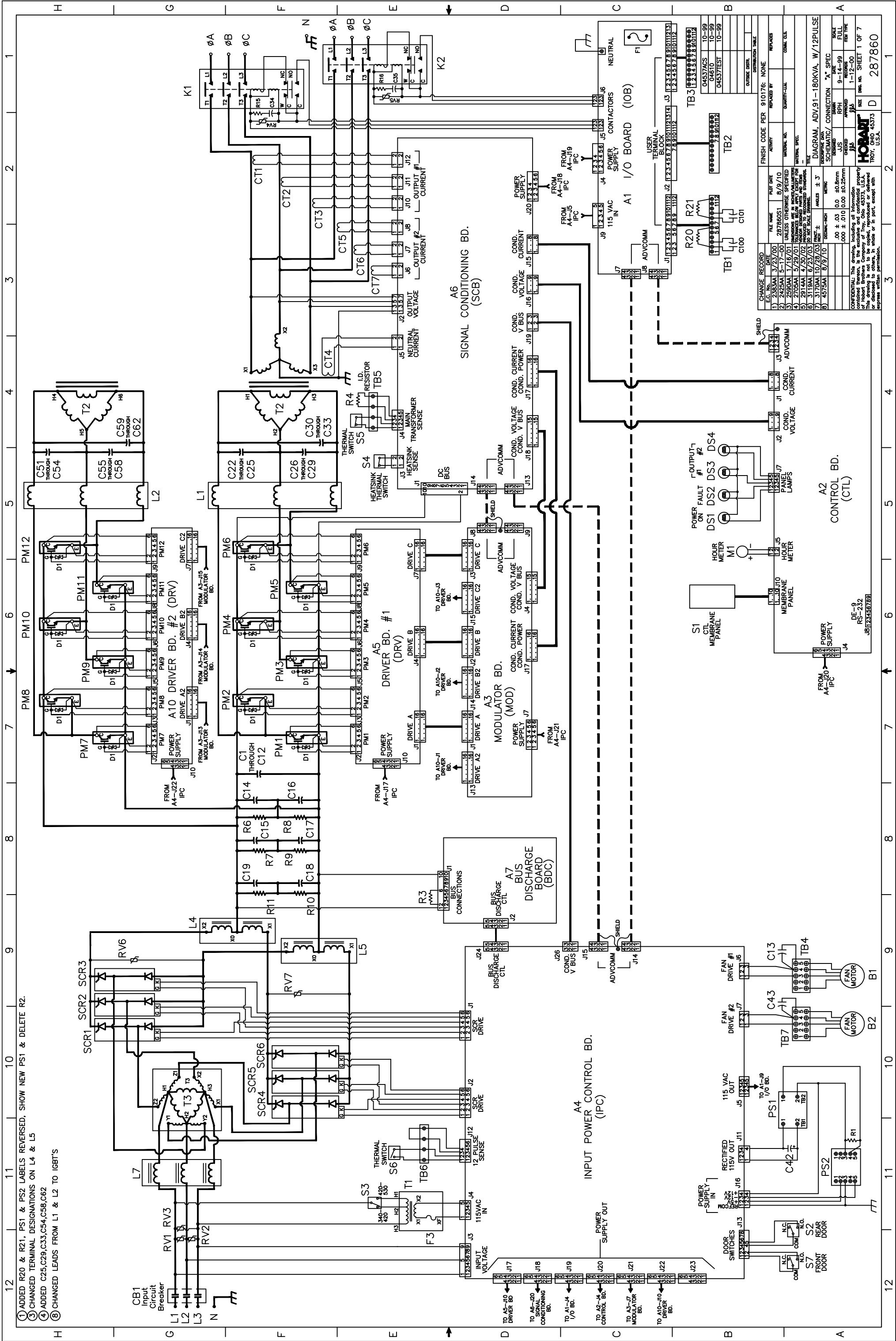

- ① ADDED R20 & R21, PS1 & PS2 LABELS REVERSED, SHOW NEW PS1 & DELETE R2.
- ② CHANGED TERMINAL DESIGNATIONS ON L4 & L5
- ③ CHANGED C25, C29, C33, C54, C58, C62
- ④ ADDED C25, C29, C33, C54, C58, C62
- ⑤ CHANGED LEADS FROM L1 & L2 TO IGBT'S

CHANGE RECORD		FILE NAME	DATE	ACTIVITY	FINISH CODE PER 910176: NONE	REPLACED BY	REPLACES
1	2/25/00	287860S1	8/9/10	UNLESS OTHERWISE SPECIFIED			
2	5/16/00			QUANTITY-LIST			
3	5/16/00			UNLESS OTHERWISE SPECIFIED			
4	5/16/00			QUANTITY-LIST			
5	5/16/00			UNLESS OTHERWISE SPECIFIED			
6	5/16/00			QUANTITY-LIST			
7	5/16/00			UNLESS OTHERWISE SPECIFIED			
8	5/16/00			QUANTITY-LIST			
9	5/16/00			UNLESS OTHERWISE SPECIFIED			
10	5/16/00			QUANTITY-LIST			
11	5/16/00			UNLESS OTHERWISE SPECIFIED			
12	5/16/00			QUANTITY-LIST			

DIAGRAM, ADV.91-180KVA, W/12PULSE		DATE	ACTIVITY	FINISH CODE PER 910176: NONE	REPLACED BY	REPLACES
1	2/25/00	287860S1	8/9/10	UNLESS OTHERWISE SPECIFIED		
2	5/16/00			QUANTITY-LIST		
3	5/16/00			UNLESS OTHERWISE SPECIFIED		
4	5/16/00			QUANTITY-LIST		
5	5/16/00			UNLESS OTHERWISE SPECIFIED		
6	5/16/00			QUANTITY-LIST		
7	5/16/00			UNLESS OTHERWISE SPECIFIED		
8	5/16/00			QUANTITY-LIST		
9	5/16/00			UNLESS OTHERWISE SPECIFIED		
10	5/16/00			QUANTITY-LIST		
11	5/16/00			UNLESS OTHERWISE SPECIFIED		
12	5/16/00			QUANTITY-LIST		

DIAGRAM, ADV.91-180KVA, W/12PULSE		DATE	ACTIVITY	FINISH CODE PER 910176: NONE	REPLACED BY	REPLACES
1	2/25/00	287860S1	8/9/10	UNLESS OTHERWISE SPECIFIED		
2	5/16/00			QUANTITY-LIST		
3	5/16/00			UNLESS OTHERWISE SPECIFIED		
4	5/16/00			QUANTITY-LIST		
5	5/16/00			UNLESS OTHERWISE SPECIFIED		
6	5/16/00			QUANTITY-LIST		
7	5/16/00			UNLESS OTHERWISE SPECIFIED		
8	5/16/00			QUANTITY-LIST		
9	5/16/00			UNLESS OTHERWISE SPECIFIED		
10	5/16/00			QUANTITY-LIST		
11	5/16/00			UNLESS OTHERWISE SPECIFIED		
12	5/16/00			QUANTITY-LIST		

CONFIDENTIAL This drawing, including all information contained herein, is the exclusive and confidential property of HOBBIT. It is not to be copied, reproduced or delivered in any form or by any means, electronic or mechanical, including photocopying, recording, or by any information storage and retrieval system, without the prior written permission of HOBBIT.

DE-9
RS-232
J8(123456789)

DE-9
RS-232
J8(123456789)

287860

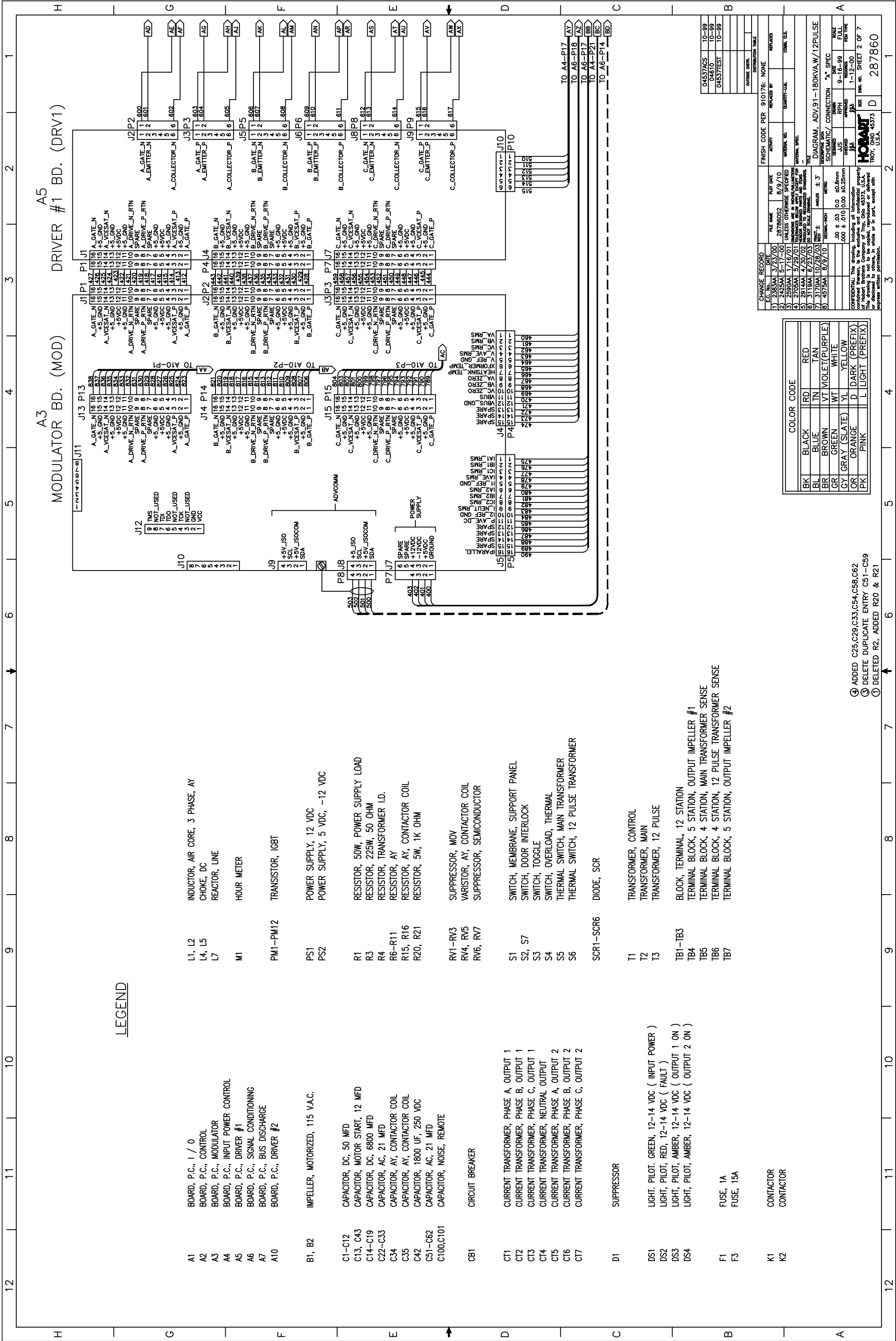

④ ADDED C25,C29,C33,C54,C58,C62
 ③ DELETE DUPLICATE ENTRY C51-C59
 ① DELETED R2, ADDED R20 & R21

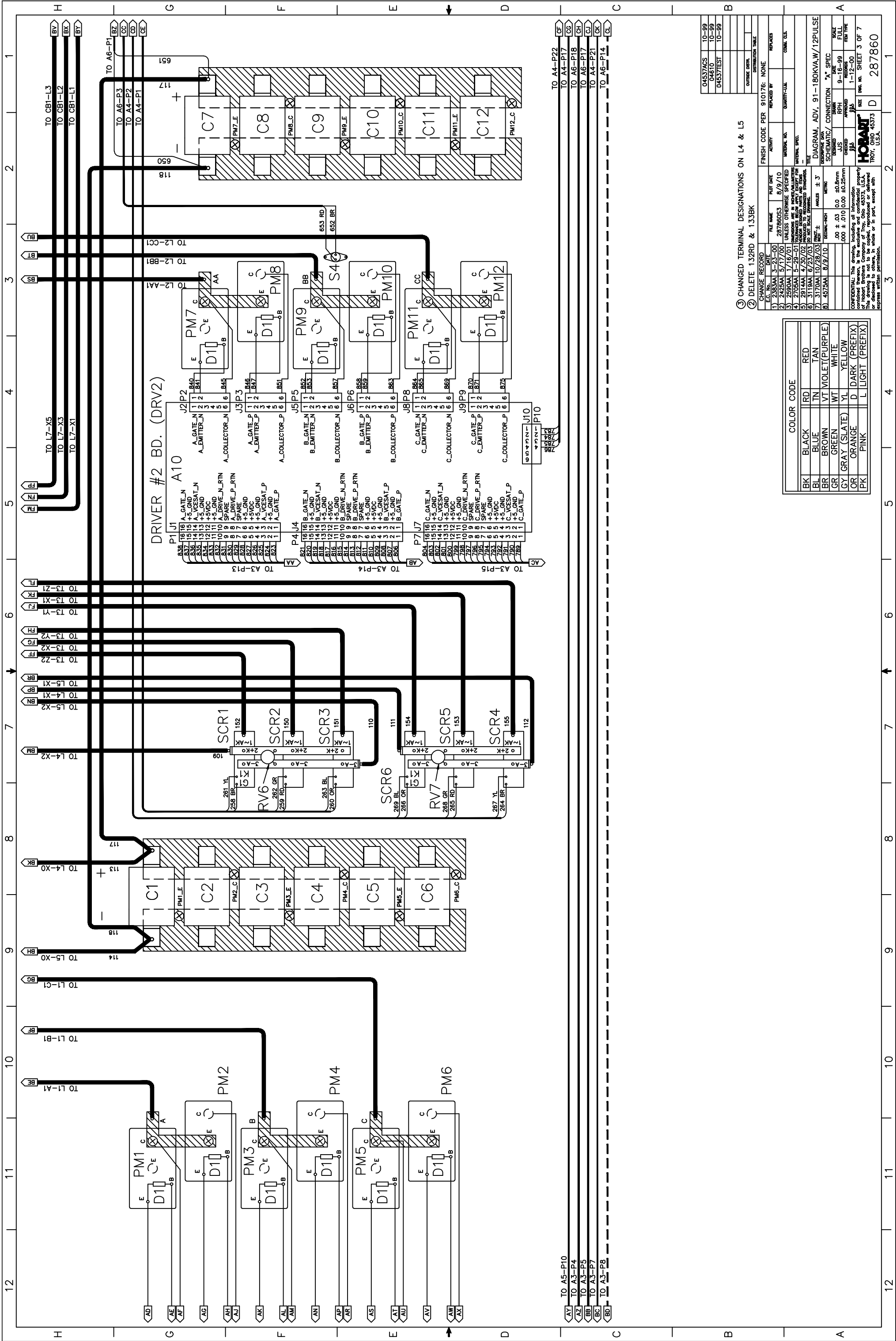

COLOR CODE	
BK	BLACK
BL	BLUE
BR	BROWN
GR	GREEN
GY	GRAY (SLATE)
OR	ORANGE
PK	PINK
RD	RED
TAN	TAN
VT	VOLET (PURPLE)
WT	WHITE
YL	YELLOW
D	DARK (PREFIX)
L	LIGHT (PREFIX)

③ CHANGED TERMINAL DESIGNATIONS ON L4 & L5
 ② DELETE 132RD & 133BK

CHANGE RECORD		FINISH CODE PER 910176: NONE	
E.C. NO.	DATE	ACTIVITY	REPLACED BY
1	2/25/84	3-25-00	287860S3
2	5/23/84	3/16/00	UNLESS OTHERWISE SPECIFIED DIMENSIONS ARE IN INCHES/MILLIMETERS
3	2/20/84	5-29-01	UNLESS OTHERWISE SPECIFIED DIMENSIONS ARE IN INCHES/MILLIMETERS
4	2/20/84	5-29-01	UNLESS OTHERWISE SPECIFIED DIMENSIONS ARE IN INCHES/MILLIMETERS
5	2/21/84	4/30/02	UNLESS OTHERWISE SPECIFIED DIMENSIONS ARE IN INCHES/MILLIMETERS
6	3/19/84	6/23/03	UNLESS OTHERWISE SPECIFIED DIMENSIONS ARE IN INCHES/MILLIMETERS
7	3/17/84	10/28/03	UNLESS OTHERWISE SPECIFIED DIMENSIONS ARE IN INCHES/MILLIMETERS
8	4/25/84	8/9/10	UNLESS OTHERWISE SPECIFIED DIMENSIONS ARE IN INCHES/MILLIMETERS

DIAGRAM, ADV. 91-180KVA.W/12PULSE
 SCHEMATIC/ CONNECTION "A" SPEC
 REVISIONS: 9-18-99 FULL, 1-12-00 REBTYPE

CONFIDENTIAL: This drawing, including all information contained herein, is the exclusive and confidential property of HOBIANT. It is not to be copied, reproduced or delivered in any form or by any means without the prior written permission of HOBIANT.

HOBIANT
 TROY, OHIO 45373 U.S.A.

SIZE: 1-12-00
 SHEET: 3 OF 7
 287860

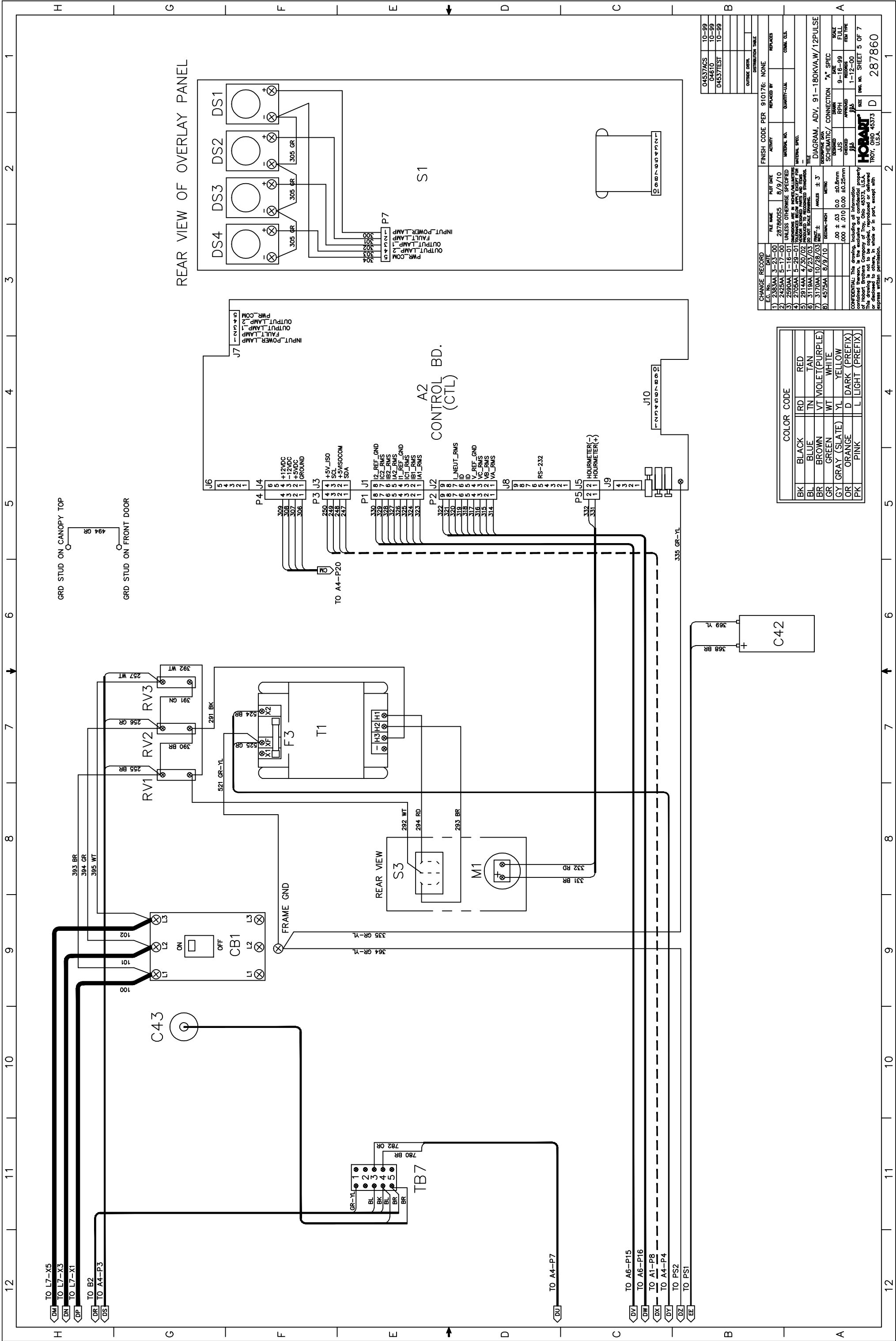

REAR VIEW OF OVERLAY PANEL

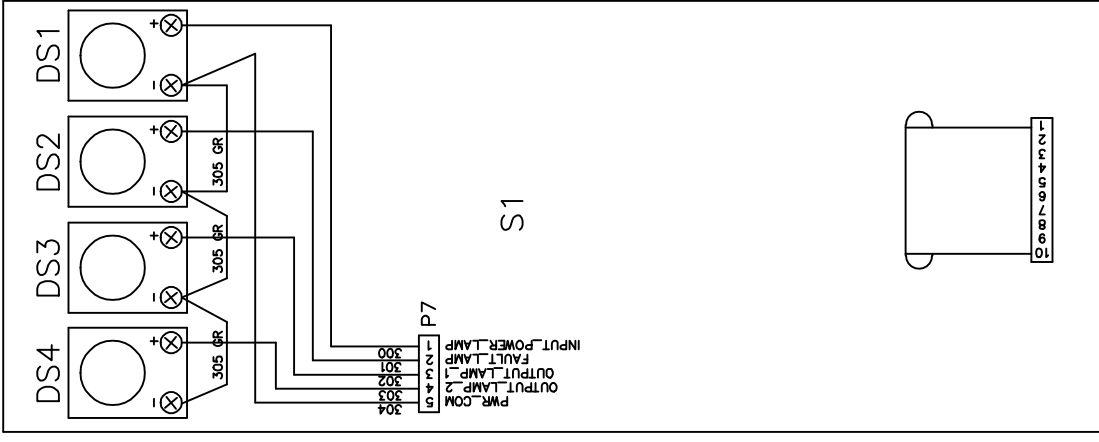

COLOR CODE	
BK	BLACK
BL	BLUE
BR	BROWN
GR	GREEN
GY	GRAY (SLATE)
OR	ORANGE
PK	PINK
RD	RED
TN	TAN
VT	VOLET(PURPLE)
WT	WHITE
YL	YELLOW
D	DARK (PREFIX)
L	LIGHT (PREFIX)

CHANGE RECORD		FINISH CODE PER 910176: NONE	
E.C. NO.	DATE	ACTIVITY	REPLACED BY
1	2/25/84	3-23-00	287860SS
2	5/23/84	3-16-00	UNLESS OTHERWISE SPECIFIED
3	5/23/84	5-29-01	DIMENSIONS ARE IN INCHES/MILLIMETERS
4	5/23/84	4-30-02	UNLESS OTHERWISE SPECIFIED
5	20/1/84	6/23/03	UNLESS OTHERWISE SPECIFIED
6	31/1/84	10/28/03	UNLESS OTHERWISE SPECIFIED
7	31/7/84	10/28/03	UNLESS OTHERWISE SPECIFIED
8	45/2/84	8/9/10	UNLESS OTHERWISE SPECIFIED

DIAGRAM, ADV. 91-180KVA/W/12PULSE	
REVISION	DATE
1	9-18-99
2	1-12-00

HOBART	
SIZE	REV. NO.
D	5 OF 7

DISTRIBUTION TABLE	
OUTSIDE CONTR.	REPLACES
04537ACS	10-99
04610	10-99
04537TEST	10-99

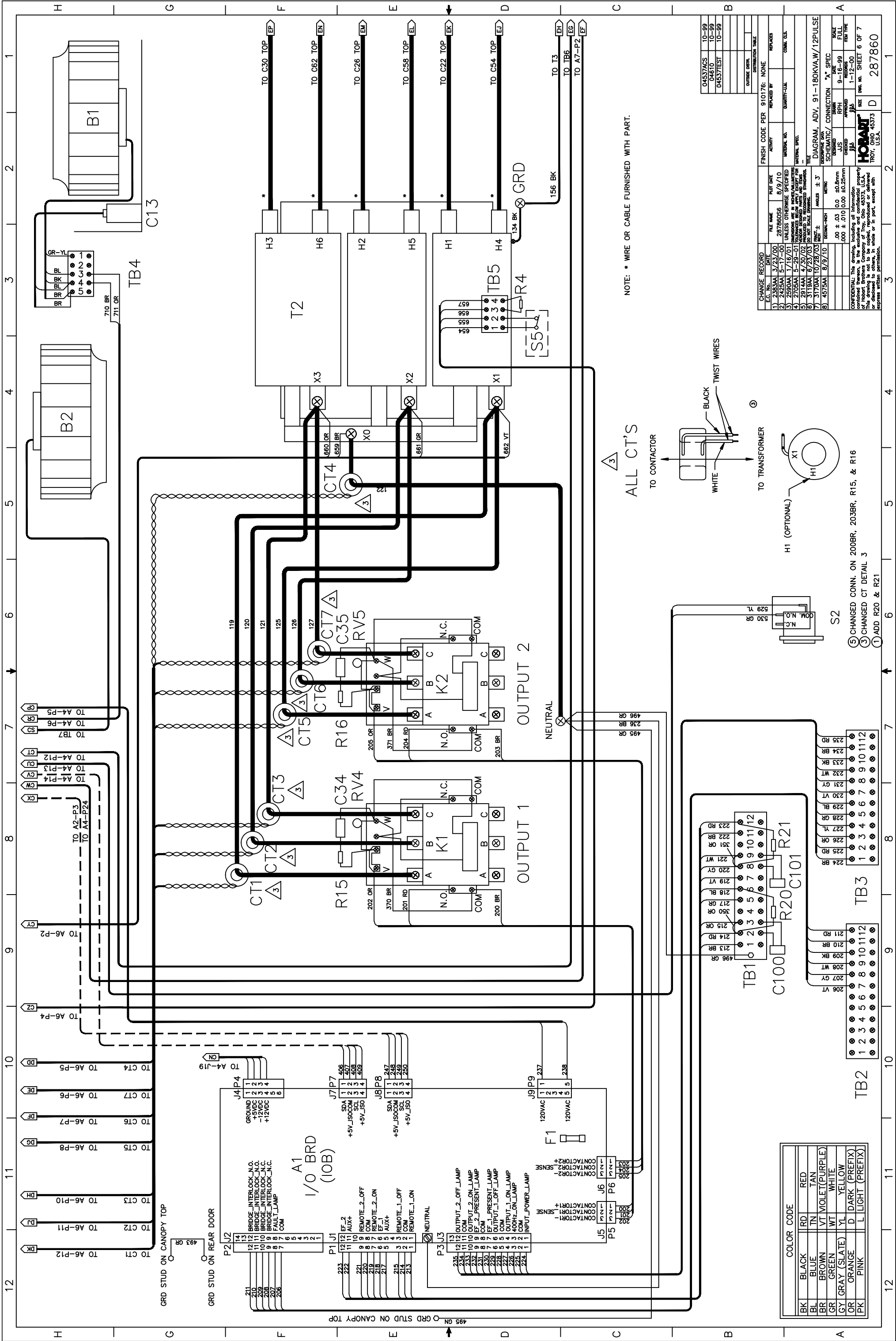

NOTE: * WIRE OR CABLE FURNISHED WITH PART.

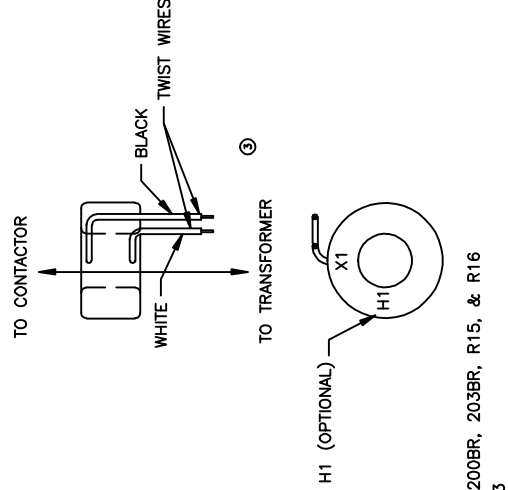

⑤ CHANGED CONN. ON 200BR, 203BR, R15, & R16
③ CHANGED CT DETAIL 3
① ADD R20 & R21

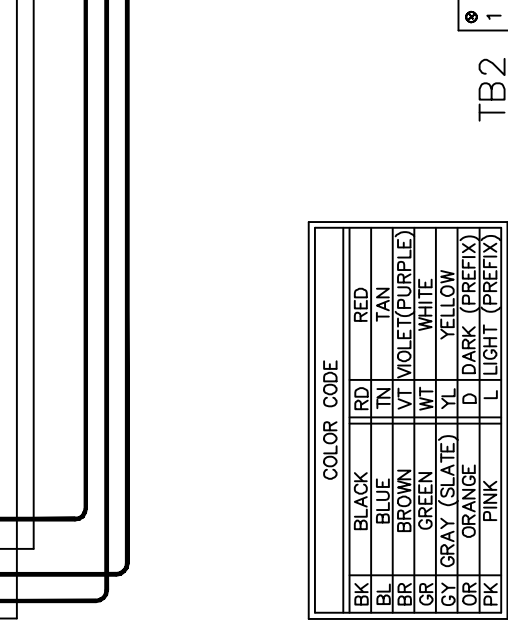
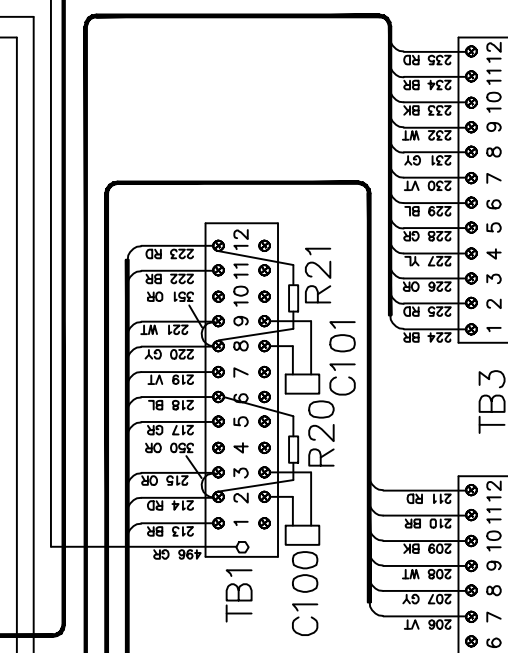

⑤ CHANGED CONN. ON 200BR, 203BR, R15, & R16
③ CHANGED CT DETAIL 3
① ADD R20 & R21

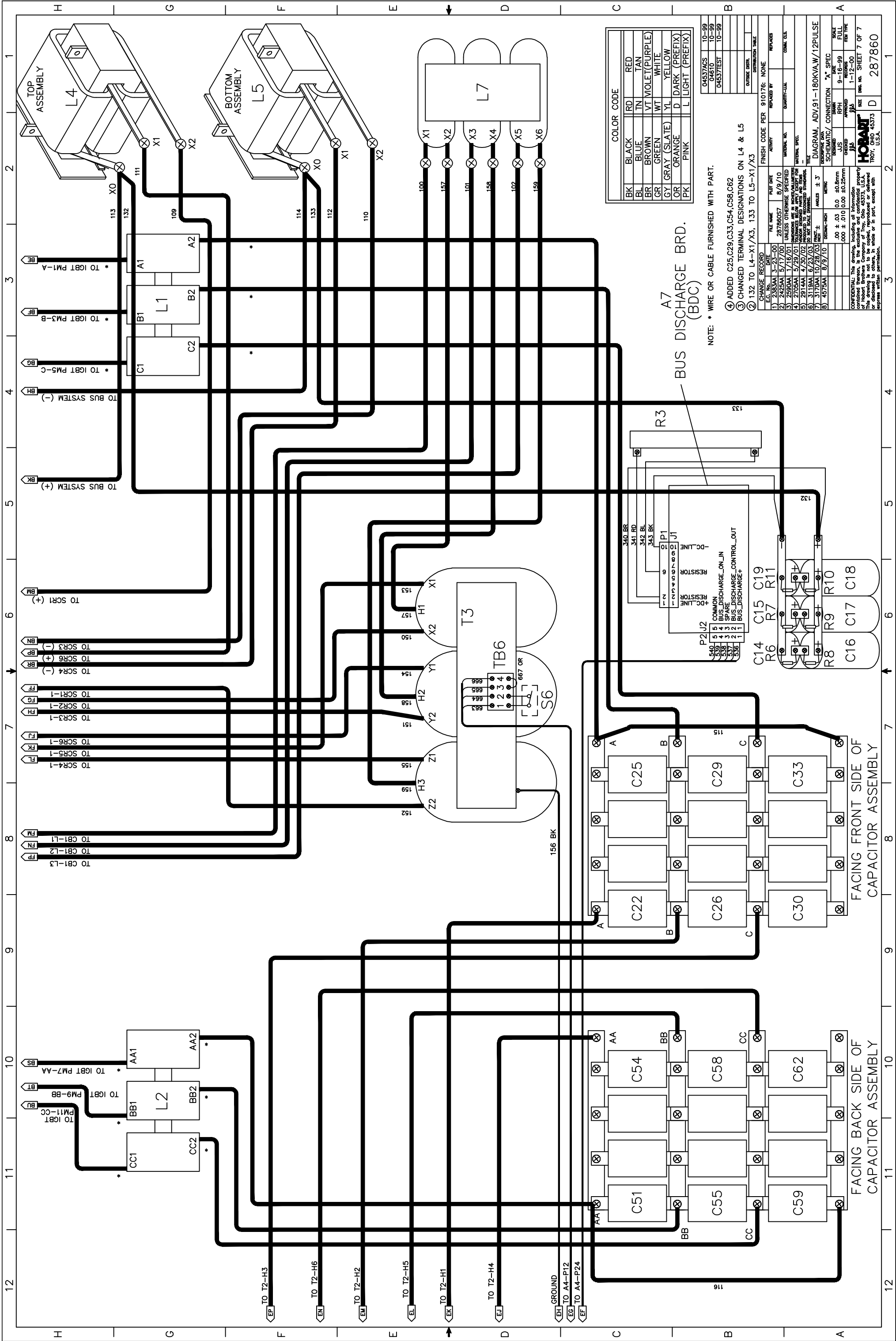

COLOR CODE

BK	BLACK	RD	RED
BL	BLUE	TN	TAN
BR	BROWN	VT	VIOLET(PURPLE)
GR	GREEN	WT	WHITE
GY	GRAY (SLATE)	YL	YELLOW
OR	ORANGE	D	DARK (PREFIX)
PK	PINK	L	LIGHT (PREFIX)

CHANGE RECORD

EC. NO.	DATE	DESCRIPTION
1	2/25/01	3-25-00
2	2/25/01	3-25-00
3	2/25/01	3-25-00
4	2/25/01	3-25-00
5	2/25/01	3-25-00
6	2/25/01	3-25-00
7	2/25/01	3-25-00
8	2/25/01	3-25-00

FINISH CODE PER 910176: NONE

REVISIONS

NO.	DATE	DESCRIPTION
1	8/9/10	287860S7
2	8/9/10	287860S7
3	8/9/10	287860S7
4	8/9/10	287860S7
5	8/9/10	287860S7
6	8/9/10	287860S7
7	8/9/10	287860S7
8	8/9/10	287860S7

DIAGRAM, ADV.91-180KVA.W/12PULSE

SCHEMATIC/ CONNECTION "A" SPEC

NO.	DATE	DESCRIPTION
1	8/9/10	287860S7
2	8/9/10	287860S7
3	8/9/10	287860S7
4	8/9/10	287860S7
5	8/9/10	287860S7
6	8/9/10	287860S7
7	8/9/10	287860S7
8	8/9/10	287860S7

CONFIDENTIAL This drawing, including all information contained herein, is the exclusive and confidential property of HOBASIT. It is not to be copied, reproduced or delivered or disclosed to others, in whole or in part, except with express written permission.

HOBASIT
TROY, OHIO 45373 U.S.A.

REV. NO. 287860
SHEET 7 OF 7

A7
BUS DISCHARGE BRD.
(BDC)

NOTE: * WIRE OR CABLE FURNISHED WITH PART.

- ④ ADDED C25,C29,C33,C54,C58,C62
- ③ CHANGED TERMINAL DESIGNATIONS ON L4 & L5
- ② 132 TO L4-X1/X3, 133 TO L5-X1/X3

FACING FRONT SIDE OF
CAPACITOR ASSEMBLY

FACING BACK SIDE OF
CAPACITOR ASSEMBLY

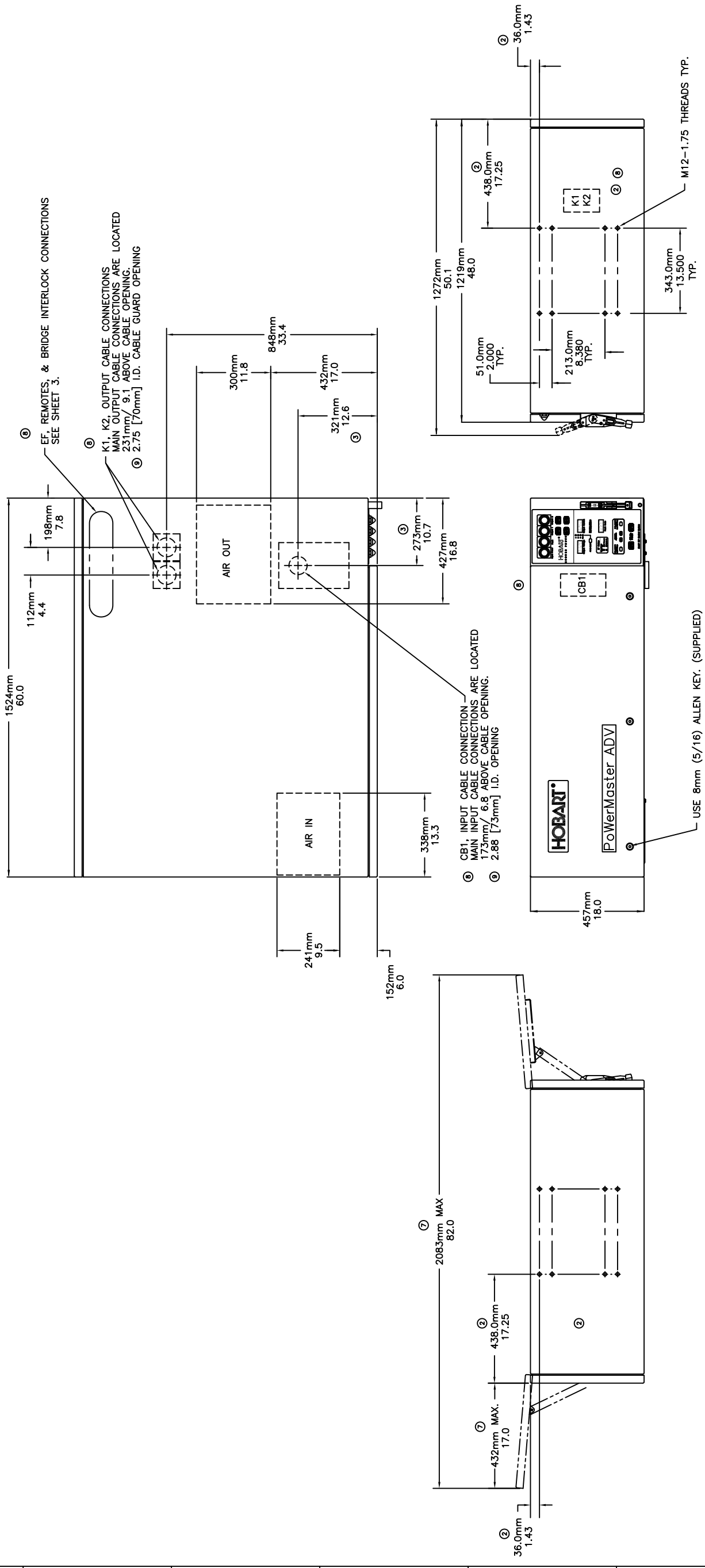

DIMENSIONS IN MILLIMETERS AND INCHES.

WEIGHTS

MODEL	STANDARD	WITH PULSE OPTION	WITH 208,240, OR 600 VOLT INPUT OPTION	WITH 28 V DC OPTION
① 60/90SX200	1020 lbs. 463 kg.	1270 lbs. 576 kg.	1228 lbs. 557 kg.	1203 lbs. 546 kg.
① 45SX200	1020 lbs. 463 kg.	—	1228 lbs. 557 kg.	1203 lbs. 546 kg.
② 120/160SX200	1330 lbs. 603 kg.	1782 lbs. 808 kg.	1710 lbs. 776 kg.	—

⑥ * ADD 80 lbs./36 kg FOR BRIDGE BRACKETS

CHANGE RECORD	FILE NAME	DATE	DESCRIPTION
1	2125AA	3-17-99	INITIAL
2	2243AA	8-12-99	286495
3	2284AA	11-17-99	UNLESS OTHERWISE SPECIFIED
4	2460AA	8/3/00	UNLESS OTHERWISE SPECIFIED
5	2594AA	1/22/01	UNLESS OTHERWISE SPECIFIED
6	2670AA	3-20-01	UNLESS OTHERWISE SPECIFIED
7	2683AA	4/5/01	UNLESS OTHERWISE SPECIFIED
8	2848AA	1/2/02	UNLESS OTHERWISE SPECIFIED
9	3096AA	5/2/03	UNLESS OTHERWISE SPECIFIED

FINISH CODE PER 910176:	REPLACED BY	REPLACES
NONE	—	—

OUTLINE, DIMENSIONAL	DATE	SCALE
ADV CONVERTER	11/7/97	EIGHTH
APPROVED	2-27-98	REVISIONS
—	—	—

SIZE	NO. SHEET	OF	TOTAL SHEETS
D	1	3	3

DATE	BY	NO.
286495	—	—

HOBART
TROY, OHIO 45373 U.S.A.

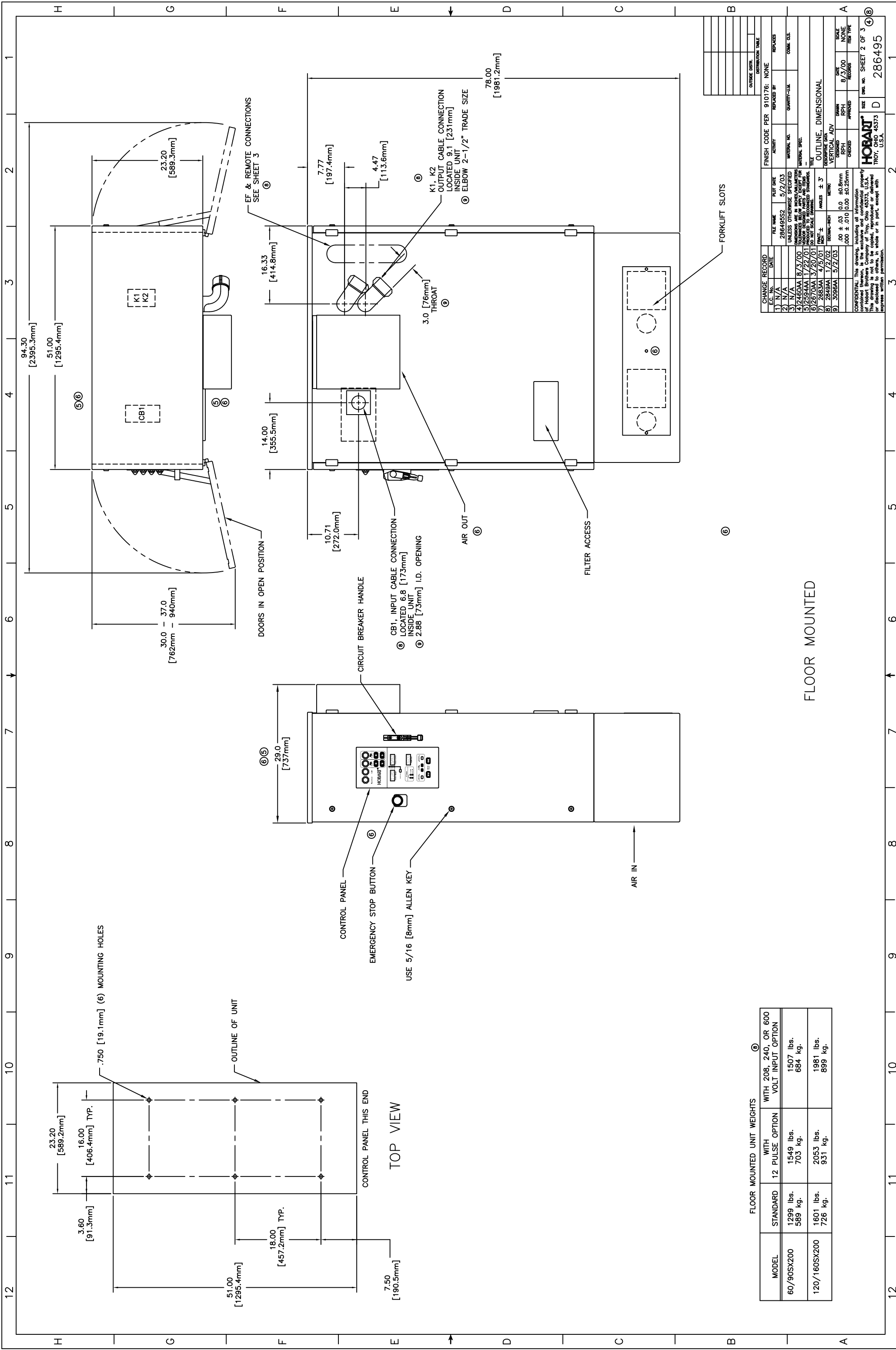

FLOOR MOUNTED UNIT WEIGHTS (6)

MODEL	STANDARD	WITH 12 PULSE OPTION	WITH 208, 240, OR 600 VOLT INPUT OPTION
60/90SX200	1299 lbs. 589 kg.	1549 lbs. 703 kg.	1507 lbs. 684 kg.
120/160SX200	1601 lbs. 726 kg.	2053 lbs. 931 kg.	1981 lbs. 899 kg.

CHANGE RECORD	FILE NAME	PLAT DATE	FINISH CODE PER 910176:	NONE
1) N/A	286495S2	5/2/03	ACTIVITY	REPLACED BY
2) N/A	UNLESS OTHERWISE SPECIFIED		MATERIAL NO.	QUANTITY-LIN
3) N/A	DIMENSIONS ARE IN INCHES/MILLIMETERS		UNLESS OTHERWISE SPECIFIED	COMM. ELE.
4) 2460AA 8/3/00	REVISIONS ARE IN INCHES/MILLIMETERS		UNLESS OTHERWISE SPECIFIED	
5) 2594AA 1/22/01	REVISIONS ARE IN INCHES/MILLIMETERS		UNLESS OTHERWISE SPECIFIED	
6) 2670AA 3/20/01	REVISIONS ARE IN INCHES/MILLIMETERS		UNLESS OTHERWISE SPECIFIED	
7) 2683AA 4/5/01	REVISIONS ARE IN INCHES/MILLIMETERS		UNLESS OTHERWISE SPECIFIED	
8) 2848AA 1/2/02	REVISIONS ARE IN INCHES/MILLIMETERS		UNLESS OTHERWISE SPECIFIED	
9) 3098AA 5/2/03	REVISIONS ARE IN INCHES/MILLIMETERS		UNLESS OTHERWISE SPECIFIED	

OUTLINE, DIMENSIONAL

VERTICAL ADV

REVISIONS

FLOOR MOUNTED

AIRCRAFT CABLE CONNECTIONS:
9/16 SOCKET WITH EXTENSION REQUIRED
CABLE CLAMPS: 10mm SOCKET WITH
EXTENSION REQUIRED

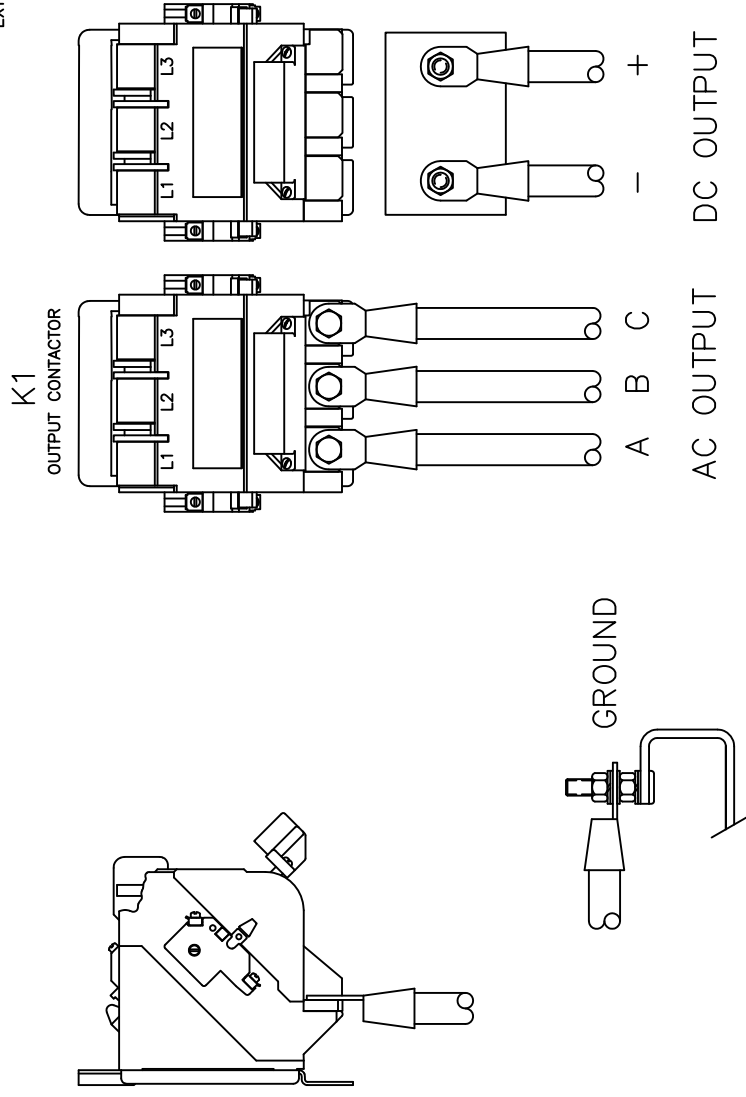

AIRCRAFT CABLE CONNECTIONS FOR AC/DC OUTPUT UNITS

AIRCRAFT CABLE CONNECTIONS:
9/16 SOCKET WITH EXTENSION REQUIRED
CABLE CLAMPS: 10mm SOCKET WITH
EXTENSION REQUIRED

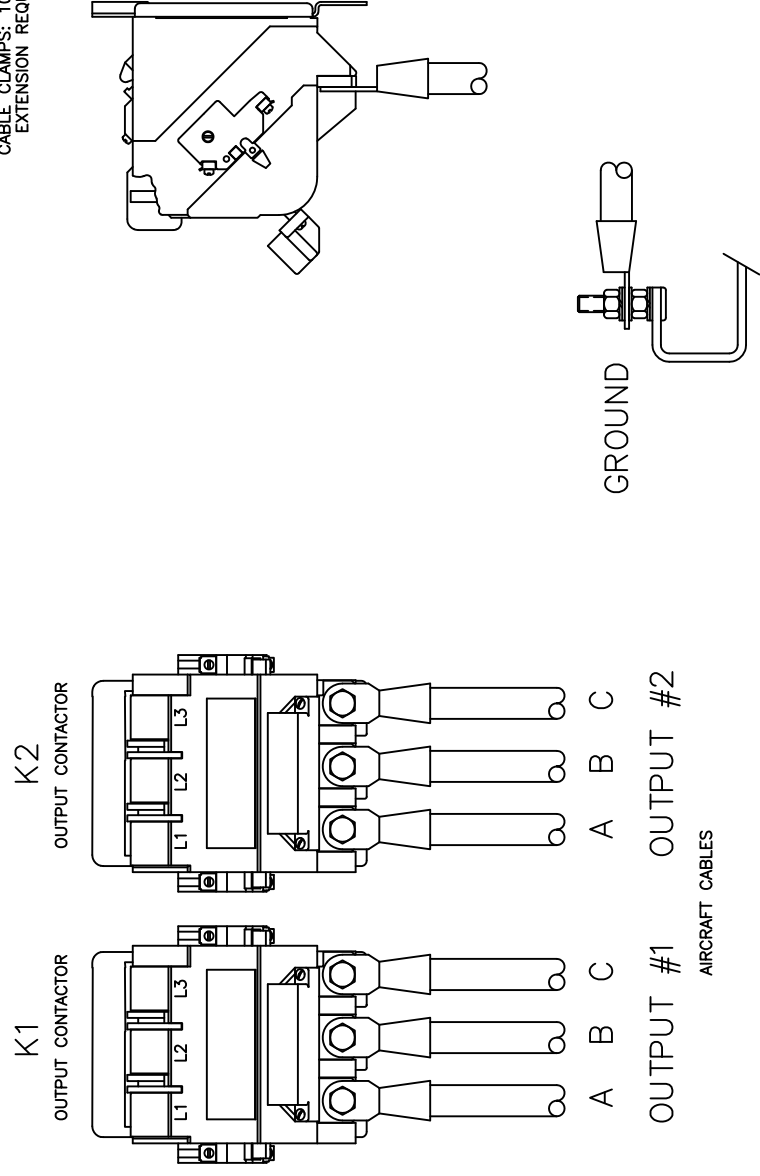

AIRCRAFT CABLE CONNECTIONS FOR 1 OR 2 OUTPUT UNITS

FLAT BLADED SCREW DRIVER REQUIRED

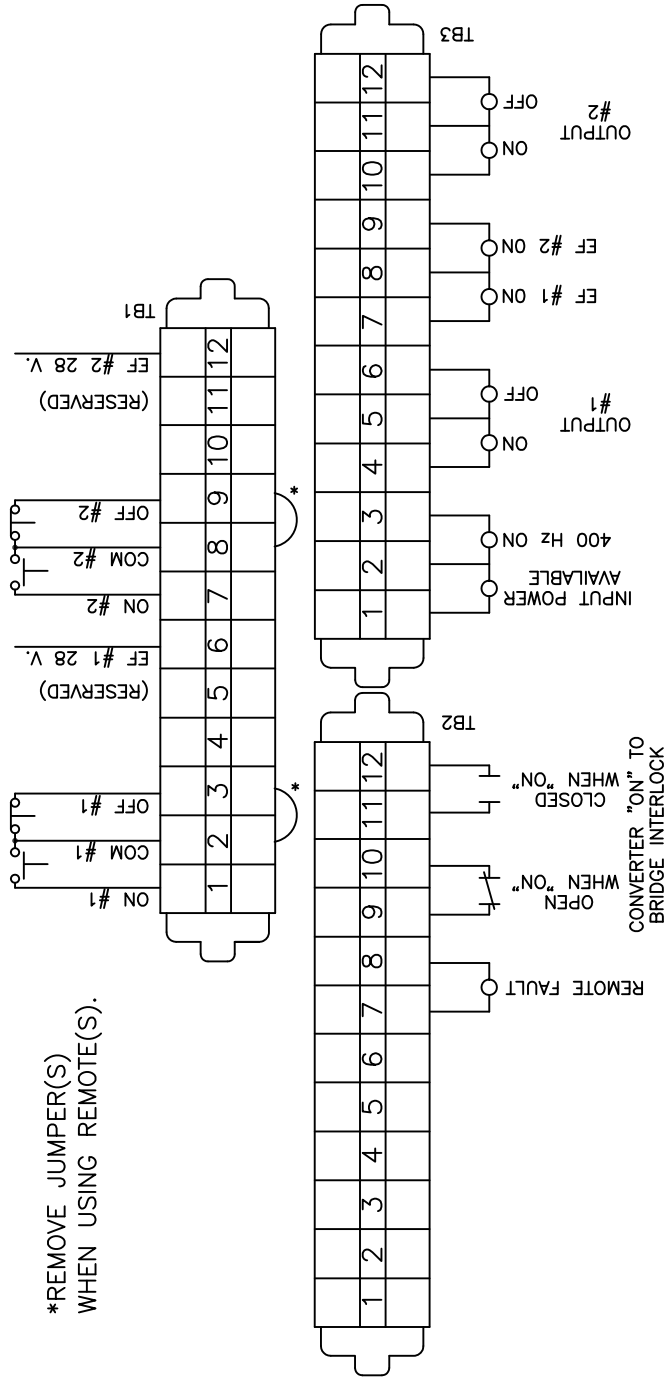

EF, REMOTES, & BRIDGE INTERLOCK CONNECTIONS

INPUT CABLE CONNECTIONS

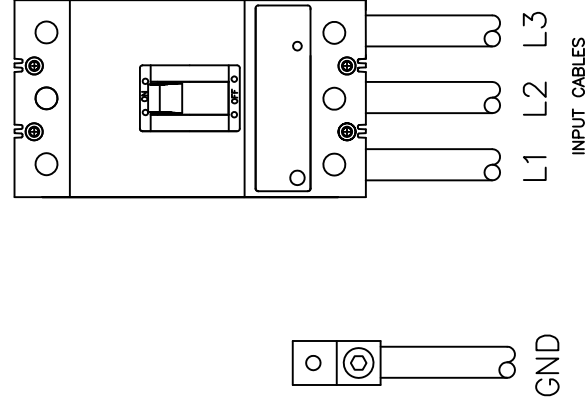

CONTACTOR CONNECTOR #6-350kcmil
3/8 ALLEN WRENCH REQUIRED

GROUND CONNECTOR #6-250mcm
5/16 OR MB ALLEN WRENCH REQUIRED

13mm SOCKET WITH EXTENSION FOR
CABLE CLAMP REQUIRED

CHANGE RECORD	DATE	FILE NAME	PLOT DATE	FINISH CODE PER 910176:	ACTIVITY	REPLACED BY	REPLACES
1	N/A	286495S3	5/2/03	UNLESS OTHERWISE SPECIFIED	MATERIAL NO.	QUANTITY-LIN	COMM. CLE.
2	N/A			UNLESS OTHERWISE SPECIFIED			
3	N/A			UNLESS OTHERWISE SPECIFIED			
4	N/A			UNLESS OTHERWISE SPECIFIED			
5	N/A			UNLESS OTHERWISE SPECIFIED			
6	N/A			UNLESS OTHERWISE SPECIFIED			
7	N/A			UNLESS OTHERWISE SPECIFIED			
8	28498A	1/2/02		UNLESS OTHERWISE SPECIFIED			
9	30988A	5/2/03		UNLESS OTHERWISE SPECIFIED			

OUTLINE, DIMENSIONAL	DESCRIPTION DATA	UNIT	SCALE
1	ADV CONVERTER	MM	1/2/02
2	APPROVED	MM	1/2/02
3	APPROVED	MM	1/2/02
4	APPROVED	MM	1/2/02
5	APPROVED	MM	1/2/02
6	APPROVED	MM	1/2/02
7	APPROVED	MM	1/2/02
8	APPROVED	MM	1/2/02
9	APPROVED	MM	1/2/02

CONFIDENTIAL	SIZE	REV. NO.	SHEET
THIS DRAWING, INCLUDING ALL INFORMATION CONTAINED THEREIN, IS THE EXCLUSIVE AND CONFIDENTIAL PROPERTY OF HOBART. IT IS NOT TO BE REPRODUCED, COPIED, OR DISCLOSED TO OTHERS, IN WHOLE OR IN PART, WITHOUT THE EXPRESS WRITTEN PERMISSION OF HOBART.	D	3	3 OF 3

HOBBART	SIZE	REV. NO.	SHEET
TROY, OHIO 45373 U.S.A.	D	3	3 OF 3

AIRCRAFT CABLE CONNECTIONS FOR 1 OR 2 OUTPUT UNITS

Appendix A Options / Features

The following is a list of options/features available for the 400 Hz. Solid State Converter. This chart contains the description, part number, and document number (if applicable) of the option/feature. There is also a column to identify which option/feature document is contained in this Appendix.

Option/Features Available			
Description	Part Number	Document Number	In This Section
2 Station Pushbutton Kit	285440-001	TO-278	
4 Station Pushbutton Kit	285440-002	TO-278	
SCR Diode Replacement Kit	286501-001	TO-261	
IGBT Transistor Replacement Kit	286502-001	TO-262	
Fan Impeller Replacement Kit	286548	NA	

* – A large number of variations exist under this part number. Call the factory for details.

This page intentionally left blank.

Unusual Service Conditions

This information is a general guideline and cannot cover all possible conditions of equipment use. The specific local environments may be dependent upon conditions beyond the manufacturer's control. The manufacturer should be consulted if any unusual conditions of use exist which may affect the physical condition or operation of the equipment or safety to surrounding personnel.

Among such conditions are:

1) Exposure to:

- a) Combustible, explosive, abrasive or conducting dusts.
- b) Environments where the accumulation of lint or excessive dirt will interfere with normal ventilation.
- c) Chemical fumes, flammable, or explosive gases.
- d) Nuclear radiation.
- e) Steam, salt-laden air, or oil vapor.
- f) Damp or very dry locations, radiant heat, vermin infestation, or atmospheres conducive to fungus growth.
- g) Abnormal shock, vibration or mechanical loading from external sources during equipment operation.
- h) Abnormal axial or side thrust imposed on rotating equipment shafts.
- i) Low and/or high ambient temperatures.
- j) High electromagnetic fields

2) Operation at:

- a) Voltages above or below rated voltage.
- b) Speeds other than rated speed.
- c) Frequency other than rated frequency.
- d) Standstill with rotating equipment windings energized.
- e) Unbalanced voltages.
- f) Operation at loads greater than rated.

3) Operation where low acoustical noise levels are required.

4) Operation with:

- a) Improper fuel, lubricants or coolant.
- b) Parts or elements unauthorized by the manufacturer.
- c) Unauthorized modifications.

5) Operation in poorly ventilated areas.