

---

Town of Silt, Colorado  
Financial Statements and  
Independent Auditor's Report  
as of  
December 31, 2016

---



**RECEIVED**

*By the Office of the State Auditor at 9:28 am, Sep 27, 2017*

**Town of Silt**  
**Table of Contents**

---

	<u>Page</u>
Independent Auditor's Report.....	1
Management's Discussion and Analysis.....	3
<b>Basic Financial Statements:</b>	
<b>Government-wide Financial Statements:</b>	
Statement of Net Position.....	12
Statement of Activities.....	13
<b>Fund Financial Statements:</b>	
Governmental Funds Balance Sheet.....	14
Reconciliation of the Governmental Funds Balance Sheet to the Statement of Net Position.....	15
Governmental Funds Statement of Revenues, Expenditures and Changes in Fund Balances.....	16
Reconciliation of the Governmental Funds Statement of Revenues, Expenditures and Changes in Fund Balances to the Statement of Activities.....	17
Statement of Net Position-Enterprise Funds.....	18
Statement of Revenues, Expenses and Changes in Net Position-Enterprise Funds.....	19
Statement of Cash Flows-Enterprise Funds.....	20
Notes to Basic Financial Statements.....	21
<b>Required Supplementary Information</b>	
Schedule of Changes in Net Pension Asset.....	38
Schedule of Contributions to Pension Plan.....	39
Statement of Revenues, Expenditures and Changes in Fund Balances-Budget and Actual:	
General Fund.....	40
Park Impact Fee Fund.....	41
<b>Other Supplementary Information</b>	
Combining Balance Sheet-Nonmajor Governmental Funds.....	42
Combining Statement of Revenues, Expenditures and Changes in Fund Balances-Nonmajor Governmental Funds.....	43
Statement of Revenues, Expenditures, and Changes in Fund Balances-Budget and Actual-Governmental Funds:	
Conservation Trust.....	44
Construction Impact Fee Fund.....	45
Victim Assistance Fund.....	46
Beautification Fund.....	47
Mountain Valley Development Fund.....	48
Schedules of Revenues, Expenditures and Changes in Available Resources-Budget and Actual-Enterprise Funds:	
Water Fund.....	49
Irrigation Fund.....	50
Housing Authority Fund.....	51
Economic Development Fund.....	52
Local Highway Finance Report.....	53

Blair

and

Associates P.C.

CERTIFIED PUBLIC ACCOUNTANTS AND CONSULTANTS

INDEPENDENT AUDITOR'S REPORT

Honorable Mayor and Town Council  
Town of Silt, Colorado

### **Report on the Financial Statements**

We have audited the accompanying financial statements of the governmental activities, the business-type activities, each major fund, and the aggregate remaining fund information of Town of Silt, Colorado, as of and for the year ended December 31, 2016, and the related notes to the financial statements, which collectively comprise the Town's basic financial statements as listed in the table of contents.

### ***Management's Responsibility for the Financial Statements***

Management is responsible for the preparation and fair presentation of these financial statements in accordance with accounting principles generally accepted in the United States of America; this includes the design, implementation, and maintenance of internal control relevant to the preparation and fair presentation of financial statements that are free from material misstatement, whether due to fraud or error.

### ***Auditor's Responsibility***

Our responsibility is to express opinions on these financial statements based on our audit. We conducted our audit in accordance with auditing standards generally accepted in the United States of America. Those standards require that we plan and perform the audit to obtain reasonable assurance about whether the financial statements are free from material misstatement.

An audit involves performing procedures to obtain audit evidence about the amounts and disclosures in the financial statements. The procedures selected depend on the auditor's judgment, including the assessment of the risks of material misstatement of the financial statements, whether due to fraud or error. In making those risk assessments, the auditor considers internal control relevant to the entity's preparation and fair presentation of the financial statements in order to design audit procedures that are appropriate in the circumstances, but not for the purpose of expressing an opinion on the effectiveness of the entity's internal control. Accordingly, we express no such opinion. An audit also includes evaluating the appropriateness of accounting policies used and the reasonableness of significant accounting estimates made by management, as well as evaluating the overall presentation of the financial statements.

We believe that the audit evidence we have obtained is sufficient and appropriate to provide a basis for our audit opinions.

### ***Opinions***

In our opinion, the financial statements referred to above present fairly, in all material respects, the respective financial position of the governmental activities, the business-type activities, each major fund, and the aggregate remaining fund information of the Town of Silt, Colorado, as of December 31, 2016, and the respective changes in financial position, and, where applicable, cash flows thereof for the year then ended in accordance with accounting principles generally accepted in the United States of America.

***Other Matters***

***Required Supplementary Information***

Accounting principles generally accepted in the United States of America require that the management's discussion and analysis, schedule of changes in net pension asset, schedule of contributions to pension plan and budgetary comparison information on pages 3-11, 38, 39 and 40-41 be presented to supplement the basic financial statements. Such information, although not a part of the basic financial statements, is required by the Governmental Accounting Standards Board, who considers it to be an essential part of financial reporting for placing the basic financial statements in an appropriate operational, economic, or historical context. We have applied certain limited procedures to the required supplementary information in accordance with auditing standards generally accepted in the United States of America, which consisted of inquiries of management about the methods of preparing the information and comparing the information for consistency with management's responses to our inquiries, the basic financial statements, and other knowledge we obtained during our audit of the basic financial statements. We do not express an opinion or provide any assurance on the information because the limited procedures do not provide us with sufficient evidence to express an opinion or provide any assurance.

***Other Information***

Our audit was conducted for the purpose of forming opinions on the financial statements that collectively comprise the Town of Silt, Colorado's basic financial statements. The Combining Statements for the nonmajor governmental funds, Statement of Revenues, Expenditures and Changes in Fund Balance Budget to Actual for the Governmental Funds, Schedules of Revenues, Expenditures and Changes in Available Resources-Budget and Actual-Enterprise Funds and local highway finance report are presented for purposes of additional analysis and are not a required part of the basic financial statements.

The Combining Statements for the nonmajor governmental funds, Statement of Revenues, Expenditures and Changes in Fund Balance Budget to Actual for the Governmental Funds, Schedules of Revenues, Expenditures and Changes in Available Resources-Budget and Actual-Enterprise Funds and local highway finance report are the responsibility of management and were derived from and relate directly to the underlying accounting and other records used to prepare the basic financial statements. Such information has been subjected to the auditing procedures applied in the audit of the basic financial statements and certain additional procedures, including comparing and reconciling such information directly to the underlying accounting and other records used to prepare the basic financial statements or to the basic financial statements themselves, and other additional procedures in accordance with auditing standards generally accepted in the United States of America. In our opinion, the Combining Statements for the nonmajor governmental funds, Statement of Revenues, Expenditures and Changes in Fund Balance Budget to Actual for the Governmental Funds, Schedules of Revenues, Expenditures and Changes in Available Resources-Budget and Actual-Enterprise Funds and local highway finance report are fairly stated in all material respects in relation to the basic financial statements as a whole.

*Blair and Associates, P.C.*

Cedaredge, Colorado  
August 22, 2017



**TOWN OF SILT**  
**Management's Discussion and Analysis**  
**Fiscal Year Ended December 31, 2016**

As management of the Town of Silt (the "Town"), we offer readers of the Town's basic financial statements this narrative overview and analysis of the financial activities of the Town for the fiscal year ended December 31, 2016. We encourage readers to consider the information presented here in conjunction with additional information provided in the financial statements.

**FINANCIAL HIGHLIGHTS**

- The Town's assets exceeded its liabilities by \$ 16,287,723 (i.e. net position) as of December 31, 2016, an increase of \$ 1,194,289 in comparison to the prior year.
- Governmental funds reported combined ending fund balances of \$ 1,884,227, an increase of \$ 41,180 in comparison with the prior year.
- The Town's fund balance for the General Fund was \$ 1,509,096, an increase of \$ 289 in comparison to the prior year.
- Total long-term liabilities decreased by \$ 354,793 during the 2016 fiscal year with no new debt issued.
- General property tax, sales tax, and other tax totaled \$ 1,419,873 or 87% of general revenues.

**OVERVIEW OF FINANCIAL STATEMENTS**

This discussion and analysis is intended to serve as an introduction to the Town's basic financial statements. The basic statements are comprised of three components: 1) government-wide financial statements, 2) fund financial statements, and 3) notes to the financial statements.

**Government-wide Financial Statements**

The government-wide financial statements are designed to provide readers with a broad overview of the Town's finances in a manner similar to a private-sector business.

The statement of net position presents information on all the Town's assets and liabilities and deferred inflow of resources, with the difference reported as net position. Over time, the increases or decreases in net position may serve as a useful indicator of whether the financial position of the Town is improving or deteriorating.

The statement of activities presents information showing how the Town's net position changed during the most recent fiscal year. All changes in net position are reported as soon as the underlying event giving rise to the change occurs, regardless of the timing of related cash flows. Thus, revenues and expenses reported in this statement for some items will result in cash flows in future periods (e.g. uncollected taxes and earned but unused personal time).

The government-wide financial statements distinguish functions of the Town that are principally supported by taxes and intergovernmental revenues (Governmental Activities) from other functions that are intended to recover all or a significant portion of their costs through user fees and charges (Business-type Activities).

The Governmental Activities of the Town include general government administration, public safety, public works, and parks and recreation. The Business-type Activities of the Town include the following utilities: Water/Wastewater, Irrigation, and Silt Housing Authority Funds.

### ***Fund Financial Statements***

A fund is a grouping of related accounts that is used to maintain control over resources that have been segregated for specific activities or objectives. Fund accounting is used to ensure and demonstrate compliance with finance-related legal requirements. The Town's funds can be divided into two categories: Governmental Funds and Proprietary Funds.

***Governmental Funds*** – Governmental funds are used to account for essentially the same functions reported as governmental activities in the government-wide financial statements. However, unlike the government-wide financial statements, governmental fund financial statements focus on short-term inflows and outflows of spendable resources, as well as on balances of spendable resources available at the end of the fiscal year. Such information may be useful in evaluating a government's short-term financing requirements. The accounting method is called modified accrual accounting.

Because the focus of governmental funds is narrower than that of the government-wide financial statements, it is useful to compare the information presented for governmental activities in the governmental funds with similar information presented for governmental activities in the government-wide financial statements. By doing so, readers may better understand the long-term impact of the government's short-term financing decisions. Both the governmental fund balance sheet and the governmental fund statement of revenues, expenditures, and changes in fund balances provide a reconciliation to facilitate this comparison between governmental funds and governmental activities.

The Town maintains two major government funds, the General Fund and the Park Impact Fee Fund. Information is presented separately in the governmental fund balance sheet and in the governmental fund statement of revenues, expenditures, and changes in fund balances for the general fund.

***Proprietary Funds*** – The Town maintains one type of proprietary fund. Enterprise Funds are used to report the same functions presented as business-type activities in the government-wide financial statements. The Town uses a separate enterprise fund to account for each of its funds: Water/Wastewater, Irrigation, and Silt Housing Authority Funds.

### ***Notes to Financial Statements***

The notes provide additional information that is essential to a full understanding of the data provided in the financial statements.

**GOVERNMENT-WIDE FINANCIAL ANALYSIS**

***Net Position***

As noted previously, net position may serve over time as a useful indicator of the Town’s financial position. For the year ended December 31, 2016, the Town’s combined assets exceeded liabilities and deferred inflow of resources by \$ 16,287,723. Of this amount, \$ 4,921,736 is unrestricted and available to meet the Town’s ongoing financial obligations.

By far the largest portion of net position is the investment in capital assets (net of related debt) of \$11,285,834 (69% of net assets). This amount reflects the investment in all capital assets (e.g. infrastructure, land, buildings, and equipment) less any related debt used to acquire those assets that are still outstanding. These capital assets are used to provide services to citizens; consequently, these assets are not available for future spending. Although the investment in capital assets is reported net of debt, it should be noted that the resources needed to repay this debt must be provided from other sources since capital assets themselves cannot be used to liquidate these liabilities.

The following table summarizes the Town’s governmental and business-type net assets for 2016:

	Governmental Activities		Business Type Activities		Totals	
	2016	2015	2016	2015	2016	2015
Assets						
Current and other assets	\$ 2,446,314	\$ 2,393,203	\$ 3,648,320	\$ 3,465,166	\$ 6,094,634	\$ 5,858,369
Capital assets	5,650,369	4,893,398	8,887,424	8,973,639	14,537,793	13,867,037
Total assets	<u>8,096,683</u>	<u>7,286,601</u>	<u>12,535,744</u>	<u>12,438,805</u>	<u>20,632,427</u>	<u>19,725,406</u>
Deferred outflows	127,237	38,305	-	-	-	38,305
Current liabilities	303,411	209,315	109,274	49,274	412,685	258,589
Non-current liabilities	13,745	50,384	4,195,179	4,504,823	4,208,924	4,555,207
Total liabilities	<u>317,156</u>	<u>259,699</u>	<u>4,304,453</u>	<u>4,554,097</u>	<u>4,621,609</u>	<u>4,813,796</u>
Deferred inflow of resources	258,914	256,553	-	-	258,914	256,553
Net position						
Investment in capital assets, net of related debt	5,636,624	4,843,014	5,649,210	4,939,602	11,285,834	9,782,616
Restricted	70,872	77,838	9,281	11,587	80,153	89,425
Unrestricted	1,940,354	1,887,802	2,981,382	3,333,591	4,921,736	5,221,393
Total net position	<u>\$ 7,647,850</u>	<u>\$ 6,808,654</u>	<u>\$ 8,639,873</u>	<u>\$ 8,284,780</u>	<u>\$ 16,287,723</u>	<u>\$ 15,093,434</u>

An additional portion of net position, \$80,153, represents resources that are subject to external restrictions on how they may be used. The remaining balance of unrestricted net position, \$ 4,921,736 (30% of net position), may be used to meet the government’s ongoing obligations to citizens and creditors.

## Change in Net Position

Governmental and business-type activities increased the Town's net position by \$1,194,289 in 2016.

	Governmental Activities		Business Type Activities		Total	
	2016	2015	2016	2015	2016	2015
<b>Revenues</b>						
Program revenues						
Charges for services	\$ 463,299	\$ 401,915	\$ 1,996,354	\$ 1,937,574	\$ 2,459,653	\$ 2,339,489
Operating grants	176,684	205,026	-	-	176,684	205,026
Capital grants	841,093	-	418,543	383,554	1,259,636	383,554
General revenues						
Property taxes	256,926	201,666	-	-	256,926	201,666
Intergovernmental	161,770	471,521	-	-	161,770	471,521
Sales taxes and other	1,076,688	1,104,643	-	-	1,076,688	1,104,643
Franchise taxes	86,259	84,386	-	-	86,259	84,386
Miscellaneous	42,952	110,835	-	-	42,952	110,835
Interest income	7,953	6,991	11,421	8,150	19,374	15,141
Totals	<u>3,113,624</u>	<u>2,586,983</u>	<u>2,426,318</u>	<u>2,329,278</u>	<u>5,539,942</u>	<u>4,916,261</u>
<b>Expenses</b>						
General government	565,560	538,036	-	-	565,560	538,036
Public safety	684,741	683,690	-	-	684,741	683,690
Public works	702,571	890,972	2,071,225	2,045,374	2,773,796	2,936,346
Parks and recreation	321,556	183,507	-	-	321,556	183,507
Total expenses	<u>2,274,428</u>	<u>2,296,205</u>	<u>2,071,225</u>	<u>2,045,374</u>	<u>4,345,653</u>	<u>4,341,579</u>
Increase in net position	839,196	290,778	355,093	283,904	1,194,289	574,682
Beginning	<u>6,808,654</u>	<u>6,517,876</u>	<u>8,284,780</u>	<u>8,000,876</u>	<u>15,093,434</u>	<u>14,518,752</u>
Ending	<u>\$ 7,647,850</u>	<u>\$ 6,808,654</u>	<u>\$ 8,639,873</u>	<u>\$ 8,284,780</u>	<u>\$ 16,287,723</u>	<u>\$ 15,093,434</u>

1  
2  
3  
4  
5  
6  
7  
8  
9  
10  
11  
12  
13  
14  
15  
16  
17  
18  
19  
20  
21  
22  
23  
24  
25  
26  
27  
28  
29  
30  
31  
32  
33  
34  
35  
36  
37  
38  
39  
40  
41  
42  
43  
44  
45  
46  
47  
48  
49  
50  
51  
52  
53  
54  
55  
56  
57  
58  
59  
60  
61  
62  
63  
64  
65  
66  
67  
68  
69  
70  
71  
72  
73  
74  
75  
76  
77  
78  
79  
80  
81  
82  
83  
84  
85  
86  
87  
88  
89  
90  
91  
92  
93  
94  
95  
96  
97  
98  
99  
100

**Governmental Activities**

Governmental activities increased the Town's net position by \$ 839,196.

**Revenues by Source-Governmental Activities**

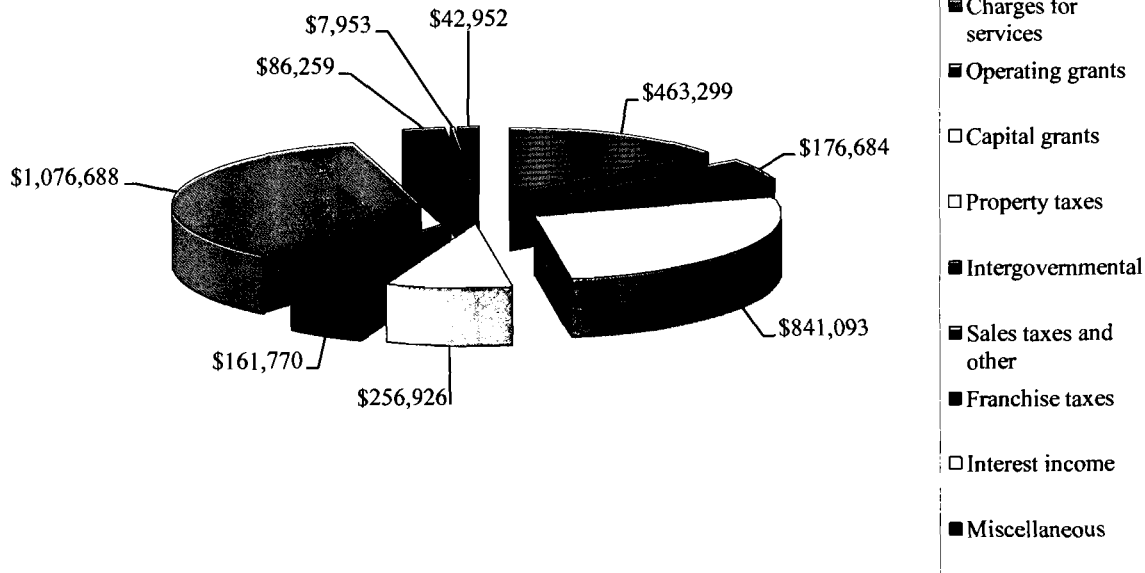

**Expenses by Department-Governmental Activities**

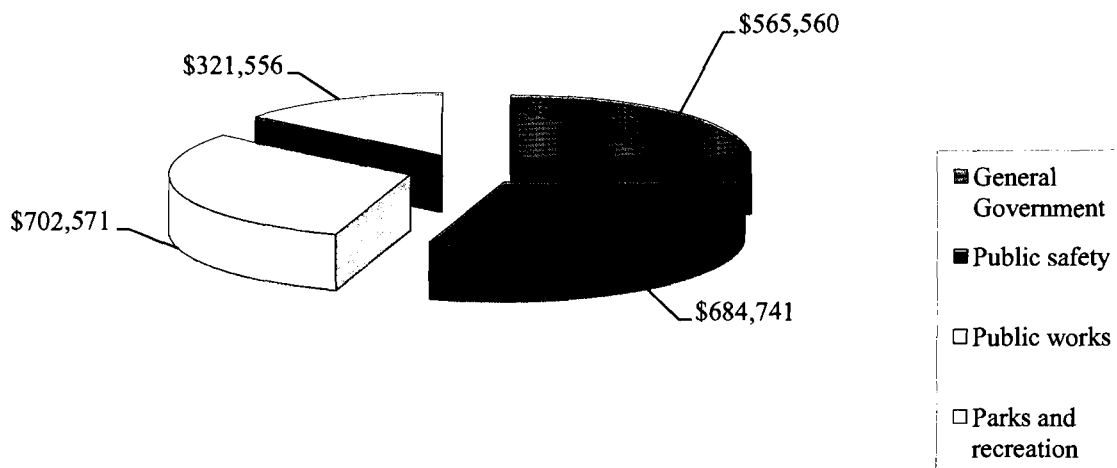

1  
2  
3  
4  
5  
6  
7  
8  
9  
10  
11  
12  
13  
14  
15  
16  
17  
18  
19  
20  
21  
22  
23  
24  
25  
26  
27  
28  
29  
30  
31  
32  
33  
34  
35  
36  
37  
38  
39  
40  
41  
42  
43  
44  
45  
46  
47  
48  
49  
50  
51  
52  
53  
54  
55  
56  
57  
58  
59  
60  
61  
62  
63  
64  
65  
66  
67  
68  
69  
70  
71  
72  
73  
74  
75  
76  
77  
78  
79  
80  
81  
82  
83  
84  
85  
86  
87  
88  
89  
90  
91  
92  
93  
94  
95  
96  
97  
98  
99  
100

***Business-type Activities***

Business-type activities for the year had an increase in net position of \$ 355,093. Charges for services accounted for 82% of total revenues.

**FINANCIAL ANALYSIS OF GOVERNMENT'S FUNDS**

***Governmental funds***

The focus of the Town's governmental funds is to provide information on near-term inflows, outflows, and balances of spendable resources. Such information is useful in assessing the Town's financing requirements. In particular, unreserved fund balance may serve as a useful measure of the Town's net resources available for spending at the end of the fiscal year.

As of the end of 2016, the Town's governmental funds reported combined ending fund balances of \$ 1,884,227, an increase of \$ 41,180 in comparison with the prior year. Of the combined ending fund balances for all governmental funds 76% of this total amount, \$ 1,438,224, constitutes unassigned fund balance, which is available for appropriation at the Town's discretion. The remainder of the fund balance is reserved to indicate that it is not available for new spending because it is already committed to meet a State constitution mandated emergency reserve \$70,872, reserve for parks and recreation \$ 137,553, reserve for beautification \$ 157,500, reserve for victim assistance \$ 59,868, and reserve for impact fees of \$ 20,210.

The Town has two major governmental funds, the General Fund, which is the primary operating fund for the Town, and the Park Impact Fee Fund. At the end of 2016, unassigned fund balance of the General Fund was \$ 1,438,224, while the total fund balance was \$ 1,509,096. As a measure of the General Fund's liquidity, it may be useful to compare both unreserved fund balance and total fund balance to total fund expenditures. The fund balance in the Town's General Fund increased by \$ 289 during 2016.

***Proprietary funds***

The Town's proprietary fund statements provide the same type of information found in the government-wide financial statements, but in more detail.

The Town has three enterprise funds: Water/Wastewater, Irrigation, and Silt Housing Authority Funds. At the end of 2016, these funds represented the following net position amounts:

	Water/ Wastewater	Irrigation	Silt Housing Authority
Unrestricted net position	\$ 2,229,168	\$ 568,547	\$ 183,667
Total net position	\$ 7,060,508	\$ 887,663	\$ 691,702
Increase (decrease) in net position	\$ 370,733	\$ (1,128)	\$ (14,512)

**GENERAL FUND BUDGETARY HIGHLIGHTS**

The Town budgeted \$ 3,173,643 for 2016 expenditures. Actual expenditures were \$ 3,005,796. There was one supplemental budget for 2016.

**CAPITAL ASSET AND DEBT ADMINISTRATION**

The Town's investment in capital assets for its governmental and business-type activities as of December 31, 2016, was \$ 14,973,865. As required by GASB 34, the investment in capital assets includes land, buildings, building improvements, and equipment.

	Balance January 1, 2016	Additions	Dispositions	Balance December 31, 2016
Governmental Activities				
Capital assets not being depreciated				
Land	\$ 1,786,219	\$ -	\$ -	\$ 1,786,219
	<u>1,786,219</u>	<u>-</u>	<u>-</u>	<u>1,786,219</u>
Capital assets being depreciated				
Buildings	842,164	-	-	842,164
Improvements/infrastructure	5,714,854	1,075,798	-	6,790,652
Machinery and equipment	687,097	12,617	-	699,714
	<u>7,244,115</u>	<u>1,088,415</u>	<u>-</u>	<u>8,332,530</u>
Less accumulated depreciation				
Buildings	(641,222)	(39,308)	-	(680,530)
Improvements/infrastructure	(3,119,656)	(226,823)	-	(3,346,479)
Machinery and equipment	(376,058)	(65,313)	-	(441,371)
	<u>(4,136,936)</u>	<u>(331,444)</u>	<u>-</u>	<u>(4,468,380)</u>
Capital asset being depreciated, net	<u>3,107,179</u>	<u>756,971</u>	<u>-</u>	<u>3,864,150</u>
Total Governmental Activities Capital Assets	<u>\$ 4,893,398</u>	<u>\$ 756,971</u>	<u>\$ -</u>	<u>\$ 5,650,369</u>



	Balance January 1, 2016	Additions	Dispositions	Balance December 31, 2016
<b>Business - Type Activities</b>				
Capital assets not being depreciated				
Land	\$ 436,072	\$ -	\$ -	\$ 436,072
Capital assets being depreciated				
Treatment plants	7,832,881	-	-	7,832,881
Distribution system	3,379,465	313,215	-	3,692,680
Irrigation system	1,191,175	-	-	1,191,175
Buildings	1,032,385	-	-	1,032,385
Machinery and equipment	227,029	-	-	227,029
Less accumulated depreciation	(4,689,296)	(399,430)	-	(5,088,726)
Capital assets being depreciated, net	<u>8,973,639</u>	<u>(86,215)</u>	<u>-</u>	<u>8,887,424</u>
<b>Total Business-Type Activities Capital Assets</b>	<u>\$ 9,409,711</u>	<u>\$ (86,215)</u>	<u>\$ -</u>	<u>\$ 9,323,496</u>

#### Long-term Debt

As of December 31, 2016, the Town had long-term debt as follows:

	Balance January 1, 2016	Additions	Reductions	Balance December 31, 2016	Due within one year
<b>Governmental Activities</b>					
Lease payable	\$ 50,384	\$ -	\$ (36,638)	\$ 13,746	\$ 4,414
Total	<u>\$ 50,384</u>	<u>\$ -</u>	<u>\$ (36,638)</u>	<u>\$ 13,746</u>	<u>\$ 4,414</u>
<b>Enterprise Activities</b>					
Bonds payable-Series 2012	\$ 4,475,000	\$ -	\$ (300,000)	\$ 4,175,000	\$ 300,000
Contract payable	29,823	-	(9,644)	20,179	9,938
Lease payable	36,000	-	(8,510)	27,490	8,828
Total	<u>\$ 4,540,823</u>	<u>\$ -</u>	<u>\$ (318,154)</u>	<u>\$ 4,222,669</u>	<u>\$ 318,766</u>

## **ECONOMIC AND OTHER FACTORS**

Today's challenging economic environment has affected the Town, but perhaps not as severely as it has in other parts of the state or nation. The General Fund Sales Tax increased 9.2%. Property assessments remained flat and Use Tax revenue collected came in at our projected budget.

The Town continues to be successful with grant awards to assist with infrastructure improvements. The Town has relied heavily on Garfield County Federal Mineral Lease District, Associated Governments of Northwestern Colorado, the Department of Local Affairs, the Colorado Water Conservation Board and Garfield County, in order to meet the Town's improvement needs in the past several years.

The number one goal of the Board of Trustees is to develop a viable downtown business district, supplemented in outlying areas, by marketing a quality shopping center and increasing the Town's diverse industrial mix that will translate into job opportunities and an expanded tax base. The Board of Trustees and Town staff will continue to operate with goals of efficiency and effectiveness while maintaining high service levels for health, safety, welfare and comfort of the citizens of Silt.

## **CONTACTING THE TOWN'S FINANCIAL MANAGEMENT**

This financial report is designed to provide the general public with a general overview of the Town's finances and to show the Town's accountability for the money it receives. If you have any questions regarding this report or need additional financial information, please contact:

Town Administrator/Treasurer  
Pamela K. Woods  
Town of Silt  
231 North 7<sup>th</sup> Street  
P.O. Box 70  
Silt, Colorado 81652  
Tel: (970) 876-2353  
Fax: (970) 876-2937

1  
2  
3  
4  
5  
6  
7  
8  
9  
10  
11  
12  
13  
14  
15  
16  
17  
18  
19  
20  
21  
22  
23  
24  
25  
26  
27  
28  
29  
30  
31  
32  
33  
34  
35  
36  
37  
38  
39  
40  
41  
42  
43  
44  
45  
46  
47  
48  
49  
50  
51  
52  
53  
54  
55  
56  
57  
58  
59  
60  
61  
62  
63  
64  
65  
66  
67  
68  
69  
70  
71  
72  
73  
74  
75  
76  
77  
78  
79  
80  
81  
82  
83  
84  
85  
86  
87  
88  
89  
90  
91  
92  
93  
94  
95  
96  
97  
98  
99  
100

**TOWN OF SILT, COLORADO**  
**Statement of Net Position**  
**December 31, 2016**

	<b>Governmental Activities</b>	<b>Business- Type Activities</b>	<b>Total</b>
<b>ASSETS</b>			
Cash and cash equivalents	\$ 1,899,923	\$ 2,080,955	\$ 3,980,878
Restricted Cash	-	591,691	591,691
Property taxes receivable	257,360	-	257,360
Customer Accounts Receivables	169,523	256,268	425,791
Other receivables	10,339	-	10,339
Due from other governments	248,984	-	248,984
Inventories	693	9,281	9,974
Interfund balances	(141,824)	141,824	-
Water Share	-	391,921	391,921
Bond issue costs, net	-	112,094	112,094
Bond Premium, net	-	64,286	64,286
Net pension assets	1,316	-	1,316
Capital assets, net	5,650,369	8,887,424	14,537,793
<b>Total assets</b>	<b>8,096,683</b>	<b>12,535,744</b>	<b>20,632,427</b>
<b>DEFERRED OUTFLOWS</b>			
Pension contributions made after measurement date	28,950	-	28,950
Pension net difference between projected and actual investment earnings, change in assumptions and actual and expected experience	98,287	-	98,287
<b>Total Deferred outflows</b>	<b>127,237</b>	<b>-</b>	<b>127,237</b>
<b>LIABILITIES</b>			
Accrued Payroll	142,929	29,651	172,580
Accrued Expenses	125,665	61,342	187,007
Deposits and escrows	19,548	1,500	21,048
Unearned revenue	15,269	4,000	19,269
Accrued Interest	-	12,781	12,781
Noncurrent liabilities:			
Due within one year	4,414	309,938	314,352
Due more than one year:	9,331	3,885,241	3,894,572
<b>Total liabilities</b>	<b>317,156</b>	<b>4,304,453</b>	<b>4,621,609</b>
<b>Deferred inflows of resources</b>			
Deferred property taxes	257,360	-	257,360
Pension difference between expected and actual experience	1,554	-	1,554
<b>Total Deferred inflows of resources</b>	<b>258,914</b>	<b>-</b>	<b>258,914</b>
<b>NET POSITION</b>			
Invested in capital assets	5,636,624	5,649,210	11,285,834
Restricted for:			
Tabor	70,872	9,281	80,153
Unrestricted	1,940,354	2,981,382	4,921,736
<b>Total net position</b>	<b>\$ 7,647,850</b>	<b>\$ 8,639,873</b>	<b>\$ 16,287,723</b>

The accompanying notes are an integral part of this statement.

**TOWN OF SILT, COLORADO**  
**Statement of Activities**  
**For the Year Ended December 31, 2016**

Functions/Programs	Expenses	Program Revenues		
		Charges for Service and Fees	Operating Grants and Contributions	Capital Grants and Contributions
<b>Primary government:</b>				
<b>Governmental activities:</b>				
General government	\$ 565,560	\$ 348,578	\$ -	\$ -
Public Safety	684,741	31,957	19,379	-
Public Works	702,571	44,249	122,712	841,093
Parks and Recreation	321,556	38,515	34,593	-
<b>Total governmental activities</b>	<u>2,274,428</u>	<u>463,299</u>	<u>176,684</u>	<u>841,093</u>
<b>Business-type activities:</b>				
Water/Wastewater	1,636,744	1,628,309	-	413,613
Irrigation	264,929	213,798	-	4,930
Housing	169,552	154,247	-	-
<b>Total business-type activities</b>	<u>2,071,225</u>	<u>1,996,354</u>	<u>-</u>	<u>418,543</u>
<b>Total primary government</b>	<u>\$ 4,345,653</u>	<u>\$ 2,459,653</u>	<u>\$ 176,684</u>	<u>\$ 1,259,636</u>

**General Revenues**

Taxes:

Sales and Use tax

Property Tax

Franchise taxes

Other Tax

Intergovernmental

Unrestricted investment earnings

Miscellaneous

**Total General Revenues and Transfers**

**Changes in Net Position**

**Net Position-January 1**

**Net Position-December 31**

**TOWN OF SILT, COLORADO**  
**Statement of Activities**  
**For the Year Ended December 31, 2016**

Functions/Programs	Expenses	Program Revenues		
		Charges for Service and Fees	Operating Grants and Contributions	Capital Grants and Contributions
<b>Primary government:</b>				
<b>Governmental activities:</b>				
General government	\$ 565,560	\$ 348,578	\$ -	\$ -
Public Safety	684,741	31,957	19,379	-
Public Works	702,571	44,249	122,712	841,093
Parks and Recreation	321,556	38,515	34,593	-
<b>Total governmental activities</b>	<u>2,274,428</u>	<u>463,299</u>	<u>176,684</u>	<u>841,093</u>
<b>Business-type activities:</b>				
Water/Wastewater	1,636,744	1,628,309	-	413,613
Irrigation	264,929	213,798	-	4,930
Housing	169,552	154,247	-	-
<b>Total business-type activities</b>	<u>2,071,225</u>	<u>1,996,354</u>	<u>-</u>	<u>418,543</u>
<b>Total primary government</b>	<u>\$ 4,345,653</u>	<u>\$ 2,459,653</u>	<u>\$ 176,684</u>	<u>\$ 1,259,636</u>

**General Revenues**

Taxes:

Sales and Use tax

Property Tax

Franchise taxes

Other Tax

Intergovernmental

Unrestricted investment earnings

Miscellaneous

**Total General Revenues and Transfers**

**Changes in Net Position**

**Net Position-January 1**

**Net Position-December 31**

**Net (Expense) Revenue and Changes in Net Position**  
**Primary Government**

<b>Governmental Activities</b>	<b>Business-Type Activities</b>	<b>Total</b>
\$ (216,982)	\$ -	\$ (216,982)
(633,405)	-	(633,405)
305,483	-	305,483
(248,448)	-	(248,448)
<u>(793,352)</u>	<u>-</u>	<u>(793,352)</u>
-	405,178	405,178
-	(46,201)	(46,201)
-	(15,305)	(15,305)
<u>-</u>	<u>343,672</u>	<u>343,672</u>
<u>(793,352)</u>	<u>343,672</u>	<u>(449,680)</u>
1,017,223	-	1,017,223
256,926	-	256,926
86,259	-	86,259
59,465	-	59,465
161,770	-	161,770
7,953	11,421	19,374
42,952	-	42,952
<u>1,632,548</u>	<u>11,421</u>	<u>1,643,969</u>
839,196	355,093	1,194,289
6,808,654	8,284,780	15,093,434
<u>\$ 7,647,850</u>	<u>\$ 8,639,873</u>	<u>\$ 16,287,723</u>

The accompanying notes are an integral part of this statement.



**TOWN OF SILT, COLORADO**  
**Governmental Funds**  
**Balance Sheet**  
**December 31, 2016**

	<b>General Fund</b>	<b>Park Impact Fee Fund</b>	<b>Other Governmental Funds</b>	<b>Total Governmental Funds</b>
<b>Assets</b>				
Cash unrestricted	\$ 1,524,791	\$ 54,207	\$ 320,925	\$ 1,899,923
Taxes receivable	257,360	-	-	257,360
Inventory	693	-	-	693
Customer accounts receivable	27,700	-	141,823	169,523
Other receivables	10,339	-	-	10,339
Due from other Governments	248,984	-	-	248,984
<b>Total assets</b>	<u>\$ 2,069,867</u>	<u>\$ 54,207</u>	<u>\$ 462,748</u>	<u>\$ 2,586,822</u>
<b>Liabilities</b>				
Accounts Payable	\$ 95,753	\$ -	\$ -	\$ 95,753
Accrued Payroll	142,929	-	-	142,929
Accrued Expenses	29,912	-	-	29,912
Deposits and Escrows	19,548	-	-	19,548
Due to Other Funds	-	-	141,824	141,824
Unearned Revenue	15,269	-	-	15,269
<b>Total Liabilities</b>	<u>303,411</u>	<u>-</u>	<u>141,824</u>	<u>445,235</u>
<b>Deferred inflows of resources</b>				
Deferred property taxes	257,360	-	-	257,360
<b>Total Deferred inflows of resources</b>	<u>257,360</u>	<u>-</u>	<u>-</u>	<u>257,360</u>
<b>Fund Balance</b>				
<b>Restricted</b>				
Tabor emergencies	70,872	-	-	70,872
Parks and recreation	-	54,207	83,346	137,553
<b>Committed</b>				
Beautification	-	-	157,500	157,500
<b>Assigned</b>				
Impact fees	-	-	20,210	20,210
Victim Assistance	-	-	59,868	59,868
<b>Unassigned</b>	<u>1,438,224</u>	<u>-</u>	<u>-</u>	<u>1,438,224</u>
<b>Total Fund Equity</b>	<u>1,509,096</u>	<u>54,207</u>	<u>320,924</u>	<u>1,884,227</u>
<b>Total Liabilities, deferred inflows of resources and fund equity</b>	<u>\$ 2,069,867</u>	<u>\$ 54,207</u>	<u>\$ 462,748</u>	<u>\$ 2,586,822</u>

The accompanying notes are an integral part of this statement.



**TOWN OF SILT, COLORADO**  
**Reconciliation of the Governmental Funds Balance**  
**Sheet to the Statement of Net Position**  
**December 31, 2016**

---

**Total fund balance, governmental funds** \$ 1,884,227

Amounts reported for governmental activities in the Statement of Net Position is different because:

Capital assets used in governmental activities are not current period expenditures and therefore are not reported in this fund financial statement, but are reported in the governmental activities of the Statement of Net Position.

Cost of capital assets	\$ 10,118,749	
Less accumulated depreciation	<u>(4,468,380)</u>	5,650,369

Some liabilities, (such as Notes Payable, Capital Lease Contract Payable, Long-term Compensated Absences, and Bonds Payable), are not due and payable in the current period and are not included in the fund financial statement, but are included in the governmental activities of the Statement of Net Position.

Capital leases	(13,745)
----------------	----------

Net pension assets and related deferred inflows and outflows of resources are not recorded in the funds.	126,999
--	---------

<b>Net Position of Governmental Activities in the Statement of Net Position</b>	<b>\$ 7,647,850</b>
---	---------------------

**The accompanying notes are an integral part of this statement.**



**TOWN OF SILT, COLORADO**  
**Statement of Revenues, Expenditures and Changes in Fund Balances**  
**Governmental Funds**  
**For the Year Ended December 31, 2016**

	<b>General Fund</b>	<b>Park Impact Fee Fund</b>	<b>Nonmajor Governmental Funds</b>	<b>Total Governmental Funds</b>
<b>REVENUES</b>				
Taxes	\$ 1,356,220	\$ -	\$ 47,200	\$ 1,403,420
Intergovernmental	300,936	-	-	300,936
Operating Grant and Contributions	861,472	-	49,878	911,350
Licenses/Permits	57,966	-	-	57,966
Charges for services	301,483	-	-	301,483
Fines and Fees	22,411	-	5,100	27,511
Impact Fees	-	6,805	6,689	13,494
Interest	7,830	41	82	7,953
Administration Fees	30,290	-	-	30,290
Miscellaneous	59,221	-	-	59,221
<b>Total revenues</b>	<u>2,997,829</u>	<u>6,846</u>	<u>108,949</u>	<u>3,113,624</u>
<b>EXPENDITURES</b>				
Current:				
General government	531,357	-	17,017	548,374
Public safety	642,167	-	760	642,927
Public works	495,335	-	-	495,335
Parks and Recreation	274,084	30,000	-	304,084
Capital outlay	1,024,917	-	18,871	1,043,788
Debt Service:				
Principal	36,639	-	-	36,639
Interest	1,297	-	-	1,297
<b>Total expenditures</b>	<u>3,005,796</u>	<u>30,000</u>	<u>36,648</u>	<u>3,072,444</u>
<b>Excess (deficiency) of revenues over expenditures</b>	(7,967)	(23,154)	72,301	41,180
<b>Fund balance, January 1</b>	1,508,807	77,361	256,879	1,843,047
<b>Residual transfer</b>	8,256	-	(8,256)	-
<b>Fund balance, December 31</b>	<u>\$ 1,509,096</u>	<u>\$ 54,207</u>	<u>\$ 320,924</u>	<u>\$ 1,884,227</u>

The accompanying notes are an integral part of this statement.



**TOWN OF SILT, COLORADO**  
**Reconciliation of the Governmental Funds Statement of Revenues, Expenditures,**  
**and Changes in Fund Balances to the Statement of Activities**  
**For the Year Ended December 31, 2016**

---

**Net change in fund balances - total governmental funds** \$ 41,180

Amounts reported for governmental activities in the statement of activities are different because:

Governmental funds report capital outlays as expenditures. However, in the statement of activities the cost of those assets is allocated over their estimated useful lives and reported as depreciation expense. This is the amount by which depreciation exceeded capital outlays in the current period.

Fixed assets current additions	\$ 1,088,415	
Depreciation expense	(331,444)	
Excess of capital outlay over depreciation	756,971	756,971

Repayment of long-term debt principal is reported as an expenditure in the governmental funds but reduces long-term liabilities in the statement of net position.		36,639
---	--	--------

Pension expenses not in current year		4,406
--------------------------------------	--	-------

<b>Change in net position of governmental funds</b>		<b>\$ 839,196</b>
---	--	-------------------

**The accompanying notes are an integral part of this statement.**

**TOWN OF SILT, COLORADO**  
**Statement of Net Position**  
**Enterprise Funds**  
**December 31, 2016**

	<u>Water Wastewater</u>	<u>Irrigation</u>	<u>Silt Housing Authority</u>	<u>Total Enterprise Funds</u>
<b>ASSETS</b>				
<b>Current Assets:</b>				
Cash	\$ 1,335,868	\$ 550,117	\$ 194,970	\$ 2,080,955
Restricted Cash	591,691	-	-	591,691
Interfund Note Receivable	19,918	-	-	19,918
Accounts receivable, net	375,444	22,648	-	398,092
Inventories	9,281	-	-	9,281
<b>Total current assets</b>	<u>2,332,202</u>	<u>572,765</u>	<u>194,970</u>	<u>3,099,937</u>
<b>Capital assets:</b>				
Water Shares	362,745	29,176	-	391,921
Bond issuance cost, net	112,094	-	-	112,094
Bond Premium, net	64,286	-	-	64,286
Land	281,952	-	154,120	436,072
Property, plant and Equipment	11,742,782	1,192,723	1,040,645	13,976,150
Less accumulated depreciation	<u>(3,532,876)</u>	<u>(869,120)</u>	<u>(686,730)</u>	<u>(5,088,726)</u>
<b>Total capital assets</b>	<u>9,030,983</u>	<u>352,779</u>	<u>508,035</u>	<u>9,891,797</u>
<b>Total Assets</b>	<u>\$11,363,185</u>	<u>\$ 925,544</u>	<u>\$ 703,005</u>	<u>\$12,991,734</u>
<b>LIABILITIES</b>				
<b>Current liabilities:</b>				
Accounts payable	\$ 50,689	\$ 49	\$ -	\$ 50,738
Deposits	1,500	-	-	1,500
Accrued payroll	24,396	4,169	1,086	29,651
Accrued Interest	12,781	-	-	12,781
Other Accrued Liabilities	387	-	10,217	10,604
Unearned revenues	4,000	-	-	4,000
Current maturities of long term debt				
Bonds Payable	300,000	-	-	300,000
Notes Payable	9,938	-	-	9,938
Lease Payable	4,414	4,414	-	8,828
<b>Total current liabilities</b>	<u>408,105</u>	<u>8,632</u>	<u>11,303</u>	<u>419,212</u>
<b>Noncurrent Liabilities</b>				
Bonds payable	3,875,000	-	-	3,875,000
Notes Payable	10,241	-	-	10,241
Lease Payable	9,331	9,331	-	18,662
Interfund Note Payable	-	19,918	-	19,918
<b>Total noncurrent liabilities</b>	<u>3,894,572</u>	<u>29,249</u>	<u>-</u>	<u>3,923,821</u>
<b>Net Position</b>				
Invested in capital assets, net of related debt	4,822,059	319,116	508,035	5,649,210
Reserved for Inventory	9,281	-	-	9,281
Unrestricted	2,229,168	568,547	183,667	2,981,382
<b>Total Net Position</b>	<u>\$ 7,060,508</u>	<u>\$ 887,663</u>	<u>\$ 691,702</u>	<u>\$ 8,639,873</u>

**TOWN OF SILT, COLORADO**  
**Statement of Revenues, Expenses and Changes in Net Position**  
**Enterprise Funds**  
**Year Ended December 31, 2016**

	<b>Water</b>		<b>Silt Housing</b>	
	<b>Wastewater</b>	<b>Irrigation</b>	<b>Authority</b>	<b>Total</b>
<b>Operating Revenues</b>				
Charges for services	\$ 1,590,482	\$ 213,798	\$ 154,247	\$ 1,958,527
Other	37,827	-	-	37,827
<b>Total operating revenues</b>	<u>1,628,309</u>	<u>213,798</u>	<u>154,247</u>	<u>1,996,354</u>
<b>Operating Expenses</b>				
Operations	637,463	101,446	107,088	845,997
Administration	478,200	122,661	32,528	633,389
Depreciation	348,162	38,970	29,936	417,068
<b>Total operating expenses</b>	<u>1,463,825</u>	<u>263,077</u>	<u>169,552</u>	<u>1,896,454</u>
<b>Operating income (loss)</b>	<u>164,484</u>	<u>(49,279)</u>	<u>(15,305)</u>	<u>99,900</u>
<b>Nonoperating revenues (expenses)</b>				
Interest income	10,628	-	793	11,421
Interest expense	(172,919)	(1,852)	-	(174,771)
<b>Total nonoperating revenues (expenses)</b>	<u>(162,291)</u>	<u>(1,852)</u>	<u>793</u>	<u>(163,350)</u>
<b>Income (loss) before transfers and and Capital Contributions</b>	2,193	(51,131)	(14,512)	(63,450)
<b>Contributions and Transfers</b>				
Tap fees	170,411	4,930	-	175,341
Other grants and contributions	243,202	-	-	243,202
Transfers in (out)	(45,073)	45,073	-	-
<b>Total Contributions and Transfers</b>	<u>368,540</u>	<u>50,003</u>	<u>-</u>	<u>418,543</u>
<b>Change in net position</b>	370,733	(1,128)	(14,512)	355,093
<b>Total net position, January 1</b>	<u>6,689,775</u>	<u>888,791</u>	<u>706,214</u>	<u>8,284,780</u>
<b>Total net position, December 31</b>	<u>\$ 7,060,508</u>	<u>\$ 887,663</u>	<u>\$ 691,702</u>	<u>\$ 8,639,873</u>

**TOWN OF SILT, COLORADO**  
**Statement of Cash Flows**  
**Enterprise Funds**  
**Year Ended December 31, 2016**

	<b>Water Wastewater</b>	<b>Irrigation</b>	<b>Silt Housing Authority</b>	<b>Total Enterprise Funds</b>
<b>Cash Flows From Operating Activities</b>				
Cash received from customer and others	\$ 1,572,651	\$ 214,451	\$ 154,247	\$ 1,941,349
Cash payments for personnel	(634,952)	(100,544)	(106,860)	(842,356)
Cash payments for goods and services	(426,311)	(122,612)	(25,802)	(574,725)
<b>Net cash provided (used) by operating activities</b>	<u>511,388</u>	<u>(8,705)</u>	<u>21,585</u>	<u>524,268</u>
<b>Cash Flows from Noncapital Financing Activities</b>				
Transfers from (to) other funds	(45,073)	45,073	-	-
<b>Net cash provided (used) by noncapital financing activities</b>	<u>(45,073)</u>	<u>45,073</u>	<u>-</u>	<u>-</u>
<b>Cash Flows from Capital and Related Financing Activities</b>				
Receipt of capital contributions	413,613	4,930	-	418,543
Fixed Assets purchased, less gain on sale	(313,215)	-	-	(313,215)
Long term debt payment- principal	(313,899)	(4,255)	-	(318,154)
Long term debt payment- interest	(172,919)	(1,852)	-	(174,771)
<b>Net cash provided (used) by capital and related financing activities</b>	<u>(386,420)</u>	<u>(1,177)</u>	<u>-</u>	<u>(387,597)</u>
<b>Cash Flows from Investing Activities</b>				
Principal on long-term receivables	19,338	(19,338)	-	-
Interest on investments	10,628	-	793	11,421
<b>Net Cash provided by Investing Activities</b>	<u>29,966</u>	<u>(19,338)</u>	<u>793</u>	<u>11,421</u>
<b>Net increase (decrease) in cash and equivalents</b>	109,861	15,853	22,378	148,092
<b>Cash balances, January 1</b>	1,817,698	534,264	172,592	2,524,554
<b>Cash balances, December 31</b>	<u>\$ 1,927,559</u>	<u>\$ 550,117</u>	<u>\$ 194,970</u>	<u>\$ 2,672,646</u>
<b>Reconciliation of operating income (loss) to net cash provided (used) by operating activities:</b>				
Operating income (loss)	\$ 164,484	\$ (49,279)	\$ (15,305)	\$ 99,900
Adjustments to reconcile operating income (loss) to net cash provided (used) by operating activities:				
Depreciation expense	348,162	38,970	29,936	417,068
Assets (increase) decrease:				
Accounts receivables	(55,658)	653		(55,005)
Inventory	2,306	-		2,306
Liabilities increase (decrease):				
Accounts payable	49,583	49	-	49,632
Other accrued liabilities	-	-	6,726	6,726
Accrued payroll liabilities	2,511	902	228	3,641
Total adjustments	<u>346,904</u>	<u>40,574</u>	<u>36,890</u>	<u>424,368</u>
<b>Net cash provided (used) by operating activities</b>	<u>\$ 511,388</u>	<u>\$ (8,705)</u>	<u>\$ 21,585</u>	<u>\$ 524,268</u>

**Town of Silt**  
**Notes to the Financial Statements**  
**December 31, 2016**

---

**Note 1 - Summary of Significant Accounting Policies**

The financial statements of the Town of Silt, Colorado (the Town) have been prepared in conformity with accounting principles generally accepted in the United States of America (GAAP) as applied to government units. The Governmental Accounting Standards Board (GASB) is the accepted standard-setting body for establishing governmental accounting and financial reporting principles.

**A. Financial Reporting Entity**

The Town is a home rule municipality with a mayor and council form of government that are elected by the voters. As required by accounting principles generally accepted in the United States of America, these financial statements present the Town of Silt (the primary government). The Town has no oversight responsibility for any other governmental entity since no other entities are considered to be controlled by or dependent on the Town. Control or dependence is determined on the basis of budget adoption, taxing authority, funding, and appointment of the respective governing body.

**B. Government-wide Financial Statements**

The government-wide financial statements (i.e., the statement of net position and the statement of changes in net position) report information on all of the activities of the Town. For the most part, the effect of inter-fund activity has been removed from these statements. Governmental activities, which normally are supported by taxes, charges for services and intergovernmental revenues, are reported separately from business-type activities, which rely to a significant extent on user charges for support.

The statement of activities demonstrates the degree to which the direct expenses of a given function or segment is offset by program revenues. Direct expenses are those that are clearly identifiable with a specific function or segment. Program revenues include 1) charges to those who purchase, use, or directly benefit from goods, services, or privileges provided by a given function or segment, and 2) grants and contributions that are restricted to meeting the operational or capital requirements of a particular function or segment. Taxes and other items not properly included among program revenues are reported instead as general revenues.

**C. Fund Financial Statements**

The accounts of the Town are organized on the basis of funds and account groups, each of which is considered a separate accounting entity. The operations of each fund are accounted for with a separate set of self-balancing accounts that comprise its assets, liabilities, fund equity, revenues, and expenditures, or expenses, as appropriate. Government resources are allocated to and accounted for in individual funds based upon the purposes for which they are to be spent and the means by which spending activities are controlled.

All governmental funds are accounted for on a flow of current financial resources basis. Balance sheets for these funds generally include only current assets and current liabilities. Reported fund balances are considered a measure of available, spendable resources. Operating statements for these funds present a summary of available, spendable resources and expenditures for the period.

**Town of Silt**  
**Notes to the Financial Statements**  
**December 31, 2016**

---

**Note 1 - Summary of Significant Accounting Policies (continued)**

**C. Fund Financial Statements (continued)**

All governmental funds are accounted for on a flow of current financial resources basis. Balance sheets for these funds generally include only current assets and current liabilities. Reported fund balances are considered a measure of available, spendable resources. Operating statements for these funds present a summary of available, spendable resources and expenditures for the period.

Separate financial statements are provided for governmental funds and proprietary funds. Major individual governmental funds and major individual enterprise funds are reported as separate columns in the fund financial statements.

The Town reports the following major governmental funds:

- The General Fund is the Town's primary operating fund. It accounts for all financial resources of the Town, except those required to be accounted for in another fund.
- The Park Impact Fee Fund, which accounts for the collection of park fees to be used to improve the local parks. The major revenue sources are fees and grants. Expenditures include park maintenance and capital outlay.

Enterprise Funds account for operations that are financed and operated in a manner similar to private business enterprises, where the intent is that the costs of providing goods or services to the general public on a continuing basis be financed or recovered primarily through user charges. Enterprise funds are considered major funds because of community interests in the activities and sources of funding supporting these operations.

Enterprise funds distinguish operating revenues and expenses from nonoperating items. Operating revenues and expenses generally result from providing services and producing and delivering goods in connection with an enterprise fund's principal ongoing operations. The principal operating revenues of the Town are charges for water, sewer, and irrigation fees, and rental income. Operating expenses for the enterprise funds include purchased services, utilities, repairs and maintenance, supplies, insurance and depreciation cost. All revenues and expenses not meeting this definition are reported as nonoperating revenues and expenses.

The Town reports the following major enterprise fund business-type activities:

- Water/Wastewater, Irrigation and Silt Housing Authority Funds, which account for all operations of the Town's water and sewer, irrigation and housing authority services. They are primarily financed by user charges.

**Town of Silt**  
**Notes to the Financial Statements**  
**December 31, 2016**

---

**Note 1 - Summary of Significant Accounting Policies (continued)**

**D. Measurement Focus and Basis of Accounting**

The government-wide financial statements are reported using the economic resources measurement focus and the accrual basis of accounting, as are the enterprise fund financial statements. Revenues are recorded when earned and expenses are recorded when a liability is incurred, regardless of the timing of related cash flows. Property taxes are recognized as revenues in the year for which they are levied. Grants and similar items are recognized as revenue as soon as all eligibility requirements imposed by the provider have been met.

The modified accrual basis of accounting is used by all governmental funds. Under the modified accrual basis of accounting, revenues are recognized when susceptible to accrual (i.e., when they become both measurable and available). "Measurable" means the amount of the transaction can be determined and "available" means collectible within the current period or soon enough thereafter to be used to pay liabilities of the current period. Expenditures are recorded when the related fund liability is incurred. Exceptions to this general rule include principal and interest on general long-term debt which is recognized when due, and compensated absences which are recognized when the obligations are expected to be liquidated with expendable available resources.

Those revenues susceptible to accrual are interest revenue and charges for services. Entitlement revenues are not susceptible to accrual because generally, they are not measurable until received. Grant revenues are recognized as they are earned.

The accrual basis of accounting is utilized by enterprise funds. Under this method, revenues are recorded when earned and expenses are recorded at the time liabilities are incurred.

**E. Cash and Cash Equivalents**

For the purposes of the statement of cash flows of the enterprise funds, cash and cash equivalents consist of operating and restricted cash and highly liquid securities with an initial maturity of three months or less.

**F. Investments**

Money market funds are stated at cost, which is equal to fair market value.

**G. Use of Estimates**

The preparation of financial statements in conformity with accounting principles generally accepted in the United States of America requires management to make estimates and assumptions that affect the reported amounts of assets and liabilities and disclosure of contingent assets and liabilities at the date of the financial statements and reported amounts of revenues and expenses during the reporting period. Actual results could differ from those estimates.

**H. Property Taxes**

Property taxes for the current year are levied and attached as a lien on property the following January 1. They are payable in full by April 30 or in two equal installments due February 28 and June 15. Property taxes levied in the current year and collected in the following year are reported as a receivable at December 31. However, since the taxes are not available to pay current liabilities, the receivable is recorded as deferred inflow of resources in the governmental and enterprise funds.

**Town of Silt**  
**Notes to the Financial Statements**  
**December 31, 2016**

---

**Note 1 - Summary of Significant Accounting Policies (continued)**

**I. Capital Assets**

Capital assets, which include property, equipment and infrastructure assets, are reported in the applicable governmental or business-type activities columns in the government-wide financial statements. Capitalized assets are defined by the Town as assets that have a useful life of one or more years, and for which the initial, individual value equals or exceeds \$ 5,000.

All purchased assets are valued at cost where historical records are available and at an estimated historical cost where no historical records exist. Donated assets are valued at their estimated fair market value on the date received. The cost of normal maintenance and repairs that does not add to the value of an asset or materially extend asset life is not capitalized.

Depreciation on all assets is provided on the straight-line basis over the following estimated useful lives:

<u>Asset Class</u>	<u>Useful Life</u>
Buildings	40 years
Utility Plant and System	40 years
Distribution System	5-40 years
Machinery and Equipment	5-20 years
Infrastructure	10-20 years

Public domain assets consisting of roads, bridges, curbs and gutters, streets and sidewalks, drainage systems and lighting systems are examples of infrastructure assets. Infrastructure assets are distinguished from other capitalized assets as their useful life often extends beyond most other capital assets and are stationary in nature. General infrastructure assets are those associated with or arising from governmental activities.

Under GASB 34 the town is not required to retroactively report on infrastructure assets before June 30, 2004. Therefore, infrastructure assets before that date are not shown on the financial statements.

**J. Long-Term Liabilities**

In the government-wide financial statements, and enterprise fund types in the fund financial statements, long-term debt and other long-term obligations are reported as liabilities in the applicable government activities, business-type activities, or enterprise fund type statement of net position. Bond issuance costs, as well as applicable bond premium and discounts, are deferred and amortized over the term of the related debt using the straight-line method of amortization.

In the fund financial statements, governmental fund types recognize bond premiums and discounts, as well as bond issuance costs, during the current period. The face amount of debt issued is reported as other financing sources. Premiums received on debt issuances are reported as other financing sources while discounts on debt issuances are reported as other financing uses. Issuance costs, whether or not withheld from the actual debt proceeds received, are reported as expenditures.

**Town of Silt**  
**Notes to the Financial Statements**  
**December 31, 2016**

---

**Note 1 - Summary of Significant Accounting Policies (continued)**

**K. Compensated Absences**

Vacation shall begin accruing at the end of the employee's first six months of continuous employment. During the first through fourth year of continuous employment, excluding the first six months, full-time employees, including law enforcement personnel, shall accrue vacation time at a rate of 3.076 hours per pay period, equal to 80 hours per year. During the fifth through ninth year of continuous employment, vacation time shall accrue at a rate of 4.615 hours per pay period, equal to 120 hours per year. After ten years of continuous employment, vacation shall accrue at a rate of 6.153 hours per pay period, equal to 160 hours per year. Full-time employees and police officers shall accrue paid sick leave at a rate of 3.692 hours per pay period, equal to 96 hours per year, commencing after the first two weeks of employment. Sick leave accumulates at eight hours per month. The Town will pay 20% of accrued sick leave, up to a maximum of 80 hours, as a benefit upon termination after a minimum of two years of employment.

**L. Net Position**

Net position represents the difference between assets and liabilities. Net position invested in capital assets, net of related debt consists of capital assets, net of accumulated depreciation, reduced by the outstanding balances of any borrowing used for the acquisition or construction of improvements on those assets. Net position is reported as restricted when there are limitations imposed on their use either through the enabling legislation adopted by the Town or through external restrictions imposed by creditors, grantors, laws or regulations of other governments.

**M. Interfund Transactions**

Interfund receivables and payables arise from interfund transactions and are recorded by all funds affected in the period in which transactions are executed. At year end, outstanding balances between funds are reported as "due to/from other funds." Nonrecurring or nonroutine permanent transfers of equity are reported as residual equity transfers. All other interfund transfers are reported as operating transfers. Any residual balances outstanding between the governmental activities and business-type activities are reported in the government-wide financial statements as "internal balances."

**N. Encumbrances**

The Town does not use an encumbrance system for budgetary control.

**O. Accounts Receivable**

The Town considers accounts receivable for water and sewer to be fully collectible because the Town can place liens on the individual properties; accordingly, no allowance for doubtful accounts is required. If amounts become uncollectible, they will be charged to operations when that determination is made.

**Town of Silt**  
**Notes to the Financial Statements**  
**December 31, 2016**

---

**Note 1 - Summary of Significant Accounting Policies (continued)**

**P. Fund Equity**

Beginning with fiscal year 2011, the District implemented GASB Statement 54 "Fund Balance Reporting and Governmental Fund Type Definitions". This Statement provides more clearly defined fund balance categories to make the nature and extent of the constraints placed on a government's fund balance more transparent. The following classifications describe the relative strength of the spending constraints placed on the purposes for which resources can be used:

- Non-spendable fund balance amounts that are not in spendable form (such as inventory) or are required to be maintained intact;
- Restricted fund balance-amounts constrained to specific purposes by their providers (such as grantors, bondholders, and higher levels of government), through constitutional provisions or by enabling legislation;
- Committed fund balance-amounts constrained to specific purposes by a government itself, using its highest level of decision-making authority; to be reported as committed, amounts cannot be used for any other purpose unless the government takes the same highest level action to remove or change the constraint;
- Assigned fund balance-amounts a government intends to use for a specific purpose; intent can be expressed by the governing body or by an official or body to which the governing body delegates the authority;
- Unassigned fund balance-amounts that are available for any purpose; positive amounts are reported only in the general fund.

When expenditures are incurred for purposes for which both restricted and unrestricted net position are available, the Town considers restricted funds to have been spent first. When expenditures are incurred for which committed, assigned, or unassigned fund balances are available, the Town considers amounts to have been spent first out of committed funds, then assigned funds, and finally unassigned funds, as needed, unless the Town Council has provided otherwise in its commitment or assignment actions.

**Note 2 - Reconciliation of Government-wide and Fund Financial Statements**

The governmental funds balance sheet includes reconciliation between fund balances total governmental funds and net position - governmental activities as reported in the government-wide statement of net position. Additionally, the governmental fund statement of revenues, expenditures, and changes in fund balances includes reconciliation between net change in fund balances - total governmental funds and changes in net position of governmental activities as reported in the government-wide statement of activities. The enterprise fund statement of net position and statement of revenues, expenses and changes in net position also includes reconciliation to the government-wide statement of net position and activities.

These reconciliations detail items that require adjustment to convert from the current resources measurement and modified accrual basis for governmental fund statements to the economic resources measurement and full accrual basis used for government-wide statements. However, certain items having no effect on measurement and basis of accounting were eliminated from the governmental fund statements during the consolidation of governmental activities.

**Note 3 - Tax, Spending and Debt Limitations**

Colorado voters passed an amendment to the State Constitution, Article X, Section 20, which has several limitations, including revenue raising, spending abilities, and other specific requirements of state and local governments, excluding "enterprises."

**Town of Silt**  
**Notes to the Financial Statements**  
**December 31, 2016**

---

**Note 3 - Tax, Spending and Debt Limitations** (continued)

The Town's voters on November 1996, approved a ballot measure to permit the Town to collect, retain and expend all revenues and other funds collected in 1996 and each subsequent year thereafter, for capital projects and other municipal services without limiting in any year the amount of the other revenues that may be collected and expended by the Town of Silt in excess of the limits of Article X, Section 20 of the Colorado Constitution. This measure, however, did not remove limits on property taxes.

The Amendment is complex and subject to judicial interpretation. The Town believes it is in compliance with the requirements of the amendment.

The Amendment requires that an emergency reserve be maintained at three percent of fiscal year spending. A portion of the General Fund's fund balance is classified as restricted for emergencies as required by the Amendment.

**Note 4 - Budgets**

The Town adheres to the following procedures in establishing budgetary data reflected in the financial statements:

- A. By September of each year, the administrator gives public notice of the budget calendar for the next fiscal year. The administrator asks that all Town departments, boards, commissions or citizens submit within thirty days from the notice, any request for funds under the budget being prepared. The administrator then prepares a proposed budget for the ensuing fiscal year and submits it to the Council no later than forty-five days prior to any date required by state law for the certification to the County of the tax levy.
- B. The budget provides a complete financial plan of all Town funds and activities for the ensuing fiscal year indicating anticipated revenues, proposed operating and capital expenditures, a provision for contingencies, and anticipated net surplus or deficit for the ensuing fiscal year.
- C. A public hearing on the proposed budget is held by the Council in early December.
- D. The Council adopts the budget by resolution on or before the final day established by law for the certification of the ensuing year's tax levy to the County. Adoption of the budget by the Council shall constitute appropriations of the amounts specified therein as expenditures from the funds indicated and shall constitute a levy of the property tax therein proposed.
- E. If during the fiscal year the administrator determines that there are expenses in excess of those estimated in the budget, the Council by resolution may make supplemental appropriations for the year up to the amount of such excess. To meet an emergency affecting public property, health, peace or safety, the Council may make emergency appropriations. If at any time during the fiscal year it appears probable to the administrator that the revenues available will be insufficient to meet the amount appropriated, the administrator reports to the Council, indicating the estimated amount of deficit, any remedial action already taken, and a recommendation as to any other steps to be taken. Any time during the fiscal year the administrator may transfer part or all of any unencumbered appropriation balance within a department.
- F. Budget appropriations lapse at the end of each year.

**Town of Silt**  
**Notes to the Financial Statements**  
**December 31, 2016**

---

**Note 4 - Budgets (continued)**

- G. Expenditures may not exceed appropriations at the fund level. Budget amounts included in the financial statements are based on the final amended budget. There was one revision made to the original budgeted expenditures for the year:
- H. Budgets for governmental funds are adopted on a basis consistent with accounting principles generally accepted in the United States of America (GAAP), except for long-term receivables and advances and capital lease financing which are budgeted when liquidated rather than when the receivable/liability is incurred. Budgets for enterprise funds are adopted on a basis consistent with the spending measurement focus of the governmental funds.
- I. Budget for the Enterprise Funds are adopted on a basis consistent with the Governmental Funds.

**Note 5 - Deposits and Investments**

The Colorado Public Deposit Protection Act (PDPA) requires that all units of local governments deposit cash in eligible public depositories; eligibility is determined by state regulators. Amounts on deposit in excess of federal insurance levels must be collateralized. The eligible collateral is determined by the PDPA. PDPA allows the institution to create a single collateral pool for all public funds. The pool is to be maintained by another institution or held in trust for all the uninsured public deposits as a group. The market value of the collateral must be at least equal to the aggregate uninsured deposits. Collateral in the pool is considered to be equal to depository insurance pursuant to definitions listed in GASB Statement No. 40. At December 31, 2016, the bank balance of the Town's deposits was \$ 3,728,553 of which \$ 250,000 was covered by federal depository insurance and \$ 3,478,533 was collateralized under PDPA.

Colorado statutes specify investment instruments meeting defined rating and risk criteria in which local government entities may invest. Authorized investments include obligations of the United States and certain U.S. government agency securities; certain international agency securities; general obligation and revenue bonds of U.S. local government entities; bankers' acceptances of certain banks; commercial paper; local government investment pools; written repurchase agreements collateralized by certain authorized securities; certain money market funds; and, guaranteed investment contracts. The Town has no formal investment policy. At December 31, 2016 the Town's investments included funds held in government Colotrust.

The Town had invested \$ 904,794 in the Colorado Government Liquid Asset Trust (COLOTRUST), an investment vehicle established for local government entities in Colorado to pool surplus funds. COLOTRUST operates similarly to a money market fund and each share is equal in value to \$1.00. Investments of COLOTRUST consist of U.S. Treasury bills, notes and note strips and repurchase agreements collateralized by U.S. Treasury securities.

**Town of Silt**  
**Notes to the Financial Statements**  
**December 31, 2016**

---

**Note 5 - Deposits and Investments (continued)**

A designated custodial bank provides safekeeping and depository services to COLOTRUST in connection with the direct investment and withdrawal functions of COLOTRUST. Substantially all securities owned by COLOTRUST are held by the Federal Reserve Bank in the account maintained for the custodial bank. The custodian's internal records identify the investments owned by COLOTRUST. These pools are not required to and are not registered with the SEC. COLOTRUST's funds are rated AAAM by Standard and Poor's, Fitch's and Moody's rating services.

The composition of all cash and cash investments held by the Town at December 31, 2016 is as follows:

Cash on hand	\$ 1,875
Cash in bank	3,665,900
Colostrust	<u>904,794</u>
Total cash and investments	<u>\$ 4,572,569</u>

**Note 6 - Interfund Transactions**

Interfund receivable and payable balances as of December 31, 2016 are as follows:

<u>Receivable Fund</u>	<u>Payable Fund</u>	<u>Amount</u>
Water/Wastewater	Economic Development	\$ 141,823
Water/Wastewater	Irrigation	<u>19,918</u>
		<u>\$ 161,741</u>

The outstanding balance between funds result mainly from the time lag between the date of payments between funds are made and borrowing from the pooled cash account.

The following are the interfund transfers that occurred in 2016:

Funds	<u>Transfers</u>	
	<u>In</u>	<u>Out</u>
Water/Wastewater Fund	\$	\$ 45,073
Irrigation Fund	45,073	
Totals	<u>\$ 45,073</u>	<u>\$ 45,073</u>

**Town of Silt**  
**Notes to the Financial Statements**  
**December 31, 2016**

**Note 7 - Long-Term Liabilities**

**Schedule of Long-Term Debt**

Balance January 1, 2016	Additions	Reductions	Balance December 31, 2016	Due within one year
\$ 50,384	\$ -	\$ (36,639)	\$ 13,745	\$ 4,414
<u>\$ 50,384</u>	<u>\$ -</u>	<u>\$ (36,639)</u>	<u>\$ 13,745</u>	<u>\$ 4,414</u>
\$ 4,475,000	\$ -	\$ (300,000)	\$ 4,175,000	\$ 300,000
29,823	-	(9,644)	20,179	9,938
36,000	-	(8,510)	\$ 27,490	8,828
<u>\$ 4,540,823</u>	<u>\$ -</u>	<u>\$ (318,154)</u>	<u>\$ 4,222,669</u>	<u>\$ 318,766</u>

**A. Bonds payable-Series 2011**

The Town issued Water and Wastewater Revenue Refunding Bonds in 2011 to payoff the 2001 Wastewater Revenue Bonds and the U.S. Bank Loan. The bonds are due in semi-annual installments through 2026 with interest varying from 2.25% to 4.5%.

Bonds and interest payments are payable only from income derived by the Town from operation of the wastewater system. Principal and interest requirements for this bond issue are as follows:

	Principal	Interest	Totals
2017	\$ 300,000	\$ 164,669	\$ 464,669
2018	315,000	155,669	470,669
2019	325,000	145,037	470,037
2020	335,000	133,663	468,663
2021	350,000	121,100	471,100
2022 to 2026	2,550,000	385,300	2,935,300
Total	<u>\$ 4,175,000</u>	<u>\$ 1,105,438</u>	<u>\$ 5,280,438</u>

**Town of Silt**  
**Notes to the Financial Statements**  
**December 31, 2016**

---

**Note 7 - Long-Term Liabilities (continued)**

**B. Contract payable:**

The town entered into contract with the Bureau of Reclamation to purchase 83 acre-feet of municipal industrial water. Payments are due in annual installments through 2018 with interest of 3.05%

	<u>Principal</u>	<u>Interest</u>	<u>Totals</u>
2017	\$ 9,938	\$ 615	\$ 10,553
2018	10,241	312	10,553
Total	<u>\$ 20,179</u>	<u>\$ 927</u>	<u>\$ 21,106</u>

**C. Capital Leases:**

The Town entered into a capital lease to be used for a purchase of excavator. Payments are due in yearly installments through 2019 with interest at 3.75%.

Principal and interest payments are payable only from income derived by the Town's General Fund, Irrigation and Water Funds. Principal and interest requirements for this capital lease is as follows:

	<u>Principal</u>	<u>Interest</u>	<u>Totals</u>
2017	\$ 13,242	\$ 1,546	\$ 14,788
2018	13,739	1,049	14,788
2019	14,254	534	14,788
Total	<u>\$ 41,235</u>	<u>\$ 3,129</u>	<u>\$ 44,364</u>

**Note 8 - Contingent liabilities**

**Risk management**

The Town is exposed to various risks of loss related to torts; theft of, damages to, and destruction of assets; errors and omissions; injuries to employees; and natural disasters. The Town pays an annual premium to CIRSA Property/Casualty and Workers' Compensation for its general liability and workmen's compensation insurance coverage. The agreement with CIRSA will be self-sustaining through member premiums. CIRSA rate-setting policies are established by the Board of Directors, in consultation with independent actuaries. The Board of Directors may credit member municipalities' future contributions in the event of a surplus. Although it has never occurred, CIRSA member municipalities are subject to a supplemental assessment in the event of a deficiency.

There were no settlements exceeding insurance coverage over the last three years.

**Town of Silt**  
**Notes to the Financial Statements**  
**December 31, 2016**

---

**Note 9 - Retirement Plans**

Defined Contribution Plan

The Town has a defined contribution plan for its employees which is administered by Colorado County Officials and Employees Retirement Association (CCOERA). In a defined contribution plan, benefits depend solely on amounts contributed to the plan, plus investment earnings. Employees are eligible to participate year from the date of employment. Both the employees and the Town make a basic contribution of 4% of the employee's salary. Employees may make additional voluntary contributions not to exceed 10% of compensations. Participants vest in employer contributions and in earnings, losses and changes in fair market value of Plan assets at a rate of 20% per year. Any nonvested Town contributions forfeited by an employee who leaves the Town's employment are remitted to the Town.

The Town's total payroll in 2016 was \$ 1,389,533. The total payroll covered by the plan was \$837,958. A contribution of \$ 80,490 was made to the plan in 2016. This contribution consisted of the Town's contribution of \$ 33,152 and the employee's contributions of \$ 47,338.

Defined Benefit Plan- SWDB

The Town's police officers participate in the Statewide Defined Benefit Plan (SWDB), which is a cost-sharing multiple-employer defined benefit pension plan. The Plan is administered by the Fire & Police Pension Association of Colorado (FPPA). FPPA issues a publicly available comprehensive annual financial report that can be obtained on FPPA's website at <http://www.fppaco.org>.

A member is eligible for a normal retirement pension once the member has completed twenty-five years of credited service and has attained the age of 55.

The annual normal retirement benefit is 2 percent of the average of the member's highest three years' base salary for each year of credited service up to ten years, plus 2.5 percent for each year of service thereafter. The benefit earned prior to January 1, 2007 for members of affiliated Social Security employers will be reduced by the amount of Social Security income payable to the member annually. Effective January 1, 2007, members currently covered under Social Security will receive half the benefit when compared to the Statewide Defined Benefit Plan.

Benefits paid to retired members are evaluated and may be re-determined every October 1. The amount of any increase is based on the Board's discretion and can range from 0 to the higher of 3 percent or the Consumer Price Index.

A member is eligible for an early retirement at age 50 or after 30 years of service. The early retirement benefit equals the normal retirement benefit reduced on an actuarially equivalent basis. Upon termination, an employee may elect to have member contributions, along with 5 percent as interest, returned as a lump sum distribution. Alternatively, a member with at least five years of accredited service may leave contributions with the Plan and remain eligible for a retirement pension at age 55 equal to 2 percent of the member's average highest three years' base salary for each year of credited service up to ten years, plus 2.5 percent for each year of service thereafter.

The Plan sets contribution rates at a level that enables all benefits to be fully funded at the retirement date of all members. Contribution rates for the SWDB plan are set by state statute. Employer contribution rates can only be amended by state statute. Member contribution rates can be amended by state statute or election of the membership.

**Town of Silt**  
**Notes to the Financial Statements**  
**December 31, 2016**

**Note 9 - Retirement Plans (continued)**

Defined Benefit Plan- SWDB (continued)

Members of the SWDB plan and their employers are contributing at the rate of 8.5 percent and 8 percent, respectively, of base salary for a total contribution rate of 16.5 percent through 2015. In 2014, the members elected to increase the member contribution rate to the SWDB plan beginning in 2015. Member contribution rates will increase 0.5 percent annually through 2022 to a total of 12 percent of base salary. Employer contributions will remain at 8 percent resulting in a combined contribution rate of 20 percent in 2022.

Contributions from members and employers of departments re-entering the system are established by resolution and approved by the FPPA Board of Directors. The re-entry group has a combined contribution rate of 20.5 percent of base salary through 2015. It is a local decision as to whether the member or employer pays the additional 4 percent contribution. Per the 2014 member election, the re-entry group will also have their required member contribution rate increase 0.5 percent annually beginning in 2015 through 2022 for a total combined member and employer contribution rate of 24 percent in 2022.

The contribution rate for members and employers of affiliated social security employers is 4.25 percent and 4 percent, respectively, of base salary for a total contribution rate of 8.25 percent through 2015. Per the 2014 member election, members of the affiliate social security group will have their required contribution rate increase 0.25 percent annually beginning in 2015 through 2022 to a total of 6 percent of base salary. Employer contributions will remain at 4 percent resulting in a combined contribution rate of 10 percent in 2022.

**Pension Liabilities/ (Asset), Pension Expense, and Deferred Outflows of Resources and Deferred Inflows of Resources Related to Pensions**

At December 31, 2015, the Entity reported a net pension liability/ (asset) of \$(1,316). The net pension liability/ (asset) was measured as of December 31, 2015, and the total pension liability used to calculate the net pension liability/ (asset) was determined by an actuarial valuation as of January 1, 2015.

At December 31, 2015, the Entity reported deferred outflows of resources and deferred inflows of resources related to pensions from the following sources:

	Deferred Outflows of Resources	Deferred Inflows of Resources
Difference between expected and actual experience	\$ 10,643	\$ 1,554
Changes in Assumptions	20,670	-
Net difference between projected and actual earnings on pension plan investments	66,974	-
Contributions subsequent to the measurement date	28,950	-
Total	<u>\$127,237</u>	<u>\$ 1,554</u>

**Town of Silt**  
**Notes to the Financial Statements**  
**December 31, 2016**

---

**Note 9 - Retirement Plans (continued)**

Defined Benefit Plan- SWDB (continued)

Other amounts reported as deferred outflows of resources and deferred inflows of resources related to pensions will be recognized in pension expense as follows:

Year ended December 31:	
2016	\$20,377
2017	\$20,377
2018	\$20,377
2019	\$18,717
2020	\$ 3,219
Thereafter	\$13,666

The January 1, 2015 actuarial valuation was used to determine the Actuarially Determined Contribution for the fiscal year ending December 31, 2015. The valuation used the following actuarial assumption and other inputs:

**Methods and Assumptions Used to Determine Contribution Rates:**

Actuarial Cost Method	Entry Age Normal
Amortization Method	Level % of payroll, Open
Amortization Period	30 years
Asset Valuation Method	5-Year smoothed fair value
Long-term Investment rate of return*	7.5%
Projected Salary Increases	4.0%-14.0%
Cola adjustment	0.0%
*Includes Inflation At	3.0%

The RP-2000 Combined Mortality Table with Blue Collar Adjustment, projected with Scale AA, 40 percent multiplier for off-duty mortality is used in the valuation for off-duty mortality of active members. On-duty related mortality is assumed to be 0.00020 per year for all members. The RP-2000 Combined Mortality Table with Blue Collar Adjustment, projected with Scale AA is used in the projection of post-retirement benefits.

The long-term expected rate of return on pension plan investments was determined using a building-block method in which best-estimate ranges of expected future real rates of return (expected returns, net of pension plan investment expense and inflation) are developed for each major asset class. These ranges are combined to produce the long-term expected rate of return by weighing the expected future real rates of return by the target asset allocation percentage and by adding expected inflation. Best estimates of arithmetic real rates of return for each major asset class included in the Fund's target asset allocation as of December 31, 2015 are summarized in the following table:

**Town of Silt**  
**Notes to the Financial Statements**  
**December 31, 2016**

**Note 9 - Retirement Plans (continued)**

Defined Benefit Plan- SWDB (continued)

Asset Class	Target Allocation	Long-Term Expected Rate of Return
Global Equity	37.0%	6.5%
Equity Long/Short	10.0%	4.7%
Illiquid Alternatives	20.0%	8.0%
Fixed Income	16.0%	1.5%
Absolute Return	11.0%	4.1%
Managed Futures	4.0%	3.0%
Cash	2.0%	0.0%
<b>Total</b>	<b>100.00%</b>	

In setting the long-term expected rate of return, projections employed to model future returns provide a range of expected long-term returns that, including expected inflation, ultimately support a long-term expected rate of return assumption of 7.50%.

Discount rate: Projected benefit payments are required to be discounted to their actuarial present values using a Single Discount Rate that reflects (1) a long-term expected rate of return on pension plan investments (to the extent that the plan's fiduciary net position is projected to be sufficient to pay benefits) and (2) tax-exempt municipal bond rate based on an index of 20-year general obligation bonds with an average AA credit rating as of the measurement date (to the extent that the plan's projected fiduciary net position is not sufficient to pay benefits).

For the purpose of this valuation, the expected rate of return on pension plan investments is 7.50%; the municipal bond rate is 3.57% (based on the weekly rate closest to but not later than the measurement date of the "state & local bonds" rate from Federal Reserve statistical release (H.15)); and the resulting Single Discount Rate is 7.50%.

Regarding the sensitivity of the net pension liability to changes in the Single Discount Rate, the following presents the plan's net pension liability, calculated using a Single Discount Rate of 7.50%, as well as what the plan's net pension liability would be if it were calculated using a Single Discount Rate that is one percent lower or one percent higher:

1% Decrease	Single Discount Rate Assumption	1% Increase
6.50%	7.50%	8.50%
\$184,343	\$(1,316)	\$(155,314)

**Town of Silt**  
**Notes to the Financial Statements**  
**December 31, 2016**

**Note 10 - Capital Assets**

	Balance January 1, 2016	Additions	Dispositions	Balance December 31, 2016
Governmental Activities				
Capital assets not being depreciated				
Land	\$ 1,786,219	\$ -	\$ -	\$ 1,786,219
	<u>1,786,219</u>	<u>-</u>	<u>-</u>	<u>1,786,219</u>
Capital assets being depreciated				
Buildings	842,164	-	-	842,164
Improvements/infrastructure	5,714,854	1,075,798	-	6,790,652
Machinery and equipment	687,097	12,617	-	699,714
	<u>7,244,115</u>	<u>1,088,415</u>	<u>-</u>	<u>8,332,530</u>
Less accumulated depreciation				
Buildings	(641,222)	(39,308)	-	(680,530)
Improvements/infrastructure	(3,119,656)	(226,823)	-	(3,346,479)
Machinery and equipment	(376,058)	(65,313)	-	(441,371)
	<u>(4,136,936)</u>	<u>(331,444)</u>	<u>-</u>	<u>(4,468,380)</u>
Capital asset being depreciated, net	<u>3,107,179</u>	<u>756,971</u>	<u>-</u>	<u>3,864,150</u>
Total Capital Assets	<u>\$ 4,893,398</u>	<u>\$ 756,971</u>	<u>\$ -</u>	<u>\$ 5,650,369</u>

	Balance January 1, 2016	Additions	Dispositions	Balance December 31, 2016
Business - Type Activities				
Capital assets not being depreciated				
Land	\$ 436,072	\$ -	\$ -	\$ 436,072
Capital assets being depreciated				
Treatment plants	7,832,881	-	-	7,832,881
Distribution system	3,379,465	313,215	-	3,692,680
Irrigation system	1,191,175	-	-	1,191,175
Buildings	1,032,385	-	-	1,032,385
Machinery and equipment	227,029	-	-	227,029
Less accumulated depreciation	(4,689,296)	(399,430)	-	(5,088,726)
Capital assets being depreciated, net	<u>8,973,639</u>	<u>(86,215)</u>	<u>-</u>	<u>8,887,424</u>
Total Business-Type Activities Capital Assets	<u>\$ 9,409,711</u>	<u>\$ (86,215)</u>	<u>\$ -</u>	<u>\$ 9,323,496</u>

**Town of Silt**  
**Notes to the Financial Statements**  
**December 31, 2016**

---

**Note 10 - Capital Assets (continued)**

Depreciation was charged to governmental activity functions/programs as follows:

General government	\$ 21,592
Public safety	41,192
Public works	221,188
Parks and recreation	<u>47,472</u>
Total	<u>\$ 331,444</u>

Depreciation charged to the Enterprise Funds are as follows:

Water/Wastewater Fund	\$ 330,524
Irrigation Fund	38,970
Silt Housing Authority	<u>29,936</u>
Total	<u>\$ 399,430</u>

**TOWN OF SILT, COLORADO**  
**Schedule of Change in Net Pension Asset**  
**For the Year Ended December 31, 2016**

---

Measurement Date:		December 31, 2015
Employer portion of NPA-December 31, 2014		0.00076257 %
Employer portion of NPA-December 31, 2015		0.00074648 %
Employer proportionate share of NPA	\$	1,316
Employer covered payroll	\$	374,332
Employer proportionate share of NPA as a percentage of covered payroll		0%

**TOWN OF SILT, COLORADO**  
**Schedule of Contributions to Pension Plan**  
**For the Year Ended December 31, 2016**

---

Required Employer Contributions	December 31, 2014	\$	27,434
Required Employer Contributions	December 31, 2015	\$	27,737
Required Employer Contributions	December 31, 2015	\$	27,737
Employer contributions recognized by plan	December 31, 2016	\$	28,950
Difference		\$	-
Employer covered payroll		\$	374,332
Contributions as a percentage of employer covered payroll			8%

**TOWN OF SILT, COLORADO**  
**Schedule of Revenues, Expenditures and Changes in Fund Balance-Budget and Actual**  
**General Fund**  
**For the Year Ended December 31, 2016**

	<b>Budgeted Amounts</b>		<b>Actual</b>	<b>Variance</b>
	<b>Original</b>	<b>Final</b>		<b>Favorable (Unfavorable)</b>
<b>Revenues</b>				
Taxes	\$ 1,256,680	\$ 1,279,680	\$ 1,356,220	\$ 76,540
Intergovernmental	451,890	454,890	300,936	(153,954)
Licenses/Permits	32,800	47,800	57,966	10,166
Operating Grants and Contributions	269,225	930,225	861,472	(68,753)
Charges for services	262,625	297,625	301,483	3,858
Fines and Forfeits	25,450	25,450	22,411	(3,039)
Interest	5,600	7,600	7,830	230
Administration Fees	30,290	30,290	30,290	-
Miscellaneous	90,950	101,950	59,221	(42,729)
<b>Total revenues</b>	<u>2,425,510</u>	<u>3,175,510</u>	<u>2,997,829</u>	<u>(177,681)</u>
<b>Expenditures</b>				
General government	606,070	1,042,070	940,104	101,966
Public safety	720,784	723,784	675,173	48,611
Public works	999,971	1,106,442	1,116,435	(9,993)
Parks and Recreation	96,818	301,347	274,084	27,263
<b>Total Expenditures</b>	<u>2,423,643</u>	<u>3,173,643</u>	<u>3,005,796</u>	<u>167,847</u>
<b>Excess of Revenues over (under) Expenditures</b>	1,867	1,867	(7,967)	(9,834)
<b>Fund balance, January 1</b>	1,568,109	1,568,109	1,508,807	(59,302)
<b>Residual transfer</b>	-	-	8,256	8,256
<b>Fund balance, December 31</b>	<u>\$ 1,569,976</u>	<u>\$ 1,569,976</u>	<u>\$ 1,509,096</u>	<u>\$ (60,880)</u>

**TOWN OF SILT, COLORADO**  
**Statement of Revenues, Expenditures and Changes in Fund Balance-Budget and Actual**  
**Park Impact Fee Fund**  
**For the Year Ended December 31, 2016**

	<u>Budgeted Amounts</u>		<u>Actual</u>	<u>Variance with Final Budget Favorable (Unfavorable)</u>
	<u>Original</u>	<u>Final</u>		
<b>Revenues</b>				
Impact Fees	\$ 1,000	\$ 1,000	\$ 6,805	\$ 5,805
Interest	50	50	41	(9)
<b>Total revenues</b>	<u>1,050</u>	<u>1,050</u>	<u>6,846</u>	<u>5,796</u>
<b>Expenditures</b>				
Capital Outlay	30,000	30,000	30,000	-
<b>Total expenditures</b>	<u>30,000</u>	<u>30,000</u>	<u>30,000</u>	<u>-</u>
<b>Excess of Revenues over (under) Expenditures</b>	(28,950)	(28,950)	(23,154)	5,796
<b>Fund Balance, January 1</b>	<u>63,964</u>	<u>63,964</u>	<u>77,361</u>	<u>13,397</u>
<b>Fund Balance, December 31</b>	<u>\$ 35,014</u>	<u>\$ 35,014</u>	<u>\$ 54,207</u>	<u>\$ 19,193</u>

**TOWN OF SILT, COLORADO**  
**Statement of Revenues, Expenditures and Changes in Fund Balance-Budget and Actual**  
**Park Impact Fee Fund**  
**For the Year Ended December 31, 2016**

	<u>Budgeted Amounts</u>		<u>Actual</u>	<b>Variance with Final Budget Favorable (Unfavorable)</b>
	<u>Original</u>	<u>Final</u>		<u>(Unfavorable)</u>
<b>Revenues</b>				
Impact Fees	\$ 1,000	\$ 1,000	\$ 6,805	\$ 5,805
Interest	50	50	41	(9)
<b>Total revenues</b>	<u>1,050</u>	<u>1,050</u>	<u>6,846</u>	<u>5,796</u>
<b>Expenditures</b>				
Capital Outlay	30,000	30,000	30,000	-
<b>Total expenditures</b>	<u>30,000</u>	<u>30,000</u>	<u>30,000</u>	<u>-</u>
<b>Excess of Revenues over (under) Expenditures</b>	(28,950)	(28,950)	(23,154)	5,796
<b>Fund Balance, January 1</b>	<u>63,964</u>	<u>63,964</u>	<u>77,361</u>	<u>13,397</u>
<b>Fund Balance, December 31</b>	<u>\$ 35,014</u>	<u>\$ 35,014</u>	<u>\$ 54,207</u>	<u>\$ 19,193</u>

**TOWN OF SILT, COLORADO**  
**Combining Balance Sheet**  
**Nonmajor Governmental Funds**  
**December 31, 2016**

	<b>Conservation Trust Fund</b>	<b>Construction Fee Impact Fund</b>	<b>Victim Assistance</b>
<b>Assets</b>			
Cash and cash equivalents	\$ 83,346	\$ 20,210	\$ 59,868
Accounts receivable	-	-	-
<b>Total assets</b>	<b><u>\$ 83,346</u></b>	<b><u>\$ 20,210</u></b>	<b><u>\$ 59,868</u></b>
<b>Liabilities and Fund Balances</b>			
<b>Liabilities:</b>			
Accrued Payroll	\$ -	\$ -	\$ -
Due to Other Funds	-	-	-
<b>Total liabilities</b>	<b><u>-</u></b>	<b><u>-</u></b>	<b><u>-</u></b>
<b>Fund balances:</b>			
Unreserved:	<u>83,346</u>	<u>20,210</u>	<u>59,868</u>
Total fund balances	<u>83,346</u>	<u>20,210</u>	<u>59,868</u>
<b>Total liabilities and fund balances</b>	<b><u>\$ 83,346</u></b>	<b><u>\$ 20,210</u></b>	<b><u>\$ 59,868</u></b>

**TOWN OF SILT, COLORADO**  
**Combining Balance Sheet**  
**Nonmajor Governmental Funds**  
**December 31, 2016**

	<u>Conservation Trust Fund</u>	<u>Construction Fee Impact Fund</u>	<u>Victim Assistance</u>
<b>Assets</b>			
Cash and cash equivalents	\$ 83,346	\$ 20,210	\$ 59,868
Accounts receivable	-	-	-
<b>Total assets</b>	<u>\$ 83,346</u>	<u>\$ 20,210</u>	<u>\$ 59,868</u>
<b>Liabilities and Fund Balances</b>			
<b>Liabilities:</b>			
Accrued Payroll	\$ -	\$ -	\$ -
Due to Other Funds	-	-	-
<b>Total liabilities</b>	<u>-</u>	<u>-</u>	<u>-</u>
<b>Fund balances:</b>			
Unreserved:	83,346	20,210	59,868
Total fund balances	<u>83,346</u>	<u>20,210</u>	<u>59,868</u>
<b>Total liabilities and fund balances</b>	<u>\$ 83,346</u>	<u>\$ 20,210</u>	<u>\$ 59,868</u>

<b>Beautification Fund</b>	<b>Mountain Valley Development Fund</b>	<b>Economic Development Fund</b>	<b>Total Nonmajor Governmental Funds</b>
\$ 157,500	\$ -	\$ 1	\$ 320,925
-	-	141,823	141,823
<u>\$ 157,500</u>	<u>\$ -</u>	<u>\$ 141,824</u>	<u>\$ 462,748</u>
\$ -	\$ -	\$ -	\$ -
-	-	141,824	141,824
-	-	141,824	141,824
157,500	-	-	320,924
157,500	-	-	320,924
<u>\$ 157,500</u>	<u>\$ -</u>	<u>\$ 141,824</u>	<u>\$ 462,748</u>

**TOWN OF SILT, COLORADO**  
**Combining Statement of Revenues, Expenditures and Changes in Fund Balances**  
**Nonmajor Governmental Funds**  
**December 31, 2016**

	<b>Conservation Trust Fund</b>	<b>Construction Fee Impact Fund</b>	<b>Victim Assistance</b>
<b>REVENUES</b>			
Taxes	\$ -	\$ -	\$ -
Operating Grants and Contributions	33,593	-	-
Fines and Forfeits	-	-	5,100
Impact Fees	-	6,689	-
Interest Income	55	-	-
<b>Total revenues</b>	<u>33,648</u>	<u>6,689</u>	<u>5,100</u>
<b>EXPENDITURES</b>			
General Government	-	-	-
Public Safety	-	-	760
Capital Outlay	14,282	-	-
<b>Total expenditures</b>	<u>14,282</u>	<u>-</u>	<u>760</u>
<b>Excess revenues over (under) expenditures</b>	19,366	6,689	4,340
<b>Fund balance, January 1</b>	63,980	13,521	55,528
<b>Residual transfer</b>	<u>-</u>	<u>-</u>	<u>-</u>
<b>Fund balance, December 31</b>	<u>\$ 83,346</u>	<u>\$ 20,210</u>	<u>\$ 59,868</u>

**TOWN OF SILT, COLORADO**  
**Combining Statement of Revenues, Expenditures and Changes in Fund Balances**  
**Nonmajor Governmental Funds**  
**December 31, 2016**

---

	<b>Conservation Trust Fund</b>	<b>Construction Fee Impact Fund</b>	<b>Victim Assistance</b>
<b>REVENUES</b>			
Taxes	\$ -	\$ -	\$ -
Operating Grants and Contributions	33,593	-	-
Fines and Forfeits	-	-	5,100
Impact Fees	-	6,689	-
Interest Income	55	-	-
<b>Total revenues</b>	<u>33,648</u>	<u>6,689</u>	<u>5,100</u>
<b>EXPENDITURES</b>			
General Government	-	-	-
Public Safety	-	-	760
Capital Outlay	14,282	-	-
<b>Total expenditures</b>	<u>14,282</u>	<u>-</u>	<u>760</u>
<b>Excess revenues over (under) expenditures</b>	19,366	6,689	4,340
<b>Fund balance, January 1</b>	63,980	13,521	55,528
<b>Residual transfer</b>	-	-	-
<b>Fund balance, December 31</b>	<u>\$ 83,346</u>	<u>\$ 20,210</u>	<u>\$ 59,868</u>

<b>Beautification Fund</b>	<b>Mountain Valley Development Fund</b>	<b>Economic Development Fund</b>	<b>Total Nonmajor Governmental Funds</b>
\$ 47,200	\$ -	\$ -	\$ 47,200
-	-	16,285	49,878
-	-	-	5,100
-	-	-	6,689
27	-	-	82
<u>47,227</u>	<u>-</u>	<u>16,285</u>	<u>108,949</u>
-	732	16,285	17,017
-	-	-	760
4,589	-	-	18,871
<u>4,589</u>	<u>732</u>	<u>16,285</u>	<u>36,648</u>
42,638	(732)	-	72,301
114,862	8,988	-	256,879
-	(8,256)	-	(8,256)
<u>\$ 157,500</u>	<u>\$ -</u>	<u>\$ -</u>	<u>\$ 320,924</u>

**TOWN OF SILT, COLORADO**  
**Statement of Revenues, Expenditures and Changes in Fund Balance-Budget and Actual**  
**Conservation Trust Fund**  
**For the Year Ended December 31, 2016**

	<u>Budgeted Amounts</u>		<u>Actual</u>	<b>Variance with Final Budget Favorable (Unfavorable)</b>
	<u>Original</u>	<u>Final</u>		
<b>Revenues</b>				
Operating Grants and Contributions	\$ 28,500	\$ 28,500	\$ 33,593	\$ 5,093
Interest Income	55	55	55	-
<b>Total revenues</b>	<u>28,555</u>	<u>28,555</u>	<u>33,648</u>	<u>5,093</u>
<b>Expenditures</b>				
Capital outlay	20,000	20,000	14,282	5,718
<b>Total expenditures</b>	<u>20,000</u>	<u>20,000</u>	<u>14,282</u>	<u>5,718</u>
<b>Excess of Revenues over (under) Expenditures</b>	8,555	8,555	19,366	10,811
<b>Fund balance, January 1</b>	<u>35,158</u>	<u>35,158</u>	<u>63,980</u>	<u>28,822</u>
<b>Fund balance, December 31</b>	<u>\$ 43,713</u>	<u>\$ 43,713</u>	<u>\$ 83,346</u>	<u>\$ 39,633</u>

**TOWN OF SILT, COLORADO**  
**Schedule of Revenues, Expenditures and Changes in Fund Balance-Budget and Actual**  
**Construction Impact Fee Fund**  
**For the Year Ended December 31, 2016**

	<u>Budgeted Amounts</u>		<u>Actual</u>	<b>Variance with</b>
	<u>Original</u>	<u>Final</u>		<b>Final Budget</b>
<b>Revenues</b>				<b>Favorable</b>
				<b>(Unfavorable)</b>
Impact Fees	\$ 1,000	\$ 1,000	\$ 6,689	\$ 5,689
<b>Total revenues</b>	<u>1,000</u>	<u>1,000</u>	<u>6,689</u>	<u>5,689</u>
<b>Expenditures</b>				
Projects	-	-	-	-
<b>Total expenditures</b>	<u>-</u>	<u>-</u>	<u>-</u>	<u>-</u>
<b>Excess of revenues over</b>				
<b>(under) expenditures</b>	1,000	1,000	6,689	5,689
<b>Fund balance, January 1</b>	<u>7,832</u>	<u>7,832</u>	<u>13,521</u>	<u>5,689</u>
<b>Fund balance, December 31</b>	<u>\$ 8,832</u>	<u>\$ 8,832</u>	<u>\$ 20,210</u>	<u>\$ 11,378</u>

**TOWN OF SILT, COLORADO**  
**Schedule of Revenues, Expenditures and Changes in Fund Balance-Budget and Actual**  
**Victim Assistance Fund**  
**For the Year Ended December 31, 2016**

	<u>Budgeted Amounts</u>		<u>Actual</u>	<u>Variance with Final Budget Favorable (Unfavorable)</u>
	<u>Original</u>	<u>Final</u>		
<b>Revenues</b>				
Fines and Forfeits	\$ 5,000	\$ 5,000	\$ 5,100	\$ 100
<b>Total revenues</b>	<u>5,000</u>	<u>5,000</u>	<u>5,100</u>	<u>100</u>
<b>Expenditures</b>				
Public Safety	3,500	3,500	760	2,740
<b>Total expenditures</b>	<u>3,500</u>	<u>3,500</u>	<u>760</u>	<u>2,740</u>
<b>Excess of revenues over (under) expenditures</b>	1,500	1,500	4,340	2,840
<b>Fund balance, January 1</b>	<u>54,014</u>	<u>54,014</u>	<u>55,528</u>	<u>1,514</u>
<b>Fund balance, December 31</b>	<u>\$ 55,514</u>	<u>\$ 55,514</u>	<u>\$ 59,868</u>	<u>\$ 4,354</u>

**TOWN OF SILT, COLORADO**  
**Schedule of Revenues, Expenditures and Changes in Fund Balance-Budget and Actual**  
**Beautification Fund**  
**For the Year Ended December 31, 2016**

	<u>Budgeted Amounts</u>		<u>Actual</u>	<b>Variance with</b>
	<u>Original</u>	<u>Final</u>		<b>Final Budget</b>
<b>Revenues</b>				<b>Favorable</b>
Taxes	\$ 33,000	\$ 33,000	\$ 47,200	\$ 14,200
Interest	40	40	27	(13)
<b>Total revenues</b>	<u>33,040</u>	<u>33,040</u>	<u>47,227</u>	<u>14,187</u>
<b>Expenditures</b>				
Capital outlay	<u>30,000</u>	<u>30,000</u>	<u>4,589</u>	25,411
<b>Total expenditures</b>	<u>30,000</u>	<u>30,000</u>	<u>4,589</u>	<u>25,411</u>
<b>Excess of Revenues over</b>				
<b>(under) Expenditures</b>	3,040	3,040	42,638	39,598
<b>Fund balance, January 1</b>	<u>86,767</u>	<u>86,767</u>	<u>114,862</u>	<u>28,095</u>
<b>Fund balance, December 31</b>	<u>\$ 89,807</u>	<u>\$ 89,807</u>	<u>\$ 157,500</u>	<u>\$ 67,693</u>

**TOWN OF SILT, COLORADO**  
**Schedule of Revenues, Expenditures and Changes in Fund Balance-Budget and Actual**  
**Mountain Valley Development Fund**  
**For the Year Ended December 31, 2016**

	<u>Budgeted Amounts</u>		<u>Actual</u>	<u>Variance with Final Budget Favorable (Unfavorable)</u>
	<u>Original</u>	<u>Final</u>		
<b>Revenues</b>				
Operating Grants and Contributions	\$ -	\$ -	\$ -	\$ -
<b>Total revenues</b>	<u>-</u>	<u>-</u>	<u>-</u>	<u>-</u>
<b>Expenditures</b>				
Miscellaneous	-	-	732	(732)
<b>Total expenditures</b>	<u>-</u>	<u>-</u>	<u>732</u>	<u>(732)</u>
<b>Excess of Revenues over (under) Expenditures</b>	-	-	(732)	(732)
<b>Fund balance, January 1</b>	-	-	8,988	8,988
<b>Residual transfer</b>	<u>-</u>	<u>-</u>	<u>(8,256)</u>	<u>(8,256)</u>
<b>Fund balance, December 31</b>	<u>\$ -</u>	<u>\$ -</u>	<u>\$ -</u>	<u>\$ -</u>

**TOWN OF SILT, COLORADO**  
**Schedule of Revenues, Expenditures and Changes in Available Resources-Budget and Actual**  
**Water/Wastewater Fund**  
**For the Year Ended December 31, 2016**

	Budgeted Amounts		Actual	Variance with
	Original	Final		Final Budget
				Favorable
<b>Revenues</b>				<b>(Unfavorable)</b>
Charges for Services	\$ 1,471,100	\$ 1,495,100	\$ 1,590,482	\$ 95,382
Interest revenue	15,900	20,900	9,450	(11,450)
Tap Fees	100,000	150,000	170,411	20,411
Loan payments	20,515	20,515	20,515	-
Grants and Contributions	300,000	520,000	243,202	(276,798)
Miscellaneous	53,000	54,000	37,827	(16,173)
<b>Total revenues</b>	<u>1,960,515</u>	<u>2,260,515</u>	<u>2,071,887</u>	<u>(188,628)</u>
<b>Expenditures</b>				
Administration	486,310	486,310	478,200	8,110
Operations	649,632	724,632	642,546	82,086
Capital Outlay	300,000	525,000	313,215	211,785
Debt service				
Principal	300,000	300,000	300,000	-
Interest	172,920	172,920	172,918	2
<b>Total expenditures</b>	<u>1,908,862</u>	<u>2,208,862</u>	<u>1,906,879</u>	<u>301,983</u>
<b>Excess of Revenues over</b>				
<b>(under) Expenditures</b>	<u>51,653</u>	<u>51,653</u>	<u>165,008</u>	<u>113,355</u>
<b>Other Financing Sources (Uses)</b>				
Transfers in (out)	<u>(49,170)</u>	<u>(49,170)</u>	<u>(45,073)</u>	<u>4,097</u>
<b>Change in available resources</b>	2,483	2,483	119,935	117,452
<b>Available resources, January 1</b>	2,174,757	2,174,757	2,135,081	(39,676)
<b>Change in accrual expenses</b>	<u>-</u>	<u>-</u>	<u>(25,848)</u>	<u>(25,848)</u>
<b>Available resources, December 31</b>	<u>\$ 2,177,240</u>	<u>\$ 2,177,240</u>	<u>\$ 2,229,168</u>	<u>\$ 51,928</u>

**TOWN OF SILT, COLORADO**  
**Schedule of Revenues, Expenditures and Changes in Available Resources-Budget and Actual**  
**Irrigation Fund**  
**For the Year Ended December 31, 2016**

	<b>Budgeted Amounts</b>		<b>Actual</b>	<b>Variance with</b>
	<b>Original</b>	<b>Final</b>		<b>Final Budget</b>
<b>Revenues</b>				<b>Favorable</b>
				<b>(Unfavorable)</b>
Charges for Services	\$ 198,000	\$ 218,000	\$ 213,798	\$ (4,202)
Tap Fees	1,000	6,000	4,930	(1,070)
<b>Total revenues</b>	<u>199,000</u>	<u>224,000</u>	<u>218,728</u>	<u>(5,272)</u>
<b>Expenditures</b>				
Administration	129,220	129,220	122,661	6,559
Operations	91,405	116,405	101,446	14,959
Debt Service				
Principal	24,268	24,268	23,593	675
Interest	1,178	1,178	1,852	(674)
<b>Total expenditures</b>	<u>246,071</u>	<u>271,071</u>	<u>249,552</u>	<u>21,519</u>
<b>Excess of revenues over</b>				
<b>(under) expenditures</b>	<u>(47,071)</u>	<u>(47,071)</u>	<u>(30,824)</u>	<u>16,247</u>
<b>Other Financing Sources (Uses)</b>				
Transfers in	49,170	49,170	45,073	4,097
<b>Change in available resources</b>	2,099	2,099	14,249	12,150
<b>Available Resources, January 1</b>	557,835	557,835	554,297	(3,538)
<b>Change in accrual expenses</b>	<u>-</u>	<u>-</u>	<u>(19,917)</u>	<u>(19,917)</u>
<b>Available Resources, December 31</b>	<u>\$ 559,934</u>	<u>\$ 559,934</u>	<u>\$ 548,629</u>	<u>\$ (11,305)</u>

**TOWN OF SILT, COLORADO**  
**Schedule of Revenues, Expenditures and Changes in Available Resources-Budget and Actual**  
**Silt Housing Authority**  
**For the Year Ended December 31, 2016**

	<b>Budgeted Amounts</b>		<b>Actual</b>	<b>Variance with</b>
	<b>Original</b>	<b>Final</b>		<b>Final Budget</b>
<b>Revenues</b>				<b>Favorable</b>
Charges for Services	\$ 155,000	\$ 155,000	\$ 154,247	\$ (753)
Interest revenue	225	225	793	568
<b>Total revenues</b>	<b>155,225</b>	<b>155,225</b>	<b>155,040</b>	<b>(185)</b>
<b>Expenditures</b>				
Administration	32,122	32,122	32,528	(406)
Operations	122,945	122,945	107,088	15,857
<b>Total expenditures</b>	<b>155,067</b>	<b>155,067</b>	<b>139,616</b>	<b>15,451</b>
<b>Excess of Revenues over</b>				
<b>(under) Expenditures</b>	158	158	15,424	15,266
<b>Available resources, January 1</b>	<b>165,003</b>	<b>165,003</b>	<b>168,243</b>	<b>3,240</b>
<b>Available resources, December 31</b>	<b>\$ 165,161</b>	<b>\$ 165,161</b>	<b>\$ 183,667</b>	<b>\$ 18,506</b>

**TOWN OF SILT, COLORADO**  
**Schedule of Revenues, Expenditures and Changes in Fund Balance-Budget and Actual**  
**Economic Development Fund**  
**For the Year Ended December 31, 2016**

	<u>Budgeted Amounts</u>		<u>Actual</u>	<u>Variance with Final Budget Favorable (Unfavorable)</u>
	<u>Original</u>	<u>Final</u>		
<b>Revenues</b>				
Operating Grants and Contributions	\$ 17,117	\$ 17,117	\$ 16,285	\$ (832)
<b>Total revenues</b>	<u>17,117</u>	<u>17,117</u>	<u>16,285</u>	<u>(832)</u>
<b>Expenditures</b>				
General Government	17,117	17,117	16,285	832
<b>Total expenditures</b>	<u>17,117</u>	<u>17,117</u>	<u>16,285</u>	<u>832</u>
<b>Excess of Revenues over (under) Expenditures</b>	-	-	-	-
<b>Fund Balance, January 1</b>	<u>-</u>	<u>-</u>	<u>-</u>	<u>-</u>
<b>Fund Balance, December 31</b>	<u>\$ -</u>	<u>\$ -</u>	<u>\$ -</u>	<u>\$ -</u>

The public report burden for this information collection is estimated to average 380 hours annually.

<b>LOCAL HIGHWAY FINANCE REPORT</b>	<b>City or County:</b> Town of Silt In Garfield County
	<b>YEAR ENDING :</b> December 2016

This Information From The Records Of (example - City of \_ or County of \_) Prepared By: Pamela K. Woods  
Phone: 970-876-2353

**I. DISPOSITION OF HIGHWAY-USER REVENUES AVAILABLE FOR LOCAL GOVERNMENT EXPENDITURE**

ITEM	A. Local Motor-Fuel Taxes	B. Local Motor-Vehicle Taxes	C. Receipts from State Highway-User Taxes	D. Receipts from Federal Highway Administration
1. Total receipts available				
2. Minus amount used for collection expenses				
3. Minus amount used for nonhighway purposes				
4. Minus amount used for mass transit				
5. Remainder used for highway purposes				

II. RECEIPTS FOR ROAD AND STREET PURPOSES		III. DISBURSEMENTS FOR ROAD AND STREET PURPOSES	
ITEM	AMOUNT	ITEM	AMOUNT
<b>A. Receipts from local sources:</b>		<b>A. Local highway disbursements:</b>	
1. Local highway-user taxes		1. Capital outlay (from page 2)	
a. Motor Fuel (from Item I.A.5.)		2. Maintenance:	323,380
b. Motor Vehicle (from Item I.B.5.)		3. Road and street services:	
c. Total (a.+b.)		a. Traffic control operations	
2. General fund appropriations	159,937	b. Snow and ice removal	33,119
3. Other local imposts (from page 2)	254,878	c. Other	55,006
4. Miscellaneous local receipts (from page 2)	5,558	d. Total (a. through c.)	88,125
5. Transfers from toll facilities		4. General administration & miscellaneous	5,630
6. Proceeds of sale of bonds and notes:		5. Highway law enforcement and safety	118,735
a. Bonds - Original Issues		6. Total (1 through 5)	535,870
b. Bonds - Refunding Issues		<b>B. Debt service on local obligations:</b>	
c. Notes		1. Bonds:	
d. Total (a. + b. + c.)		a. Interest	
7. Total (1 through 6)	420,373	b. Redemption	
<b>B. Private Contributions</b>		c. Total (a. + b.)	
<b>C. Receipts from State government (from page 2)</b>	115,497	2. Notes:	
<b>D. Receipts from Federal Government (from page 2)</b>		a. Interest	
<b>E. Total receipts (A.7 + B + C + D)</b>	535,870	b. Redemption	
		c. Total (a. + b.)	
		3. Total (1.c + 2.c)	
		<b>C. Payments to State for highways</b>	
		<b>D. Payments to toll facilities</b>	
		<b>E. Total disbursements (A.6 + B.3 + C + D)</b>	535,870

**IV. LOCAL HIGHWAY DEBT STATUS**  
(Show all entries at par)

	Opening Debt	Amount Issued	Redemptions	Closing Debt
<b>A. Bonds (Total)</b>				
1. Bonds (Refunding Portion)				
<b>B. Notes (Total)</b>				

**V. LOCAL ROAD AND STREET FUND BALANCE**

	A. Beginning Balance	B. Total Receipts	C. Total Disbursements	D. Ending Balance	E. Reconciliation
	0	535,870	535,870	0	0

Notes and Comments:

**LOCAL HIGHWAY FINANCE REPORT**

STATE  
Colorado  
YEAR ENDING (mm/yy):  
December 2016

**II. RECEIPTS FOR ROAD AND STREET PURPOSES - DETAIL**

ITEM	AMOUNT	ITEM	AMOUNT
<b>A.3. Other local imposts:</b>		<b>A.4. Miscellaneous local receipts:</b>	
a. Property Taxes and Assessments	21,269	a. Interest on investments	
b. Other local imposts:		b. Traffic Fines & Penalties	5,558
1. Sales Taxes	221,396	c. Parking Garage Fees	
2. Infrastructure & Impact Fees		d. Parking Meter Fees	
3. Liens		e. Sale of Surplus Property	
4. Licenses		f. Charges for Services	
5. Specific Ownership &/or Other	12,213	g. Other Misc. Receipts	
6. Total (1. through 5.)	233,609	h. Other	
c. Total (a. + b.)	254,878	i. Total (a. through h.)	5,558
	(Carry forward to page 1)		(Carry forward to page 1)

ITEM	AMOUNT	ITEM	AMOUNT
<b>C. Receipts from State Government</b>		<b>D. Receipts from Federal Government</b>	
1. Highway-user taxes	101,443	1. FHWA (from Item I.D.5.)	
2. State general funds		2. Other Federal agencies:	
3. Other State funds:		a. Forest Service	
a. State bond proceeds		b. FEMA	
b. Project Match		c. HUD	
c. Motor Vehicle Registrations	14,054	d. Federal Transit Admin	
d. Other (Specify) - DOLA Grant		e. U.S. Corps of Engineers	
e. Other (Specify)		f. Other Federal	
f. Total (a. through e.)	14,054	g. Total (a. through f.)	0
4. Total (1. + 2. + 3.f)	115,497	3. Total (1. + 2.g)	
			(Carry forward to page 1)

**III. DISBURSEMENTS FOR ROAD AND STREET PURPOSES - DETAIL**

	ON NATIONAL HIGHWAY SYSTEM (a)	OFF NATIONAL HIGHWAY SYSTEM (b)	TOTAL (c)
<b>A.1. Capital outlay:</b>			
a. Right-Of-Way Costs			0
b. Engineering Costs			0
c. Construction:			
(1). New Facilities			0
(2). Capacity Improvements			0
(3). System Preservation			0
(4). System Enhancement & Operation			0
(5). Total Construction (1) + (2) + (3) + (4)	0	0	0
d. Total Capital Outlay (Lines 1.a. + 1.b. + 1.c.5)	0	0	0
			(Carry forward to page 1)

Notes and Comments: