

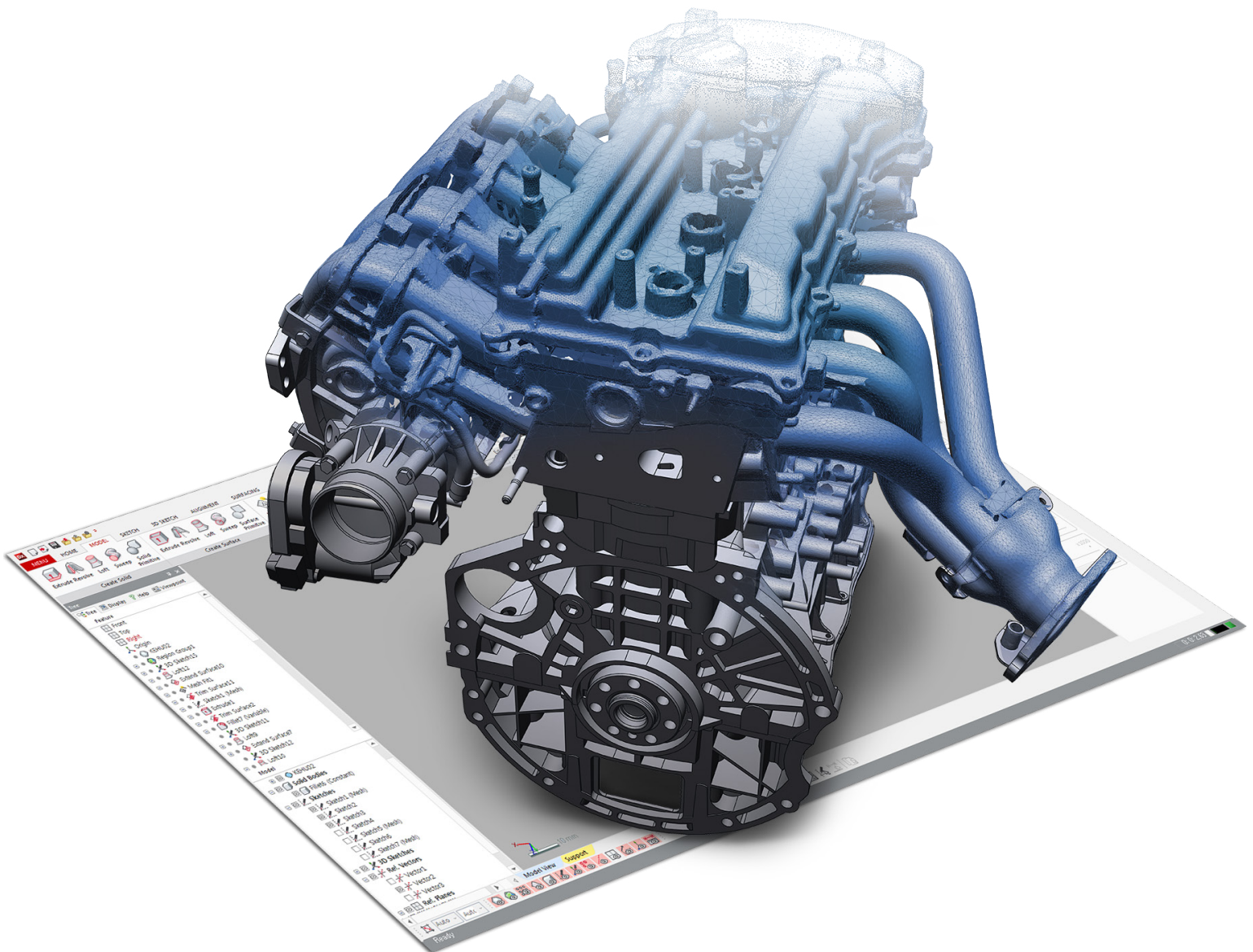

Geomagic Design X

Release Note

Release Date: May, 2022



OQTON

TABLE OF CONTENTS

1. INTRODUCTION	1
2. INSTALLATION	2
System Requirements	2
Download and Install software	2
Activate License	2
3. NEW FEATURES AND ENHANCEMENTS	3
What's New In 2022.0.0	3
Improvements to Loft	3
Improvements to Exact Surfacing	3
LiveTransfer To Latest CAD Software Versions	4
Improvements to Sketch Tools	4
New Centered Rectangle	4
Fit Polyline Option for Rectangle	5
Snap Sketch to Another Sketch	5
Midpoint Constraint	5
Snap Sketch to Reference Point	5
Replace Target Mesh	6
Converted Sketch	6
Tangent Magnitude for 3D Spline	6
Display Type for Circular Dimension	7
Split 2D Sketch Entity	7
CAD Tessellated Mesh Segmentation	8
New Hexagon Structured Light Scanner Interface	8
Hardware Interface Updates	9
File Import	10
Auto-Save & Recovery	10
Save Design in Rolled Back State	10
Improvements to Accuracy Analyzer	11
Normal Vector Filter	11
Reference Mesh for Comparison	11
Improvements to Smart Selection Tool	12
3D Mouse	12
Miscellaneous Enhancements	13
Licensing & Installer	16

4. BUG FIXES.....	17
Bug Fixes in 2022.0.0.....	17
Known Issues in 2022.0.0.....	21

1 INTRODUCTION

INTRODUCING GEOMAGIC® DESIGN X™

Version 2022

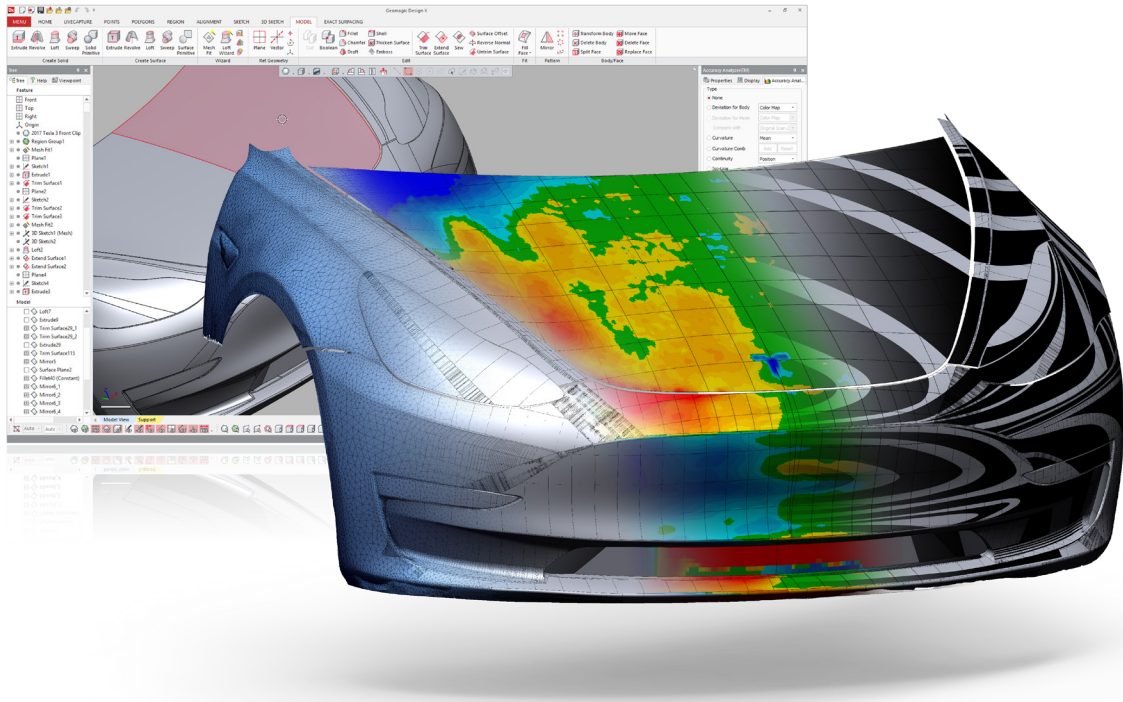

From Scan to CAD in no time

Bring physical parts into digital parametric CAD models with a reverse-engineering software that combines history-based CAD with 3D scan data processing. Geomagic® Design X™ is the industry's most comprehensive reverse engineering software, combines history-based CAD with 3D scan data processing so you can create feature-based, editable solid models compatible with your existing CAD software.

What Can You Do with Geomagic Design X?

Geomagic Design X converts 3D scan data into high-quality, feature-based CAD models. The software combines automatic and guided solid model extraction in a unique way while being incredibly accurate.

Scan virtually anything and create producible designs.

- Rebuild CAD data for broken tools and molds.
- Recreate lost CAD data for parts and molds.
- Design custom products.
- Convert physical parts into CAD for new product designs.
- Make existing parts fit with new parts.

2 INSTALLATION

System Requirements

For the latest system requirements information and to learn about specific qualified system configurations, go to the [System Requirements](#) page in the Geomagic Support Center. Some users have had success running system configurations that deviate from the supported listed on our website. In such cases, these configurations are not officially supported by Oqton. Additionally, we test a variety of hardware platforms in combination with the graphics subsystems. While we make every attempt to be as thorough as possible, hardware manufacturers change their products frequently and may be shipping newer products or have discontinued active support for others. Check the support section of the website for the latest system requirement information and specific qualified systems.

Download and Install software

You can download and install the software from support.3dsystems.com/s/software-support-3dsystems, select the Geomagic Design X product, then select to download Geomagic Design X.

In addition, automatic software updates are available if you set the **Update Product Automatically** option to **True** in Preferences and a valid maintenance code is activated, and your computer is connected to the Internet. The application will check if a newer version is available and will download it automatically for installation.

You can also manually check if a newer version is available by going to **Help > Check For Update**.

Activate License

Geomagic Design X requires license activation to run the application on your PC. You can choose to use a trial license for a 15-day period or activate a permanent license.

After you start your application, the License Manager window opens. The License Manager allows you to activate and use the Geomagic Design X software.

NOTE: When the License Manager is launched, you can click the **Help ? button found at the top right corner of the window to read the [CimLM Licensing Guide](#).**

You should have received an email from Oqton with your activation code. If you have not received an email from Oqton, visit the Contact Us page at: <https://support.3dsystems.com/s/contact-support-page>, and find the details to contact the support team depending on your product and region.

For more information, go to the [CimLM Licensing Support](#) page.

3 NEW FEATURES AND ENHANCEMENTS

What's New In 2022.0.0

New features in this release were made to deliver more efficient, and new workflows for complex designs. They also improve the speed of modeling of today's more common and challenging parts. This release also includes major enhancements and various bug fixes to make your experience easier and comfortable.

Note: The **DX-E** label indicate features that are also available in Geomagic Design X Essentials software package.

Improvements to Loft **DX-E**

Achieve the intended design by utilizing advanced modeling options.

CHALLENGE:

There needs to be more options to control tangency for guide curves and to define connectors so that the user has more control over the loft feature definition.

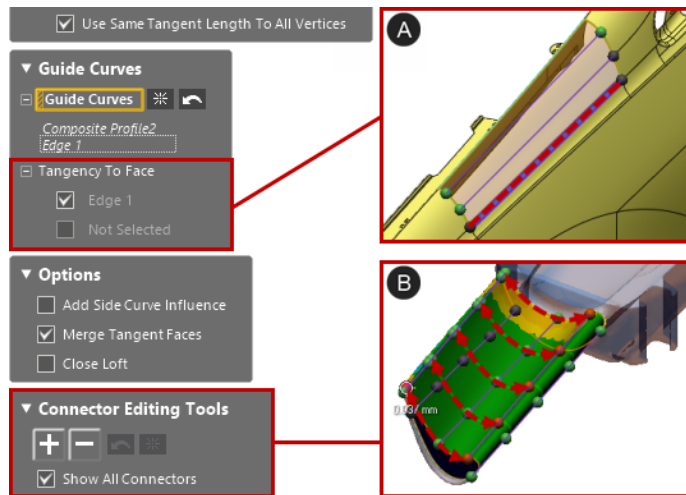
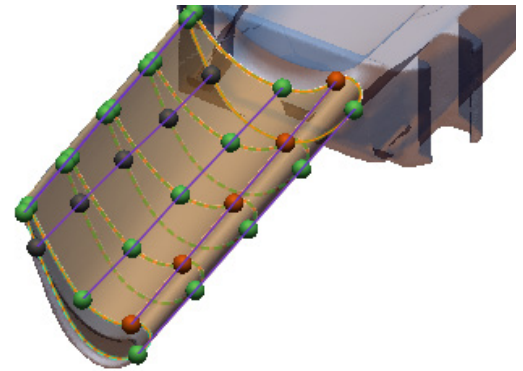

SOLUTION:



Tangency to Faces

A new **Tangency To Face** option has now been added, allowing you to control tangency for selected guide curves.

Note: This option is available only for surface bodies.



Connector Editing Tools

New **Connector Editing Tools** have been added to the Loft command. You can now add, delete, and edit connectors to control over influence of lofted surface.

Improvements to Exact Surfacing **DX-E**

Save time by reusing auto-surface patch networks when creating surface patches manually.

CHALLENGE:

There needs to be a new option to keep patch networks created by auto-surfacing for later surface patch works.

SOLUTION:

A new **Keep Patch Network in the Tree** option has been added to the Auto Surface command, allowing you to keep patch network created by auto-surfacing for later design works.

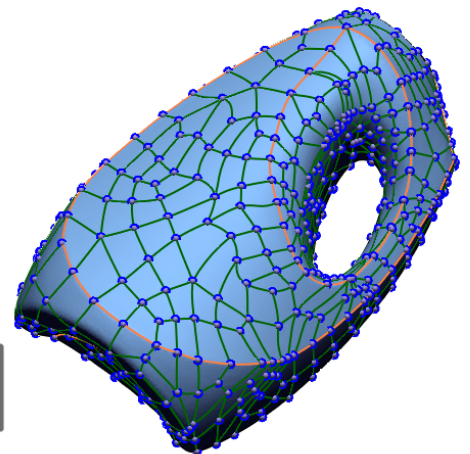
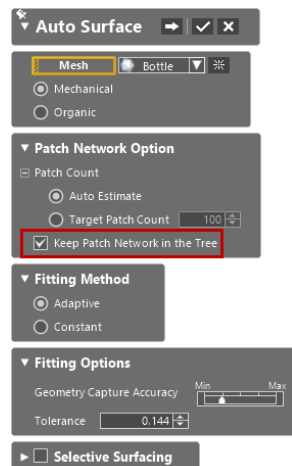

LiveTransfer To Latest CAD Software Versions

The following CAD applications are now supported in LiveTransfer:

- SOLIDWORKS 2022 (Now supported for SOLIDWORKS 2006 to 2022)
- Inventor 2021, 2022, and 2023 (Now supported for Inventor 2010 to 2023)
- Creo 8.0, and 9.0 (Now supported for Creo up to 9.0)
- NX 1899, 1926, and 1953 series (Now supported for NX 8 to 1953 series)

Additionally, the **LiveTransfer to SOLIDWORKS** has been improved so that the custom templates set in the SOLIDWORKS application can be used when transferring models to SOLIDWORKS.

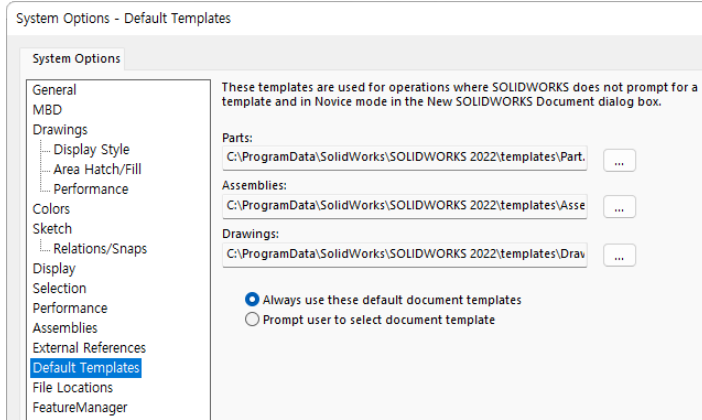

System Options in SOLIDWORKS

Improvements to Sketch Tools **DX-E**

Increase productivity by using improved sketching tools. The following improvements were made to the Sketch tools:

New Centered Rectangle

The new **Centered Rectangle** command has been added as a new sketch entity type. This command allows you to quickly create a rectangle from a center point on a sketch plane.

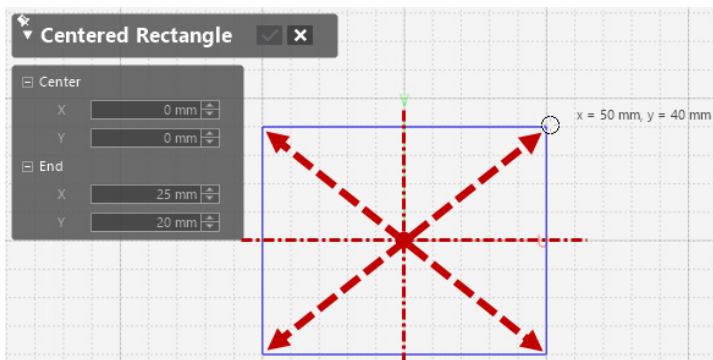

Fit Polyline Option for Rectangle

The **Fit Polyline** option is available for Rectangle. You can now fit a rectangle to selected polyline just in a second.

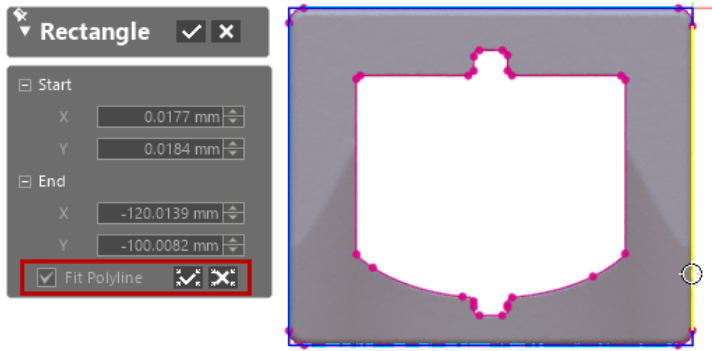

Snap Sketch to Another Sketch

You can now drag and snap selected sketch entities to another sketch entities.

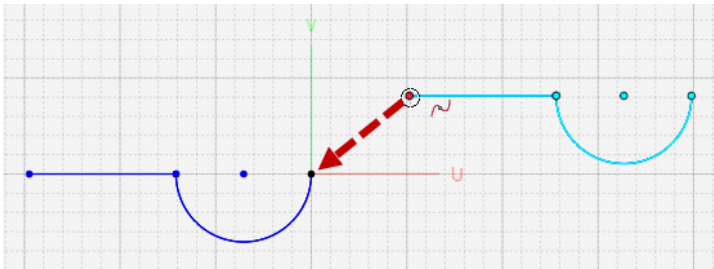

Midpoint Constraint

The **Midpoint** constraint is now available between line/arc and point.

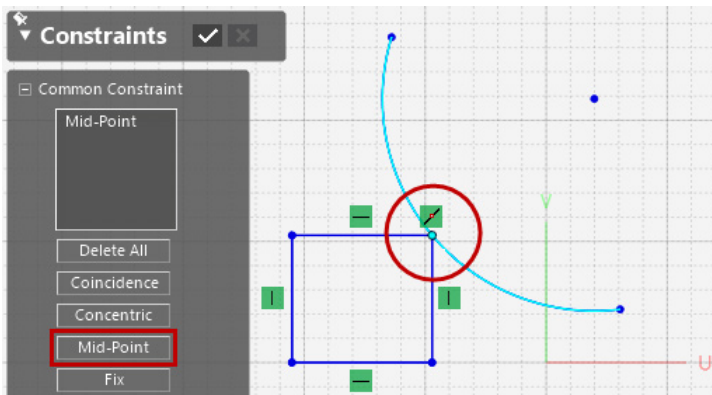

Note: Creating the mid point constraint is available only for line and arc sketch types.

Snap Sketch to Reference Point

You can now drag and snap a sketch to 3D reference points regardless of the view orientation of the sketch plane.

Replace Target Mesh

You can now reuse an existing mesh sketch by replacing with a new target mesh.

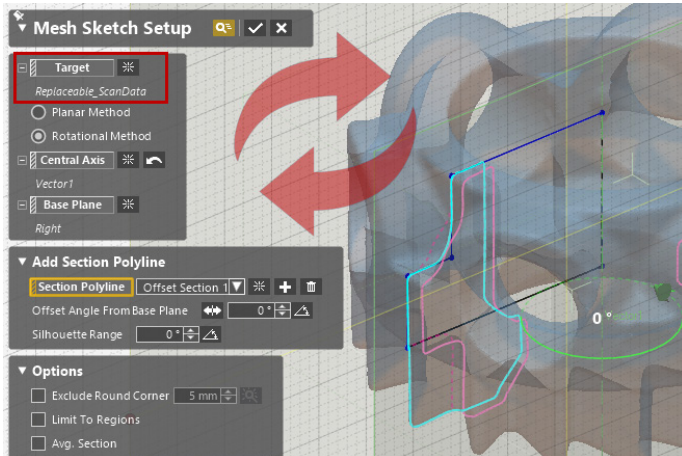

Converted Sketch

The entity conversion has now been improved for circle so that the geometry of a converted circle has the same geometry as an original circle.

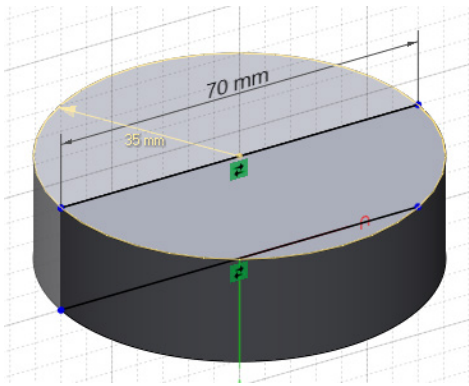

Tangent Magnitude for 3D Spline

You can now specify the tangent magnitude for 3D spline.

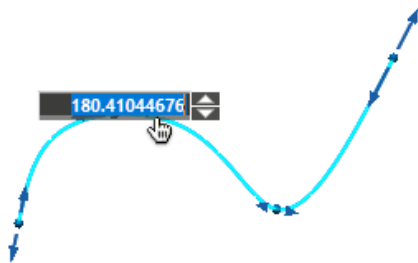

Display Type for Circular Dimension

You can now choose the display type of circular dimensions when dimensioning circular entities. Changing the display type is also available in the Properties of dimensions. This supports selection for multiple circular dimensions.

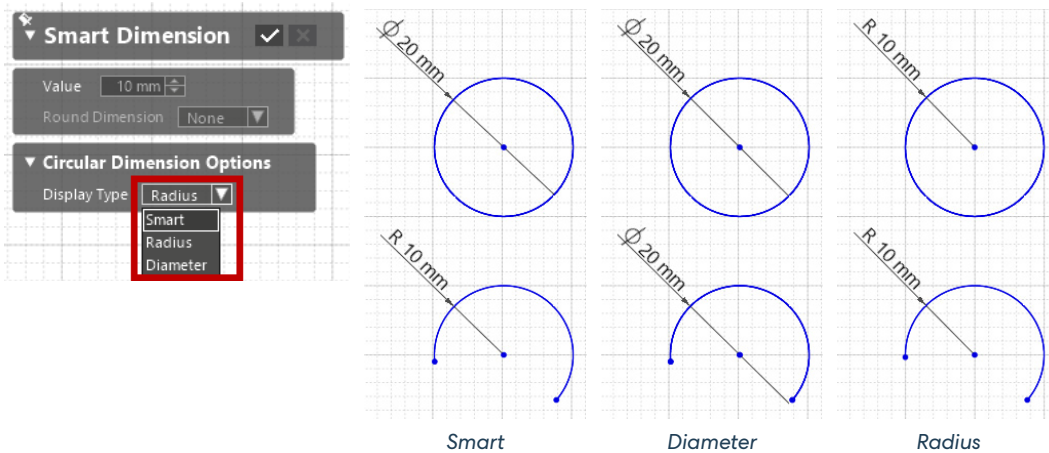

Note: After adding circular dimensions, the display type of the circular dimensions can be changed in the Properties.

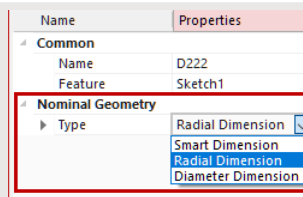

Split 2D Sketch Entity

Split lines, arcs, and splines. You can now split a 2D sketch entity at intersection points of selected sketch entities by using a new **Curves At Intersection Point** option added to the Split command.

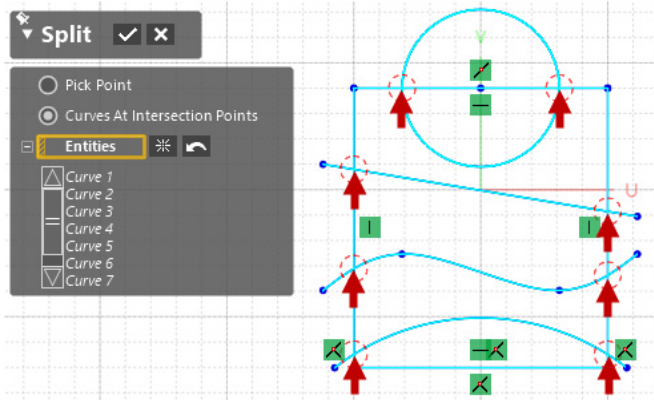

CAD Tessellated Mesh Segmentation

Increase productivity of downstream operations such as alignment and modeling with improved quality and faster performance of region segmentation for a mesh tessellated from CAD.

CHALLENGE:

The quality of region segmentation needs to be improved for a mesh tessellated from CAD.

SOLUTION:

A new Region Segmentation algorithm has been implemented, improving the quality of region segmentation for a mesh tessellated from CAD. A newly added **CAD Tessellation Mesh** option allows you to achieve a high quality of region segmentation for CAD mesh models.



Geomagic Design X 2022.0.0

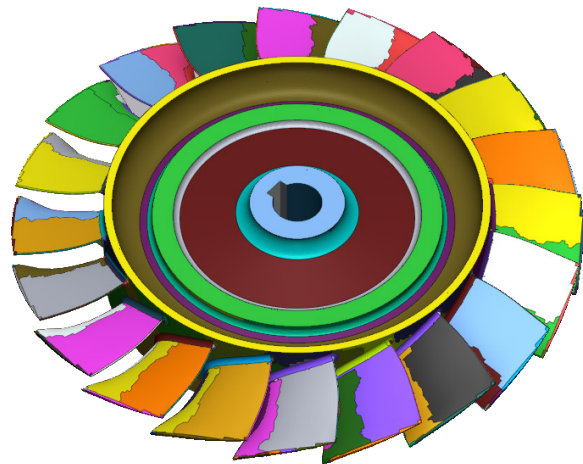

Geomagic Design X 2020.0.4

New Hexagon Structured Light Scanner Interface

Geomagic Design X offers the Scanner Direct Control that enables the use of various scanning devices directly within the application.

CHALLENGE:

Enable to use the Hexagon Structured Light Scanners within Geomagic Design X.

SOLUTION:

A new Plug-In for **Hexagon Structured Light Scanners** has newly been implemented. You can now connect Hexagon Structured Light Scanner Interface and directly scan objects in Geomagic Design X without using the Optocat application.

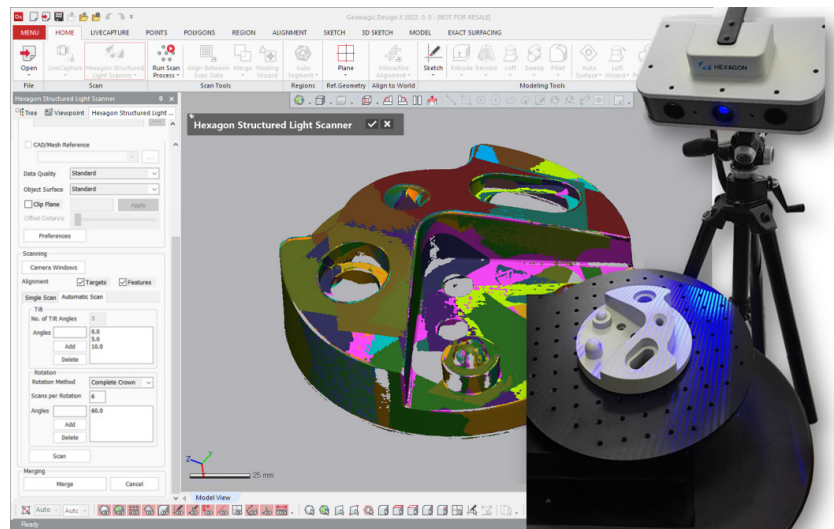

Hardware Interface Updates

The following hardware are now supported in Scanner Direct Control and LiveCapture:

- **Scanner Direct Control**

- **Shining 3D Einscan scanner**

This is available in the following location: *Insert > Scanner Direct Control > Shining3D*



- **LiveCapture**

- **Leica AT960 tracker + Absolute AS1 scanner**

This is available in the following location:

Hexagon Absolute in LiveCapture



Note: The Romer Absolute device has now been renamed "**Hexagon Absolute**". To use the Leica Absolute Scanner, select **Hexagon Absolute** on the Device List in LiveCapture.

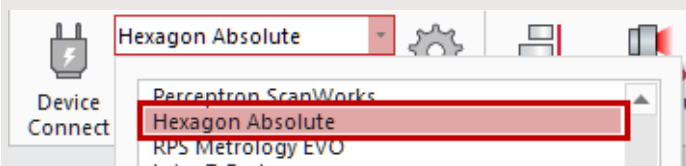

- **Faro Quantum Max/S + LLP XR/HD**

This is available in the following location:

FaroArm/ScanArm in LiveCapture



File Import

Native CAD File Import has been updated to support the following versions:

CAD Application	File Extension	Version Supported	Comments
CATIA V5	.catpart, .catproduct	R8 - V5-6 R2021	Geometry Only
CATIA V6	.catpart, .catproduct	Up to V6 R2021x	Geometry Only
Creo (Pro/E)	.prt, .prt.*, .asm, .asm.*	Pro/E 16 – Creo 8.0	Geometry Only
Inventor	.ipt, .iam	V6 - 2022	Geometry Only
SIEMENS NX	.prt	11 – NX1980	Geometry Only
SOLIDWORKS	.sldprt, .sldasm	98-2022	Geometry Only (2016-2021)
STEP	.stp, .step	AP203, AP214, AP242	Geometry Only
AutoCAD DXF	.dxf	2.5 - 2022	Geometry Only

Auto-Save & Recovery **DX-E**

The new options for supporting auto-save and recovery working files have newly been added. These options allow you to more safely protect your working files from unexpected application crashes.

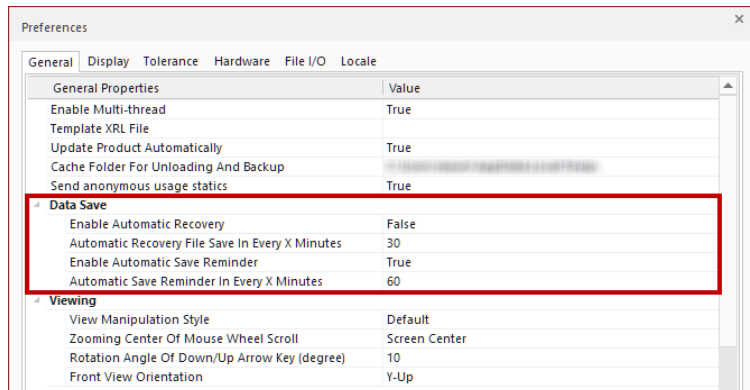

Note: In case of application crash, you will receive a notification and can decide the following operations:

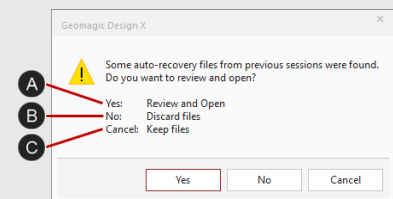

- A Yes:** Browse to the location of the auto-saved files.
- B No:** Discard reviewing the auto-saved files.
- C Cancel:** Keep them to review at the next launch .

Save Design in Rolled Back State **DX-E**

Save the file in a rolled back state. Continue to work without having to roll the working state to the end to save a file.

Improvements to Accuracy Analyzer DX-E

The following improvements were made to the Accuracy Analyzer:

Normal Vector Filter

A new **Normal Vector Filter** option has now been added to the Accuracy Analyzer. This allows you to ignore the normal direction of target measurement bodies while analyzing deviations for body.

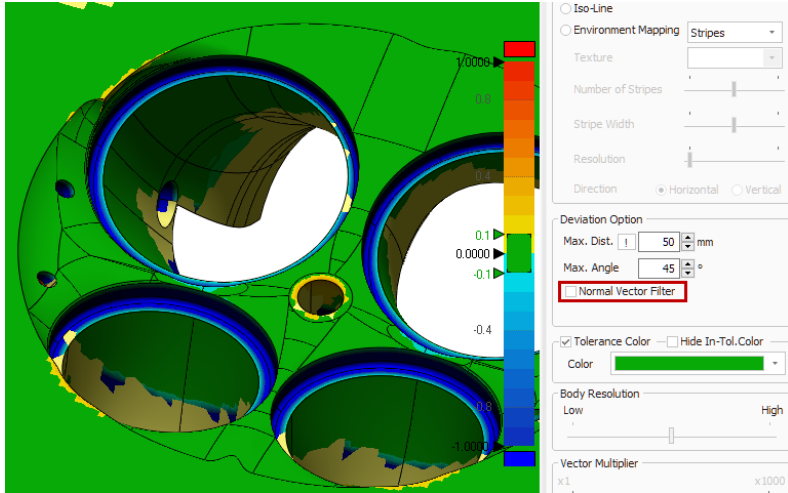

Reference Mesh for Comparison

You can now choose the reference mesh for deviation comparison.

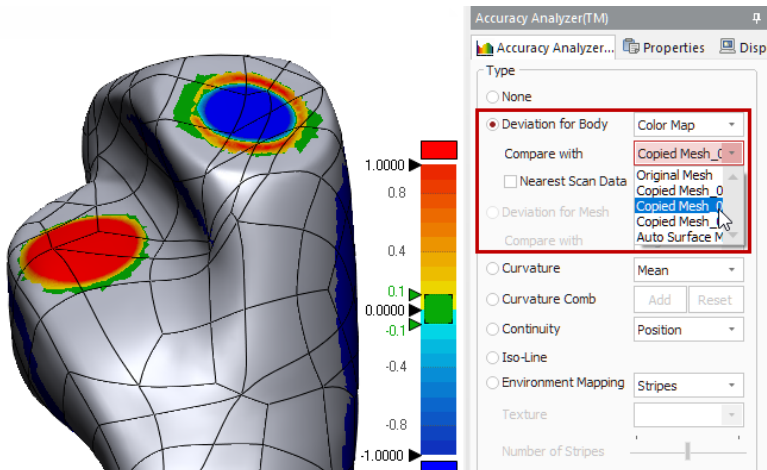

Miscellaneous Enhancements

- **Feature name** **DX-E**

- Used the feature to name a created body, e.g., <Mesh Fit> instead of <Imported Body 1> when creating a surface using the Mesh Fit command.
- Retained the model's name when converting solid/surface body to mesh.
- Retained the model's name when importing neutral CAD files such as STL, IGES, and Parasolid files to the application.
- Feature can be renamed by right-clicking on it and click **Rename**.

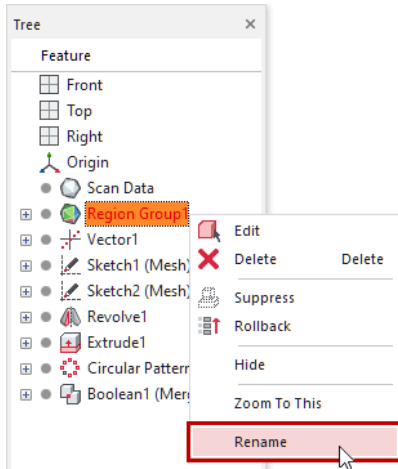

- The model name is used as the default file name when exporting solid or surface bodies.

- **Assign different colors to scans** - A new **Assign Different Colors** option has been added to the ScanData tab of the LiveCapture Settings. While scanning with the LiveCapture, obtained scans are added with different material colors.

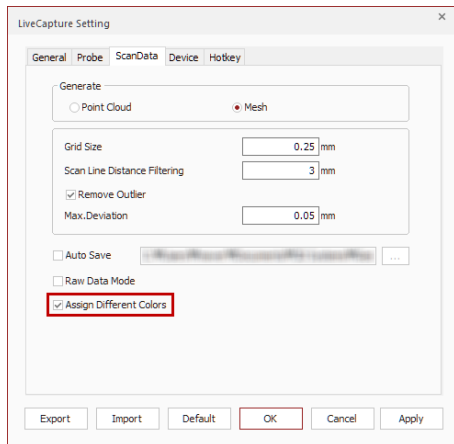

- **View clip** **DX-E**

- The **View Clip** can now be set from the selection expanded to regions, mesh, and CAD entities.
- New options for editing and resetting View Clip have now been added to the Context Menu. You can edit the View Clip by clicking the options in the Context Menu.

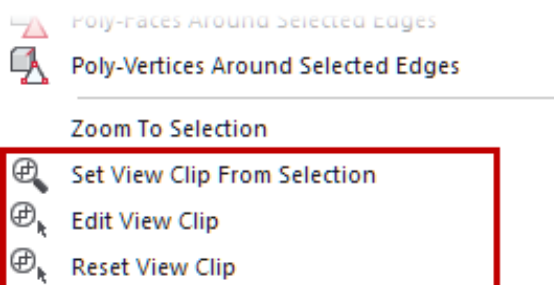

- **Show selected entities only** **DX-E**

The applicable scope of the **Show Selected Only** option has been expanded to a selected area on a mesh.

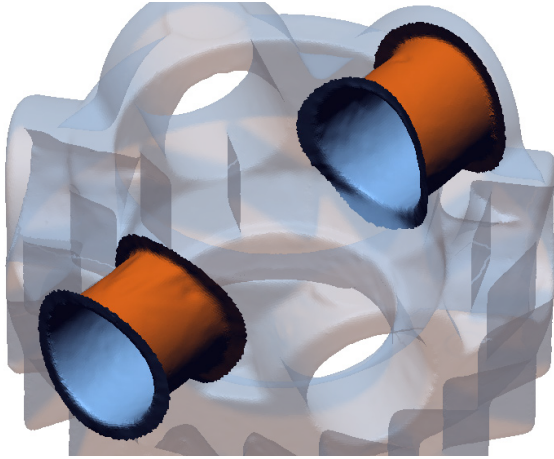

- **Easy access to visibility controls** **DX-E**

You can now easily turn on or off the visibility of entities from the Upper-Side Toolbar.

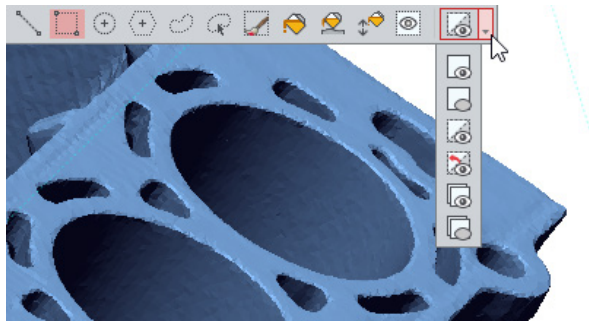

- **Transform geometries** **DX-E**

You can now select reference geometries and move them while aligning scan data. Due to the new **Select Geometries to Move** option, any probed reference geometries can now be bound to the scan data and moved together.

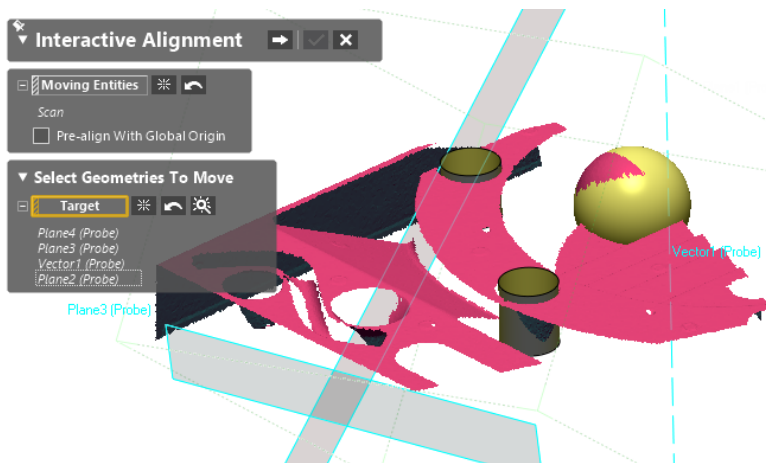

- **Continue scanning / probing** - When clicking the 'B' button on a measuring device to stop scanning or probing, you can now decide whether to continue with the current operation, or to stop and proceed to the next operations.

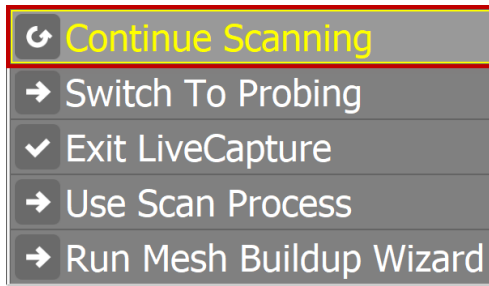

Continue Scanning

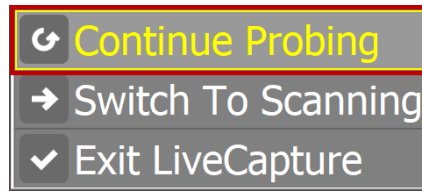

Continue Probing

- **Large data handling** **DX-E**
Improved the performance of large scan data handling.

- **Export surface or solid bodies via Batch Process**
You can now design a batch process to allow to export solid and surface bodies selectively.

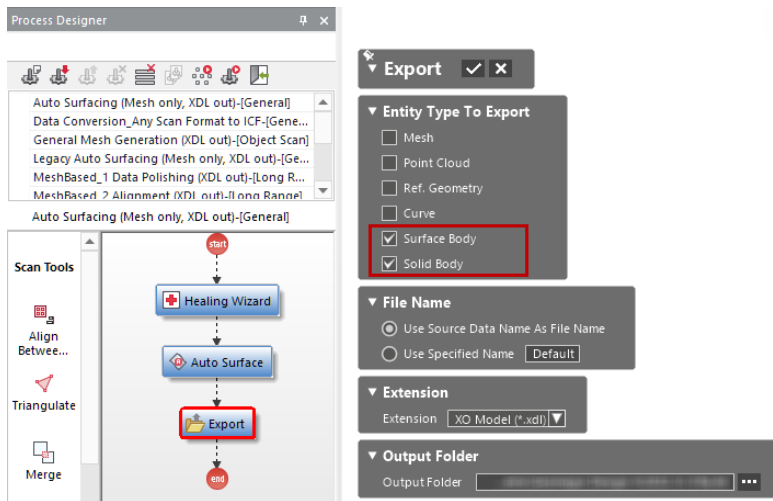

- **Repositioned Import command** **DX-E**
The Import command has now been relocated under the File menu for a better understanding of the design workflow.

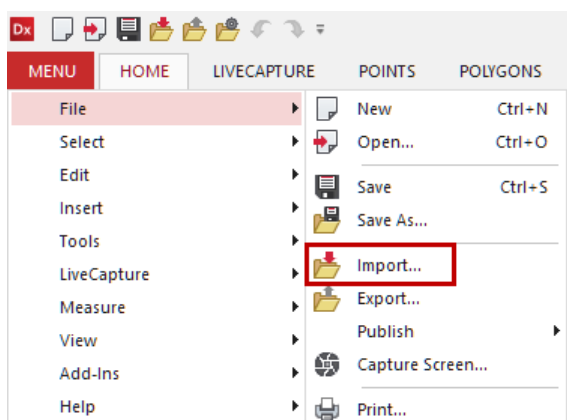

- **Rotation center** **DX-E**

You can easily set the rotation center of the view by middle-clicking on any point on the Model View.

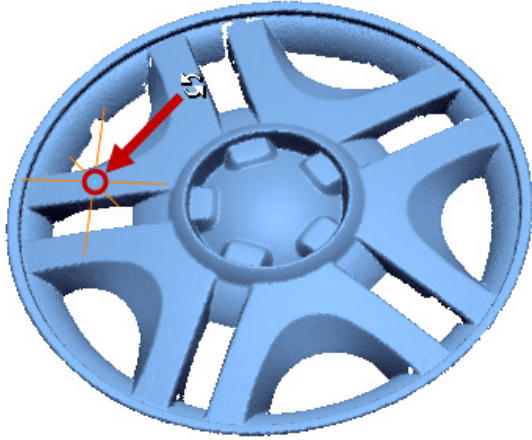

- **Capture screen** **DX-E**

- Dimension texts can also be captured with entities.
- The last used values are remembered for later use.

Licensing & Installer **DX-E**

The following improvements were made to the Licensing System and the Installer:

- The language that was set in the previous version is retained when the user auto-updates to the newer version.
- The licensing system has been more robust to prevent activation errors and lost licenses in some cases.
- The Auto-Update capability is now prevented from being installed by passing command-line arguments, "Setup.exe /nouupdate" during installation.

4 BUG FIXES

Bug Fixes in 2022.0.0

This section lists issues that have been resolved since Geomagic Design X v2020.0.4:

Note: The **DX-E** label indicate features that are also available in Geomagic Design X Essentials software package.

Common

- **GDX-7534:** In the **Accuracy Analyzer**, strange deviation results were made depending on the normal direction of target faces of a reference surface body.
DX-E
- **GDX-7480:** Clearing area selections were not reflected in the dialog tree when using the **Mesh Fit** or the **Loft Wizard** command.
DX-E
- **GDX-11218:** The following issues were found when using the **Customize Ribbon** command.
DX-E
 - Commands that did not exist in the current Ribbon menu were in the list of the **Customize Ribbon Menu** and they were not removed from the list.
 - When adding a command to the custom Ribbon menu, the list collapsed and the command could not be added to the list.
- **GDX-6823:** When disconnecting a second monitor, the **Preferences** window working on the second screen didn't move to a connected screen.
DX-E
- **GDX-13515:** When turning the Sound options off in the **Preferences**, it continued to work in non-English locales.
DX-E
- **GDX-13414:** When clicking **Probing** operation in the **LiveCapture** without clicking the 'B' button on a connected scanner, scans obtained with the **Laser Scanning** operation were not added to the Feature Tree.
- **GDX-15628:** When capturing entities on a second monitor with different screen resolutions, the size of the entities was captured differently.
DX-E
- **GDX-7739,**
GDX-7849,
GDX-11274,
GDX-15178: When capturing sketch entities, dimensions were excluded from the captured screens.
DX-E
- **GDX-16569,**
GDX-16373: Only a user with an administrator privilege could launch the application for the first time.
DX-E
- **GDX-3618,**
GDX-892,
GDX-14117: In the **2D Sketch**, the maximum zoom-out was limited to 250mm by default. As a result, it was not allowed to select an entire sketch if its size was too large to be viewed in the max zoomed-out Model View.
DX-E
- **GDX-16060,**
GDX-14187: Entity selection and deselection were sometimes possible with the right mouse button.
DX-E
- **GDX-15977:** The application would crash on launch with multiple PCs.
DX-E
- **GDX-15202:** Activation errors came up when activating the application with a license used in an old version of **CimLM**. The following workarounds are recommended to avoid this issue:
DX-E
 - Update the license on a new version of the License Utility
 - Deactivate and reactivate the license on a new version of the License Utility
- **GDX-15246:** The default keyboard shortcuts didn't remain when resetting keyboard shortcuts; only custom shortcuts need to be removed when resetting.
DX-E
- **GDX-13567:** The **Small Icon Only** option applied to individual commands in the **Customize Ribbon** command didn't remain as it applied after clicking on the menu.
DX-E
- **GDX-15773:** The application would crash after a few seconds.
DX-E

- **GDX-15929:**
DX-E There were the wrong guides in the **Mouse Helper**.
- **GDX-16066:**
DX-E When clipping the view by using the **Set View Clip From Selection** command, a clipping box that was too tight to control was created. As a result, many unexpected flickering issues occurred while manipulating the clipping box.

Sketch Tools

- **GDX-13845,**
GDX-15190,
GDX-15632:
DX-E When changing a target scan data to reuse existing sketches for a new scan data, the section polyline always took into account the original scan data.
- **GDX-16672,**
GDX-11984:
DX-E The **Pierce** constraint was not available between a point and an existing 2D sketch outside the sketch plane.
- **GDX-16297:** The application would crash when adding a constraint between a helix curve and a point.
- **GDX-16299:**
DX-E The selection of end-points of a copied sketch didn't remain after copying from an existing sketch.

Scan / Mesh Tools

- **GDX-12212:**
DX-E The value in the **Reduction Ratio** input box in the **Decimate** command didn't remain as it was entered.
When re-entering the following commands with the preselected area by using the Ctrl + Spacebar shortcut key, the selection became changed inversely.
 - **Defeature** **DX-E**
 - **Enhance Shape**
 - **Smooth** **DX-E**
 - **Offset**
- **GDX-12921:**
- **GDX-14307:**
DX-E The application would crash while running the **Global Remesh** command if the target mesh had a texture.
- **GDX-16611:**
DX-E The application became unresponsive when applying the **Merge** or the **Combine** command to meshes or point clouds exceeded a certain number.
- **GDX-13349:** The **Rolling Radius** status in the **Normal Information Wizard** command didn't roll back to the previous status when undoing.
- **GDX-8373,**
GDX-13320: Changes were not discarded on click of the **Cancel** button after applying the **Normal Information Wizard** command to selected poly-faces.
- **GDX-15294:** Cracks were found on the mesh as the result of the **Offset** command.
- **GDX-15666:**
DX-E The **Min. Edge Length** option in the **Convert To Mesh** command didn't affect the result.
- **GDX-15663:**
DX-E Scan data disappeared off the screen after scan data processing on **AMD Ryzen Threadripper 3990X** and **AMD Ryzen Threadripper PRO 3995WX** Processor.
- **GDX-14664:**
DX-E The **Fill Holes** command would work only when all selected holes were fillable.
- **GDX-11073:** Failed to trim a mesh with a 3D mesh sketch in certain cases.
- **GDX-13457:** After separating a mesh that was imported with **Double** poly-vertex precision, the precision was suddenly changed to **Float**.

Modeling Tools

- **GDX-14783:**
DX-E When applying a new fillet radius to an edge of a model while using the **Variable Fillet**, the fillet didn't update with the new radius value.
- **GDX-2255:**
DX-E Failed to apply the **Extrude** with the **Result Operators (Cut and Merge)** to the model imported from a Parasolid file.

- **GDX-13205:** The number of spline points in the second stage was always fixed at 5 when running the **Loft Wizard** for the first time regardless of the Smoothness rate.
- **GDX-13413:** Could not go to the second stage in the **Loft Wizard** when the No. of Sections was set to 2 with the By Curve path.
- **GDX-16674,** When using the **Datum Alignment** method in the **Transform Body** command, there were many geometric regions and CAD faces that could not be selected depending on the relationship between Datum pairs.
- **GDX-11697:**
- **GDX-16622,**
- **GDX-16293:** Could not change the position of a loft connector on a circle profile with no endpoint.
DX-E
- **GDX-16741:** When clearing some of the selected composite profiles in the **Loft** command, the preview disappeared and the command became inapplicable.
DX-E
- **GDX-16521:** The application would crash when rebuilding a path curve in the **Sweep Wizard** command.
- **GDX-16625:** When the **Constant Width** option was selected for the **Face Fillet** in the **Fillet** command, the **Radius** option didn't change to "**Width**".
DX-E

Exact Surfacing

- **GDX-12317,** The **Extend Boundaries** option didn't work when applying the **Auto Surface** with the **Selective Surfacing** and the **Boundary Smoothing Iterations** options. This sometimes caused the application to crash when going to the second stage.
GDX-12128:
- **GDX-12013:** After applying the **Auto Surface** with the **Selective Surfacing** and the **Fill Trimmed Boundary Only** options, an error message appeared that says the surface fitting failed, and a trimmed mesh containing many defects was created.
- **GDX-11893:** The application would crash when clicking Update to reanalyze defects after readjusting high-deviation patches in the **Repair Patches** command.
- **GDX-11751,** After editing a patch network manually, wrong patch groups were detected in the **Shuffle Patch Groups** command.
GDX-4057,
GDX-9830:
- **GDX-11439:** The application became unresponsive while creating a curve network by using the **Selective Surfacing** options in the **Auto Surfacing** command.

Region Tools

- **GDX-15297:** Applying the **Auto Segmentation** with high sensitivity would cause the application to be slow.
- **GDX-13478,** The **Mesh From CAD or CAE Software** option in the Auto Segment command didn't work properly. The region segmentation algorithm has now been improved for CAD tessellated mesh and this option has been renamed "**CAD Tessellated Mesh**".
GDX-4369:
- **GDX-14948:** The application would crash when applying a custom viewpoint to a mesh with regions.
DX-E

Hardware Interface

- **GDX-2670,**
GDX-724,
GDX-233, The **3dconnexion SpaceMouse** didn't work in Geomagic Design X.
GDX-3128:
DX-E
- **GDX-17063:** The application would crash while probing with **Creaform Optical CMM** in **LiveCapture**.
- **GDX-17061,** The calibration optimization didn't work for Creaform Portable 3D Scanners.
GDX-17324:

LiveTransfer

- **GDX-15242:** The **Use Custom NX Execution File Path** option in the **LiveTransfer to NX** command didn't work properly.
- **GDX-13974:** Failed to transfer a model to **Creo 6.0**.
- **GDX-15244:** LiveTransfer to **Creo 7.0** or **later versions** continued to stop due to many pause errors.
- **GDX-15229:** Failed to transfer surface bodies created by the Mesh Fit command to **Creo 7.0**
- **GDX-12310:** Failed to transfer a model to **NX 1847**.

File I/O

- **GDX-15148,**
GDX-14273,
GDX-14498,
GDX-12319,
GDX-5173:
DX-E Failed to import .E57 files into the application.
- **GDX-2683:**
DX-E The application became unresponsive when importing certain Parasolid files.
- **GDX-13060:**
DX-E When saving point clouds with colors as an .XRL file, the colors were excluded from the file.
- **GDX-12998:**
DX-E A mesh saved as an .XDL file was always imported into the application as a point cloud.
- **GDX-13664,**
GDX-11569,
GDX-10750: After running the **Run Mesh Buildup Wizard** on import for multiple mesh files, the original meshes were listed on the Model Tree, but not shown in the Model View.
- **GDX-11978:** The application would crash when clicking **Skip** to skip all the remaining steps of the **Mesh Buildup Wizard** that ran when importing scan files.
- **GDX-15654,**
GDX-15626: Failed to import an .OBJ file with textures into the application.
DX-E
- **GDX-11533:**
DX-E Failed to import an .CXProj file saved in the old version of Geomagic Control X into the application.
- **GDX-16065:**
DX-E The application would crash on import for certain files.
- **GDX-16596:**
DX-E Failed to open an .XRL file in certain cases.
- **GDX-16695,**
GDX-16982: Failed to import large scan data and became unresponsive on load in certain cases.
DX-E

Known Issues in 2022.0.0

This section lists known issues that need to be addressed for next versions:

- **GDX-17093:** After transforming scan data with reference geometries by using the **Transform Scan Data** command, the labels of the reference geometries are still in their original position.
- **GDX-17250:** 3D patch network created by auto-surfacing is not transferred to SOLIDWORKS.
The center point of a centered rectangle is not selected by the Select All command or the Ctrl + A shortcut key, and still remains after deletion. To delete the remained point, select it and delete by going to **Edit > Delete** or pressing the **Delete** key.
- **GDX-17092:** When scaling the size of scan data by using the **Transform Scan Data** command, the size of the reference geometries that are selected with the target scan data is scaled accordingly. The size of the reference point is incorrect only during the previewing stage. The size becomes correct after running the command.
- **GDX-17316:** When transforming scan data with reference geometries by using the **Transform Scan Data** command, the **Estimate** button in the **Select Geometries To Move** option doesn't work for the geometries that are not visible in the Model View.
- **GDX-17231:** The start point of the loft connector isn't fixed on the node point of a curve. It depends on the properties of the curve.
- **GDX-17428:** The **Show Selected Only** command may cause display performance to be slower than normal while viewing meshes partially.
- **GDX-17362, GDX-17459:** While the application is minimized, auto-recovery files without thumbnails may be saved.
- **GDX-17449:** In LiveCapture, the **Assign Different Colors** option doesn't work for scans being captured after the measuring mode is changed from the Probing mode.
- **GDX-17545:** In LiveCapture, the **Assign Different Colors** option turns automatically off when capturing scans using the Clipping Plane option.
- **GDX-17577:** After splitting sketches, unnecessary **Coincidence** constraints are created in some cases.
- **GDX-17584:** While transferring a model to **NX 1926** or **NX 1953**, the transfer of some Extrude features fails.



Oqton, Inc.
345 California St, Suite 600 San Francisco, CA 94104
www.oqton.com

Copyright © 2022 Oqton, Inc. All rights reserved.