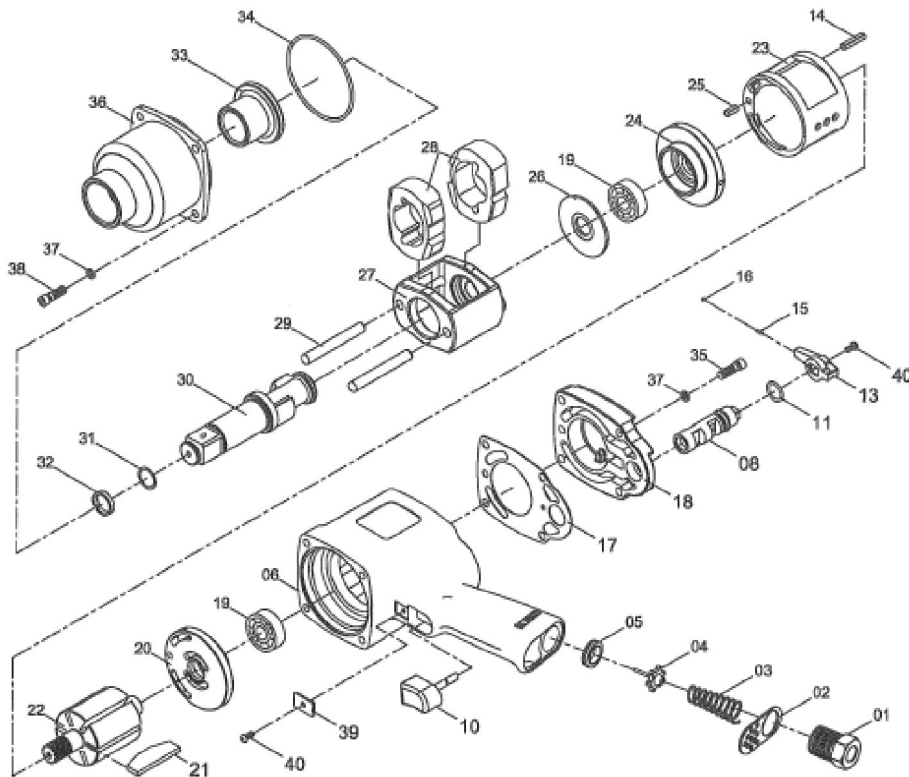

SPECIFICATIONS

Drive.....	3/4"
Free Speed.....	7,250 RPM
Working torque.....	200-800 ft.lbs
Maximum torque.....	1100 ft.lbs.
Length.....	8.54 in.
Weight.....	9.1lbs.
Air inlet.....	1/4" NPT
Average air consumption.....	8 CFM
Maximum operating pressure.....	90 PSI

Parts Breakdown for UT8340C-1
USE ONLY IMPACT SOCKETS & ACCESSORIES

Sockets and accessories used shall be of the impact socket type. Always check sockets, retainers and drives regularly for wear or damage and replace whenever necessary

Replacement Parts for UT8340C-1

POS#	PART#	DESCRIPTION	Q'TY
1	9828059	FIXED INLET BUSHING	1
2	9212-01602	EXHAUST DEFLECTOR	1
3	9113-00324	THROTTLE VALVE SPRING	1
4	9828062	THROTTLE VALVE	1
5	9828063	THROTTLE VALVE SEAT	1
6	9640-00118-STC	MOTOR HOUSING	1
8	9828065	REVERSE VALVE	1
10	9828066	TRIGGER	1
11	9828067	O-RING	1
13	9828068	REVERSE VALVE KNOB	1
14	9828069	SPRING PIN	1
15	9828070	SPRING	1
16	9828071	STEEL BALL	1
17	9828072	GASKET	1
18	9828073	HOUSING CAP	1
19	9828074	BALL BEARING	2
20	9828075	REAR PLATE	1
21	9828076	ROTOR BLADE	6
22	9828077	ROTOR	1
23	9828078	CYLINDER	1
24	9828079	FRONT PLATE	1
25	9828080	SPRING PIN	1
26	9828081	HAMMER FRAME REAR	1
27	9828082	HAMMER CAGE	1
28	9828083	HAMMER	2
29	9828084	HAMMER PIN	2
30	9810-003061	ANVIL	1
31	9828086	RETAINER O-RING	1
32	9828087	SOCKET RETAINER	1
33	9828088	ANVIL BUSHING	1
34	9828089	O-RING	1
35	9828090	SCREW	4
36	9444-00202E	HAMMER HOUSING	1
37	9828092	SPRING WASHER	8
38	9828093	SCREW	4
39	9828094	TRIGGER RETAINER	1
40	9828095	SCREW	2

Limited Warranty

Universal Tool warrants its tools to be free from defects in material and workmanship for one year from the date of purchase. This warranty does not apply to tools which have been abused, misused, modified or repaired by someone other than Universal Tool or its authorized service centers. If a Universal Tool proves defective in material of workmanship within one year after purchase, return it to any authorized service center or to Universal Tool, freight prepaid. Please enclose your name, address and adequate proof of purchase date with a brief description of the defect. Universal Tool will, at its option, repair or replace defective tools, free of charge. Repairs or replacements are warranted as described above for the remainder of the warranty period. Universal Tool's sole liability and your exclusive remedy under this warranty is limited to repair or replacement of the defective tool. There are no other warranties expressed or implied and Universal Tool shall not be liable for incidental, consequential or special damages, or any other damages, costs or expense of repair or replacement as described above.