

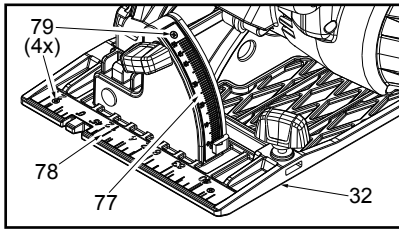

SERVICE PARTS LIST

**BULLETIN NO.
54-40-2660**

SPECIFY CATALOG NO. AND SERIAL NO. WHEN ORDERING PARTS		REVISED BULLETIN	DATE
Cordless M18 FUEL™ 7-1/4" Circular Saw			Jan. 2019
CATALOG NO. 2731-20	STARTING SERIAL NO. F95A	WIRING INSTRUCTION See Page Four	



EXAMPLE:
Component Parts (Small #) Are Included
When Ordering The Assembly (Large #).

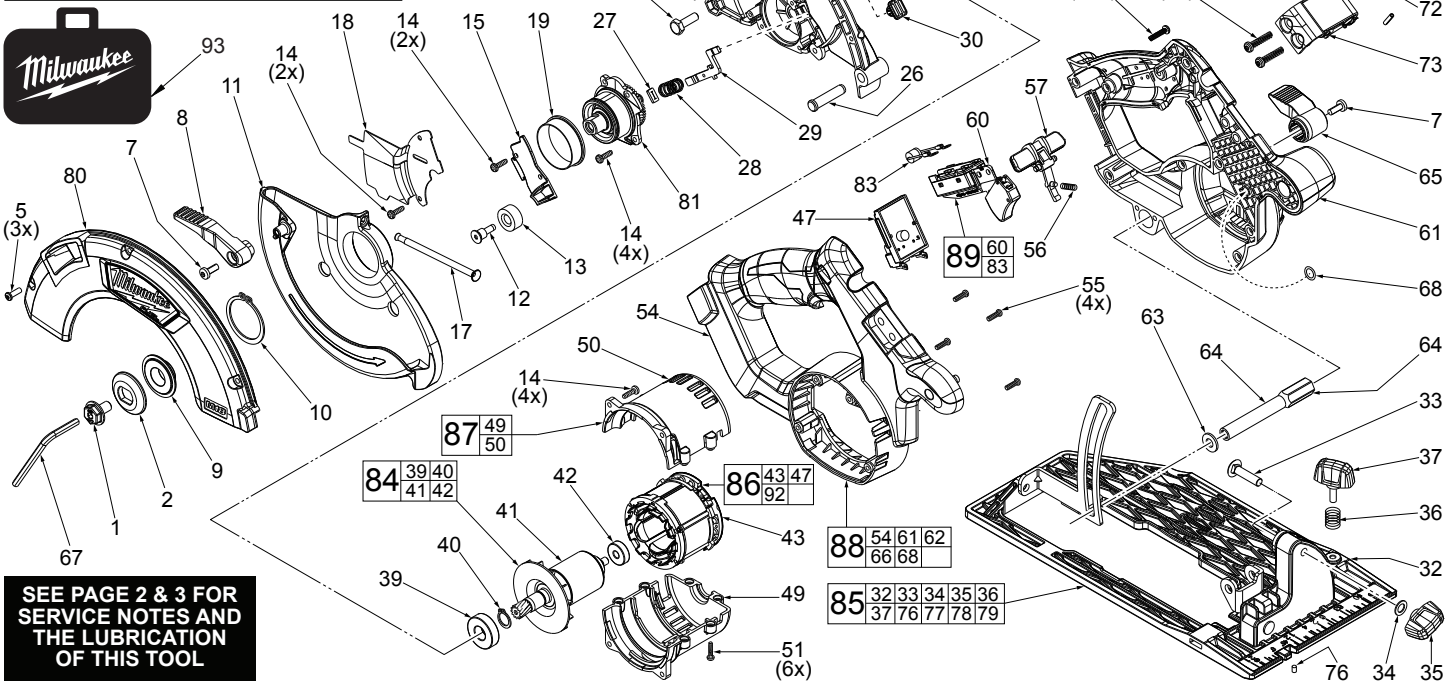
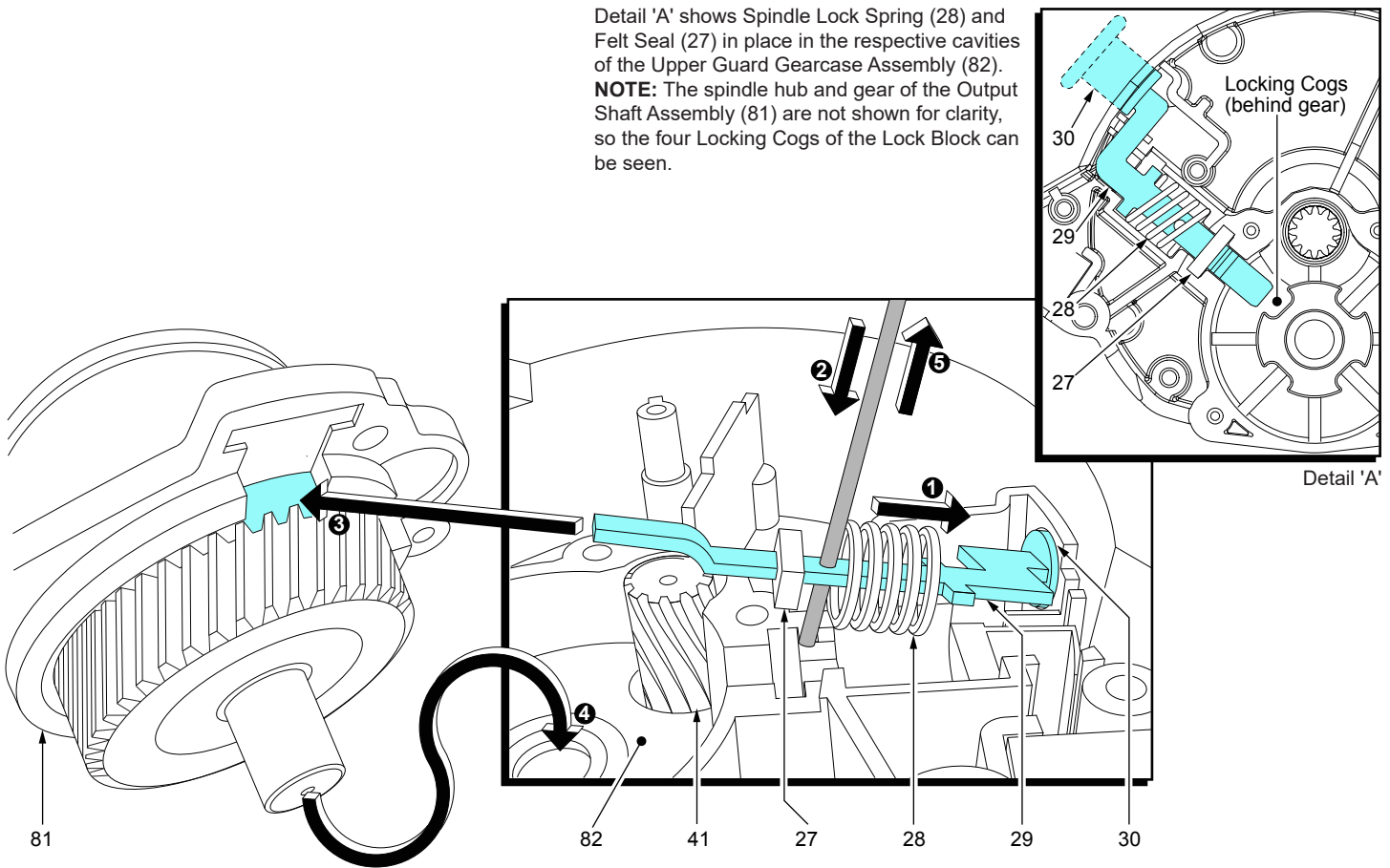

FIG. PART NO.	DESCRIPTION OF PART	NO. REQ.	FIG. PART NO.	DESCRIPTION OF PART	NO. REQ.
1	06-75-1012 Blade Screw	1	54	31-44-0983 Housing Support - Right Housing Halve	1
2	43-34-0795 Outer Flange	1	55	05-88-5380 M3.5 x 12mm T-10 Screw	4
5	05-78-5316 M4 x 14mm Pan Hd. Taptite T-20 Screw	3	56	40-50-1760 Switch Lock-Out Spring	1
7	06-82-5314 10-24 x 1/2" Pan Hd. Taptite T-25 Screw	2	57	42-42-0345 Switch Lock-Out Button	1
8	44-10-1008 Lower Guard Lever	1	60	23-66-2635 Switch with Screws	1
9	43-34-0790 Inner Flange	1	61	31-44-0986 Housing Cover - Left Housing Halve	1
10	34-60-0860 Retaining Ring	1	62	06-82-7470 6-19 x 11/16" Pan Hd. Plastite T-15 Screw	10
11	28-41-0101 Lower Guard	1	63	45-88-1515 Washer	1
12	45-04-0485 10-32 x 13/16" Bumper Screw	1	64	45-08-0395 Depth Shaft	1
13	42-38-0222 Rubber Bumper	1	65	44-10-0018 Depth Lever	1
14	06-82-5285 6-32 x 1/2" Pan Hd. Taptite T-15 Screw	12	66	12-20-0041 Service Nameplate (Not Shown)	1
15	31-15-0265 Spindle/LED Cover	1	67	49-96-0600 Hex Key	1
16	22-06-2732 LED Assembly (Not Shown, see page 4)	1	68	34-40-4480 O-Ring	1
17	40-50-0045 Lower Guard Spring	1	69	43-74-0065 Saw Hook Bar	1
18	44-66-0398 Retaining Plate	1	70	44-60-0585 Saw Hook Pin	2
19	45-14-0015 Plastic Sleeve	1	71	45-22-1005 Detent Sleeve	1
25	06-75-5860 1/4-20 x 3/4" Hex Hd. Screw	1	72	40-50-0985 Saw Hook Spring	1
26	44-60-0741 Pivot Pin	1	73	43-76-0035 Saw Hook Housing	1
27	45-06-0720 Felt Seal	1	74	06-82-0052 M6 x 2.69 x 32mm T-25 PT Screw	2
28	40-50-8046 Spindle Lock Spring	1	75	22-56-0150 Wire Connector (Not Shown, see page 4)	1
29	44-20-0653 Spindle Lock Plate	1	76	06-83-1600 Set Screw	1
30	42-42-1030 Spindle Lock Button	1	77	31-51-0137 Bevel Scale	1
32	Shoe	1	78	31-51-0132 Front Scale	1
33	06-10-0110 M6 x 28mm Carriage Bolt	1	79	06-81-0015 M2.5 x 3.175 Phillips Screw	4
34	45-88-1560 Washer	1	80	28-20-0027 Upper Guard Cover Assembly w/Logo Plate	1
35	43-98-0705 Bevel Adjustment Knob	1	81	38-50-0160 Output Shaft Assembly	1
36	40-50-0650 Rip Fence Spring	1	82	28-14-0172 Upper Guard Gearcase Assy. w/Bushing	1
37	43-98-0605 Rip Fence Knob	1	83	23-38-2840 Diode Assembly with Terminals	1
38	34-40-0360 O-Ring	1	84	23-40-7115 Rotor Assembly	1
39	02-04-0795 Ball Bearing	1	85	14-74-0505 Shoe Assembly	1
40	34-60-0610 Retaining Ring	1	86	23-58-7115 Stator / Electronics Assembly	1
41	Rotor	1	87	23-16-0005 Motor Insulator Assembly	1
42	02-04-5382 Ball Bearing	1	88	14-38-0020 Housing Assembly	1
43	Stator with PCBA	1	89	23-66-2639 Switch/Diode Assembly with Switch Screws	1
47	Battery Connector Block	1	91	49-22-2731 Rip Fence (Not Shown)	1
49	23-16-0090 Motor Insulator - Top	1	92	Mico Switch (Not Shown)	1
50	23-16-0095 Motor Insulator - Bottom	1	93	48-55-3500 Contractors Bag	1
51	06-82-1080 M3.0 x 14mm Pan Hd. T-10 ST Screw	6			
52	23-94-2731 High Voltage Wire with Terminal (See page 4)	1			
53	10-20-0359 Warning Label (Not Shown)	1			

Detail 'A' shows Spindle Lock Spring (28) and Felt Seal (27) in place in the respective cavities of the Upper Guard Gearcase Assembly (82).
NOTE: The spindle hub and gear of the Output Shaft Assembly (81) are not shown for clarity, so the four Locking Cogs of the Lock Block can be seen.



**ASSEMBLING OUTPUT SHAFT ASSEMBLY (81)
 INTO UPPER GUARD GEARCASE ASSEMBLY (82)**

To prevent damage to the Felt Seal (27) it is recommended to temporarily remove the felt seal until steps 1 and 2 are completed.

1. With the use of both hands, compress the Spindle Lock Spring (28) back on the Spindle Lock Plate (29) past the small hole on the plate.
2. While holding the spring back with one hand, quickly insert a thin metal instrument into the small hole on the plate. The metal instrument should capture the entire spring (all coils should be behind that tool).

With the spindle lock spring trapped behind the small hole on the spindle lock plate, slide the felt seal back onto the spindle lock plate. Position the felt seal above the corresponding cavity in the Upper Guard Gearcase (82).

3. Insert the open end of the spindle lock plate (29) into the opening of the Output Shaft Assembly (81) behind the gear, as shown.

4. Insert the bearing shaft portion of the output shaft assembly into the needle bearing of the upper guard gearcase assembly. Carefully wiggle the entire output shaft assembly until the gearing of the output shaft assembly engages with the pinion gearing of the Rotor (41) and the output shaft assembly slides into place.

Secure the output shaft assembly to the upper guard gearcase assembly with the use of four screws (14), not shown. It is recommended to alternate the tightening of the screws.

5. Remove the thin metal instrument. Check for the proper functioning of the spindle locking mechanism. Rotate the spindle shaft and depress the Spindle Lock Button (30) at the same time. The spindle lock plate should drop into one of four cogs that lock the spindle. Spindle lock mechanism must return briskly when released from engagement in the lock block cog.

LUBRICATION

Type 'Y' Grease, No. 49-08-5270

Apply 3.0 grams (.10 oz) of 'Y' Grease to the gear bore in Upper Guard Gearcase (82). The grease should be directed toward the pinion end of the rotor (41).

When servicing, remove 90-95% of the existing grease prior to installing Type 'Y'. Original grease may be similar in color but not compatible with 'Y'.

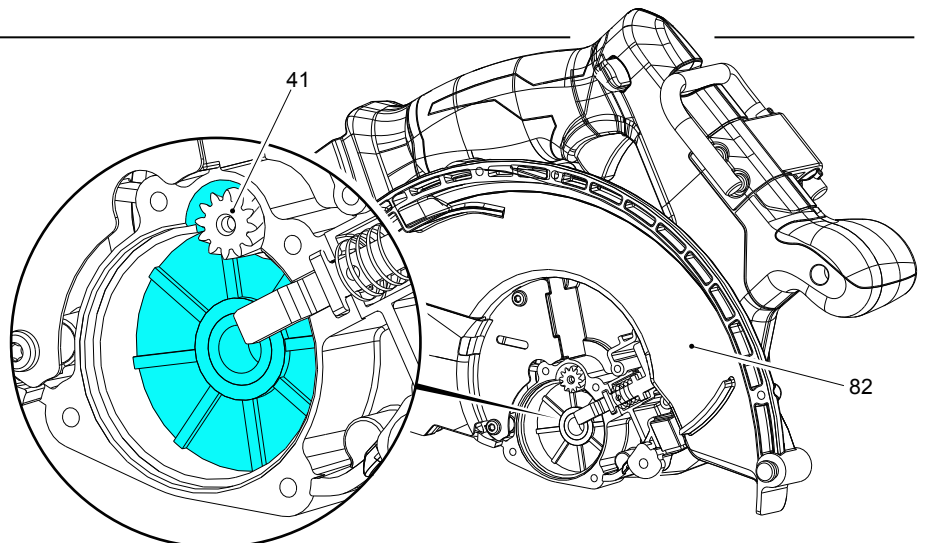

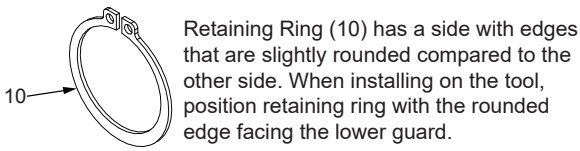

Orient Ball Bearing (39) so that the seal faces the fan of the Rotor (41) and the open side faces the gearcase.

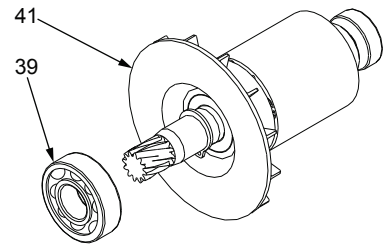

IMPORTANT:

- **Strong magnetic force.** Care must be taken when installing the Rotor (41) into the Stator Assembly (43). Do not allow rotor bearing or balancing bushing to hit PCBA on the back end of the stator. This could cause damage to the PCBA. See figure 1.

- Insert the rotor/stator assembly into pinion bore of the Upper Guard Gearcase Assembly (82). Carefully wiggle and push the rotor/stator until the ball bearing in front of the fan is fully seated in the bearing bore of the gearcase. See figure 2.

NOTE: As an aid to installation, apply a light film of lubricant to the bearing bore of the gearcase before assembling the rotor/stator.

- Place the Bottom and Top Motor Insulators (50,49) in place around the rotor/stator assembly. Secure the halves with six Screws (51). A light tapping on the back of the assembled insulator halves may be necessary to completely seat the insulator halves onto the upper guard gearcase. Fasten the insulator halves to the gearcase with four Screws (14). See figure 3. When tightening, alternate the screws to assure square, even pressure.

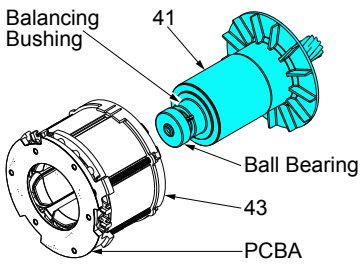

Figure 1

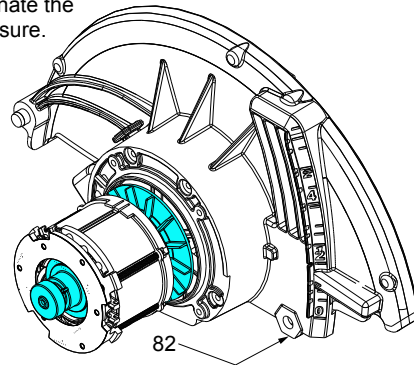

Figure 2

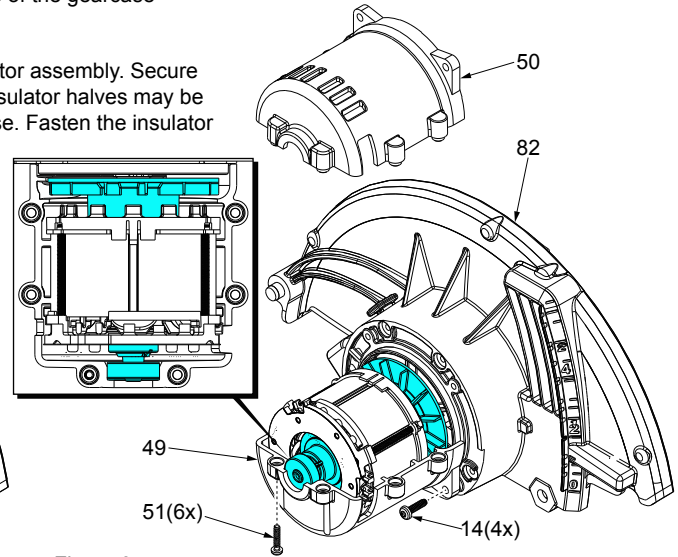
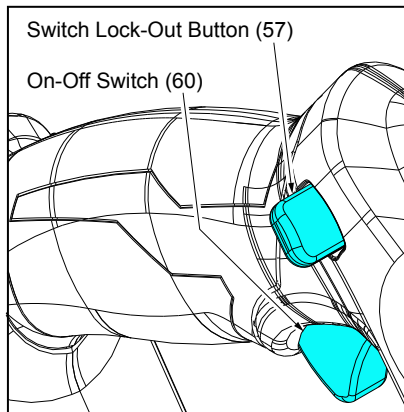

Figure 3



Functionally check Switch Lock-Out (57) by attempting to turn on tool by applying a reasonable amount of force, up to 8 lbs., to the switch trigger (60). The tool must not turn on.

Release trigger. Actuate the lock-out lever and apply a reasonable amount of force to the switch trigger. The tool must turn on. While the trigger is still in the "ON" position, release the lock-out. Release the trigger. The tool must stop and the lock-out lever must again prevent the actuation of the Switch.

Repeat the switch check two more times.

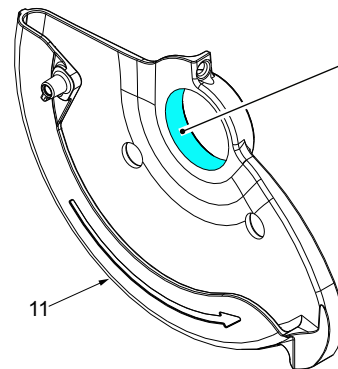

NOTE: Do not use grease on inside diameter of Lower Guard (11). Apply a dry PTFE spray lubricant or something similar.

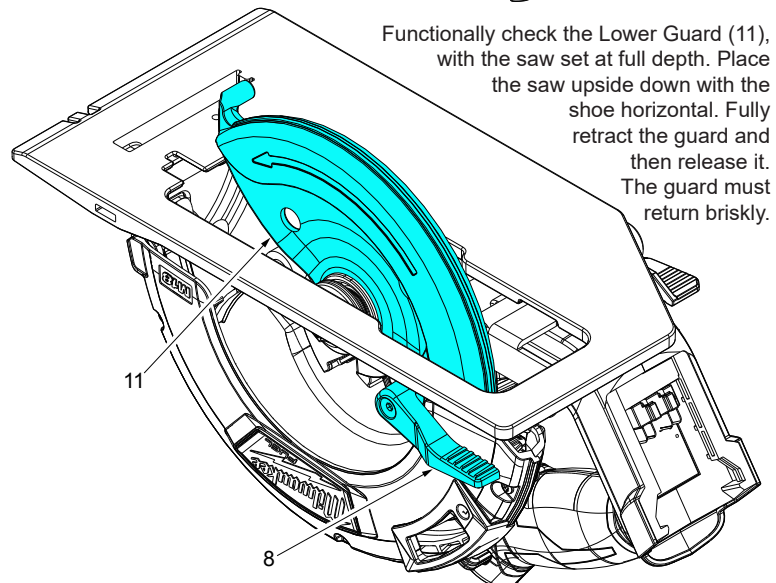
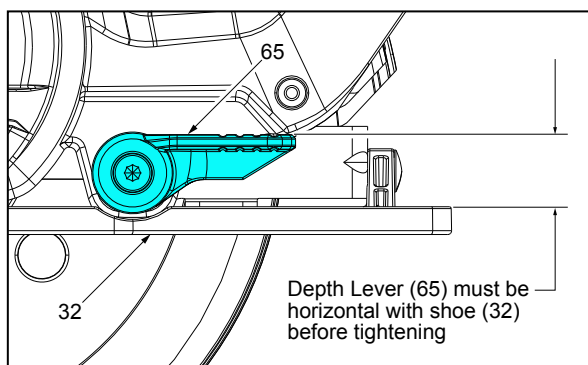

WIRING OF THE ON-OFF SWITCH

- Orient the diode with the grey stripe to the right as shown. Place ring terminals of diode assembly onto the switch prior to installing red wires #1 and white wire #2.
- Place ring terminal of red wire #1 (from the top PCBA position) at the bottom left position of switch over diode terminal. Be sure wire is routed over the diode assembly.
- Place ring terminal of white wire #2 (from the battery connector block) at the bottom right position of the switch over diode terminal. Be sure wire is routed over the diode assembly.
- Secure diode assembly and wires #1 and #2 with switch screws.
- Route white wire #3 (from the battery connector block) between red wires #1 and #2, and under the diode assembly, to the upper right position of the switch. Secure the ring terminal with a switch screw, as shown.
- Route yellow wire #4 (from the battery connector block) between red wires #1 and #2, and under the diode assembly, to the upper left position of the switch. Secure the ring terminal with a switch screw, as shown.

● = WIRE TRAPS or GUIDES

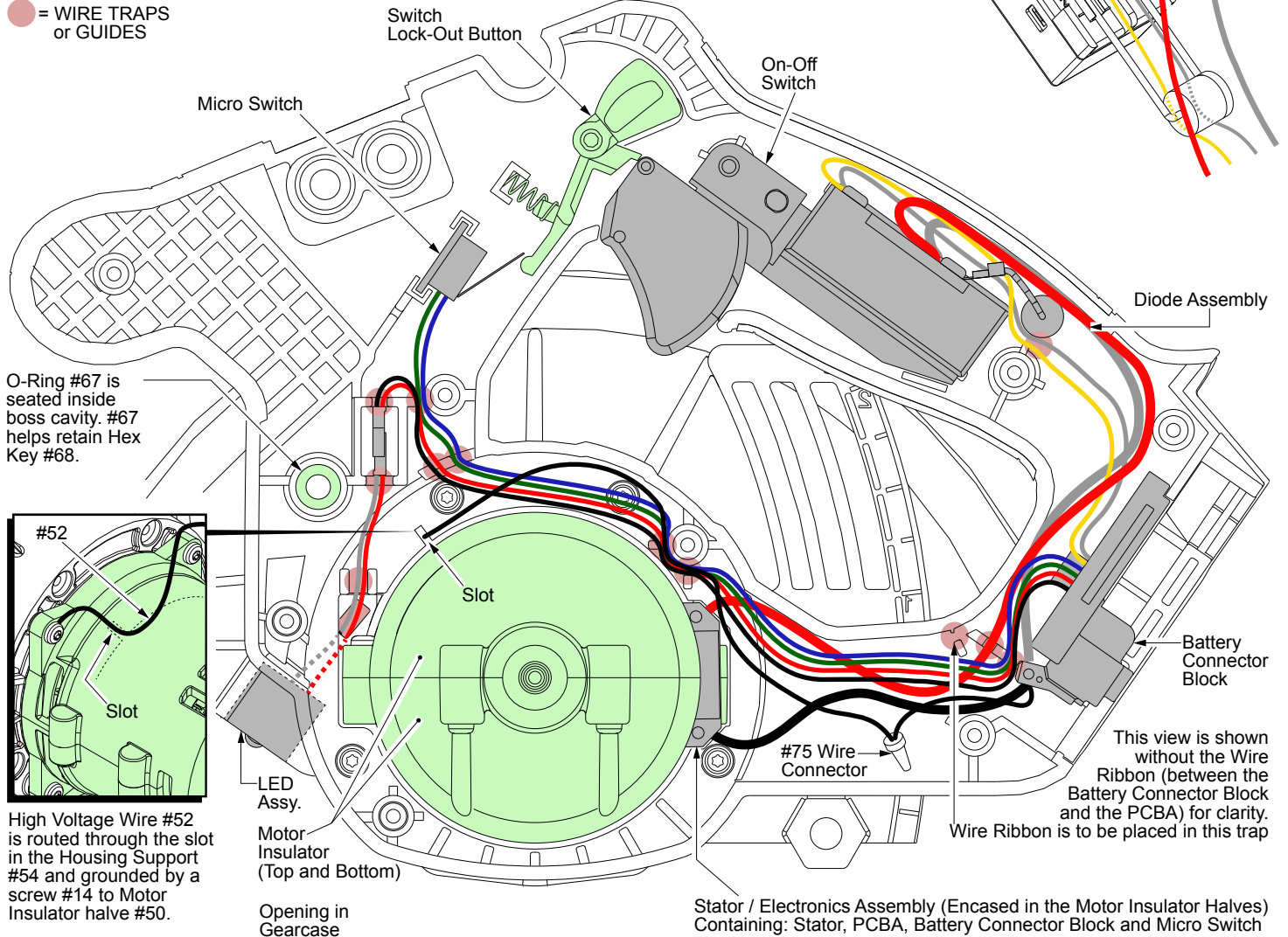

Stator / Electronics Assembly (Encased in the Motor Insulator Halves) Containing: Stator, PCBA, Battery Connector Block and Micro Switch

Figure 1: Shown without the Spindle Lock Assembly for clarity.

- Insert the LED Assembly into cavity of Upper Guard Gearcase as shown.
- Route male connector and wires through the openings in the Gearcase and Housing Support.
- Be sure that LED wires are in Gearcase trap and pull taut.

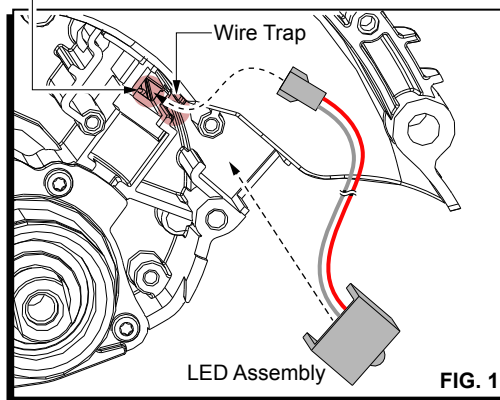

Figure 2:

- Connect the male connector of the LED Assembly with the Female connector from Battery Connector Block.

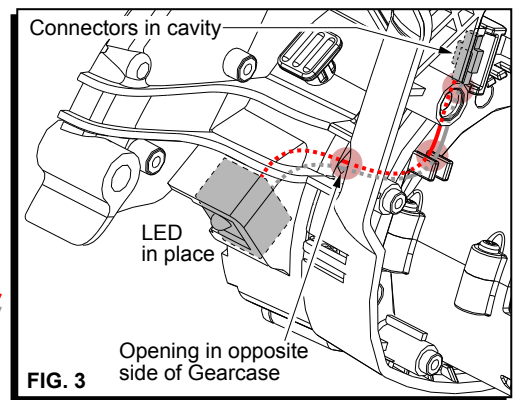
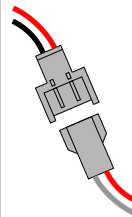

Figure 3:

- Place the joined connectors in the Housing Support cavity and route all wires in the appropriate wire traps as shown in main illustration.