

**MODEL UT 8833R
3/8" Drill**

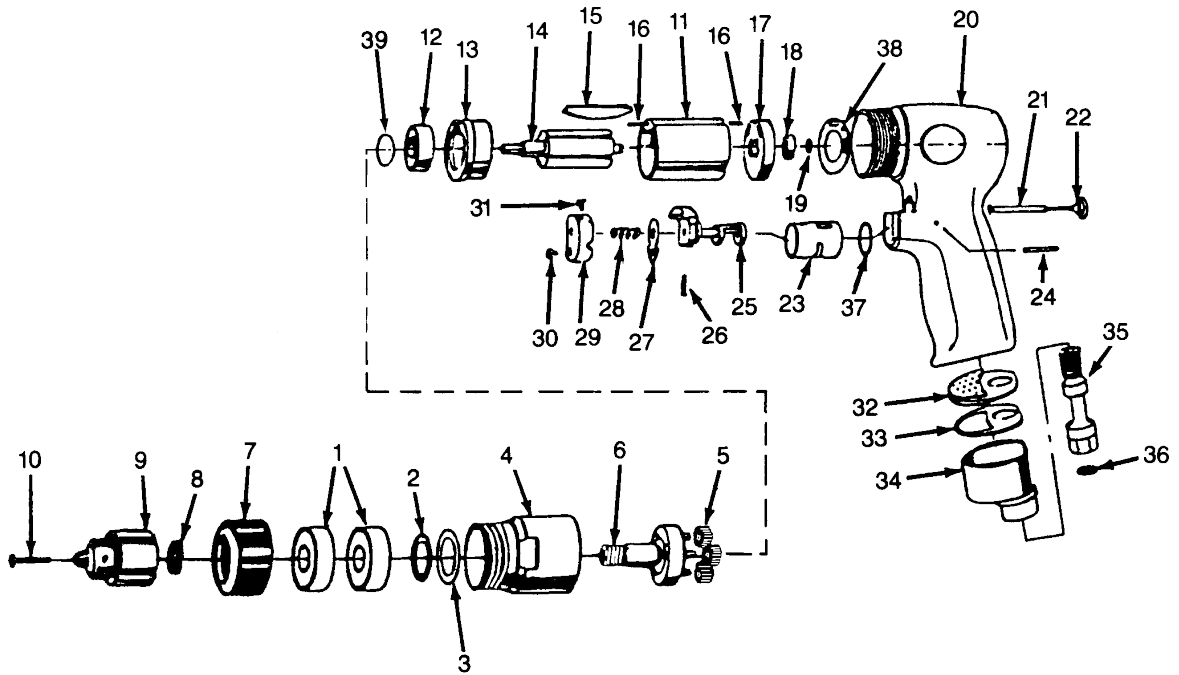

Parts List

Ref. No.	Description	Part No.
1	Ball bearing (2)	81000894
2	•Phenolic washer	8730231
3	•Spacer	8730232
4	Gear housing - 42T	8730233
5	Planet gear (3)	8730235
6	Planet carrier	8730288
7	Bearing cap	8730230
8	Chuck spacer	8730229
9	3/8" Drill chuck & key	5950
10	Chuck screw	8900100
11	Cylinder	8730239
12	Ball bearing	81011898
13	Front plate	8730236
14	Rotor - 6T	8730237
15	•Rotor blades (4)	8729709
16	Pin (3)	8729707
17	Rear plate	8730240
18	Ball bearing	8729012
19	Retaining ring	8729180
20	Motor housing	8900118

Ref. No.	Description	Part No.
21	Throttle valve	8730246
22	•O-ring	81008173
23	Valve bush	8900117
24	Pin	8900120
25	Reverse valve	8730244
26	Spring assembly	8730245
27	Detent plate	8730243
28	Spring	8730242
29	Trigger	8730241
30	Trigger screw	8730255
31	Screw	81015856
32	Muffler	8730248
33	Gasket	8730249
34	Muffler cover	8730250
35	Hose adapter	8730251
36	Screen	81005726
37	•O-ring	8900119
38	•Motor gasket	8732318
39	•Spacer	8900459
(•)	Items recommended for tune-up	