

## MODEL UT 8750 4 1/2" Angle Grinder

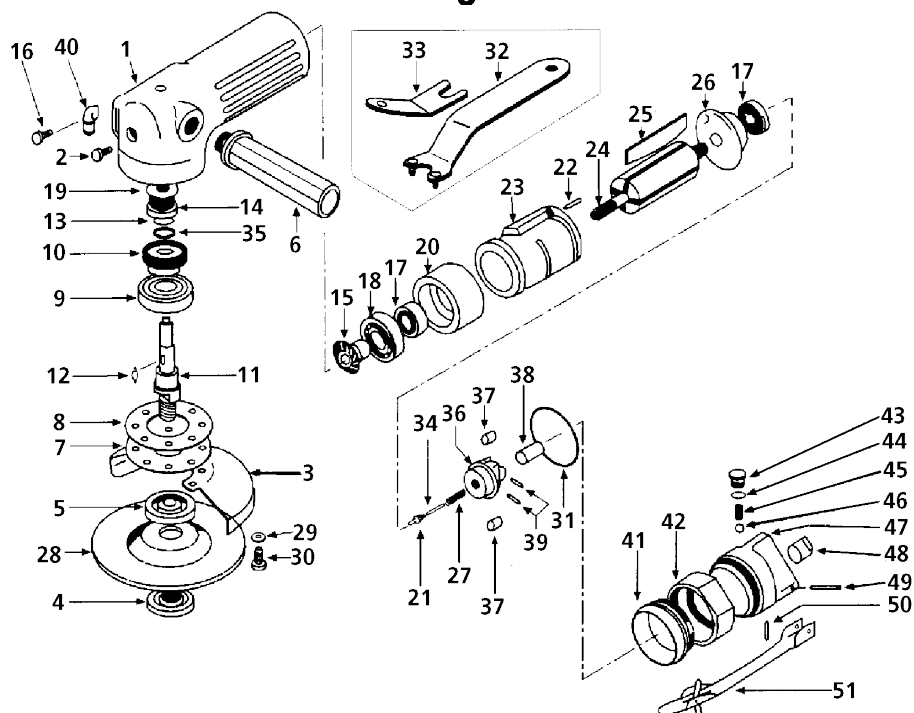

### Parts List

Ref. No.	Description	Part No.
1	Body	8732343
2	Screw	8732344
3	Disc cover	8900871
4	Disc nut	8901039
5	Disc receiver	8901038
6	Grip	8732348
7	Retainer	8732349
8	Gasket	8732350
9	Bearing	8732351
10	Bevel gear	8900868
11	Gear shaft	8901037
12	Key	8732354
13	Retaining ring	8732355
14	Bearing	8732356
15	Pinion	8900874
16	Screw (2)	8732358
17	Bearing (2)	8732359
18	Bearing	8732360
19	Spacer	8732361
20	Front plate	8730087
21	Adjust nut	8732363
22	Spring pin	8732364
23	Cylinder	8729229
24	Rotor	8732366
25	Rotor blade (4)	8729230
26	Rear plate	8729231

Ref. No.	Description	Part No.
27	Spring	8732370
28	•4-1/2" Disc Type 27	
29	Washer (4)	8732378
30	Screw (4)	8732379
31	O-ring	8732381
32	Disc spanner	8901040
33	Stop spanner	8732383
34	Adjust screw	8732384
35	Wave washer	8732385
36	Governor	8732386
37	Pendulum (6)	8732387
38	Plunger	8732388
39	Spring pin (2)	8732389
40	Exhaust cover	8732390
41	Lock ring	8732392
42	Coupling nut	8732393
43	Valve nut	8732394
44	O-ring	8732395
45	Valve spring	8732396
46	Valve ball	8732397
47	Valve housing	8732398
48	Bushing	8732399
49	Pin	8732400
50	Valve pin	8732401
51	Throttle lever	8732402
(•)	Not included.	