

CP760 Series Air Sander

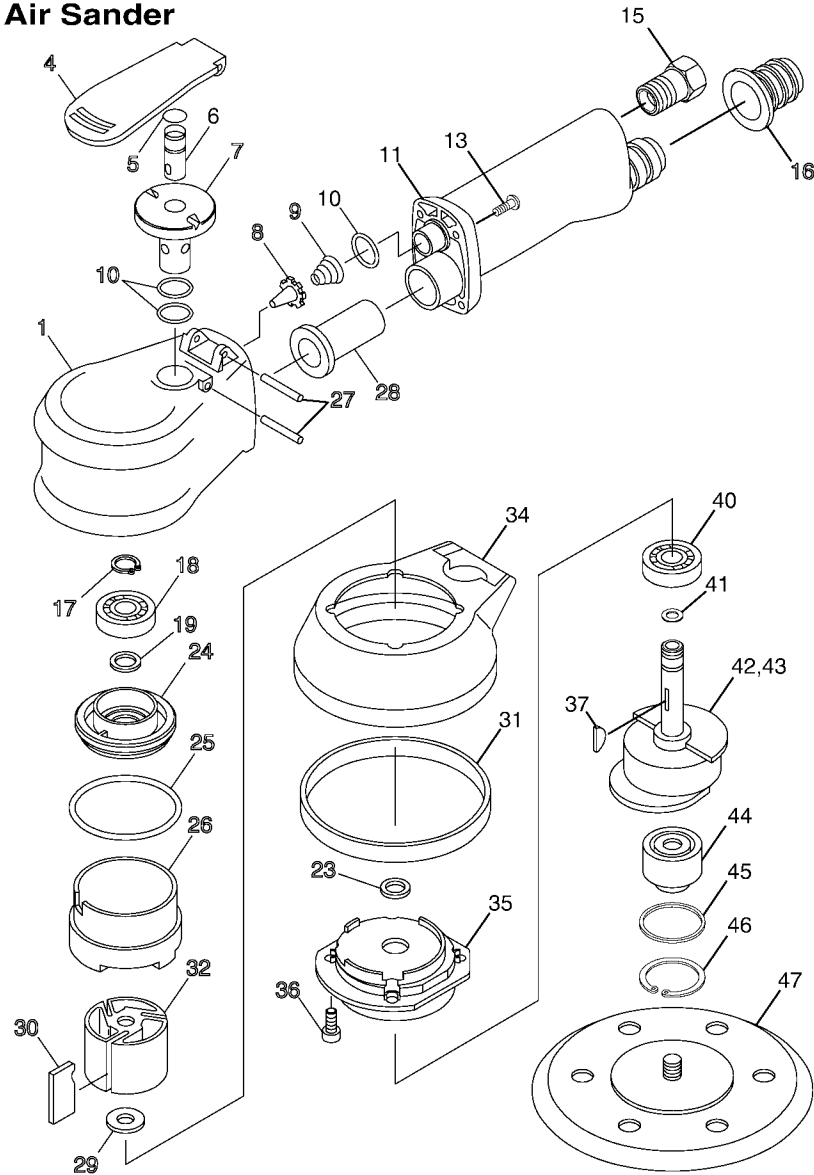

Index No.	Part No.	Description	No. Req'd.
1	CA147388	Housing- Motor	1
4	CA147389	Lever-Throttle	1
5	CA147390	O-Ring (4.1 x 1.6)	1
6	CA147391	Stem-Throttle Valve	1
7	CA147392	Valve-Throttle	1
8	CA147393	Seat-Throttle Valve	1
9	CA147394	Spring	1
10	CA147395	O-Ring (14.1 x 1.6)	3
11	CA147396	Handle (long) (CP760)	1
	CA148114	Handle-Palm Grip (CP760P)	1
13	CA147397	Screw (M16)	1
15	CA147398	Bushing-Air Inlet (1/4" NPT)	1
16	CA147399	Coupling-Vacuum Hose	1
17	CA143187	Ring-Retaining	1
18	SO25055	Bearing-Ball (6200 2Z)	1
19	CA147400	Spacer-Bearing	1
23	CA147401	Spacer-Bearing	1
24	CA147402	Plate-Upper End	1
25	CA147403	O-Ring (52 mm x 5 mm)	1
26	CA147404	Liner	2
27	CA136794	Pin-roll (3 mm x 30 mm)	1
28	CA147405	Insert-Venturi	1
29	CA147406	Shim-Spacer (0.0038 mm x 14.9 mm)	1
30	C143183	Set-Rotor Blade (3)	1
31	C143154	Brush-Complete	1
32	C143184	Rotor	1
34	CA147407	Shroud-Vacuum	1
35	CA147408	Plate-Lower End	1
36	CA127936	Screw-Soc. HD Cap (M5 x 20 mm)	4
37	C143180	Key-Woodruff	1
40	CA147409	Bearing-Ball (6002 2Z)	1
41	CA147410	O-Ring (6.1 x 1.6)	1
42	CA147425	Hub-Orbital (CP760)	1
43	CA147411	Hub-Orbital (CP760P)	1
44	CA147412	Bearing-Ball (6201 RSR)	1
45	CA147413	Washer-Waved (EPL24)	1
46	CA147414	Circlip-Internal (7000-032PF)	1
47	CA142413	Pad-Sanding Vacuum (6 in. dia.)	1

