



# SERVICE PARTS LIST

**BULLETIN NO.**  
PN0013244

SPECIFY CATALOG NO. AND SERIAL NO. WHEN ORDERING PARTS		REVISED BULLETIN	DATE
<b>M12 FUEL™ 1/2" Extended Reach Ratchet</b>			May 2026
CATALOG NO. 3055-20	SERIAL NO. R91A	WIRING INSTRUCTION See Page 3-4	
NAMEPLATE SPECIFICATIONS:		INPUT: 12 V = n <sub>0</sub> 0 - 300 min <sup>-1</sup> (RPM)	

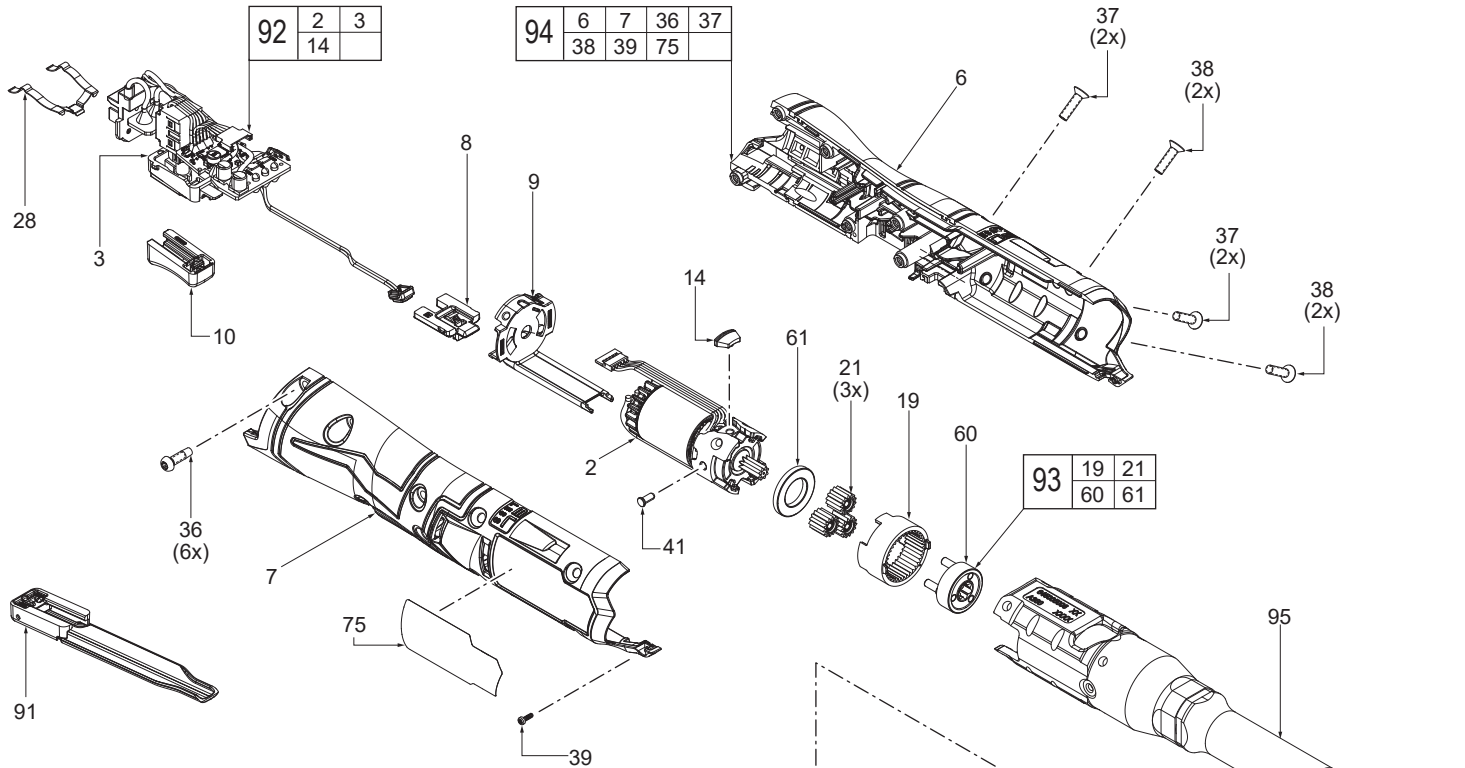

FIG.	PART NO.	DESCRIPTION OF PART	NO. REQ.
2	-----	Motor	(1)
3	-----	PCBA	(1)
6	-----	Housing Support	(1)
7	-----	Housing Cover	(1)
8	45-72-0027	Trigger Lock Out	(1)
9	43-84-0037	Yoke Housing Insert	(1)
10	30-16-2002	Trigger Cap	(1)
12	-----	Anvil Washer	(1)
14	45-06-0056	Stator Bracket Seal	(1)
19	-----	Ring Gear	(1)
21	-----	Planet Gear	(3)
23	45-08-0103	Crankshaft	(1)
26	-----	Anvil	(1)
27	-----	C-Ring	(1)
28	42-70-0480	Spring Clip	(1)
29	45-88-2001	Washer	(1)
36	05-88-5375	M4 x 13.5mm T-20 Cap Head Screw	(6)
37	05-81-0594	M4 x 14mm T-20 Flat Head Screw	(4)
38	05-88-0038	M4 x 15mm T-20 Flat Head Screw	(4)
39	06-82-0243	M2 x 6mm T-6 Pan Head Screw	(1)
41	44-60-0890	Drive Pin	(1)
51	42-40-0041	Cylinder Bushing	(1)
54	45-98-0103	Yoke	(1)
60	-----	Carrier with 3 Pins	(1)
61	-----	Planet Washer	(1)
75	12-20-1003	Service Nameplate	(1)
90	42-06-0133	1/2" Anvil Kit	(1)
91	31-92-0011	Paddle Assembly	(1)
92	23-30-0123	1/2" Motor and PCBA Assembly	(1)
93	14-29-2002	1/2" Gear Train Assembly	(1)
94	31-50-2001	Handle Kit	(1)
95	28-14-0127	1/2" Gearcase Assembly	(1)

**EXAMPLE:**  
Component Parts (Small #)  
Are Included When Ordering  
The Assembly (Large #).

**FIG. NOTES**  
75 A clean, dry surface is essential for proper performance for any adhesive system. The area intended for application of any adhesive label or nameplate must be prepared by cleaning with isopropyl alcohol. The solvent is to be applied with a clean, lint free applicator and the surface allowed to dry before applying the label or nameplate.

## ACCESSORIES

FIG.	PART NO.	DESCRIPTION OF PART	NO. REQ.
100	-----	1/2" Anvil	(1)
101	-----	Retaining Ring	(1)
102	-----	Trigger Cap #4	(1)
103	-----	Trigger Cap #2	(1)
104	-----	Trigger Cap #3	(1)
105	-----	Trigger Cap	(1)
106	-----	Extended Paddle Cap	(1)
107	-----	Trigger Paddle Pin	(1)
108	-----	Extended Paddle	(1)
151	49-16-3058	1/4" Ratchet Boot - (Not Shown)	(1)
152	49-16-3059	3/8" Ratchet Boot - (Not Shown)	(1)
153	49-16-3055	1/2" Ratchet Boot	(1)
154	49-06-3052	1/4" Low Profile Anvil Assy (Not Shown)	(1)
155	49-06-3053	3/8" Low Profile Anvil Assy (Not Shown)	(1)
156	49-06-3054	1/2" Low Profile Anvil Assy	(1)
157	49-16-3053MTC	Ratchet Trigger Kit	(1)

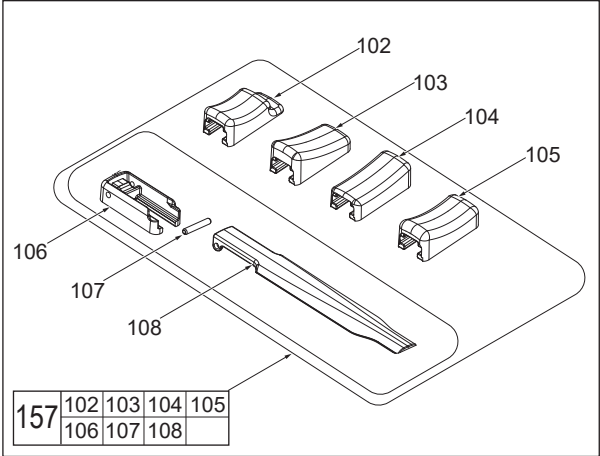
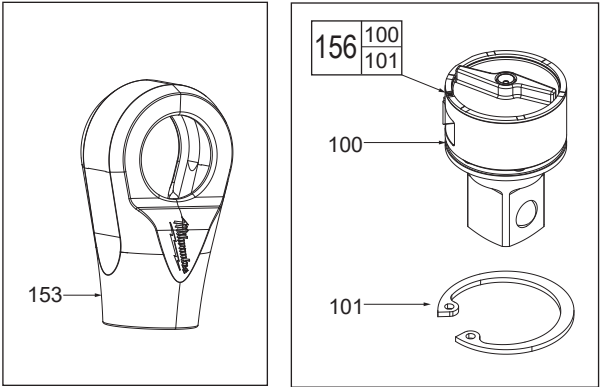

## HOUSING SCREWS - FASTENING ORDER

- FIG. 38
- FIG. 37
- FIG. 36
- FIG. 39

SCREW TORQUE SPECIFICATIONS				
FIG.	PART NO.	WHERE USED	SEAT TORQUE	
			kgf-cm	lb-in
36	05-88-5375	Housing Cover & Support	15±1.5	13±1.3
37	05-81-0594	Housing Cover & Support	15±1.5	13±1.3
38	05-88-0038	Housing Cover	13±1	11±0.9
39	06-82-0243	Housing Cover	1±0.2	0.9±0.2

### Housing Cover

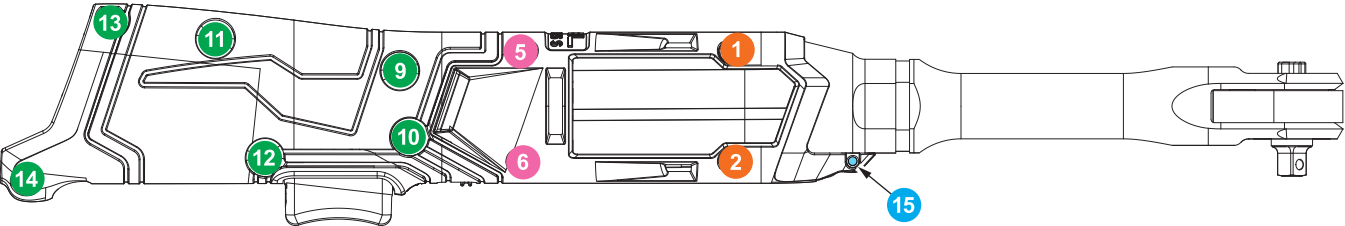

### Housing Support

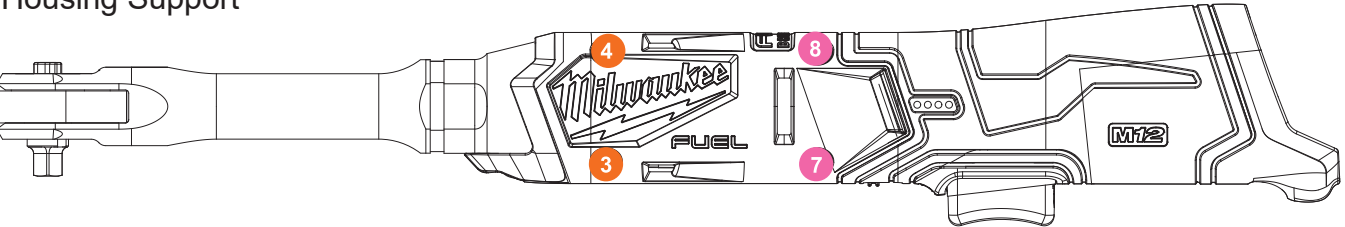

## WIRING INSTRUCTIONS

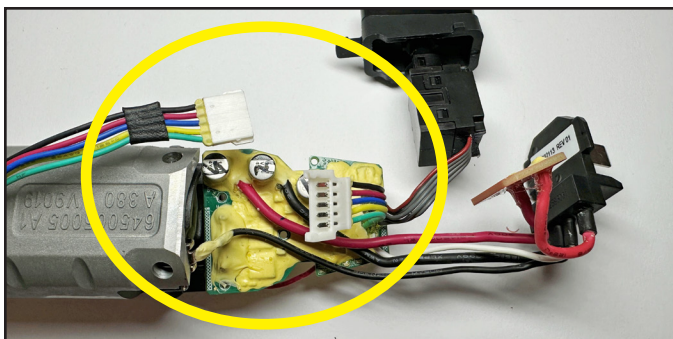

- 1) Take the connector and trigger and route over the indicated cables.



- 2) Align the LED so that it is centered with the gearcase slot.

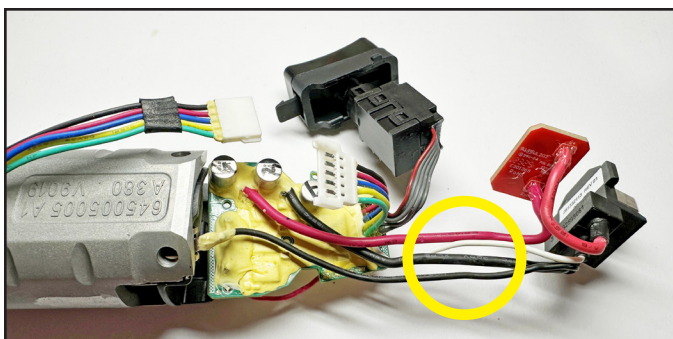

- 3) Take the PCBA and hold the white and red wire over the black wires.

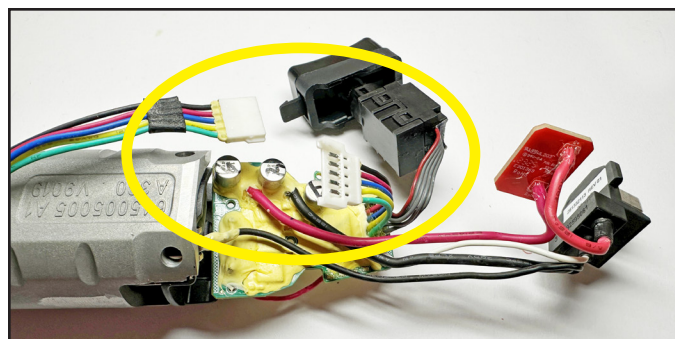

- 4) Check that the connector and trigger are on top of the previously ordered cables.

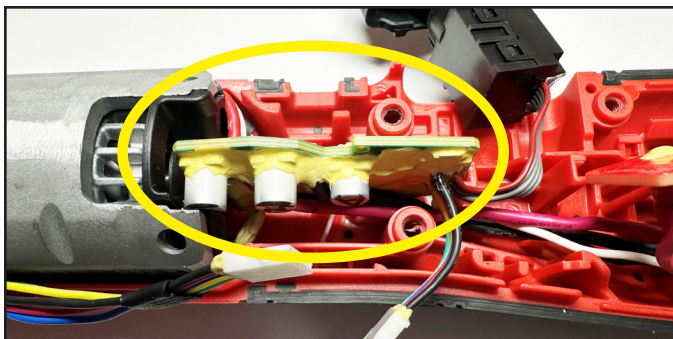

- 5) Holding the cables, place the PCBA into the slots, press until full seated. Previously ordered cables should be routed inside of slot.

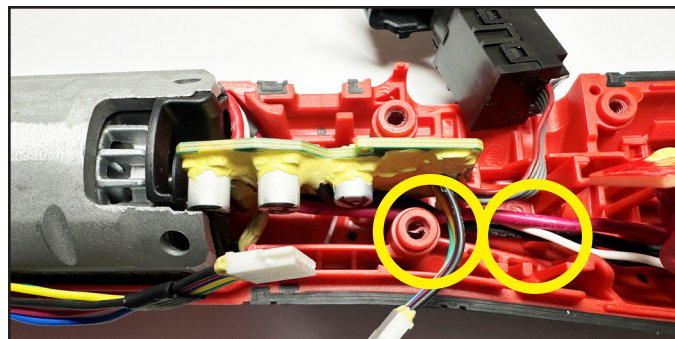

- 6) Check that the white and red wires are on top of the housing, while the black wires are on the bottom and the connector wire is wrapped around the outside of the screw boss.

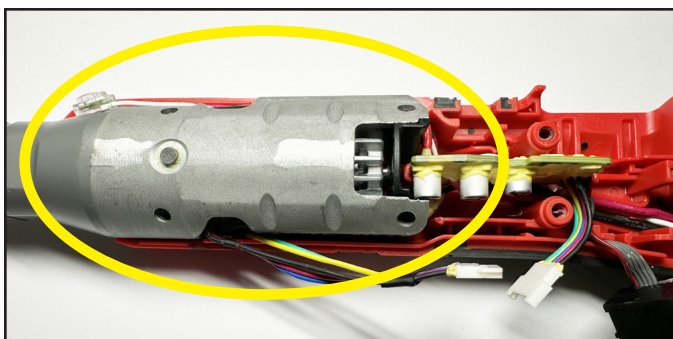

- 7) Push the gearcase sideways to the right to align the gearcase with the housing. Check that the LED slot is aligned to ensure proper assembly.



- 8) Place the LED into its slot, then route the LED wires so that the white wire is above the red wire in the housing.

## WIRING INSTRUCTIONS - CONTINUED

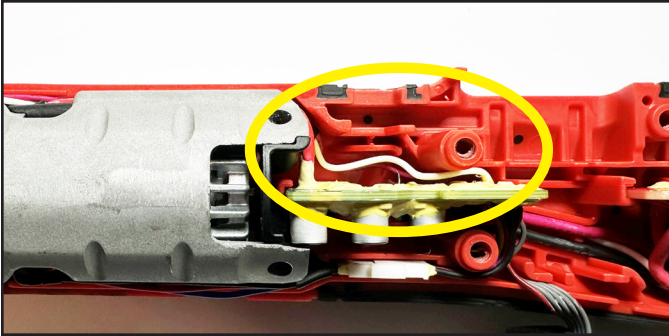

9) Route the LED wires into the indicated slot within the housing.

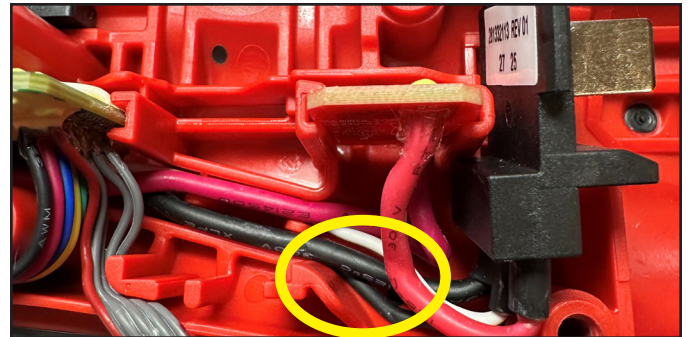

10) Route the thin black wire through the bottom slot in the housing.

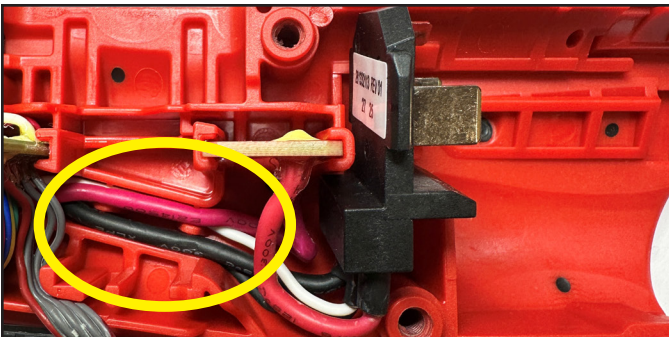

11) Route the thick black wire through the bottom slot in the housing over the thin black wire.

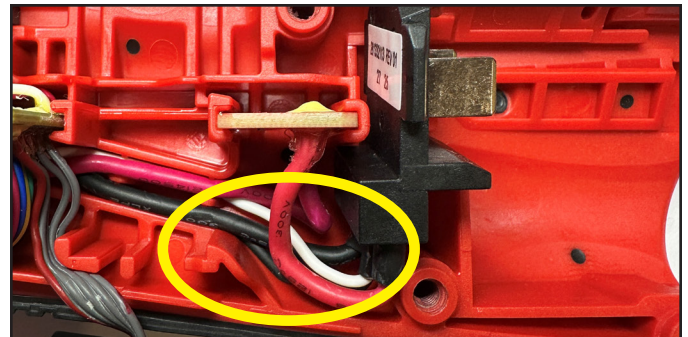

12) Route the white wire through the top slot in the housing.

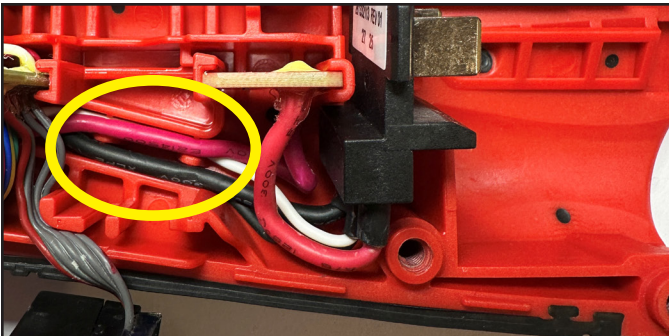

13) Route the red wire in top slot on top of white wire.

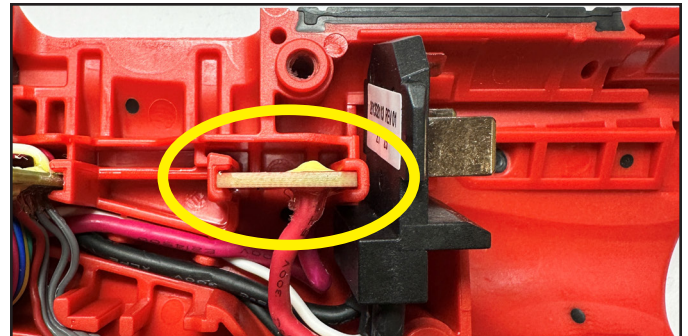

14) Install the HIT board into its slot.

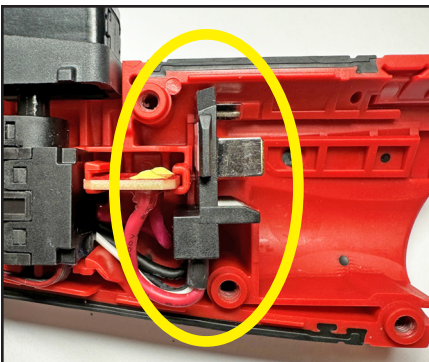

15) Install the Battery Terminal into the slot behind the HIT board.

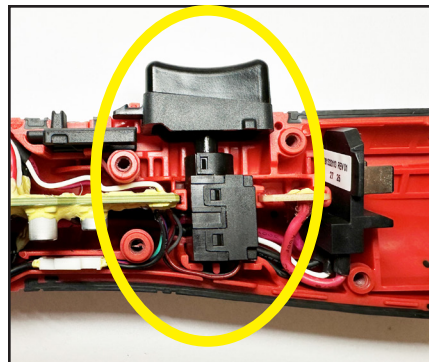

16) Install the trigger into the housing by routing wires through the slot at the bottom of housing.

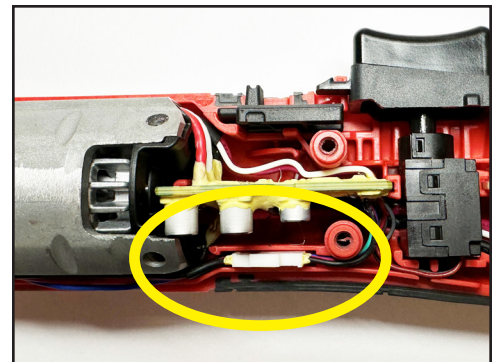

17) Connect and route hall sensor wires against gearcase. Connector should sit in slot at the bottom of housing.

# LUBRICATION INSTRUCTIONS

● **Type "J" Grease**  
No. 49-08-4220 (1 lb. can)

**NOTE:** When servicing, remove 90-95% of the existing grease prior to installing Type "J" grease. Original grease may be similar in color but not compatible with "J" grease.

Prior to reinstalling, clean gear assemblies with a clean, dry cloth. Lightly coat all individual parts highlighted here with "J" grease. Apply a greater amount of grease to all internal and external gear teeth. Internal components of the anvil assemblies should come from the factory pre-lubricated.

