



# SERVICE PARTS LIST

**BULLETIN NO.**  
**54-38-2350**

<b>SPECIFY CATALOG NO. AND SERIAL NO. WHEN ORDERING PARTS</b>		REVISED BULLETIN	DATE
<b>M18 FUEL™ Flat Head Braking Angle Grinder w/ Paddle Switch</b>			May 2022
<b>CATALOG NO.</b>	<b>2886-20</b>	<b>STARTING SERIAL NO.</b>	<b>L72A</b>
			<b>WIRING INSTRUCTION</b> <b>SEE PAGE 2</b>

**EXAMPLE:**  
Component Parts (Small #) Are Included  
When Ordering The Assembly (Large #).

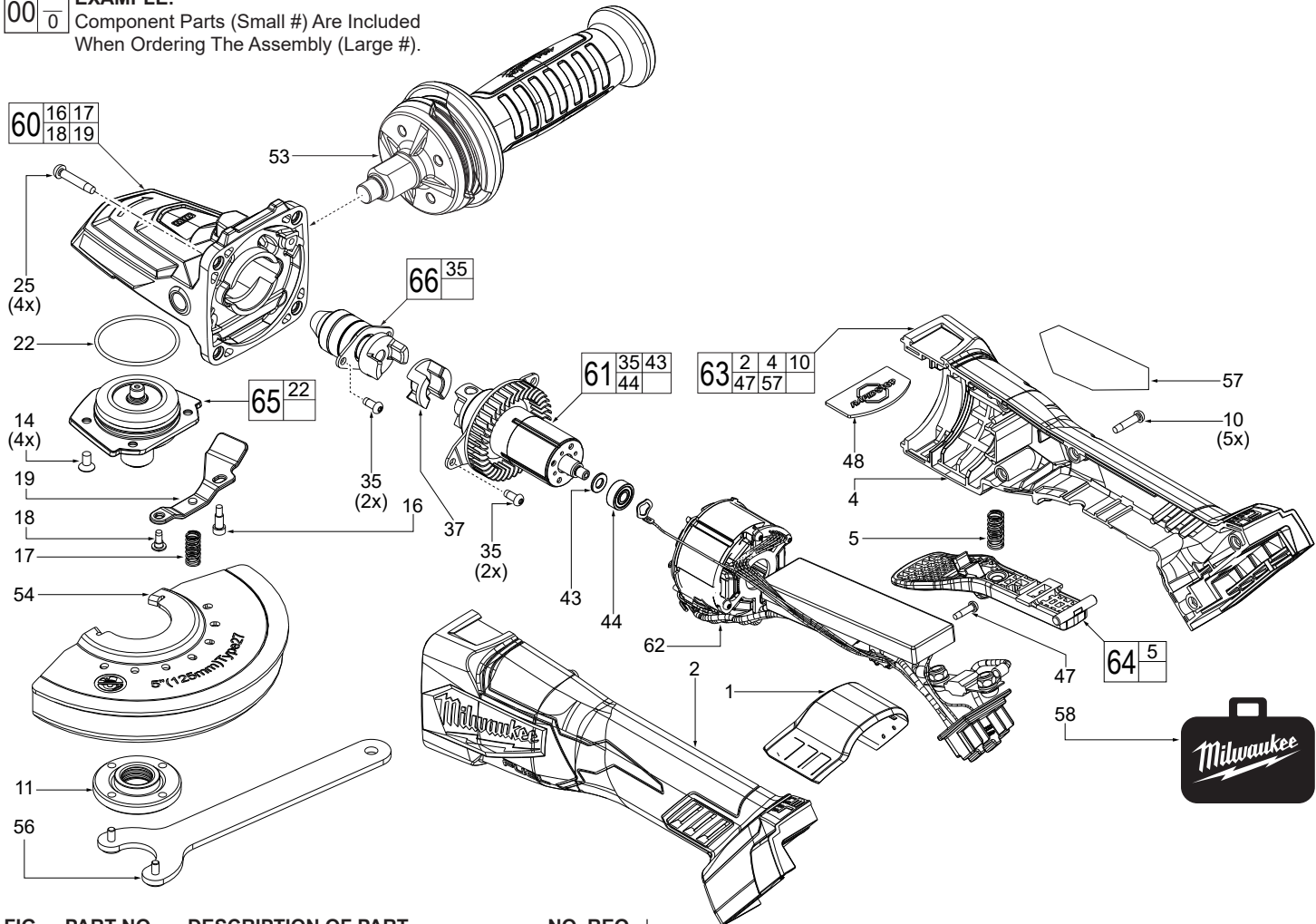
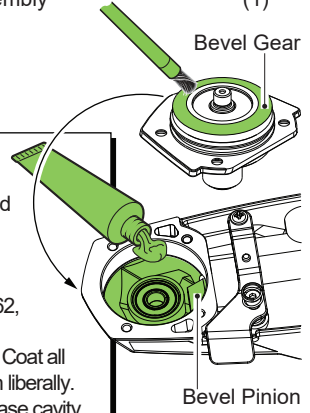

FIG.	PART NO.	DESCRIPTION OF PART	NO. REQ.
1	31-15-0103	Dust Cover	(1)
2	-----	Left Housing Halve-Support	(1)
4	-----	Right Housing Halve-Cover	(1)
5	40-50-0243	Spring	(1)
10	06-82-2025	M3.5 x 16mm Pan Hd. ST T-10 Screw	(5)
11	44-40-7100	5/8" Flange Nut	(1)
14	05-74-0302	M4 x 8mm Flat Hd. T-20 Macine Screw	(4)
16	05-74-0301	M3 x 12mm Cap Hd. Shoulder Scr. w/Hex	(1)
17	40-50-0456	Spring	(1)
18	45-04-0031	M3 x 8.5mm Pan Washer Hd. Phillips Screw	(1)
19	44-10-0137	Wheel Guard Locking Lever	(1)
22	34-40-0266	O-Ring	(1)
25	05-88-1255	M4 x 22mm Pan Hd. ST T-20 Screw	(4)
35	06-82-2660	M3.5 x 8mm Pan Hd. Taptite T-10 Screw	(4)
37	42-90-0024	Plastic Coupler	(1)
43	45-88-0241	Flat Washer	(1)
44	02-04-0111	Ball Bearing	(1)
47	06-82-1087	M3 x 12mm Pan Hd. ST T-10 Screw	(1)
48	43-84-0207	Rapid Stop Plate	(1)
53	14-34-0109	Side Handle Assembly	(1)
54	28-41-0106	5" Type 27 Wheel Guard Assembly	(1)
	28-41-0105	5" Type 1 Cutting Guard (Not Shown)	(1)
56	49-96-7215	Spanner Wrench	(1)
57	12-20-0368	Service Nameplate	(1)
58	50-55-3560	Contractor Bag	(1)
60	14-29-0097	Gearcase Assembly	(1)
61	16-01-0116	Rotor Assembly	(1)
62	14-20-0196	Electronic Assembly	(1)
63	14-38-0104	Housing Kit	(1)

FIG.	PART NO.	DESCRIPTION OF PART	NO. REQ.
64	31-92-0256	Paddle Trigger Assembly	(1)
65	28-53-0096	Spindle Hub Assembly	(1)
66	42-90-0068	Pinion/Coupler Assembly	(1)

**\*LUBRICATION NOTE:**  
When servicing the Gear Case Assembly, 90-95% of the old grease must be removed prior to new grease being added.

**FIG. LUBRICATION\***  
65,66 Type 'S2' Grease, No. 49-08-5262, 1.4 oz. / 40g tube.  
Apply 5g of 'S2' grease TOTAL. Coat all bevel gear and bevel pinion teeth liberally. Place remaining grease in gearcase cavity.



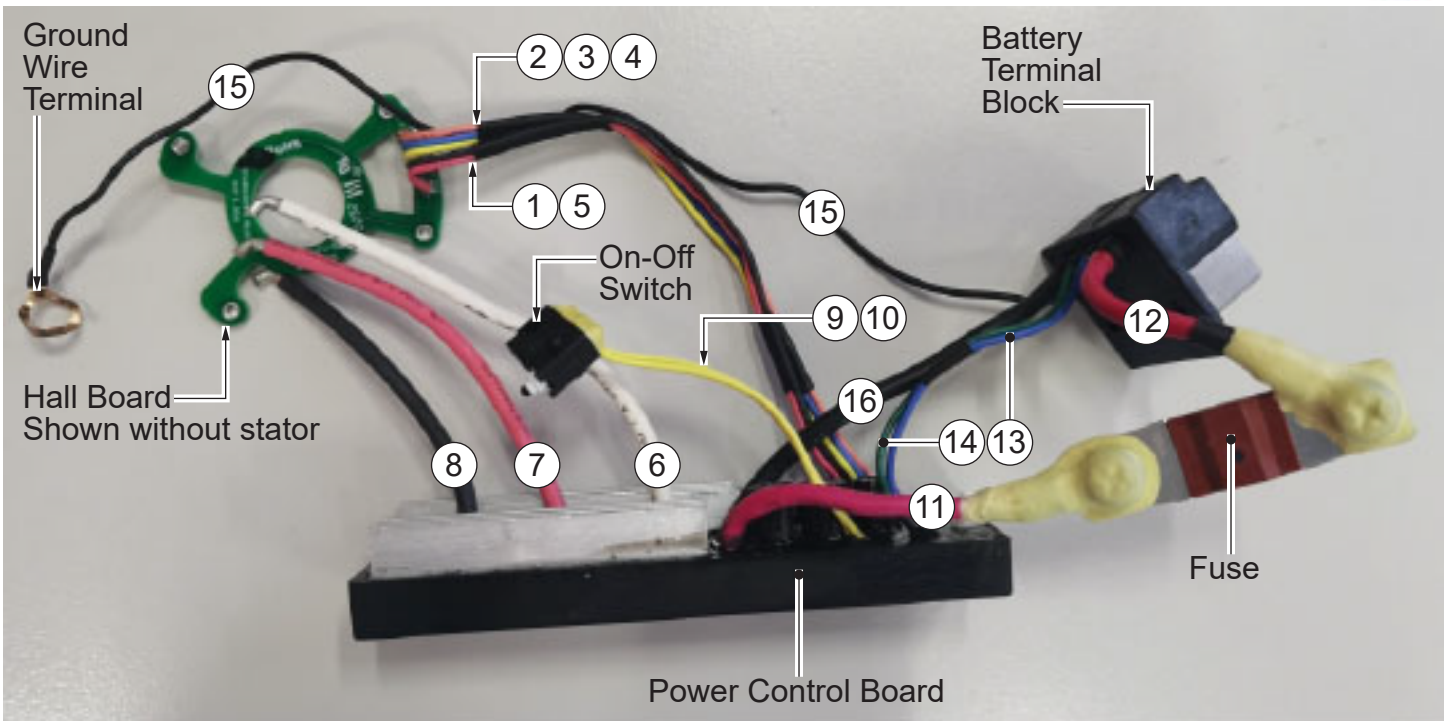

Wire	Color	Orientation
1	Red	From Hall Board to Power Control Board
2	Pink	From Hall Board to Power Control Board
3	Blue	From Hall Board to Power Control Board
4	Yellow	From Hall Board to Power Control Board
5	Black	From Hall Board to Power Control Board
6	White	From Power Control Board to Stator
7	Red	From Power Control Board to Stator
8	Black	From Power Control Board to Stator
9	Yellow	From Power Control Board to On-Off Switch
10	Yellow	From Power Control Board to On-Off Switch
11	Red	From Power Control Board to Fuse
12	Red	From Battery Terminal Block to Fuse
13	Blue	From Power Control Board to Battery Terminal Block
14	Green	From Power Control Board to Battery Terminal Block
15	Black	HV Wire. From Battery Terminal Block to Gearcase
16	Black	From Power Control Board to Battery Terminal Block

As an aid to reassembly, take notice of wire routing and position in wire guides and traps while dismantling tool.

Be sure that all components of the electronics kit are seated firmly and squarely in the housing recesses.

Avoid pinched wires, be sure that all wires and sleeves are pressed completely down in wire guides and traps.

Prior to securing the housing cover onto the housing support, be sure that there are no interferences.

Before installing the battery, check for proper functionality of paddle trigger.

Install battery and depress paddle trigger to assure tool is operating properly.