



SERVICE PARTS LIST

BULLETIN NO.
54-32-2700

SPECIFY CATALOG NO. AND SERIAL NO. WHEN ORDERING PARTS		REVISED BULLETIN	DATE
M18™ FUEL™ 7" Polisher			Apr. 2016
CATALOG NO. 2738-20	STARTING SERIAL NO. H15A	WIRING INSTRUCTION SEE REVERSE SIDE	

EXAMPLE:
00 0 Component Parts (Small #)
Are Included When Ordering
The Assembly (Large #).

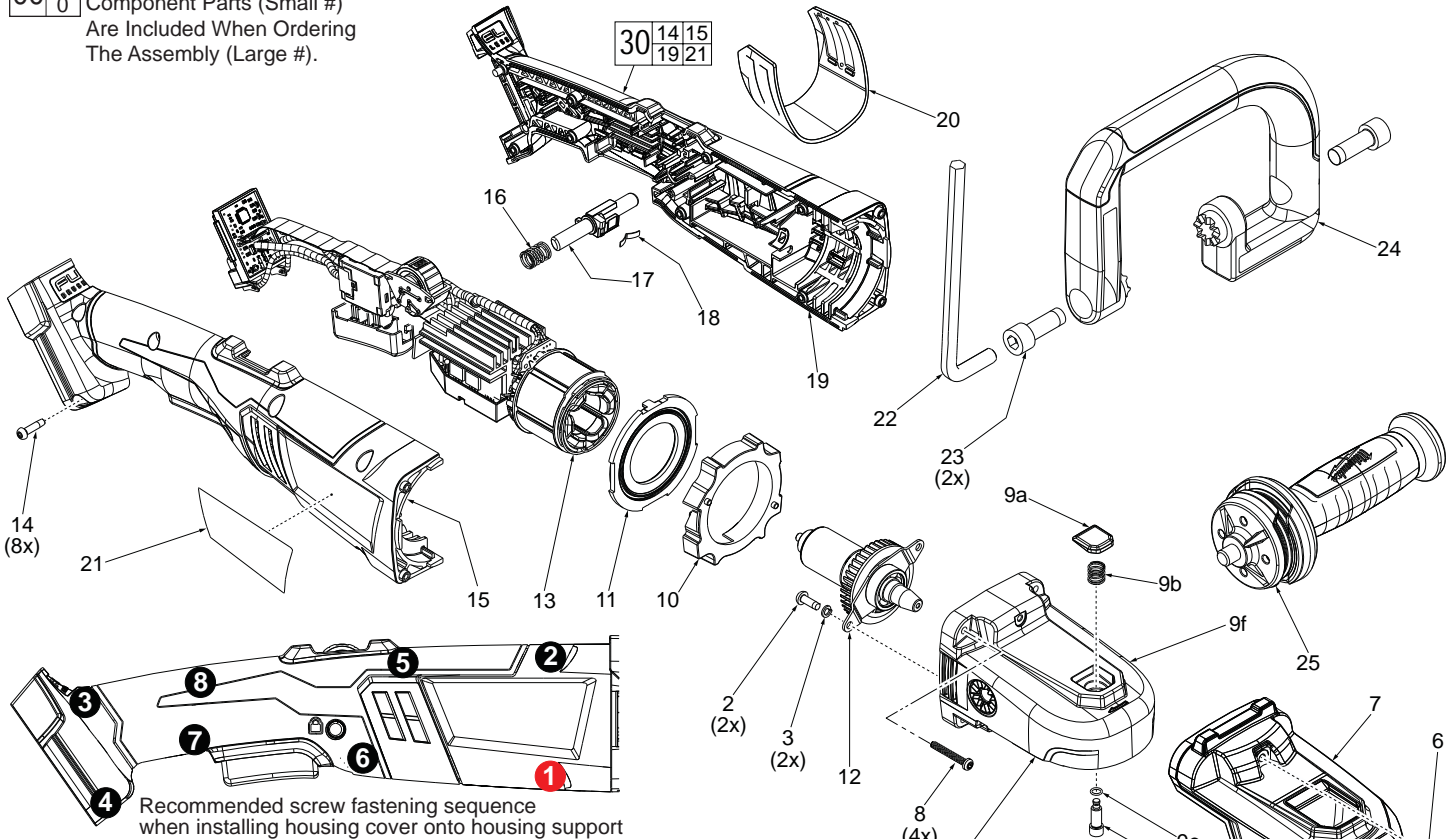
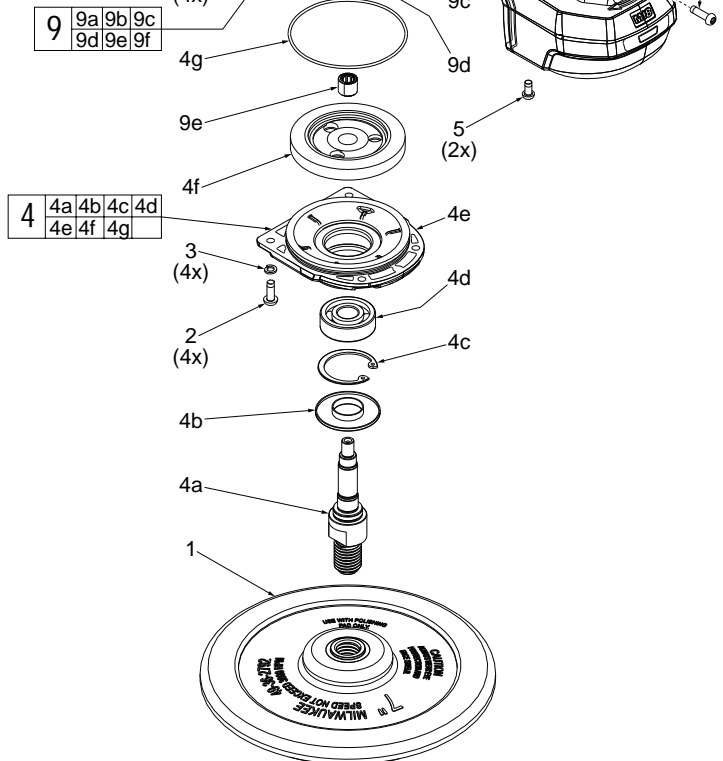
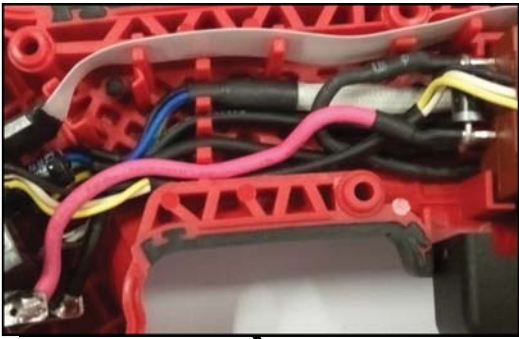

FIG.	PART NO.	DESCRIPTION OF PART	NO. REQ.
1	49-36-2792	7" Hook and Loop Backing Plate	1
2	06-82-2380	8-32 x 12mm Pan Hd. Tapt. T-20 Screw	6
3	05-90-0225	Spring Washer	6
4	14-73-0022	Spindle Hub Assembly	1
4a	-----	5/8"-11 Output Shaft	1
4b	-----	Dust Proof Cover	1
4c	34-80-0210	Retaining Ring	1
4d	-----	Ball Bearing	1
4e	-----	Spindle Hub	1
4f	-----	Bevel Gear	1
4g	34-40-0097	O-Ring	1
5	06-82-3007	M4 x 0.7 x 8mm Pan Hd. T-20 Screw	2
6	05-88-1210	M4 x 0.7 x 14mm Pan Hd. T-20 Screw	1
7	31-55-0022	Gear Case Shroud	1
8	05-88-1300	M4 x 1.4 x 28mm Pan Hd. ST T-20 Screw	4
9	14-30-2738	Gear Case Assembly	1
9a	31-12-0042	Spindle Lock Button	1
9b	40-50-1330	Spindle Lock Spring	1
9c	34-40-0450	O-Ring	1
9d	42-60-0600	Spindle Lock Pin	1
9e	02-50-0025	Needle Bearing	1
9f	-----	Gear Case	1
10	42-14-0005	Baffle Scroll	1
11	42-14-0007	Baffle Foot	1
12	16-01-2738	Rotor Assembly	1
13	14-20-2738	Electronics Assembly	1
14	05-88-1200	M4 x 1.4 x 16mm Pan Hd. ST T-20 Screw	8
15	-----	Housing Cover (Right Housing)	1
16	40-50-0059	Lock On-Off Spring	1
17	42-42-0102	Lock On-Off Shuttle	1
18	40-50-0027	Plate Spring	1
19	-----	Housing Support (Left Housing)	1
20	31-15-0222	Mesh Filter Assembly	1
21	12-20-2738	Service Nameplate	1
22	49-96-0380	5/16" Hex Key	1
23	06-10-0665	M10 x 1.5 x 28mm Hex Hd. Bolt	2
24	31-05-0037	Bail Handle	1
25	42-62-0125	AVS Side Handle	1
30	31-44-2738	Housing Assembly	1
	45-76-2738	Pad Centering Tube (Not Shown)	1





Carefully place/route ribbon cable in traps as shown.

Route all wires and wire groupings through wire traps as shown. Be sure to push wires, sleeved wire groupings and ribbon cables firmly below wire trap openings.

Avoid bending wires sharply from switch.

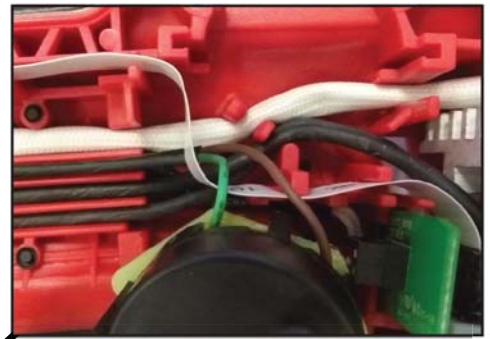

Ferrite Bead
(Not used on UL models)



Be careful and do not tighten or strain the wires in this area.

- As an aid to reassembly, take notice of wire routing and position in wire guides and traps while dismantling tool.
- Be sure that all components of the electronics kit are seated firmly and squarely in the handle recesses.
- Avoid pinched wires, be sure that all wires and sleeves are pressed completely down in wire guides and traps.
- Prior to installing the handle cover onto the handle support, be sure that there are no interferences.

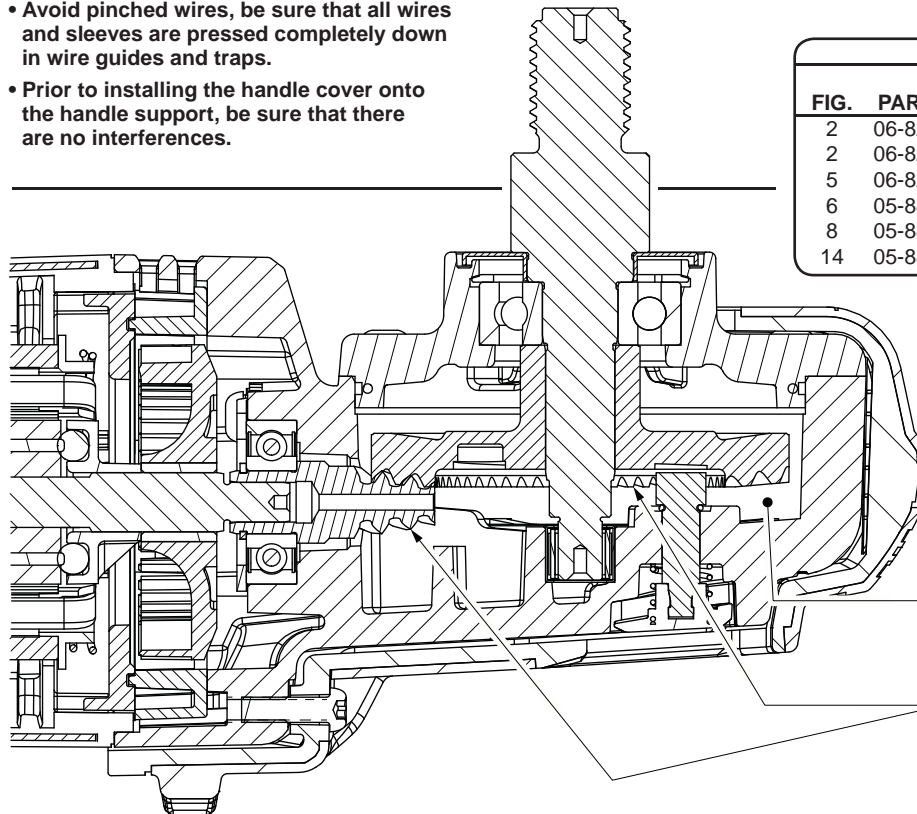

SCREW TORQUE SPECIFICATIONS

FIG.	PART NO.	WHERE USED	SEAT TORQUE	
			(KG/CM)	(IN/LBS)
2	06-82-2380	Spindle Hub	21.5±1.5	18.6±1.3
2	06-82-2380	Rotor Mounting Plate	21.5±1.5	18.6±1.3
5	06-82-3007	Gear Case Shroud	13.5±1.5	11.7±1.3
6	05-88-1210	Gear Case Shroud	13.5±1.5	11.7±1.3
8	05-88-1300	Gear Case	20.0±1.5	17.3±1.3
14	05-88-1200	Housing Cover	19.0±2.0	16.5±1.7

When servicing, remove 90-95% of the existing grease prior to installing Type 'Y'. Original grease may be similar in color but not compatible with 'Y'.

LUBRICATION NOTES:

Use Type 'Y' Grease, No. 49-06-5270 (6 ounce tube)
No. 49-06-5275 (14 ounce tub)

Place 18.5±1.5 grams of grease in the Gear Case cavity, around the Pinion and above and below the Bevel Gear.

Place a heavy coating of grease to the teeth of the Bevel Gear #4f and to the teeth of the Pinion Gear on the Rotor Assembly #12. Use approximately 9.0±1.0 grams of grease.