

ENCLOSURE

MH3300 Series

Metal Housing, NEMA 1, 12.50" H x 12.50" W x 7.00" D

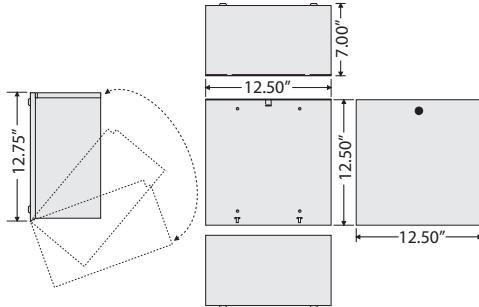

MH3300 SERIES ASSEMBLIES

Model #	Enclosure	Cover Type	Sub-Panel	Weight
MH3300	MH3300	Vertical Lift Screw Down		10.5 lbs.
MH3300K	MH3300K	Vertical Lift Key Latch		10.7 lbs.
MH3303	MH3300	Vertical Lift Screw Down	SP3303 ¹	11.8 lbs.
MH3304	MH3300	Vertical Lift Screw Down	SP3304 ²	11.8 lbs.
MH3303K	MH3300K	Vertical Lift Key Latch	SP3303 ¹	12.5 lbs.
MH3304K	MH3300K	Vertical Lift Key Latch	SP3304 ²	12.5 lbs.

¹ = Polymetal
11.33" H x 11.40" W

² = Perforated Steel
11.33" H x 11.40" W



SPECIFICATIONS

Construction: 18 Gauge Steel

Approvals: UL Listed, C-UL, CE Approved, RoHS

Notes:

- Consult factory for custom colors for large orders.