



**WAYNE  
COMBUSTION  
SYSTEMS**

3623 INDEPENDENCE DRIVE  
FORT WAYNE, IN 46808  
PHONE: (260) 425-9200 or (800) 443-4625  
www.waynecombustion.com

# MODELS

ALL P250 AND P265 SERIES

## GAS BURNERS

Manual 101220 | Revision E | Publication Date: 1/31/26  
NOTE: Dimensions in ( ) are informational only. English values take priority.



**P250-E**

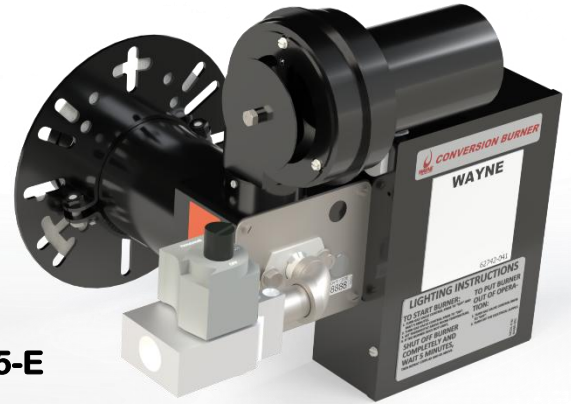

**P265-E**

## SPECIFICATIONS

### BURNER MODELS

### MINIMUM INPUT

### MAXIMUM INPUT

### FUELS

P250AF & P250AF-EP & P250AFDI-E 50,000 Btu/hr (15 kW)  
P265 & P265EP & P265DI 65,000 Btu/hr (19 kW)  
P265F & P265FEP & P265FDI-E 65,000 Btu/hr (19 kW)

250,000 Btu/hr (73 kW)  
200,000 Btu/hr (59 kW)  
200,000 Btu/hr (59 kW)

Natural & L.P. Gas  
Natural & L.P. Gas  
Natural & L.P. Gas

**ELECTRICAL** Power Supply – 115V/60HZ 1 Ph.

**MOUNTING:** Adjustable Flange is Standard; Pedestal Mount is Optional



**READ THIS MANUAL BEFORE USING THIS PRODUCT. FAILURE TO FOLLOW THE INSTRUCTIONS AND SAFETY PRECAUTIONS IN THIS MANUAL CAN RESULT IN SERIOUS INJURY OR DEATH. KEEP THIS MANUAL FOR FUTURE REFERENCE. INCORRECT INSTALLATION, ADJUSTMENT, OR MISUSE OF THIS BURNER WILL VOID THE WARRANTY.**



**INSTALLATION OF THE BURNER MUST BE DONE BY A QUALIFIED INSTALLER IN ACCORDANCE WITH REGULATIONS OF THE NATIONAL FUEL GAS CODE ANSI Z223.1/NFPA54, AND IN COMPLETE ACCORDANCE WITH ALL LOCAL CODES AND AUTHORITIES HAVING JURISDICTION.**

**A QUALIFIED INSTALLER IS THE PERSON WHO IS RESPONSIBLE FOR THE INSTALLATION AND ADJUSTMENT OF THE EQUIPMENT AND WHO IS LICENSED TO INSTALL GAS-BURNING EQUIPMENT IN ACCORDANCE WITH ALL CODES AND ORDINANCES.**

**BURNER IS SHIPPED AT MINIMUM RATE AND MAX AIR. BURNER MAY NOT LIGHT IN THIS CONFIGURATION AND WILL NEED AIR ADJUSTMENT**

**CSA CERTIFICATE NUMBER: 1156769**



## Overview of Safety Warning System and Your Responsibilities

The safety of you and others depends upon you thoroughly reading and understanding this manual. If you have questions or do not understand the information presented in this manual, **please call Wayne Combustion System or see [www.waynecombustion.com](http://www.waynecombustion.com)**.



This is the safety alert symbol. It is used to alert you to potential personal injury hazards. The meaning of this safety alert symbol is as follows: **Attention! Become alert! Your safety may be at risk.** The message that appears next to the warning which can be either written or pictorially presented. **NEVER** remove or tamper with the warning labels, safety devices or guards fitted on the unit.

Wayne Combustion System is **NOT** responsible for any bodily injury and/or property damage that may result from operation outside of the stated operating conditions for which this unit was intended.

### Hazard Definitions:



Indicates a hazardous situation, which, if not avoided, will result in **death or serious bodily injury**.



Indicates a hazardous situation, which, if not avoided, could result in **death or serious bodily injury**.



Indicates a hazardous situation, which, if not avoided may result in **minor or moderate bodily injury**.



Indicates a situation that may result in equipment-related damage.



#### Fire or Explosion Hazard



***Can cause severe injury, death, or property damage  
If the information in these instructions is not followed exactly, a fire or explosion may result causing property damage, personal injury, or death.***

**DO NOT STORE OR USE GASOLINE OR OTHER FLAMMABLE VAPORS AND LIQUIDS IN THE VICINITY OF THIS OR ANY OTHER APPLIANCE.**

#### WHAT TO DO IF YOU SMELL GAS:

- Open Windows.
- Do not try to light any appliances.
- Do not touch electrical switches; do not use any phone in your building.
- Extinguish any open flame.
- Immediately call your gas supplier from a neighbor's phone. Follow the gas supplier's instructions.
- If you cannot reach your gas supplier, call the fire department.



## CARBON MONOXIDE POISONING HAZARD

**CARBON MONOXIDE IS A COLORLESS, ODORLESS GAS THAT CAN KILL. FOLLOW THESE RULES TO CONTROL CARBON MONOXIDE.**

- Do not use this burner if in an unvented, enclosed area. Carbon monoxide may accumulate.
- Do not adjust the pressure regulator. High pressures produce carbon monoxide.
- Check flue gases for carbon monoxide. This check requires specialized equipment.
- Allow only qualified burner service persons to adjust the burner. Special instruments and training are required.
- Read the burner manual before using.



## ELECTRIC SHOCK HAZARD



**HIGH VOLTAGES ARE PRESENT IN THIS EQUIPMENT. FOLLOW THESE RULES TO AVOID ELECTRIC SHOCK**

- Use only a properly grounded circuit. A ground fault interrupter is recommended.
- Do not spray water directly on burner.
- Turn off power before servicing.
- Read the owner's manual before using.



## OVERHEATING HAZARD



**SHOULD OVERHEATING OCCUR:**

- Shut off the manual gas control to the appliance.
- DO NOT shut off power to the equipment, allow blower to continue running.



## EXPLOSION HAZARD



**NEVER ATTEMPT TO USE GASOLINE AS A FUEL FOR THIS BURNER, AS IT IS MORE COMBUSTIBLE AND COULD RESULT IN A SERIOUS EXPLOSION.**



#### **P250 SERIES FLAME SPREADER:**

For shipping purposes, the flame spreader on the P250 Series burners is shipped in the fully retracted position. Flame spreader adjustment is mandatory and affects burner ignition and performance.



#### **SPECIAL REQUIREMENTS:**

When contacting Wayne Combustion Systems for service information,

**Please have the burner specification number and model number when calling or writing.** Specification number and model number are located on top of the junction box which is strapped to the motor on the burner. For -E Series burners, specification and model number will appear on front of electrical enclosure box.

**If any instructions in the manual are not clear, contact Wayne Combustion Systems at 1-260-425-9200 for assistance.**



## Contents

SECTION I: INSTALLATION AND SETUP.....	8
<b>VISUAL INSPECTION OF THE HEATING SYSTEM .....</b>	<b>8</b>
<b>INSPECTION OF FLUE PIPE AND CHIMNEY .....</b>	<b>9</b>
<b>INSPECTION OF HEATING APPLIANCE.....</b>	<b>10</b>
<b>FLUE PIPE, DRAFT HOOD, AND BAROMETERIC DAMPER .....</b>	<b>10</b>
<b>PREPARATION OF COMBUSTION CHAMBER .....</b>	<b>12</b>
<b>SIZING OF COMBUSTION CHAMBER.....</b>	<b>13</b>
<b>BURNER INSTALLATION .....</b>	<b>14</b>
<b>INSTALLATION OF MOUNTING FLANGE .....</b>	<b>14</b>
<b>DETERMINE ORIFICE SIZE AND RATE .....</b>	<b>15</b>
<b>CHANGING THE ORIFICE .....</b>	<b>17</b>
<b>INSPECTION AND SIZING OF GAS PIPING .....</b>	<b>19</b>
<b>TESTING PIPING FOR LEAKS .....</b>	<b>21</b>
<b>ELECTRICAL WIRING OF BURNER.....</b>	<b>21</b>
<b>INSPECTION OF LIMIT CONTROL SWITCHES .....</b>	<b>22</b>
<b>INSTALLATION OF THERMOSTAT.....</b>	<b>22</b>
SECTION II: INITIAL START UP .....	24
<b>OPERATION OF BURNER (DIRECT SPARK IGNITION) .....</b>	<b>24</b>
<b>OPERATION OF BURNER (ELECTRONIC PILOT).....</b>	<b>26</b>
<b>OPERATION OF BURNER (STANDING PILOT) .....</b>	<b>27</b>
<b>COMBUSTION ADJUSTMENT OF BURNER.....</b>	<b>28</b>
<b>FINAL INSTALLATION INSTRUCTIONS .....</b>	<b>29</b>
SECTION III: GAS CONVERSION .....	30
<b>NATURAL GAS AND LP CONVERSION INSTRUCTIONS .....</b>	<b>30</b>
SECTION IV: CONSUMER INSTRUCTIONS.....	31
<b>GENERAL INSTRUCTIONS FOR SERVICING BURNER .....</b>	<b>31</b>
SECTION V: SERVICE AND TROUBLESHOOTING .....	32
<b>NORMAL OPERATION CHECK OF BURNER (DIRECT IGNITION) .....</b>	<b>32</b>
<b>NORMAL OPERATION CHECK OF BURNER (ELECTRONIC PILOT-Fenwal).....</b>	<b>33</b>
<b>NORMAL OPERATION CHECK OF BURNER (ELECTRONIC PILOT-Honeywell).....</b>	<b>34</b>
<b>TROUBLESHOOTING GUIDE DIRECT IGNITION.....</b>	<b>35</b>
<b>TROUBLESHOOTING TERMINAL BLOCKS (-E SERIES ONLY).....</b>	<b>35</b>
<b>TROUBLESHOOTING GUIDE (ELECTRONIC PILOT) .....</b>	<b>36</b>
<b>PRELIMINARY CHECKS, DIAGNOSIS AND SERVICE HINTS (ELECTRONIC PILOT) .....</b>	<b>37</b>

<b>COMPONENT TROUBLESHOOTING AND DIAGNOSIS .....</b>	<b>38</b>
<b>MORE SERVICE HINTS .....</b>	<b>39</b>
<b>P265 DIRECT IGNITION IGNITOR POSITION .....</b>	<b>40</b>
<b>P250 DIRECT IGNITION IGNITOR POSITION .....</b>	<b>40</b>
<b>P250/P265 NON -E SERIES WIRING DIAGRAMS.....</b>	<b>41</b>
<b>P250/P265F -E SERIES WIRING DIAGRAM .....</b>	<b>47</b>
<b>SECTION VI: PARTS LIST AND EXPLODED VIEWS.....</b>	<b>48</b>
<b>P265F EXPLODED VIEWS.....</b>	<b>48</b>
<b>P265F PARTS LIST .....</b>	<b>50</b>
<b>P250AF EXPLODED VIEWS.....</b>	<b>51</b>
<b>P250AF PARTS LIST .....</b>	<b>53</b>
<b>P250AF -E EXPLODED VIEW.....</b>	<b>54</b>
<b>P250AF -E SERIES PARTS LIST .....</b>	<b>55</b>
<b>P265F -E EXPLODED VIEW.....</b>	<b>56</b>
<b>P265F -E SERIES PARTS LIST .....</b>	<b>57</b>
<b>SECTION VII: WARRANTY .....</b>	<b>58</b>

## SECTION I: INSTALLATION AND SETUP

These instructions were prepared for the guidance of those installing this particular gas conversion burner. While they apply in principle to all installations, they should not be interpreted as meaning the only safe and economical way to install a conversion burner. It may be necessary to deviate from these instructions in some instances in order to comply with local gas company rules or codes in effect in the area in which the installation is made. It is recommended that the installer confer with the local gas company and with the proper municipal officials regarding any specific code or regulation governing the installation of gas conversion burners. The installation must conform with local codes or, in the absence of local codes, with the American National Standard ANSI Z21.8 Installation of Domestic Gas Conversion Burners and ANSI Z223.1 the National Fuel Gas Code, latest version.

Safe and economical operation of the burner throughout its service life is dependent to a large extent upon its proper installation in the heating appliance. Therefore, we may impress upon the installer that good clean workmanlike installations mean satisfied customers.

### VISUAL INSPECTION OF THE HEATING SYSTEM

A conversion burner shall not be installed in an appliance located in a room or basement where facilities for normal air circulation or infiltration are so limited so as to interfere with ready obtainment of all air necessary for proper combustion and draft hood dilution, unless at the time of burner installation special provisions are made for combustion and draft hood dilution air.

- In open basements of homes of normal construction (without basement storm windows or tight stair doors) infiltration of combustion air is usually sufficient to replace that drawn up the flue, so special provisions are seldom necessary.
- When the heating appliance is installed in a tightly closed room without ventilating openings to outdoors or other rooms, provisions shall be made for supplying air for combustion through special openings, one near the floor line and the other near the ceiling, each to be sized on the basis of one square inch or more of free area for each 1,000 Btu/hr (0.2931 Kw) input but not less than 100 square inches. (See Figure 1).
- When the house is of unusually tight construction, has a (kitchen) ventilating fan which may be used for exhausting air from indoors, or has a vented fireplace, it is recommended that combustion air be supplied to the furnace room through intakes extending to the outside of the building and terminating in down turned fittings, suitably arranged to prevent obstruction from snow or rain, and including a protecting screen not smaller than 1/4-inch (6.35 mm) mesh.

Ventilating Air Opening  
1 Sq. in. (645.2 mm<sup>2</sup>)  
for each 1,000 Btu  
(.29 kW) per hour  
Input, 100 Sq. in. minimum.

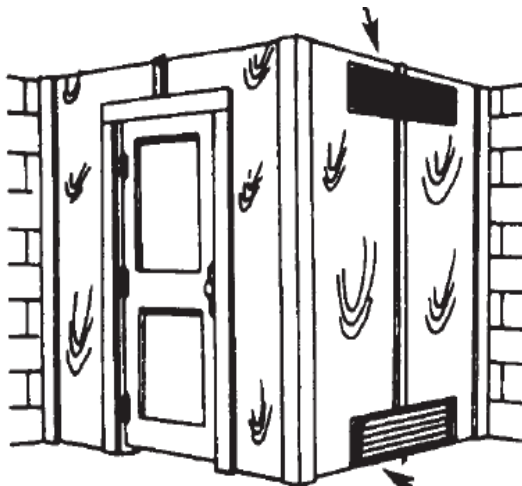

Illustration above shows air opening necessary to supply air for combustion when heating appliance is installed in an enclosed room.

Air Inlet Opening 1 Sq. in. (645.2 mm<sup>2</sup>) for each 1,000 Btu (.29 kW) per hour input, 100 Sq. in. minimum.

FIGURE 1

Application below located in confined spaces. Ventilation air from inside building – combustion and draft hood dilution air from outside with ventilated attic or ventilated crawl space.

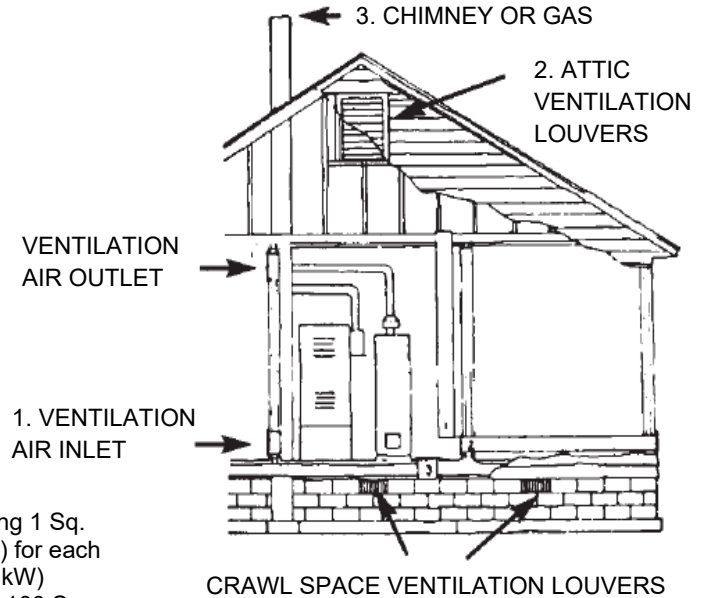

FIGURE 2

**NOTE ON FIGURE 2:** Ducts used for make-up air may be connected to the cold air return of the heating system only if they connect directly to outdoor air. Attic Ventilation Louvers are required at each end of attic with alternate air inlet No. 1.

1, 2, and 3 mark alternate locations for air from outdoors. Free area shall be not less than 1 Sq.in. (645.2 mm<sup>2</sup>) per 5,000 Btu (.1.465 kW) per hour of the total input rating of all appliances in the enclosure.

Crawl-space Ventilation Louvers for unheated crawl space are required with alternate air inlet No. 3.

Each Ventilation Air Opening from inside the building shall have a free area of not less than 1 Sq. in. (645.2 mm<sup>2</sup>) per 5,000 Btu (.1.465 kW) per hour of the total input rating of all appliances in the enclosure.

The heating system (both the heat exchanger and distribution system) shall be of a size to properly heat the building. Through inquiry it shall be determined that all rooms have been heated adequately without wide variations in temperature, without objectionable drafts, and without excessive fuel costs in the past. If the heating system is deficient with respect to any of the above determinations, provisions shall be made to correct the deficiency, replace obsolete parts, or (by installing storm windows, insulation, etc.) to reduce the heat loss to a point where the existing system will provide the proper amount of heat.

a. Gravity Warm Air System

The supply and return ducts and registers should be sized and arranged so that the house can be heated without excessive furnace temperatures. Reference may be made to the American Society of Heating, Refrigerating and Air-Conditioning Engineers Guide and Data Book series and Handbook of Fundamentals.\*

b. Forced Warm Air Systems

Inspection should also show whether the electrical characteristics of the fan and limit switch are satisfactory and whether the air filters and fan are in condition for continued proper service with the gas burner. Reference may be made to the American Society of Heating, Refrigerating and Air-Conditioning Engineers Guide and Data Book series and Handbook of Fundamentals.\*

c. Hot Water Systems

The boiler thermometer and altitude gauge should be in good order. On a closed system, the feed and pressure relief valves shall be in proper operating condition. If there is an expansion tank on a closed system, inspection should show it to be substantially empty of water. When there is an existing water temperature limiting switch, its operating and electrical characteristics shall be checked to determine its suitability to the gas control circuit. For common piping systems reference can be made to the American Society of Heating, Refrigerating and Air-Conditioning Engineers Guide and Data Book series\* and to the Hydronic Institute I=B=R Guides.\*\*

d. Steam or Vapor System

The system shall be pressure tight, with pressure gauge and pop safety valve in good condition and with an existing water glass which permits clear observation of boiler water level. When there is a pressure limit switch or low-water cut-off, inspection shall determine whether either device can be utilized in the gas burner control circuit, reference should be made to the American Society of Heating, Refrigerating and Air-Conditioning Engineers and Institute of Boiler and Radiator Manufacturers guides. Traps and air vents shall be of adequate capacity, in good condition, and correctly placed in the system.

\*Copies may be obtained from the <http://www.ashrae.org>

\*\*Copies may be obtained from the Hydronic Institute, 35 Russo Place, Berkeley, NJ 07922.

### INSPECTION OF FLUE PIPE AND CHIMNEY

- The flue pipe should be carefully inspected and replaced if necessary in connection with installation of a draft hood. A barometric damper may be used per Flue Pipe, Draft Hood, and Barometric Damper section of manual. All installations must operate with a negative draft overfire. Refer to your local gas company or codes for assistance or to the furnace and/or boiler manufacturer for recommendations.
- The flue pipe entrance into the chimney should be at least two feet (0.610m) above the clean-out opening in the chimney.
- The chimney should extend high enough above the dwelling or other neighboring obstructions so that wind from any direction will not strike the chimney from any angle above horizontal. Unless the obstruction is of greater magnitude, it is the usual experience that a chimney extending two feet above flat roofs or above fire wall parapets, and peaked roofs within 30 feet (9.144m) will be reasonably free of downdraft.
- Where the chimney is unlined or where local experience indicates that flue gas condensate might be a problem, the local gas company should be consulted.
- The chimney should be examined and thoroughly cleaned, if necessary, before installation is made to make sure it will freely conduct the flue gases to the outside.
- Flue pipe should extend through the chimney wall to the inner face of the chimney liner but not beyond, and should be firmly cemented to masonry. A thimble may be used to facilitate removal of flue pipe for cleaning, in which event the thimble should be permanently cemented in place with mortar or other fireproof material that will not crack or check the flue pipe or thimble, whichever is used, should be sealed into the chimney liner.
- Flue connections from two or more appliances should not enter opposing or adjacent sides of the chimney at the same level.
- Under no circumstances should the flue pipe be connected to a flue of an open fireplace.

## INSPECTION OF HEATING APPLIANCE

Clean the appliance heat exchanger interior, combustion chamber and flue connections. Remove all adhering tars, scale, dirt, and soot. Inspect the heat exchanger for obvious and potential flue gas leaks. Cement all joints around the appliance base and access openings to prevent air and/or flue gas leakage into or out of the combustion chamber.

Warm Air Furnaces\* - Make certain the electrical characteristics of the fan and limit switch correspond to those required by this burner and that they are in proper working order.

Hot Water Boilers\* - Make certain water temperature and altitude gauges, pressure relief valves are in proper working order.

Steam Boilers\* - Make certain the system is pressure tight and that the pressure gage and pop off safety valve are in proper working order. Verify existing water sight glass permits clear observation of boiler water level.

\*Where applicable, existing temperature of pressure limit switch or low water cut-off switch operation and electrical characteristics shall be checked to determine their compatibility to the gas control circuitry of this burner.

**NOTE:** For oil fired conversions consult boiler or furnace manufacturer. Appliance must maintain negative draft over fire.

### FLUE PIPE, DRAFT HOOD, AND BAROMETRIC DAMPER

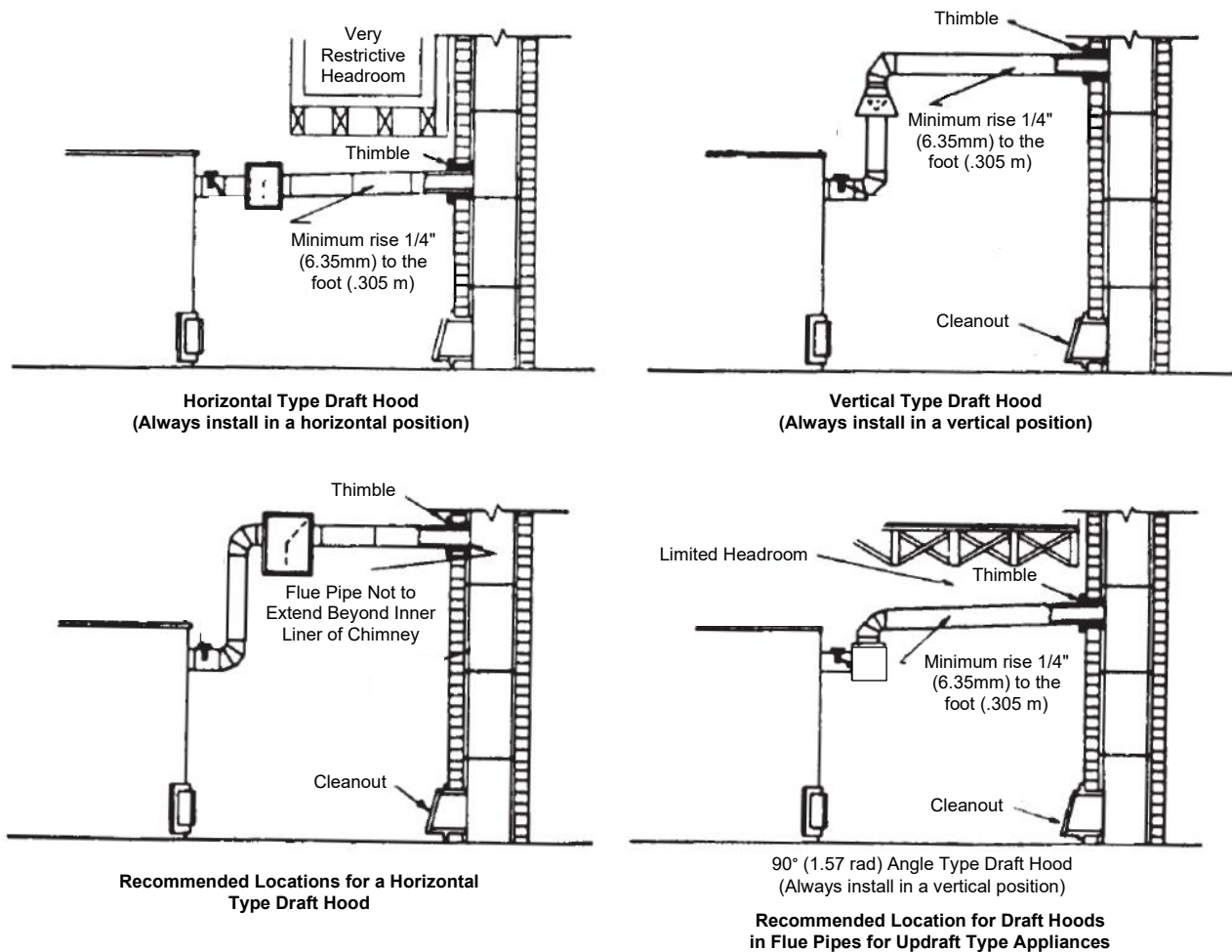

**FIGURE 3: DRAFT HOOD LOCATIONS**

A CSA type draft hood or its equivalent shall be placed in and made part of the flue pipe from the appliance. A barometric damper may be used in place of the draft hood where permitted by local building codes. If an oil barometric damper has been previously installed this may be used if it is in good condition and any and all weights and/or stops are removed. The flapper on a gas barometric damper must be free swinging in both directions. Check with local building codes and building inspectors. At no time should the draft hood be located at a point lower than the highest flue passage in the appliance. The draft hood should be installed in the position for which it was designed and in no case installed in a false ceiling, separate room from the heating appliance, or in any other manner that will permit a difference in pressure between the draft hood relief opening and the combustion air supply. On sealed type appliances where all combustion air is taken from the outside, a cap should be installed on end of flue pipe to prevent back drafts. In such cases no draft hood or diverter should be installed inside (See Figure 3).

When converting oil fired appliances, the flue pipe and draft hood or diverter used should be the same size as the furnace flue collar. It is recommended that a rise as great as possible or at least 1/4 inch (6.35mm) to the foot (0.305m) (horizontal length) be maintained in the flue pipe from the appliance to the chimney. The flue pipe should be relocated where possible to avoid sharp turns.

**DRAFT** – When installing Wayne power gas burners in oil fired boilers a minimum negative draft of .02" (5 Pa) w.c. over fire must be maintained. Refer to your local gas company and codes for assistance.

For gas fired equipment requiring a double acting barometric the preferred location of the barometric draft control is part of the bullhead tee shown in Figure 4. During normal operation, flue gases make a right angle turn behind the control, but do not infringe upon it. Should a downdraft occur, air flowing in the opposite direction strikes the control directly, causing it to open outwardly and vents the air into the room with a minimum of resistance. Entrained products of combustion are thus provided greater relief.

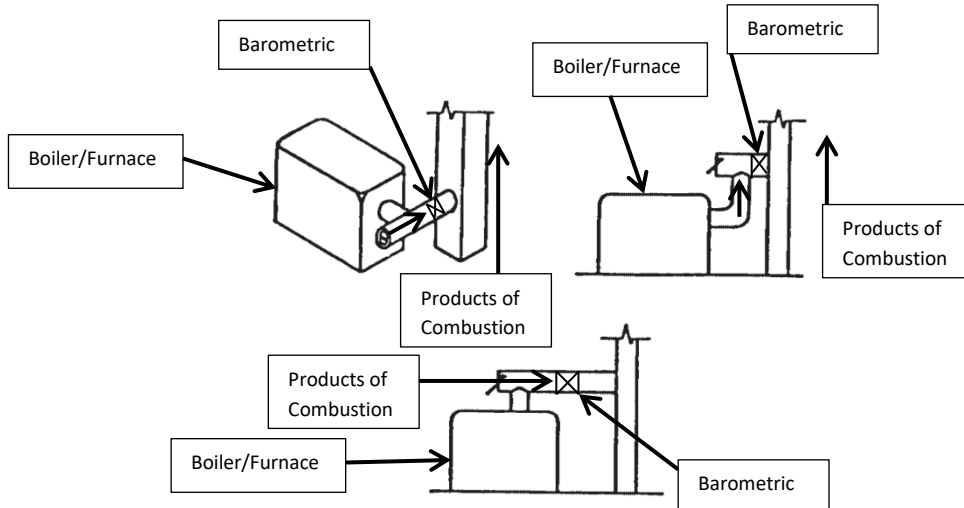

**FIGURE 4: BEST LOCATIONS FOR BAROMETRIC DRAFT CONTROL**

**DRAFT HOOD & FLUE PIPE SIZES FOR GAS CONVERSION BURNERS IN FURNACES AND BOILERS**

Not more than 6,500 Btu/hr (1.905 Kw) per square inch (645.2 mm <sup>2</sup> ) of the flue area	
Input – Btu/hr (Kw)	Draft Hood and Flue Pipe Size
Up to --- 120,000 (35)	5 inch (127 mm)
120,000 (35.17) --- 180,000 (53)	6 inch (152 mm)
180,000 (52.75) --- 250,000 (73)	7 inch (178 mm)

- NOTE: If the flue pipe exceeds 10 ft. (3.048m) in length, or contains more than two elbows, use next size larger pipe and draft hood.
- NOTE: All installations must operate with negative draft overfire. Refer to your local gas company and codes for assistance.

When installing the burner in revertible flue (down draft or diving flue type) furnaces or boilers, the draft hood (or draft diverter) should be located at least one foot higher than the top of the highest point of the appliance flue passage or combustion chamber. It is also recommended that a vent pipe, not less than one inch in diameter, be provided from the highest point in the flue passage, directly to the flue pipe. This is not necessary on the appliances with built in up draft bypass. The gas company serving the area should be consulted in regards to their recommendations for converting this type of furnace or boiler.

The flue pipe should be securely supported and the joints fastened with sheet metal screws or riveted to prevent sagging, and in no case should be located in a manner that will present a hazard to combustible building material. (Refer to local building code.)

## PREPARATION OF COMBUSTION CHAMBER

Clean the combustion chamber thoroughly. Scrape and brush all heating surfaces and flue ways. Soot and fly ash are excellent insulators and unless removed, the efficiency of the heating appliance will be impaired. Plugged or restricted flue passages will prevent burner from operating properly.

Be sure water column and gauge on boiler are clean and water level is visible. In all cases make sure the pigtail to limit control is clear. Safety pop valves on steam boilers and automatic relief valves on closed water systems should be thoroughly checked to make sure they are in good working condition.

When converting oil designed boilers and furnaces, it is recommended that the existing combustion chamber be used with the gas burner, provided it is in good condition. If the blast tube opening into the combustion chamber is larger than the 4" (102 mm) diameter, high temperature cement should be used to reduce the opening to 4" (102 mm) diameter.

IN NO CASE SHOULD THE TUBE BE ALLOWED TO EXTEND INTO THE CHAMBER PROPER. IT MUST BE AT LEAST 1/8" (3.2mm) SHORT OF THE INSIDE SURFACE OF THE COMBUSTION CHAMBER. (SEE FIGURE 5)

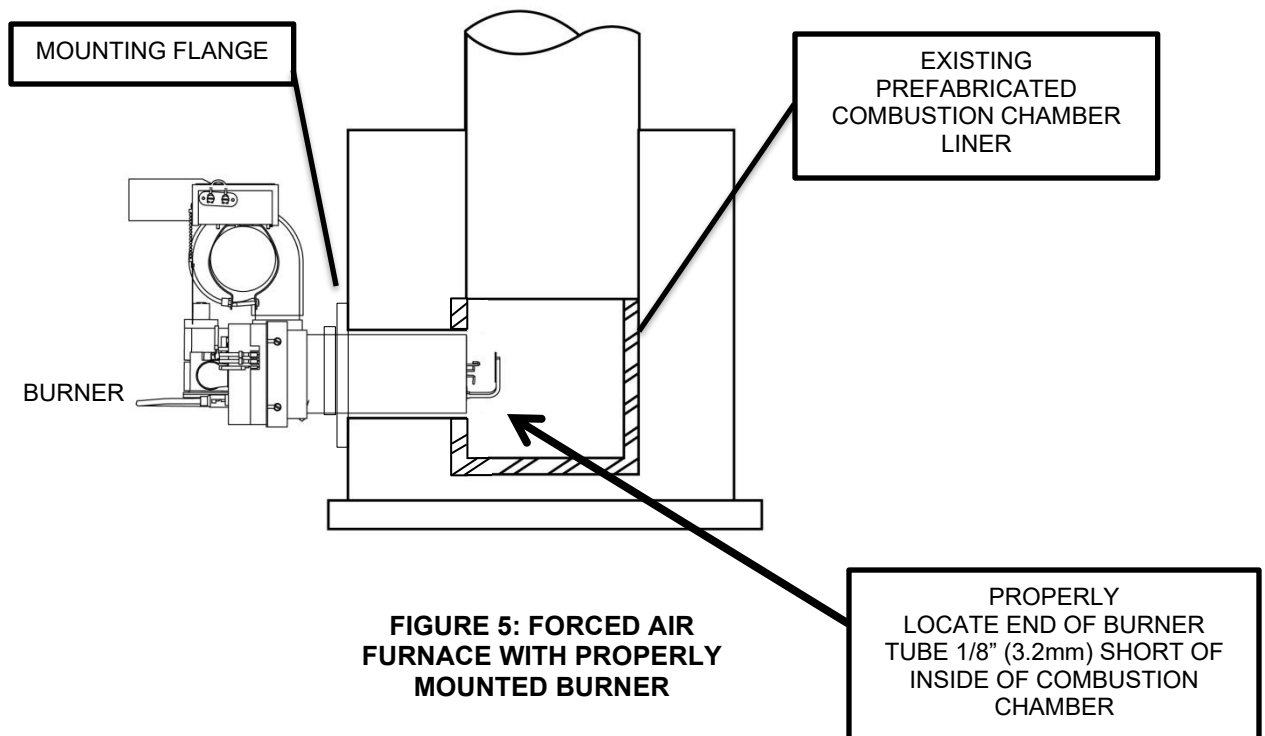

## SIZING OF COMBUSTION CHAMBER

The following tables are provided as a guideline for determining combustion chamber size and corresponding firing rate when appliance rates are not available.

**Table 1: Combustion Chamber for P250 Only**

Input Btu/hr (kW)	Floor Area Sq. Inches (cm <sup>2</sup> )	Preferred Width and Length Inches (cm)
50,000 (15)	49 (316)	7 (17.8) x 7 (17.8)
85,000 (25)	56 ¼ (363)	7 ½ (19.1) x 7 ½ (19.1)
100,000 (29)	64 (413)	8 (20.3) x 8 (20.3)
120,000 (35)	72 ¼ (466)	8 ½ (21.6) x 8 ½ (21.6)
140,000 (41)	81 (523)	9 (22.9) x 9 (22.9)
154,000 (45)	90 ¼ (582)	9 ½ (24.1) x 9 ½ (24.1)
175,000 (51)	100 (645)	10 (25.4) x 10 (25.4)
210,000 (62)	122 (787)	11 (27.9) x 11 (27.9)
240,000 (70)	144 (929)	12 (30.5) x 12 (30.5)
250,000 (76)	156 ¼ (1008)	12 ½ (31.8) x 12 ½ (31.8)

**Table 2: Combustion Chamber for P265 Only**

Input Btu/hr (kW)	Floor Area Sq. Inches (cm <sup>2</sup> )	Preferred Width and Length Inches (cm)
65,000 (19)	63 (407)	7 (17.8) x 9 (22.9)
75,000 (22)	71 ¼ (460)	7 ½ (19.1) x 9 ½ (24.1)
100,000 (29)	125 (807)	10 (25.4) x 12½ (31.8)
150,000 (44)	180 (1161)	12 (30.5) x 15 (38.1)
200,000 (59)	221 (1426)	13 (33.0) x 17 (43.2)

**Table 3: Combustion Chamber for P265F Only**

Input Btu/hr (kW)	Floor Area Sq. Inches (cm <sup>2</sup> )	Preferred Width and Length Inches (cm)
65,000 (19)	63 (407)	7 (17.8) x 9 (22.9)
75,000 (22)	63 (407)	7 (17.8) x 9 (22.9)
100,000 (29)	71 ¼ (460)	7 ½ (19.1) x 9 ½ (24.1)
150,000 (44)	110 (710)	10 (25.4) x 11 (27.9)
200,000 (59)	165 (1065)	11 (27.9) x 15 (38.1)



## DETERMINE ORIFICE SIZE AND RATE

The gas conversion burner needs to be set to deliver the same amount of heat to the appliance as the oil burner it is replacing. Determine the Btu/hr heat input rate for the appliance by locating the rating plate of the appliance and determine the firing rate of the oil burner. Typically the nozzle in the oil burner is stamped with the gallon per hour rate. Use the lesser of these two rates as the firing rate of the gas burner.

For calculating from gallon/hour of oil to Btu/hour of gas, One gallon of oil produces 140,000 Btu/gal (147700 kJ/L) of heat. For example: A furnace rating of 0.60 G.P.H. would be  $0.60 \times 140,000 = 84,000$  Btu/hr. This is the input rate needed from the gas burner.

Once the desired heat output of the burner has been determined, the gas orifice must be properly sized. The gas orifice factory installed in all burners is sized to produce the minimum firing rate of the burner; 50,000 Btu/hr for the P250, 65,000 Btu/hr for the P265.

To determine the proper orifice size for the application, refer to Table 4 below. Locate the drill size by selecting the proper column based on the gas to be used. Example: To fire 80,000 Btu/hr on natural gas requires an orifice drilled with a #19 drill bit (0.166").

**NOTE: Numbered and lettered drill bit sizes are valid bit sizes. They are machinist's drill bits. Decimal values have been provided in Table 4 as assistance in determining closest fractional drill bit size to the number/letter drill bit size.**

The correct manifold pressure for natural gas is 3.5" w.c (872 Pa). Only minor adjustments in the input rate should be made by adjusting the pressure regulator. The minimum manifold pressure should be 3.0" w.c. (747 Pa) and the maximum pressure should be 3.5" w.c. (872 Pa). The next size larger or smaller orifice size should be used if the desired input rating cannot be obtained within the above manifold pressure adjustment range.

The correct manifold pressure for L.P. gas is 10" w.c. (2491 Pa). Only minor adjustments in the input rate should be made by adjusting the pressure regulator. The minimum manifold pressure should be 9.5" w.c. (2366 Pa), the maximum pressure 10.0" w.c. (2491 Pa). If the desired input rating cannot be obtained within the above manifold pressure and adjustment range then the next size larger or smaller orifice size should be used.



**WARNING**

### GAS LEAK HAZARD

**Liquefied petroleum gas is heavier than air. All connections should be checked for leaks using a soapy solution applied to gas connections. Leaking gas will settle in low lying areas such as basements and trenches. This can lead to asphyxiation and explosion.**

**Table 4: Orifice Size and Drill Bit Chart**

Btu/hr(Kw) Input	Natural Gas: 3.5" w.c. (872 Pa)		Propane Gas: 10" w.c. (2491 Pa)	
	Number/ Letter/Fraction	Decimal (in)	Number/Fraction	Decimal (in)
50,000 (15)	29	0.136	45	0.082
60,000 (18)	28 (9/64)	0.1405	44	0.086
65,000 (19)	26	0.147	43	0.089
70,000 (21)	24	0.152	3/32	0.094
75,000 (22)	5/32	0.1562	40	0.098
80,000 (23)	19	0.166	37	0.104
100,000 (29)	17 (11/64)	0.173	35 (7/64)	0.110
110,000 (32)	14	0.182	31	0.120
115,000 (34)	3/16	0.187	3.1 mm	0.122
130,000 (38)	5 (13/64)	0.2055	1/8	0.125
140,000 (41)	4	0.209	30	0.1285
150,000 (44)	7/32	0.2188	29	0.136
160,000 (47)	1	0.228	28 (9/64)	0.1405
170,000 (50)	15/64	0.2344	27	0.144
175,000 (51)	B	0.238	26	0.147
185,000 (54)	1/4	0.250	25	0.150
200,000 (59)	G	0.261	22 (5/32)	0.157
210,000 (62)	17/64	0.266	20	0.161
220,000 (64)	I	0.272	19	0.166
235,000 (69)	9/32	0.281	11/64	0.172
250,000 (73)	M (19/64)	0.295	16	0.177

NOTE: The Btu/hr input values in Table 4 show the approximate hourly input of the burner for the various drill bit sizes shown. To determine the actual input of the burner by using the gas meter, follow these steps:

- 1) Turn off all other gas appliances.
- 2) The hand on the dial with the lowest cubic feet value (fastest revolving dial) should be clocked for one complete revolution.
- 3) Divide 3,600 by the time in seconds for one complete revolution and multiply by the dial value (1, 2, or 5 cubic feet depending on size of meter.)
- 4) Multiply this by the heating value of the gas to obtain the input to the burner in Btu per hour.

EXAMPLE: You measured the time for one complete revolution of dial is 72 seconds. The gas valve label says one full rotation equals 2 cu. ft. of gas. 3,600 divided by 72 is 50, 2 cubic foot was timed therefore  $50 \times 2$  is 100. Multiply 100 by a "heating value", which is 1,075 for natural gas; and this will give you an appliance input of 107,500 Btu/hr (31.51 Kw). Use a heating value of 2500 for LP gas.



The minimum gas supply pressure is 4.5" w.c. (1121Pa) for natural gas and 11.0" w.c. (2740Pa) for L.P. gas; failure to supply appropriate gas pressure may result in improper burning function and bad combustion.



Valve is rated for 0.5 PSI (14 inch w.c.). Over-pressurizing valve may cause damage to the valve.

## CHANGING THE ORIFICE

When leaving the factory each stock burner is sent out firing close to the minimum Btu/hr rating.

To increase the Btu/hr rating (increase the heating output) the orifice must either be changed or drilled out to the correct size. To determine drill bit size for required rate, see Table 4.

Each burner is sent out with two orifices. A blank orifice is hanging from the gas valve in a plastic bag. The second (minimum rate) orifice is installed in the burner in the orifice holder.

Before replacing the orifice, gas supply and power must be shut off. To replace the orifice locate and remove the two nuts that hold the orifice holder and gas pipe train to the back of the burner (Figure 7).

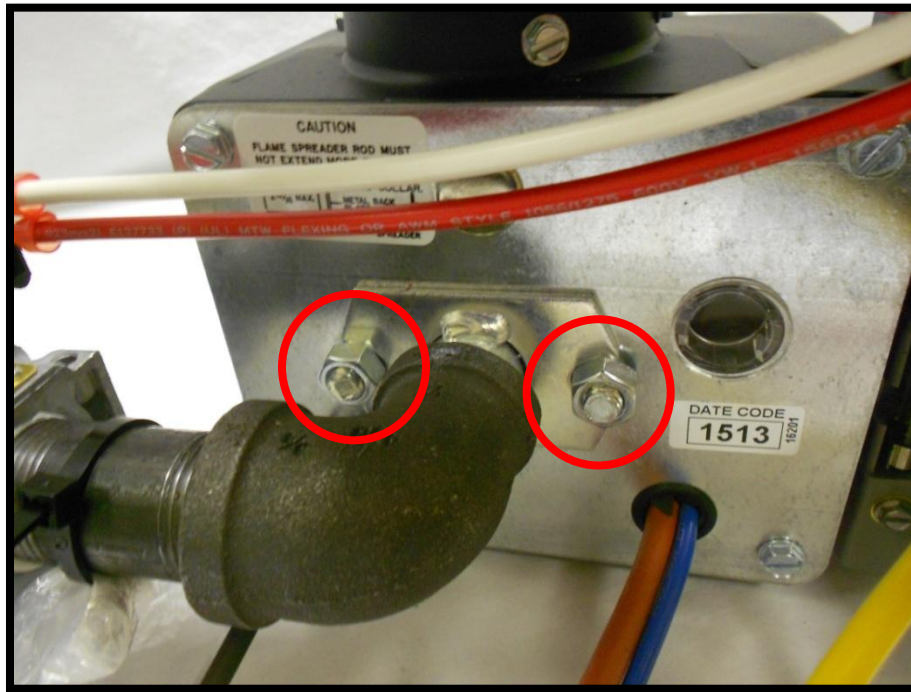

**FIGURE 7: ORIFICE HOLDER/GAS PIPE TRAIN NUT LOCATION**

**TIP:** Loosen one nut to the end of the stud but do not fully remove it. Remove second nut and then rotate off the gas train. This will help prevent the venturi from sliding down the air tube when reinstalling the gas train.

Pull the gas train out of the burner. The orifice is located on the end of the gas train and looks like a brass plug. Remove the orifice with a 11/16 inch wrench (Figure 8).

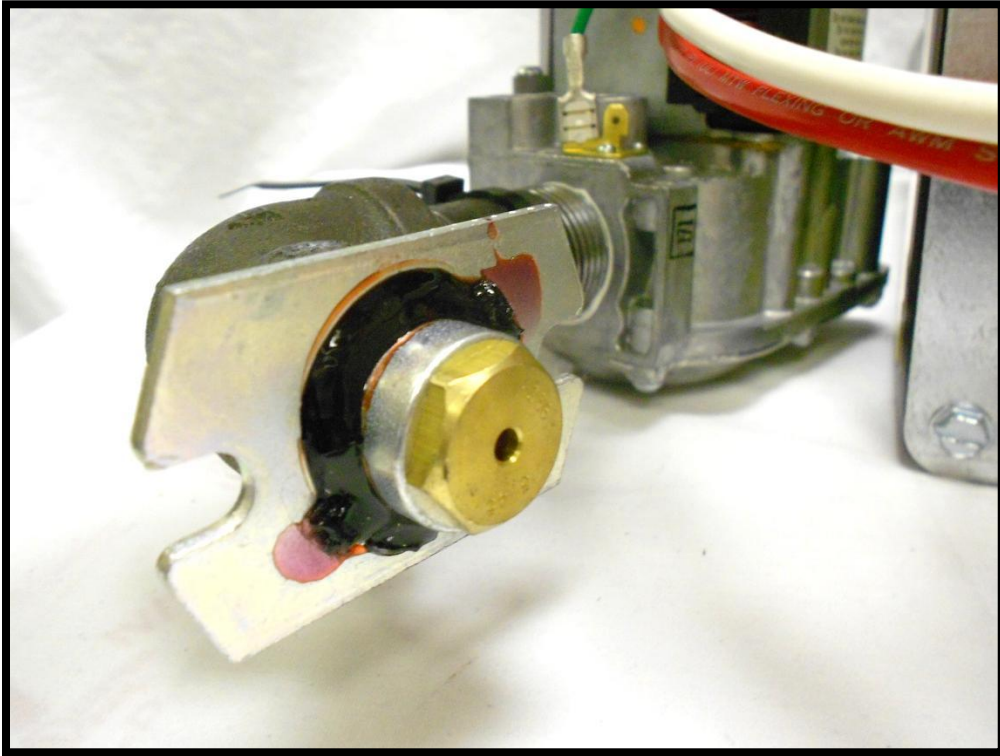

**FIGURE 8: ORIFICE LOCATION**

To drill the orifice, place it face down in a vice and drill through the back side. The back side is tapered and will make lining up the drill bit easier. Deburr the orifice and mark new size on orifice with permanent marker. Reinstall the orifice and secure the gas pipe train to the back of the burner using the nuts. **Record drilled orifice size in installation log in manual.**

NOTE: Numbered and lettered drill sizes are valid bit sizes. They are machinist's drill bits.

The burner is now ready to be connected to the gas supply piping; see instructions in next section.

## INSPECTION AND SIZING OF GAS PIPING



All piping must comply with local codes and ordinances or the National Fuel Gas Code ANSI Z223.1/NFPA No. 54.

A sediment trap or drip leg must be installed in the supply line to the burner. A union shall be installed in the gas line upstream from the control manifold and downstream from the sediment trap or drip leg (See Figure 10). A 1/8" NPT plugged tapping port accessible for test gauge connection shall be installed immediately upstream of the gas supply connection for the purpose of determining the gas supply pressure to the burner. A manual shutoff valve shall be installed in the gas supply line external to the appliance (See Figure 9).

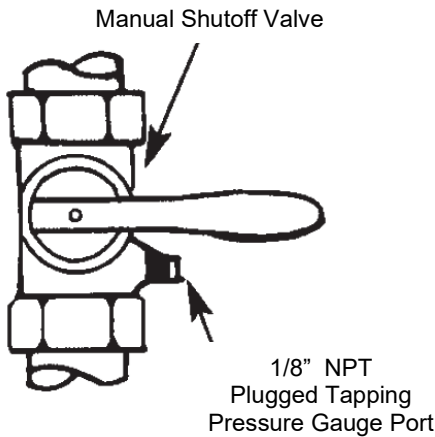

**FIGURE 9: MANUAL SHUT OFF VALVE AND PRESSURE TAP**

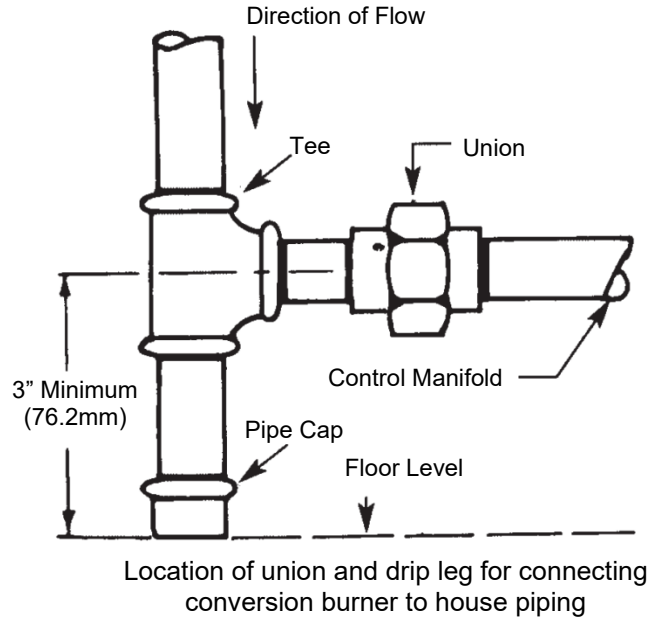

**FIGURE 10: PIPE UNION AND FITTINGS**

The gas line should be a separate supply direct from the meter to the burner. It is recommended that new pipe be used and located so that a minimum amount of work will be required in future servicing. The piping should be so installed as to be durable, substantial and gas tight. It should be clear and free from cutting burrs and defects in structure or threading. Aluminum tubing should not be used for the main gas supply. Joint compounds (pipe dope) should be used sparingly on male threads only and be approved for all gases.

2 Imperfect  
Threads

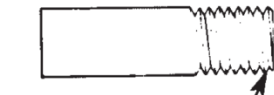
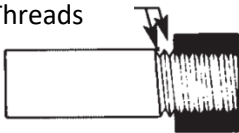

Leave 2 end  
threads bare

Pipe Size Inch (mm)	Effective Length of Thread Inch (mm)	Overall Length of Thread Inch (mm)
3/8 (9.525)	3/8 (9.525)	9/16 (14.29)
1/2 (12.7)	1/2 (12.7)	3/4 (19.05)
3/4 (19.05)	1/2 – 9/16 (14.29)	13/16 (20.64)
1 (25.4)	9/16 (14.29)	1 (25.4)

**FIGURE 11: PROPER PIPING PRACTICE**

It is recommended that tables 5, 6, and 7 be used to determine the size pipe to use from the meter to the burner. The building structure should not be weakened by installation for the gas piping. The piping should not be supported by the other piping, but should be firmly supported with pipe hooks, straps, bands or hangers. Butt or lap welded pipe should not be bent. **Note: Each elbow, union, and tee adds approximately 2.5 feet of pipe.**

The gas piping should be so installed so as to prevent an accumulation of condensation and it must be protected against freezing. A horizontal pipe should be pitched so that it grades toward the meter and is free from sags. The pipe should not be run through or in an

air duct or clothes chute. The appliance and its individual shutoff valve must be disconnected from the gas supply piping system during any pressure testing of the system at test pressure in excess of 1/2 psig (3447 PaG). The appliance must be isolated from the gas supply piping system by closing its individual manual shutoff valve during any pressure testing of the gas supply piping system at test pressures equal to or less than 1/2 psig (3447 PaG).

**Table 5: Pipe Sizing Chart for Natural Gas (0-0.5 psi) with Straight Schedule 40 Metal Pipe**  
 The following chart is based on **0-0.5 psi** inlet pressure, specific gravity of **0.6**, and a pressure loss of **0.5" w.c.**

<b>Maximum Capacity of Pipe Size in Btu per Hour</b>					
<b>Length of Pipe (ft)</b>	<b>1/2"</b>	<b>3/4"</b>	<b>1"</b>	<b>1 1/4"</b>	<b>1 1/2"</b>
<b>10</b>	175,000	360,000	680,000	1,400,000	2,100,000
<b>20</b>	120,000	250,000	465,000	950,000	1,460,000
<b>30</b>	97,000	200,000	375,000	770,000	1,180,000
<b>40</b>	82,000	170,000	320,000	660,000	990,000
<b>50</b>	73,000	151,000	285,000	580,000	900,000
<b>60</b>	66,000	138,000	260,000	530,000	810,000
<b>70</b>	61,000	125,000	240,000	490,000	750,000
<b>80</b>	57,000	118,000	220,000	460,000	690,000
<b>90</b>	53,000	110,000	205,000	430,000	650,000
<b>100</b>	50,000	103,000	195,000	400,000	620,000
<b>150</b>	40,000	84,000	160,000	325,000	500,000
<b>200</b>	35,000	72,000	135,000	280,000	430,000

**Table 6: Pipe Sizing Chart for Liquid Propane (11" w.c.) with Straight Schedule 40 Metal Pipe**  
 The following chart is based on **11" w.c.** inlet pressure and a pressure drop of **0.5" w.c.**

Special use: Piping sizing between single or second stage (low pressure regulator) and appliance.

<b>Maximum Capacity of Pipe Size in Btu per Hour</b>							
<b>Pipe Size</b>	<b>1/2"</b>	<b>3/4"</b>	<b>1"</b>	<b>1 1/4"</b>	<b>1 1/2"</b>	<b>2"</b>	<b>3"</b>
<b>Actual ID</b>	0.622	0.824	1.049	1.38	1.61	2.067	3.068
<b>Length of Pipe (feet)</b>	<b>Maximum Capacity in Btu/hr</b>						
<b>10</b>	291,000	608,000	1,145,000	2,352,000	3,523,000	6,786,000	19,119,000
<b>20</b>	200,000	418,000	787,000	1,616,000	2,422,000	4,664,000	13,141,000
<b>30</b>	160,000	336,000	632,000	1,298,000	1,945,000	3,745,000	10,552,000
<b>40</b>	137,000	287,000	541,000	1,111,000	1,664,000	3,205,000	9,031,000
<b>50</b>	122,000	255,000	480,000	984,000	1,475,000	2,841,000	8,004,000
<b>60</b>	110,000	231,000	434,000	892,000	1,337,000	2,574,000	7,253,000
<b>80</b>	94,000	197,000	372,000	763,000	1,144,000	2,203,000	6,207,000
<b>100</b>	84,000	175,000	330,000	677,000	1,014,000	1,952,000	5,501,000
<b>125</b>	74,000	155,000	292,000	600,000	899,000	1,730,000	4,876,000
<b>150</b>	67,000	140,000	265,000	543,000	814,000	1,568,000	4,418,000
<b>200</b>	58,000	120,000	227,000	465,000	697,000	1,342,000	3,781,000
<b>250</b>	51,000	107,000	201,000	412,000	618,000	1,189,000	3,351,000
<b>300</b>	46,000	97,000	182,000	373,000	560,000	1,078,000	3,036,000
<b>350</b>	42,000	89,000	167,000	344,000	515,000	991,000	2,793,000
<b>400</b>	40,000	83,000	136,000	320,000	479,000	922,000	2,599,000

**Table 7: Pipe Sizing Chart for Liquid Propane (11" w.c.) with Copper Tubing**

The following chart is based on 11" w.c. inlet pressure and a pressure drop of 0.5" w.c.

Maximum Capacity of Tube Size in Btu per Hour				
Pipe Size	1/2"	5/8"	3/4"	7/8"
Length (feet)	Maximum Capacity in Btu/hr			
10	110,000	206,000	348,000	536,000
20	76,000	141,000	239,000	368,000
30	61,000	114,000	192,000	296,000
40	52,000	97,000	164,000	253,000
50	46,000	86,000	146,000	224,000
60	42,000	78,000	132,000	203,000
70	38,000	71,000	120,000	185,000
80	36,000	67,000	113,000	174,000
90	33,000	62,000	105,000	161,000
100	32,000	59,000	100,000	154,000

**NOTE:** Copper tubing shall comply with standard type K or L of ASTM B 88 or ASTM B 280.

#### TESTING PIPING FOR LEAKS

Before turning gas under pressure into piping, all openings from which gas can escape should be closed. Immediately after turning on gas, the system should be checked for leaks. This can be done by watching the 1/2 cubic feet test dial and allowing 5 minutes to show any movement, or by soaping each pipe connection and watching for bubbles. If a leak is found, make the necessary repairs and repeat the above test. Defective pipes or fittings should be replaced and not repaired.



**Never use a flame** or fire in any form to locate gas leaks, use a soap solution.

After the piping and meter have been checked completely, purge the system of air. Do not bleed the air inside the furnace. Be sure to relight all the gas pilots on other appliances.

#### ELECTRICAL WIRING OF BURNER

The conversion burner is shipped completely wired. It is only necessary to supply the 115 volt circuit, thermostat and limit circuit. All wiring must conform with the National Electric Code or the code legally authorized in the locality where the installation is being made. The burner, when installed, must be electrically grounded in accordance with local codes or, in the absence of local codes, with the latest edition of the National Electrical Code, ANSI/NFPA No. 70. See wiring diagrams in Figure 23 through Figure 28 for reference on wiring, thermostat connection, and limit circuit. If an external electrical source is utilized, the conversion burner, when installed, must be electrically grounded in accordance with local codes or, in the absence of local codes, with the latest edition of the National Electrical Code ANSI/NFPA No. 70.

The burner ships with a jumper wire on the thermostat (T-T) terminals. Jumper needs to be removed for remote thermostat control and the thermostat needs to be connected per wiring diagrams. T-T terminal is an open/close switch for the burner and no voltage should be connected to it. For boilers it may be necessary to leave the T-T terminal jumped as the aquastat may be providing the voltage to the burner and controlling when voltage is sent to the burner. The burner is controlled by the appliance. Once wiring is complete between burner and appliance, verify appliance is controlling the burners on/off operation. When connecting the burner to the 120 volt electrical supply, utilize the knockout provided on the burner's junction box (Non -E Series only) or enclosure box (-E Series only).

Label all wires prior to disconnection when servicing controls. Wiring errors can cause improper and dangerous operation. Verify proper operation after servicing.

## INSPECTION OF LIMIT CONTROL SWITCHES

Warm air furnaces (gravity and forced air) should be equipped with an automatic temperature limit control switch. Hot water boilers (forced or gravity) should be equipped with an automatic temperature limit control switch. Steam or vapor boilers be provided with means to guard against firing a dry boiler or one in which the water is dangerously low.



On installations where an oil burner is being replaced with a gas burner, the controls on the boiler or furnace will have to be checked for compatibility with the gas burner. All controls should be checked to ensure that they operate properly and that they are in good condition. In no case should any limit or safety control be bypassed or wired in such a manner that it will result in unsafe operation of the burner or appliance. If the controls on the appliance are not compatible with the burner operation they should be replaced with the proper controls.

## INSTALLATION OF THERMOSTAT

The thermostat should be installed on an inside wall and should be located in the natural circulating path of room air. Locations which would expose the thermostat to cold air, or drafts from windows, door, or openings leading to the outside, or to air currents from cold or warm air registers, or where the natural circulation of air is shut off such as behind doors, above or below mantels, shelves or in corners, should be avoided. The thermostat should not be exposed to heat from nearby radiators, lamps, rays of the sun or mounted on a wall near pipes, warm air ducts or chimney flue. Any hole in the plaster or panel through which the thermostat wires pass should be sealed to prevent drafts. The maximum comfort to be obtained from any automatic heating installation is dependent to a great extent upon the proper installation and adjustment of the room thermostat.

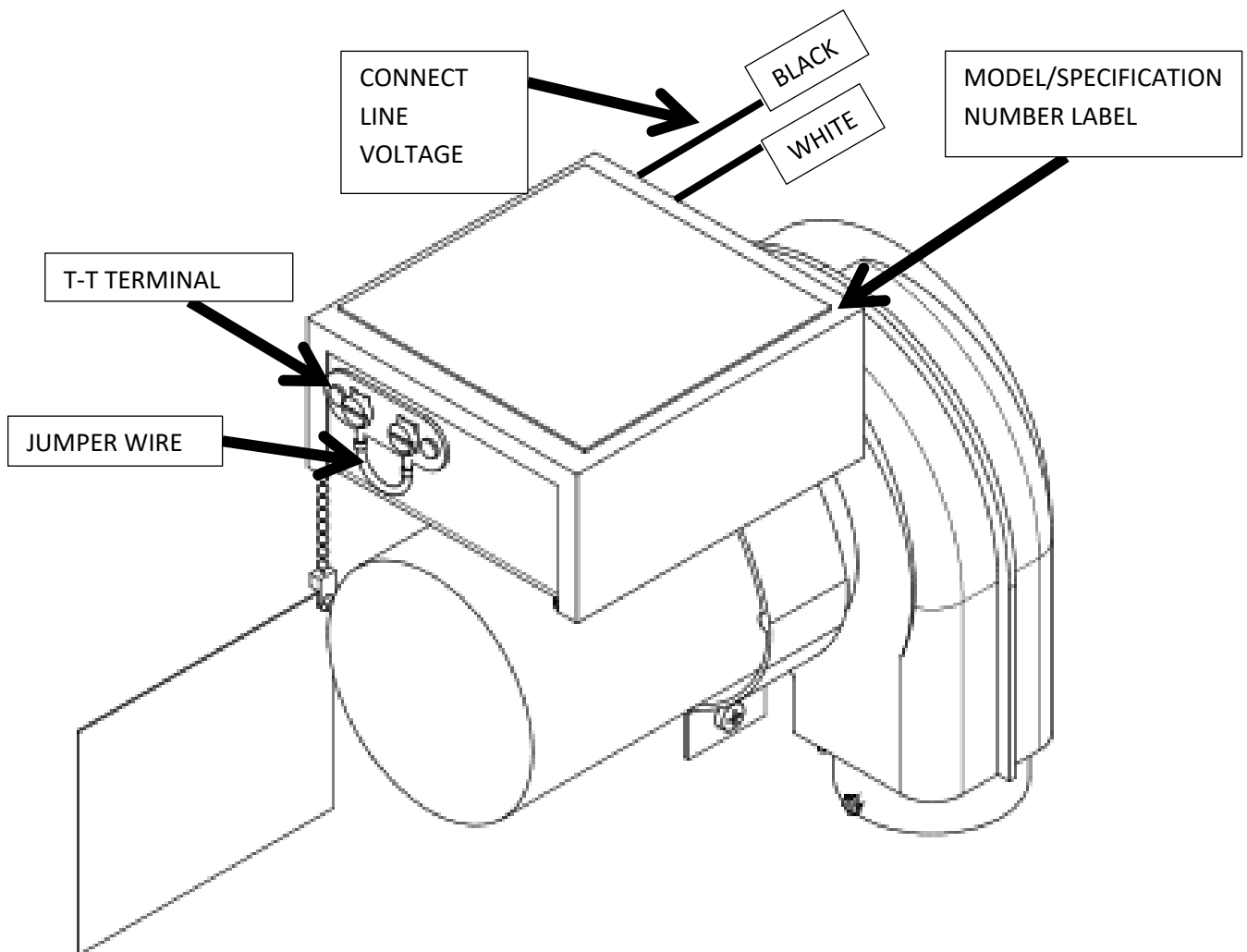
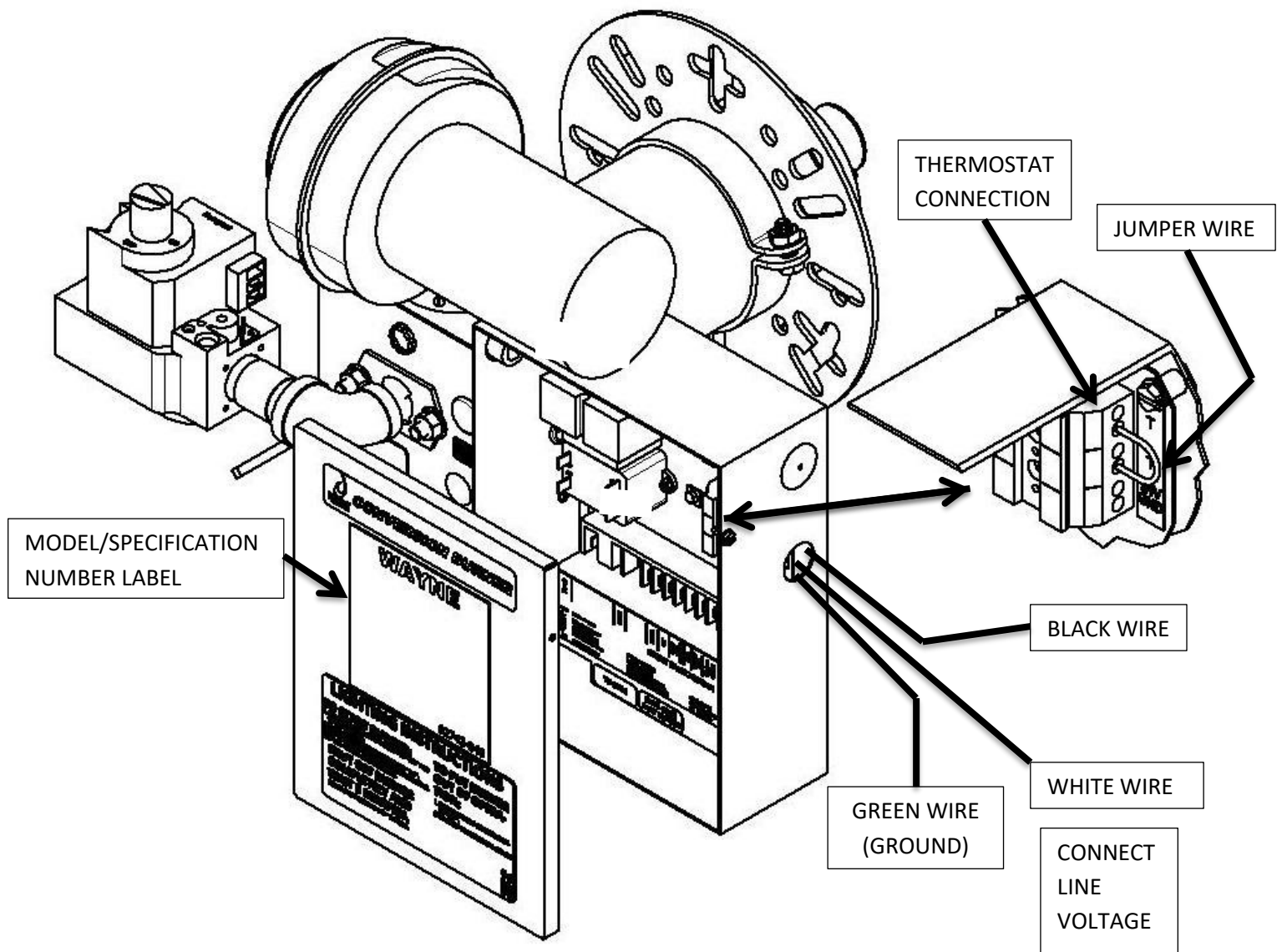

FIGURE 12: T-T TERMINAL LOCATION (Non -E Series)



**FIGURE 13: THERMOSTAT CONNECTION LOCATION (-E Series)**

## SECTION II: INITIAL START UP

### OPERATION OF BURNER (DIRECT SPARK IGNITION)

Starting the Burner:

1. Depress the gas valve control knob on the combination gas valve and turn to "OFF" (See Figure 13).
2. Set the room thermostat above room temperature and let the burner run five minutes to purge the appliance.
3. Set thermostat below room temperature.
4. Turn gas control valve knob to "ON".
5. Set room thermostat higher than room temperature so that the burner will start.

To put burner out of operation

1. Depress the gas valve control knob on the combination gas valve and turn to "OFF".
2. Turn off electrical supply.

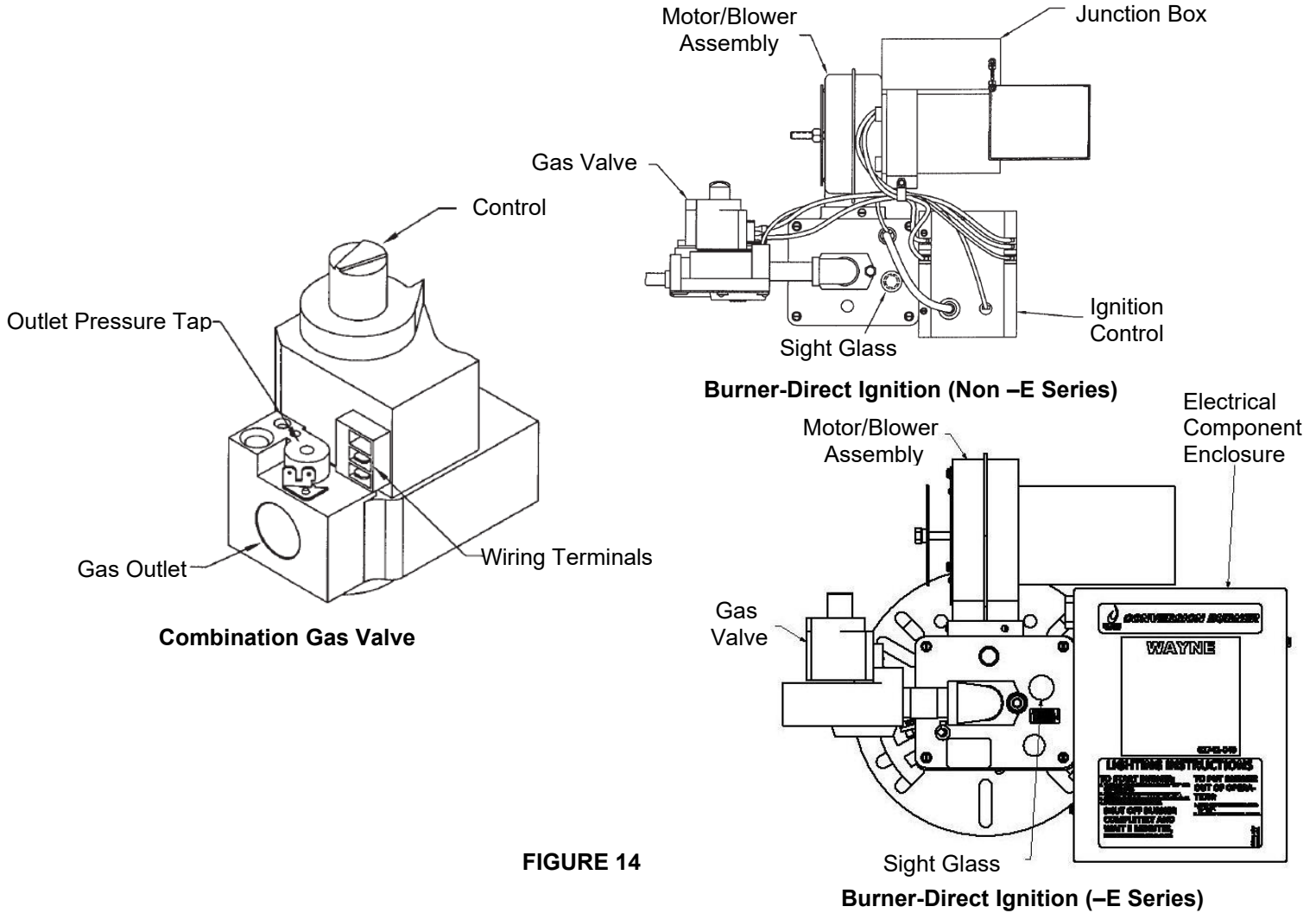

FIGURE 14

**BURNER OPERATION (Honeywell S87K Ignition Control)**

On every call for heat (system start), the ignition control performs a 30 second pre-purge. Upon completion of the pre-purge, the ignition control opens the gas valve operator in the gas control. This allows gas to flow to the burner. Simultaneously, the electronic spark generator in the control produces a spark pulse output. This voltage produces a spark at the burner igniter-sensor rod, igniting the gas flowing around the electrode. If flame is not detected during the trial for ignition, the ignition control will go into a "lock-out" condition. If this occurs, proceed to the section titled SAFETY LOCK-OUT TIME (Honeywell S87K Ignition Control).

**BURNER OPERATION (Wayne or Fenwal Ignition Controls)**

On every call for heat (system start), the ignition control performs a 30 second pre-purge. Upon completion of the pre-purge, the ignition control opens the gas valve operator in the gas control. This allows gas to flow to the burner. Simultaneously, the electronic spark generator in the control produces a spark pulse output. This voltage produces a spark at the burner igniter-sensor rod, igniting the gas flowing around the electrode. If flame is not detected during the trial for ignition, the ignition control will wait for the 30 second interpurge time, and will then perform another trial for ignition. If flame is not detected again during the trial for ignition, the control will wait for one last 30 second interpurge and then will perform one last trial for ignition. If during the third trial for ignition, no flame is detected the ignition control will go into a "lock-out" condition. If this occurs, proceed to the section titled SAFETY LOCK-OUT TIME (Wayne or Fenwal Ignition Control).

**SAFETY LOCK-OUT TIME (Honeywell S87K Ignition Control)**

The trial for ignition timer circuit starts timing the moment the trial for ignition starts. If the designated trial for ignition time expires prior to the detection of a flame, the ignition control will go into a "lock-out" condition. Before another attempt to start the burner can be made, the ignition control must be reset. Reset by adjusting the thermostat or controller below room temperature, or to its "OFF" position. An alternate method is to shut the system power "OFF". Wait at least one (1) minute and then turn the system "ON". If normal ignition does not occur, use Section V: Servicing and Troubleshooting to determine the problem.

**SAFETY LOCK-OUT TIME (Wayne or Fenwal Ignition Control)**

The trial for ignition timer circuit starts timing the moment the trial for ignition starts. If the designated trial for ignition time expires prior to the detection of a flame three times with an interpurge between each trial, then the ignition control will go into a "lock-out" condition. Before another attempt to start the burner can be made, the ignition control must be reset. Reset by adjusting the thermostat or controller below room temperature, or to its "OFF" position. An alternate method is to shut the system power "OFF". Wait at least one (1) minute and then turn the system "ON". If normal ignition does not occur, use Section V: Servicing and Troubleshooting to determine the problem.

## OPERATION OF BURNER (ELECTRONIC PILOT) (P265-EP, P265F-EP, P250AF-EP)

Starting the Burner:

1. Depress the gas valve control knob on the combination gas valve and turn to "OFF" (See Figure 15).
2. Set room thermostat above room temperature and let burner run five minutes to purge the appliance.
3. Set thermostat below room temperature.
4. Turn gas valve control to "ON".
5. Set room thermostat higher than room temperature so that the burner will start.

To put burner out of operation

1. Depress the gas valve control knob on the combination gas valve and turn to "OFF".
2. Turn off electrical supply.

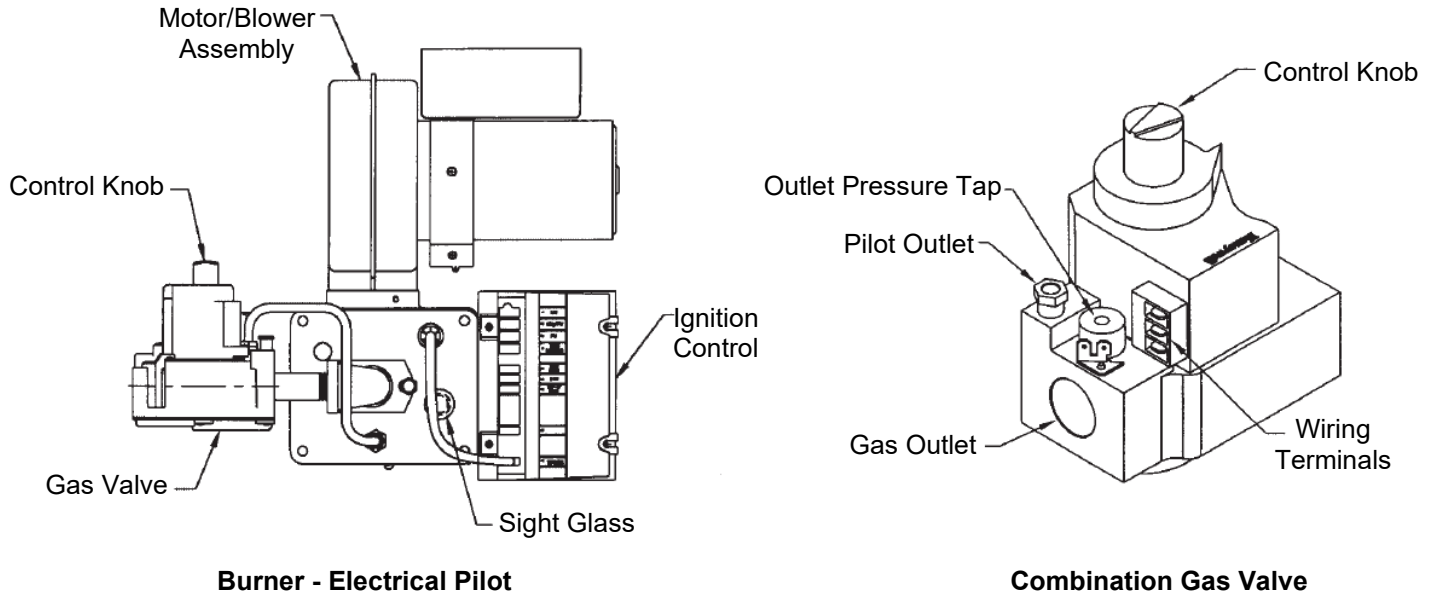

**FIGURE 15**

### **FIRST STAGE – TRIAL FOR PILOT IGNITION (Fenwal Ignition Control)**

On every call for heat (system start), ignition control performs a self-check routine, flashes the diagnostic LED and moves to trial for ignition. During the trial for ignition the pilot gas valve is energized and sparking commences. The main gas valve remains de-energized until the pilot flame is detected. Should pilot fail to light or the pilot flame is not detected the pilot valve will de-energize and the ignition control goes through an inter-purge delay. After the inter-purge delay, the ignition control will try an additional ignition attempt and if no flame is detected it will repeat the inter-purge delay one more time before trying a final time for ignition. If no flame is detected on the final trial, then the pilot gas valve will de-energize and control will go into a "lock-out" condition. If this occurs, proceed to the section titled SAFETY LOCK-OUT TIME (Fenwal).

### **FIRST STAGE – TRIAL FOR PILOT IGNITION (Honeywell Ignition Control)**

On every call for heat (system start), the ignition control performs a 30 second pre-purge. Upon completion of the pre-purge, the ignition control opens the pilot gas valve operator in the gas control. This allows gas to flow to the pilot burner. Simultaneously, the electronic spark generator in the S8600 produces a 15,000 volt spark pulse output. This voltage produces a spark at the pilot burner igniter-sensor rod, igniting the gas flowing around the electrode. If the pilot flame is not detected during the trial for pilot ignition, the ignition control will go into a "lock-out" condition. If this occurs, proceed to the section titled SAFETY LOCK-OUT TIME (Honeywell).

### **SECOND STAGE – MAIN BURNER OPERATION (Honeywell and Fenwal Ignition Controls)**

When the pilot flame is established the ignition control's flame sensing circuit detects the flame current and shuts the spark generator off. At the same time the main gas valve operator is opened in the gas control, allowing gas flow to the main burner. The pilot flame ignites the main burner conventionally.

### **SAFETY LOCK-OUT TIME (Fenwal)**

The trial for ignition timer circuit starts timing the moment the trial for pilot ignition starts. If the designated trial for ignition time expires prior to the detection of a pilot flame, the ignition control will try two additional ignition trials after an inter-purge delay before each trial. If no flame is detected after three trials for ignition, the control will go into a "lock-out" condition. Before another attempt to start the burner can be made, the ignition control must be reset. Reset by adjusting the thermostat or controller below room temperature, or to its "OFF" position. An alternate method is to shut the system power "OFF". Wait at least one (1) minute and then turn the system "ON". If normal ignition does not occur, use Section V: Servicing and Troubleshooting to determine the problem.

### SAFETY LOCK-OUT TIME (Honeywell)

The trial for ignition timer circuit starts timing the moment the trial for pilot ignition starts. If the designated trial for ignition time expires prior to the detection of a pilot flame, the ignition control will go into a "lock-out" condition. Before another attempt to start the burner can be made, the ignition control must be reset. Reset by adjusting the thermostat or controller below room temperature, or to its "OFF" position. An alternate method is to shut the system power "OFF". Wait at least one (1) minute and then turn the system "ON". If normal ignition does not occur, use Section V: Servicing and Troubleshooting to determine the problem.

### OPERATION OF BURNER (STANDING PILOT)

Starting the Burner:

1. Depress the gas valve control knob on the combination gas valve and turn to "OFF" (See Figure 16).
2. Set room thermostat above room temperature and let burner run five minutes to purge the appliance.
3. Set thermostat below room temperature.
4. Turn gas valve control to "PILOT".
5. Depress red button on valve to start pilot gas flow.
6. Push red button down on spark igniter until it snaps. Repeat this until the pilot lights. Note: this may take some time until all the air is "bled" out of the line. The pilot can be seen by looking through the sight glass.
7. Hold the red button on the valve for 60 seconds, then release.
8. Observe pilot – if not lit, SHUT OFF BURNER COMPLETELY AND WAIT 5 MINUTES. Repeat steps 1 through 7.
9. Turn gas control valves to "ON".
10. Set room thermostat higher than room temperature so that the burner will start.

To put burner out of operation

1. Depress the gas valve control knob on the combination gas valve and turn to "OFF".
2. Turn off electrical supply.

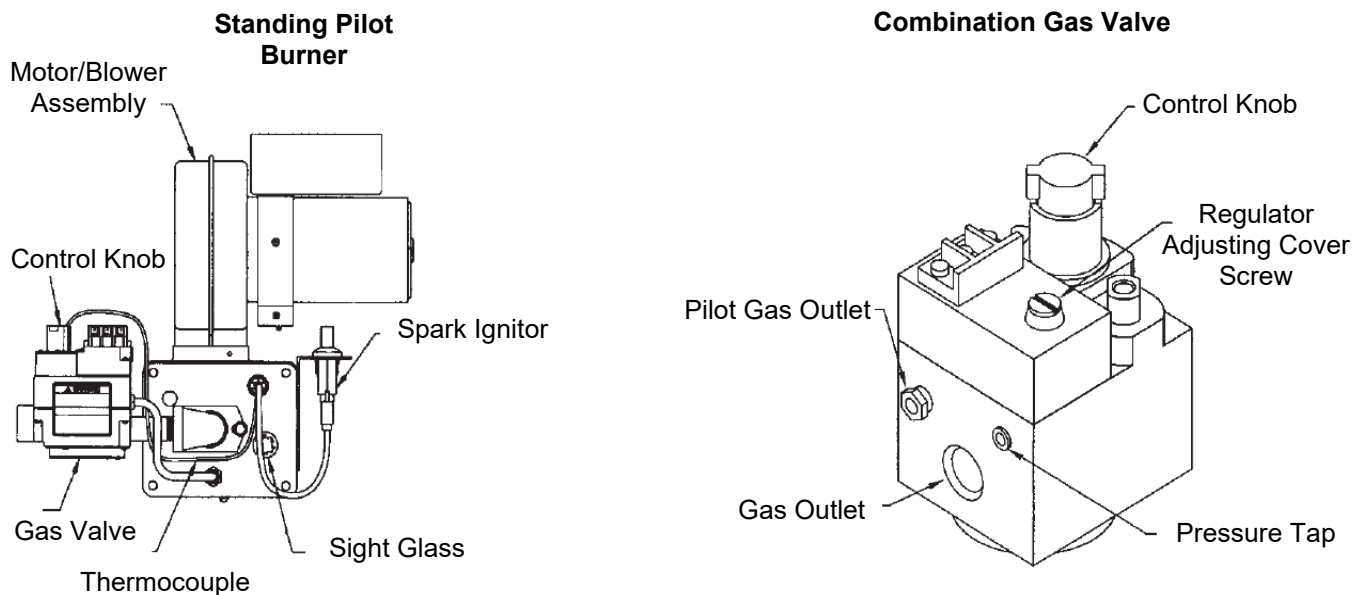

FIGURE 16

## COMBUSTION ADJUSTMENT OF BURNER

All adjustments below must be made with the following equipment:

1. Draft Gauge
2. O<sub>2</sub> or CO<sub>2</sub> Analyzer
3. CO Tester
4. Water Column Gauge

### Flame Spreader Adjustment (P250AF Only)

The flame spreader is used to shape the flame to best suit the firing chamber. Depending on the firing chamber, the flame spreader can be used to produce a long narrow flame or a short bushy flame.

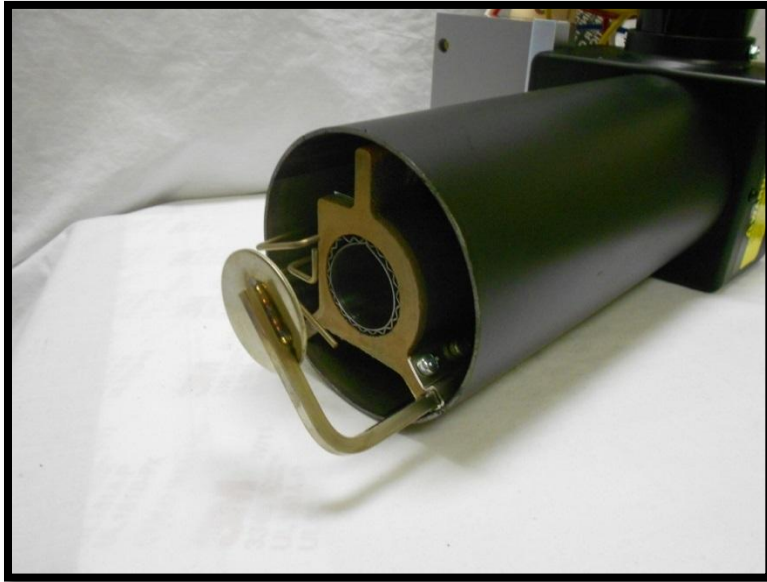

**FIGURE 17: FLAME SPREADER LOCATION**

To adjust the flame spreader on a P250AF burner, first loosen the set screw located on the back of burner near the bottom using a 3/32 inch Allen wrench.

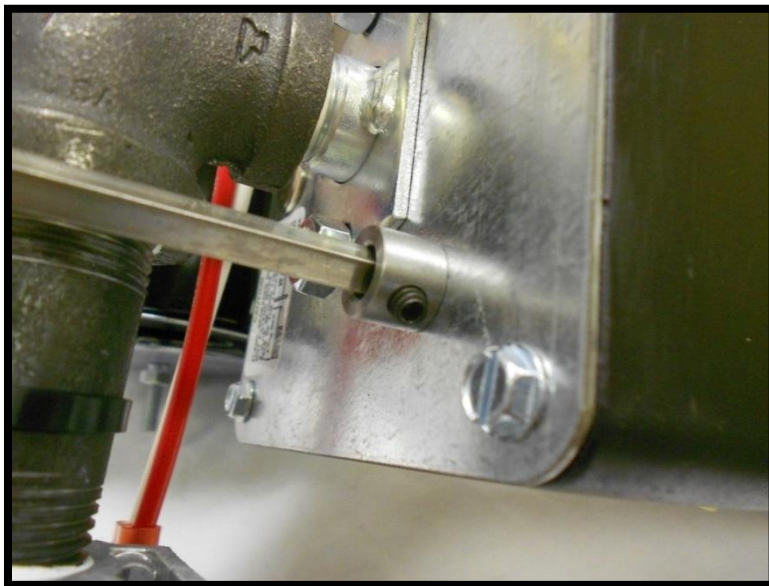

**FIGURE 18: FLAME SPREADER SET SCREW LOCATION**

With the flame spreader pulled all the way back, the flame spreader adjustment rod should measure approximately 3 1/4 inches from the back plate. With the flame spreader adjustment rod pushed all the way in it should measure approximately 1 inch from the burner back plate.

Adjust the flame so that it will fill the firebox without impinging on the back wall.

Once the flame is adjusted properly, retighten the set screw.

#### Air Shutter Adjustment

To adjust the disc air shutter, loosen the locking nut and then spin the disc either closer to or further from the fan housing. Increasing the air shutter opening will usually lower the CO<sub>2</sub> and CO readings. To determine the correct air shutter adjustment a combustion analyzer capable of measuring CO<sub>2</sub> (or O<sub>2</sub>) and CO must be used.

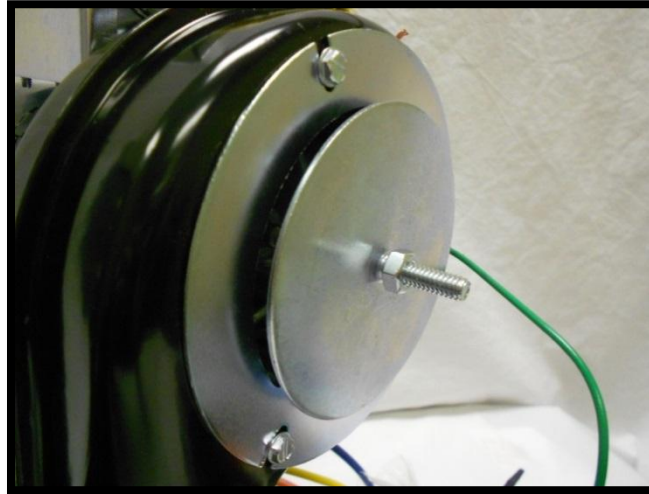

**FIGURE 19: AIR SHUTTER LOCK NUT LOCATION**

For natural gas applications, best performance will be achieved with a CO<sub>2</sub> setting of 8% to 10% (3% to 6.5% O<sub>2</sub>) and CO should be minimized with a goal of 100 ppm or less. **In no case should CO be above 400 ppm.**

For propane gas applications, best performance will be achieved with a CO<sub>2</sub> setting of 9.5% to 11.8% (3% to 6.5% O<sub>2</sub>) and CO should be minimized with a goal of 100 ppm or less. **In no case should CO be above 400 ppm.**

Stack temperatures for furnaces and boilers are recommended to be between 350 and 400 degrees Fahrenheit. Tighten the lock nut to secure the air shutter. After the air is adjusted and the burner is running properly, be sure to record all set up information and leave it with the burner.

#### **FINAL INSTALLATION INSTRUCTIONS**

Once adjustments to the burner are complete and burner is set up per the manual, record combustion numbers measured during setup, burner model number, model specification number, inlet gas pressure, date of installation, and contractor contact information in Installation Log. Leave the manual with appliance.

## SECTION III: GAS CONVERSION

### NATURAL GAS AND LP CONVERSION INSTRUCTIONS FOR P250 AND P265 BURNERS

In order to allow P250 and P265 burners to be converted from natural gas to LP gas operation, or from LP to natural gas operation, Wayne Combustion Systems has created gas conversion kits that contain all the parts necessary for any burner model regardless of the type of ignition system utilized; Direct Ignition, Electronic Pilot Ignition, Standing Pilot Ignition. The part numbers for these kits are as follows:

- 62955-001      Kit for converting natural gas burners to LP gas.  
62956-001      Kit for converting LP gas burners to natural gas.

In addition to the necessary parts to complete the gas conversion, each kit contains detailed instructions for the conversion. To order the appropriate gas conversion kit, please contact a local wholesaler. The Wayne Combustion Customer Service Department can assist in locating the nearest wholesaler.

The conversion will require drilling a new gas orifice, changing the regulator spring in the gas valve and properly adjusting the gas pressure, applying new labels to the burner, and in the case of burners with either Electronic Pilot (EP) or Standing Pilot Ignition systems, a change to the pilot orifice. In order to assist with the planning of a conversion from natural to LP gas, or LP gas to natural, a list of necessary tools/equipment is shown below:

#### Equipment (Both Kits):

- |                                  |  |                              |
|----------------------------------|--|------------------------------|
| 1. Slack tube manometer          | 7. 1/8" Diameter clear or rubber tubing        | 13. Drill Index (drill bits) |
| 2. 1/4" Flat head screw driver   | 8. An Instrument to measure CO <sub>2</sub> -% | 14. Drill                    |
| 3. 3/16" Allen wrench            | 9. An Instrument to measure CO-ppm             | 15. Conversion kit.          |
| 4. 1/2" Open end wrench          | 10. Orifice chart *                            | 16. Soapy water bottle       |
| 5. 11/16" Open end wrench        | 11. Stop watch                                 | 17. Two 10" pipe wrenches    |
| 6. 1/8" NPT brass barbed fitting | 12. Burner manual                              | 18. 7/16" Open end wrench    |

To complete the conversion, follow the directions provided with the kit.

## SECTION IV: CONSUMER INSTRUCTIONS

### GENERAL INSTRUCTIONS FOR SERVICING BURNER

Gas burners require the services of an experienced technician for proper setting and adjustment. If the burner does not appear to be operating properly, **DO NOT ATTEMPT TO ADJUST THE BURNER YOURSELF**, but call in a competent serviceman. A homeowner should be able to check several possible causes of shutdown before calling in a serviceman. The following check list may eliminate the need for a service call or at least provide information for the serviceman.

1. Check thermostat. Make sure that it is set at the desired room temperature. If the thermostat is damaged or loose on the wall, have it replaced or repaired.
2. Check fuses in service box for the burner circuit. Replaceable type fuses should not be loose in the socket. If a fuse is blown out or if in doubt, replace with the same size and type. If circuit breaker is in the service box, check position of indicator. If tripped, reset.
3. Check on-off switch for the burner circuit, it may have been accidentally turned off.
4. With the thermostat set 10 degrees above room temperature, the burner should start automatically. If it does not start, check pilot. If no flame is visible, relight pilot following lighting instructions. Burners with the letters DI (Direct Ignition) and EP (Electrical Pilot) do not have continuously burning pilots.

**It is advisable, periodically, to visually inspect the burner. Check air inlet blower to make sure it is not clogged or blocked. Check air shutter to make sure that it has not been tampered with, make sure that it is in the same position as when final adjustments were made. Check blower wheel to see if it is dirty or full of lint. Open observation door and check pilot flame. If the flame does not appear normal or if in doubt, call a serviceman.** The areas around the conversion burner should be kept clear and free of combustible materials, gasoline and other flammable vapors and liquids. The flow of combustion and ventilating air to the burner must not be blocked or obstructed in any manner.

**CLEANING OF BURNERS (BY SERVICEMAN ONLY):** Remove the burner from the appliance and visually inspect the blast tube for any deterioration. On burners equipped with standing pilot or electronically ignited pilots, inspect pilot burner for dust or corrosion and clean if necessary. Check pilots, thermo-couples, electrodes, etc. with illustrations in the owner's manual for proper locations. Check flame spreaders if applicable for any deterioration and replace if necessary. Remove corrugated flame ring from the end of the venturi and clean. Visually inspect the inside of the venturi for any excessive rust or corrosion and clean if necessary. Replace corrugated flame ring and reinstall burner.

## SECTION V: SERVICE AND TROUBLESHOOTING

### NORMAL OPERATION CHECK OF BURNER (DIRECT IGNITION)

1. APPLIANCE CALLS FOR HEAT BY RAISING THE THERMOSTAT TO THE DESIRED SETTING: Note the transformer is always energized with 110 volts.
2. When the thermostat circuit is complete, this allows 24 volts to coil side of the fan relay which are the bottom terminals.
3. Now that 24 volts (yellow wires) are applied to the coil, this in turn allows the 115 volt contacts to close thus allowing 115 volts to flow to the fan across terminals #2 and #4 which are in series with the fan motor.
4. The combustion fan motor should now be energized.
5. With the fan energized, there will be a 30 second pre-purge.
6. The fan motor will develop 3400 rpm quickly causing the centrifugal end switch to close. The end switch can be identified by the two red wires coming from the end cap of the fan motor.
7. After the end switch makes, this allows 24 volts to the direct ignition control.
8. Now the ignition process will follow.
9. The direct ignition control will generate a high frequency spark at the same time the gas valve opens.

The **Wayne ignition control** has a 4 second trial for ignition period and has three trials for ignition. If after four seconds the control does not sense a minimum flame signal of 0.08 micro amps then the control will wait for a 30 second interpurge and then perform a second trial for ignition. If the Wayne ignition control does sense a minimum flame signal of 0.08 microamps then the control will wait another 30 seconds for an interpurge. The Wayne ignition control will then have one last trial for ignition and if the ignition control does not see a minimum flame signal of 0.08 microamps then the control will go into lockout.

The **Honeywell S87K ignition control** has a 4 second trial for ignition period. If after four seconds the control does not sense a minimum flame signal of 0.8 microamps then the control will go into lockout.

The **Fenwal ignition control** has a 4 second trial for ignition period and has three trials for ignition. If after four seconds the control does not sense a minimum flame signal of 0.8 micro amps then the control will wait for a 30 second interpurge and then perform a second trial for ignition. If the Fenwal ignition control does sense a minimum flame signal of 0.8 microamps then the control will wait another 30 seconds for an interpurge. The Fenwal ignition control will then have one last trial for ignition and if the ignition control does not see a minimum flame signal of 0.8 microamps then the control will go into lockout.

To reset the control simply cycle the thermostat off and then set it to the desired room temperature.

10. After the burner is operational, the control shifts into a rectification mode constantly monitoring the flame signal.
11. The burner will now cycle off and on based on the thermostat setting.

## NORMAL OPERATION CHECK OF BURNER (ELECTRONIC PILOT-Fenwal)

### PRELIMINARY CHECK

The following visual checks should be made before troubleshooting an after installation or maintenance.

1. Check the power to the appliance and Fenwal ignition control.
2. Manual shutoff cocks in gas line to appliance must be open.
3. Make certain all wiring connections are clean and tight.
4. Fenwal module must not be in safety lockout. First de-energize the system and wait at least one (1) minute. This resets the module, allowing a return to start condition.
5. Review the Fenwal system normal sequence of operation in Figure 20 below.

### SEQUENCE OF OPERATION

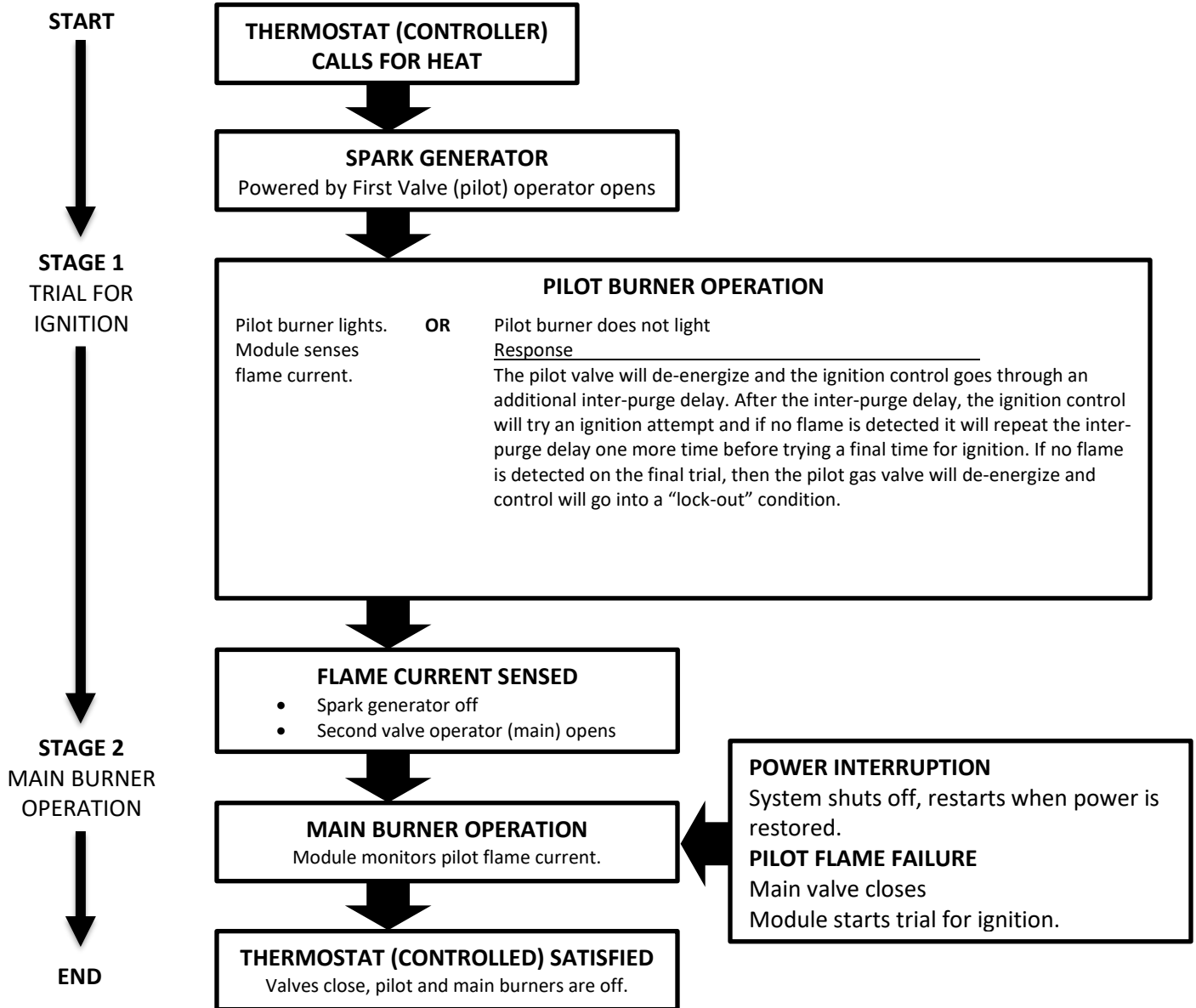

**FIGURE 20**

## NORMAL OPERATION CHECK OF BURNER (ELECTRONIC PILOT-Honeywell)

### PRELIMINARY CHECK

The following visual checks should be made before troubleshooting an after installation or maintenance.

1. Check the power to the appliance and S8600.
2. Manual shutoff cocks in gas line to appliance must be open.
3. Make certain all wiring connections are clean and tight.
4. S86G, H module must not be in safety lockout. First de-energize the system and wait at least one (1) minute. This resets the module, allowing a return to start condition.
5. Review the S8600 system normal sequence of operation in Figure 21 below.

### SEQUENCE OF OPERATION

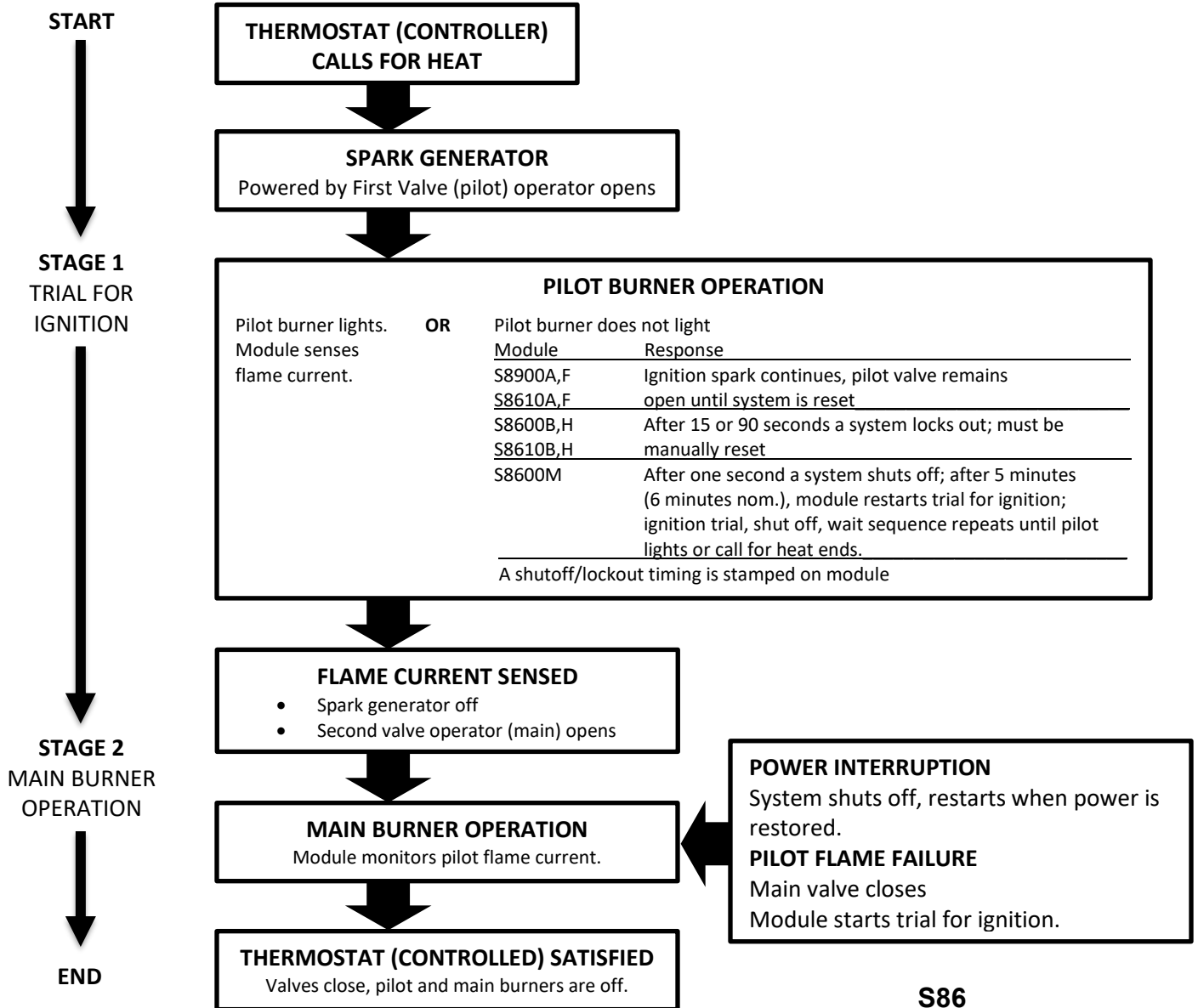

**FIGURE 21**

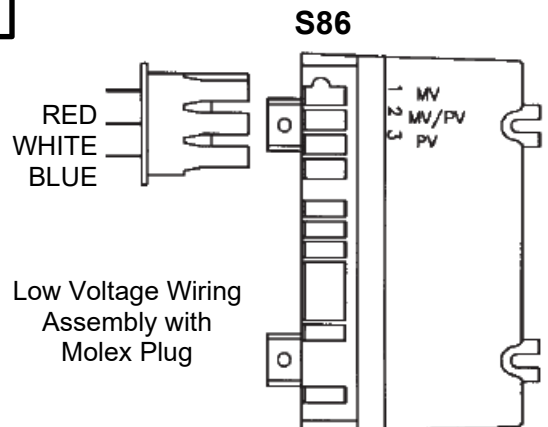

## TROUBLESHOOTING GUIDE DIRECT IGNITION

NOTE 1: BURNERS ARE NOT PRESET FROM THE FACTORY AND MUST BE ADJUSTED AT THE SITE.

NOTE 2: NEW GAS LINE INSTALLATIONS WILL HAVE AIR IN THE LINES AND REQUIRE SEVERAL IGNITION ATTEMPTS TO PURGE ALL THE AIR FROM THE LINES.

NOTE 3: DO NOT ATTEMPT TO PERFORM ANY WORK ON THIS BURNER UNLESS THE FOLLOWING TOOLS ARE AVAILABLE AND YOU ARE A CERTIFIED INSTALLER:

1. VOLT METER-VOLTS, OHMS, CONTINUITY
2. AMP METER-CLAMP TYPE
3. BURNER MANUAL
4. MANOMETER
5. O<sub>2</sub> OR CO<sub>2</sub> ANALYZER
6. CO TESTER
7. BLADE SCREW DRIVERS
8. NUT DRIVERS
9. OPEN END WRENCHS
10. TAPE MEASURE

The Wayne Burner that you are attempting to troubleshoot has the following electrical single phase components:

1. 115 Volt Combustion Fan Motor with End Switch
2. Fan Relay-24 Volt Coil Side and 110 Volt Fan Side
3. Honeywell or Wayne or Fenwal Gas Primary Control (24 volt)
4. Honeywell Gas Valve (24 volt)
5. Transformer- 115 Volt Side and 24 Volt Side
6. Ignition Rod/Sensing Rod
7. Ignition Lead
8. T-T (24 volt) Terminal
9. Terminal Blocks (Only -E Series)

### TROUBLESHOOTING TERMINAL BLOCKS (-E SERIES ONLY)

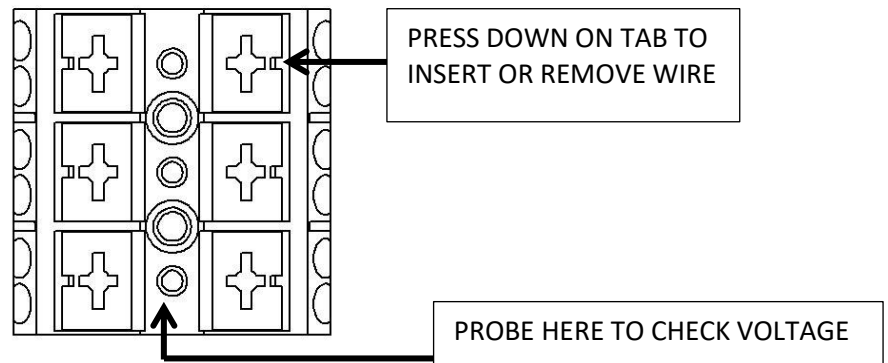

Figure 22: -E Series Terminal Block Electrical Information

Connecting to Terminal Blocks:

To connect a wire to the terminal block, strip  $\frac{1}{4}$ " of insulation from the end of the wire, then insert it into one of the connection holes while applying firm pressure on the tab nearest to it. Release the tab when the wire is in, and then tug the wire to confirm a good connection. Voltage may be tested at each node by probing the holes between the tabs.

## TROUBLESHOOTING GUIDE ELECTRONIC PILOT (FOR BURNERS UTILIZING HONEYWELL S8600 OR FENWAL IGNITION CONTROL)

Start the system by setting the thermostat or controller above required temperature. Observe system response. Establish type of malfunction or deviation from normal operation. Use Figure 23 to check for normal system operation by following instruction question in box. If the condition is true or okay (answers yes), go down to next box underneath, if the condition is not true or not okay (answers no), go right to the next box alongside. Continue checking and answering conditions in each box encountered, until a problem and/or the repair are explained. After any maintenance or repair, the troubleshooting sequence should be repeated until the troubleshooting procedure ends with normal system operation.

**IMPORTANT:** The electronic Control Module cannot be repaired. If troubleshooting procedure indicates a malfunction in the Control Module, it must be replaced. Intermittent pilot systems should be serviced only by trained and experienced personnel.

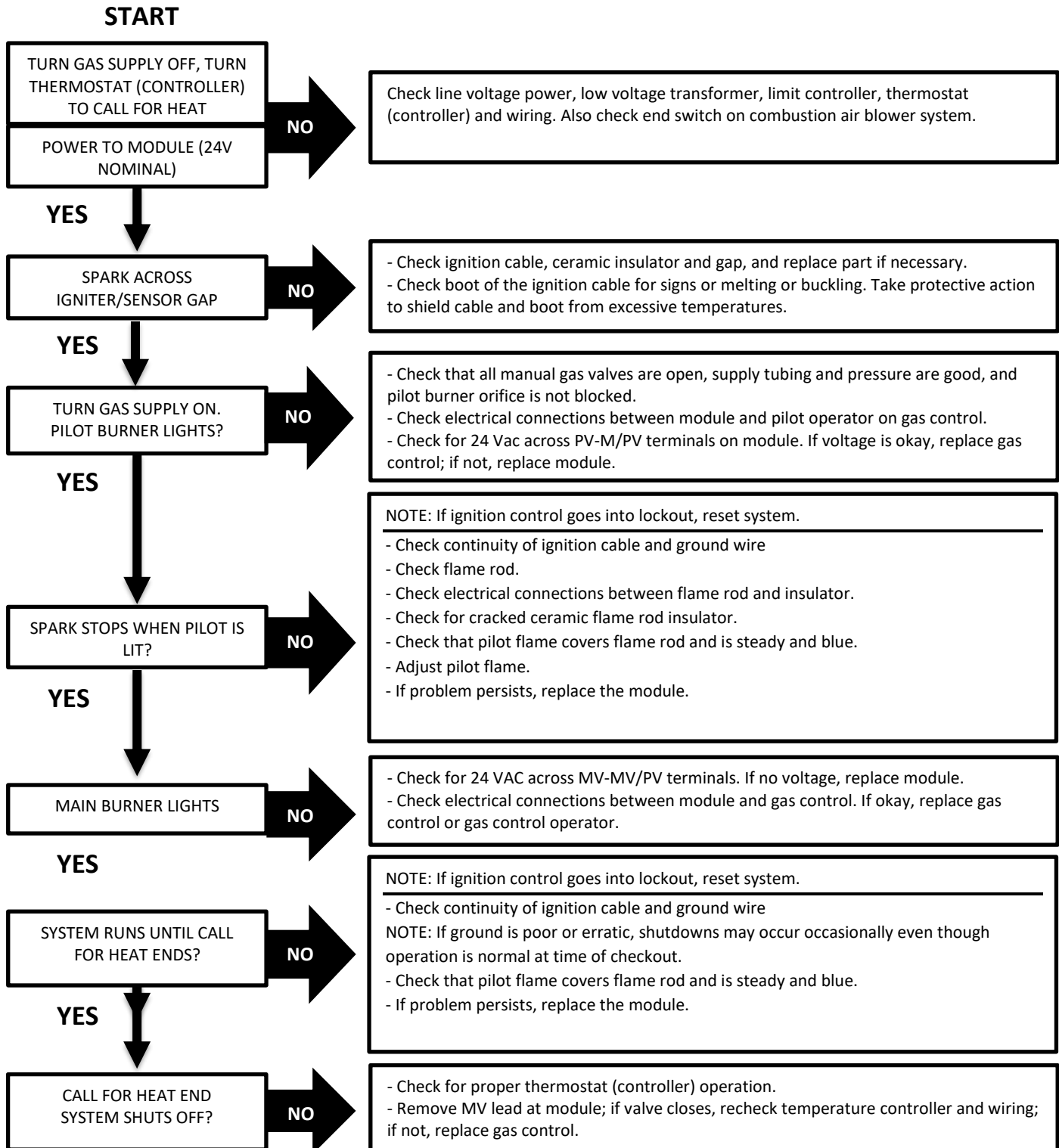

**Table 8: Troubleshooting Chart Electronic Pilot Ignition  
(For Burners Utilizing Fenwal Control)**

Symptoms	Possible Causes
1. PILOT DOES NOT LIGHT.	a. Air in gas line. b. High or low gas pressure. c. Blocked pilot orifice. d. Broken or damaged ignition cable.
2. MOTOR DOES NOT RUN.	a. Thermostat or limit defective or improperly set. b. Relay or transformer defective. c. Motor burned out. d. Improper wiring.
3. MOTOR RUNNING BUT NO FLAME.	a. Very low or no gas pressure to pilot. b. High gas pressure to pilot. c. Defective regulator.

**PRELIMINARY CHECKS, DIAGNOSIS AND SERVICE HINTS  
(ELECTRONIC PILOT IGNITION)**

Although the following tests can be made using standard volt meter, it is quicker and more convenient to use a Fenwal Model 05-125539-001 Test Adapters.

1. Input Polarity

If a spark is present and the gas valve opens for the flame establishing period but the control locks without sensing flame, check the input voltage at terminals 1 and 6 for the proper polarity. Terminal TH or 24V should be "hot"; 24VAC (05-16) with respect to ground. Terminal GND is neutral, or zero voltage, with respect to ground.

2. Improper Grounding

If a flame is present during the Trial for Ignition period but the system shuts down, ensure that the burner is properly grounded. If the burner is not grounded, the flame monitoring signal will not function and the system will go into lockout. Check for loose or corroded terminals and replace if necessary. Ensure good electric connection by scraping paint or any other foreign matter off the area where ground connection is made.

It is equally important to be certain that the electrode bracket assembly is properly grounded. The bracket should be common with the ground lead on the input connector (ground terminal 6). If the bracket is not properly grounded, damage to the ignitor can result.

3. Inoperative High Voltage

If there is no spark or sparking is intermittent, check the following after disconnecting voltage to the system.

- a. Check spark gap. Gap should be 1/8 (3.2mm) +/- 1/32"(.8mm) from H.V. to ground.

**CAUTION: NEVER REPLACE THE COMPONENT BOARD WITHOUT FIRST CHECKING TO ENSURE THAT THE ELECTRODE HAS THE PROPER GAP. IF THE GAP IS TOO WIDE, DAMAGE TO THE IGNITOR CAN RESULT.**

- b. Check electrode leads and determine there is no corrosion at the terminals. If there is corrosion, clean it off. **DO NOT USE LIQUIDS TO CLEAN TERMINALS.** Use steel wool or emery cloth to clean.
- c. Check ceramic insulators for cracks, foreign matter, and carbon. If there are cracks, replace electrodes. If there is carbon or foreign matter, clean it off. **DO NOT USE LIQUIDS TO CLEAN.** Use steel wool or emery cloth to clean.
- d. Check high voltage lead wire for cracks or breaks. If there are cracks, breaks or chafing, replace high voltage wire.
- e. Check to ensure that the high voltage terminal is clear of dust, moisture or any foreign matter that could create high voltage leakage to ground.

4. Valve Malfunction

With power applied to the ignitor, sparking should occur and the solenoid valve should open simultaneously. If sparking occurs but the valve does not open, place a volt meter between Terminal PV1 and ground (or across valve). If valve does not function with voltage, it should be replaced. If the voltage is not present at Terminals PV1 and ground (or across valve), the control should be replaced.

5. Electrode Placement

- a. Electrode should be placed so optimum flame current is achieved for proper application.
- b. Flame should not impinge on any portion of ceramic insulator.

6. Flame Current

The flame detector circuit uses the ionized gas flame to conduct the flame signal. This signal is a small DC current which can be measured directly with a 0 to 50 microamp meter.

The minimum flame current necessary to keep the Honeywell or Fenwal control from going into lockout is 0.8 microamps, the lowest recommended flame current is 1.5 microamps for Honeywell or Fenwal ignition controls.

To measure flame current, first shut off the power to the system and then connect a DC micro amp meter to the FC+ and FC- terminals. Energize the ignitor. If the meter reads below zero, shut the system off and reverse the meter leads.

Once the flame is established, assure that the flame current is above the minimum specified. If not, assure that the system has the proper input voltage, and then adjust the pilot line gas pressure until flame current is increased.

Once the flame is has been established and the system is in its heat cycle, occasional sparking may occur. This is common in some installations and is not significant. Sparking will not damage the ignitor.

**Flame Current Direction Ignition (Wayne Control Only)**

The minimum flame current necessary to keep the Wayne ignition control from going into lockout is 0.08 microamps, the lowest recommended flame current is 0.2 microamps for the Wayne ignition control.

**Table 9: Service Hints**

What's Wrong	Why	What To Do
1. Lockout occurs 3-10 seconds after ignition.	<ol style="list-style-type: none"> <li>Reverse polarity.</li> <li>System improperly grounded.</li> <li>Gas pressure too high, causing flame to lift off burner.</li> </ol>	See Input Polarity (See 1) See Improperly Grounding (See 2) Check to ensure input pressure as specified on manufacturer's data plate. See Flame Current (See 6)
<ol style="list-style-type: none"> <li>Flame not established. Arcing to ground.</li> <li>No spark.</li> <li>Arcing other than across gap.</li> </ol>	<ol style="list-style-type: none"> <li>Sensor probe incorrectly positioned in flame pattern. Spark gap too small. Spark too large. Corroded connector.</li> <li>Cracked or dirty insulator.</li> </ol>	See Inoperative High Voltage (See 3a)
5. Weak spark.	<ol style="list-style-type: none"> <li>Broken high voltage lead. High voltage lead too close to metal surface. Valve malfunction. Electrode improperly placed.</li> </ol>	See Valve Malfunction (See 4) See Electrode Placement (See 5) See Flame Current (See 6)
No flame. Low flame current and/or nuisance lockouts.	<ol style="list-style-type: none"> <li>Flame current falls below 0.8 <math>\mu</math>a or 0.08 <math>\mu</math>a (Wayne Control).</li> <li>Low gas pressure.</li> </ol>	Check to ensure that manifold pressure meets manufacturer's specifications

**COMPONENT TROUBLESHOOTING AND DIAGNOSIS**

24 VOLT TRANSFORMER MALFUNCTION

The 24 volt transformer has a 115 volt primary side with a 24 volt secondary circuit. To check the transformer, simply apply 115 volts to the black and white leads. If the transformer is working correctly, 24 volts will be present across the two yellow leads. If the multimeter does not register 24 volts then the transformer needs to be replaced. The transformer will not function unless 115 volts are present across L1 and neutral.

COMBUSTION FAN ENDSWITCH

The 115 volt motor is equipped with a centrifugal switch. The purpose of the switch is to ensure that the combustion fan motor has reached the proper operating RPM which is generally about 3400 rpm. If the end switch fails to close then the 24 volt circuit to the gas primary is interrupted and the gas valve will not open. If the blower motor has 115 volts applied but is not rotating then the motor assembly must be replaced. Lastly if the motor is not rotating, the centrifugal switch will not make and 24 volts will not be present at the gas primary control.

IGNITER ROD

The igniter rod is responsible for conveying the spark to a grounding rod in an appropriate location to ignite the gas and air mix. The igniter rod gap should be 1/8", larger gaps will create ignition problems. If the igniter rod is cracked, sparking sound will be heard inside the burner air tube but ignition will not occur and lockout will occur.

## MORE SERVICE HINTS

THERMOSTAT CALLS FOR HEAT AND THE FOLLOWING CONDITIONS OCCUR:

1. **PROBLEM:** The combustion fan motor is not operating.  
Possible Reasons:
  - a. Power is not on.
  - b. Circuit breaker tripped.
  - c. Thermostat in the off position.
  - d. Thermostat connections to T-T terminals on junction box have shorted to the junction box.
  - e. Bad thermostat.
  - f. Blower wheel jammed
  - g. Debris stuck in blower wheel blades.
  - h. 24 volt transformer is not functioning properly.
  - i. Thermostat leads not connected to the T-T terminals.
  - j. Motor shorted out due to over voltage.
  - k. Motor start relay not functioning properly.
  
2. **PROBLEM:** Combustion fan motor runs but ignition sequence does not occur.  
Possible Reasons:
  - a. Blower motor end switch not closed which completes the 24 volt circuit to the gas primary.
  - b. The blower motor is not reaching full rpm due to debris on wheel.
  - c. Low voltage to the blower motor.
  - d. Loose connections on the 24 volt circuit after the end switch or between fan relay and the 24 volt side of the gas primary.
  - e. The gas primary control is defective and must be replaced.
  
3. **PROBLEM:** Combustion fan motor runs and ignition sequence initiated but goes into lockout.  
Possible Reasons:
  - a. Spark electrode rod is cracked shorting spark to ground.
  - b. Loose connection on spark electrode rod.
  - c. Gas primary control not allowing 24 volts to gas valve.
  - d. Gas valve shorted out or defective.
  - e. No ground between burner and appliance.
  - f. Spark electrode location shifted.
  - g. Gas primary control not generating spark.
  - h. Ignition wire insulation melted and is grounding out on burner.
  - i. Gas supply is not turned on.
  - j. Gas manifold pressure is too high.
  - k. Gas manifold pressure is too low.
  - l. High negative draft conditions.
  - m. Gas supply line is undersized.
  - n. Multiple appliances operating on undersized line.
  - o. Insufficient combustion air flow.
  - p. Incorrect air shutter adjustment allowing too much combustion air to enter burner.

**P250 DIRECT  
IGNITION IGNITOR  
POSITION**

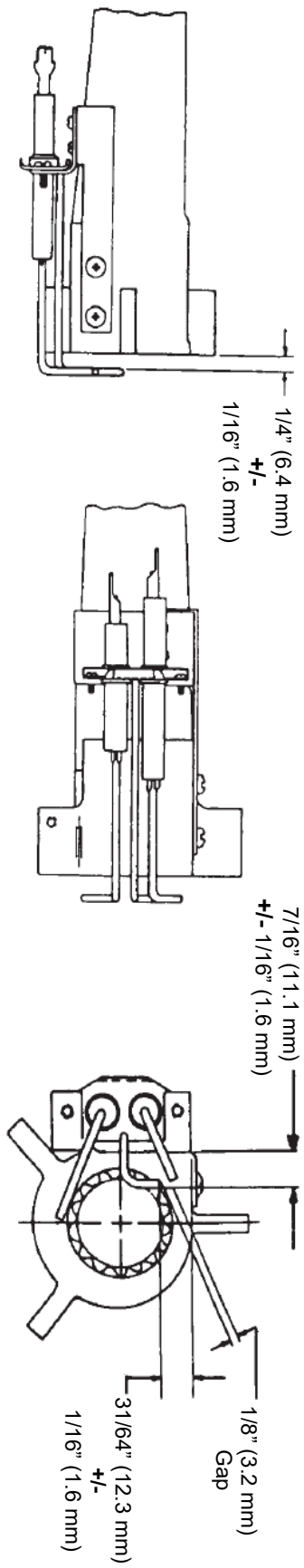

**P265 DIRECT  
IGNITION IGNITOR  
POSITION**

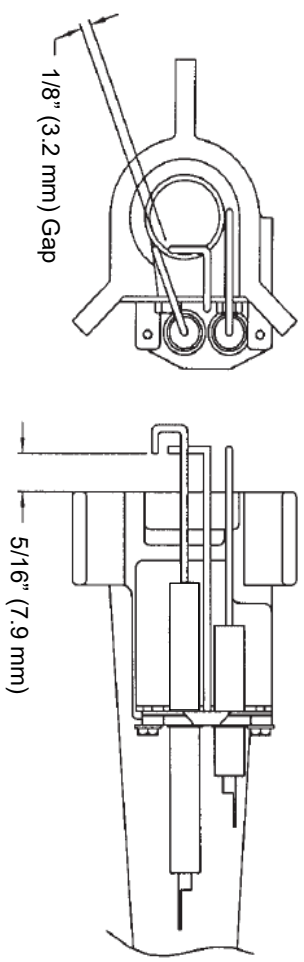

**FIGURE 24**

P250/P265 NON -E SERIES WIRING DIAGRAMS

**CAUTION**

Label all wires prior to disconnection when servicing controls. Wiring errors can cause improper and dangerous operation. Verify proper operation after servicing.



WIRING DIAGRAM  
DIRECT IGNITION— WAYNE CONTROL

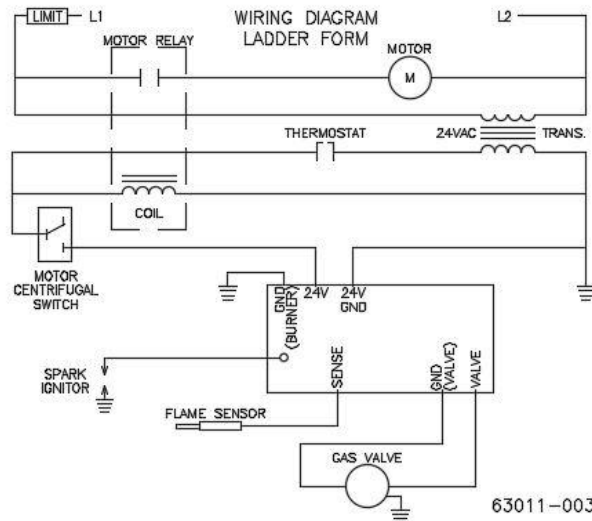
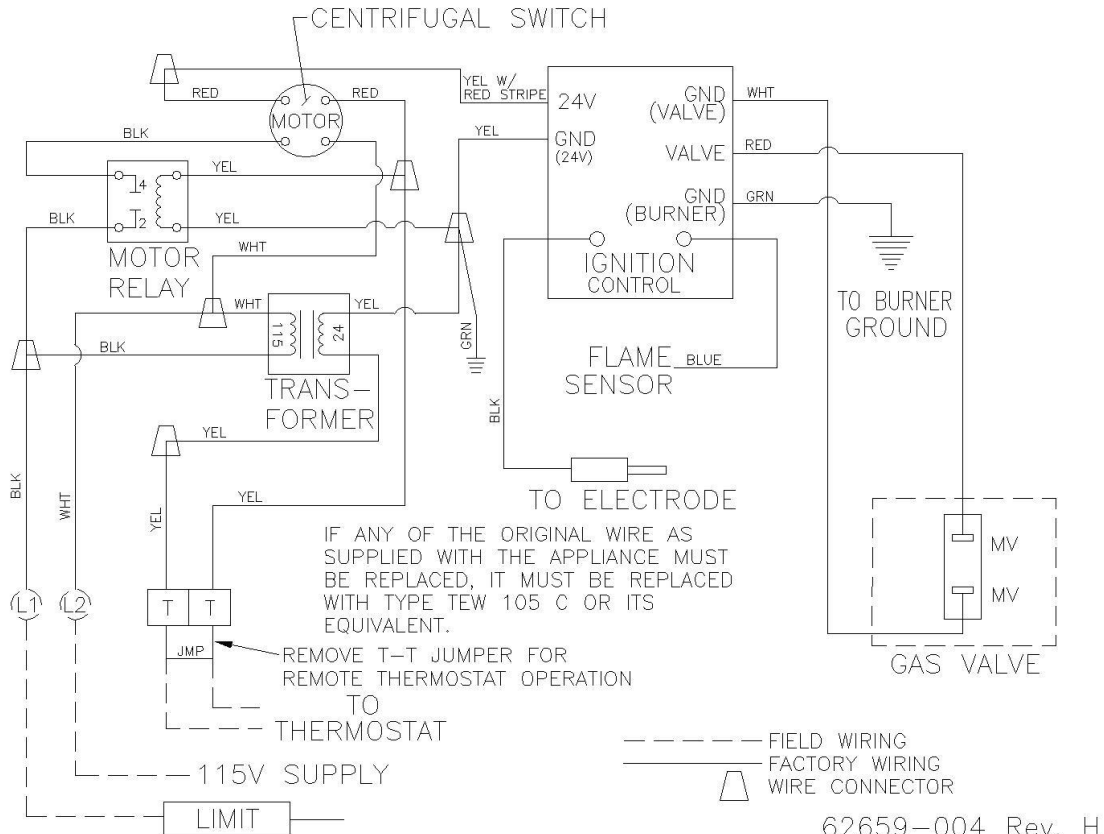
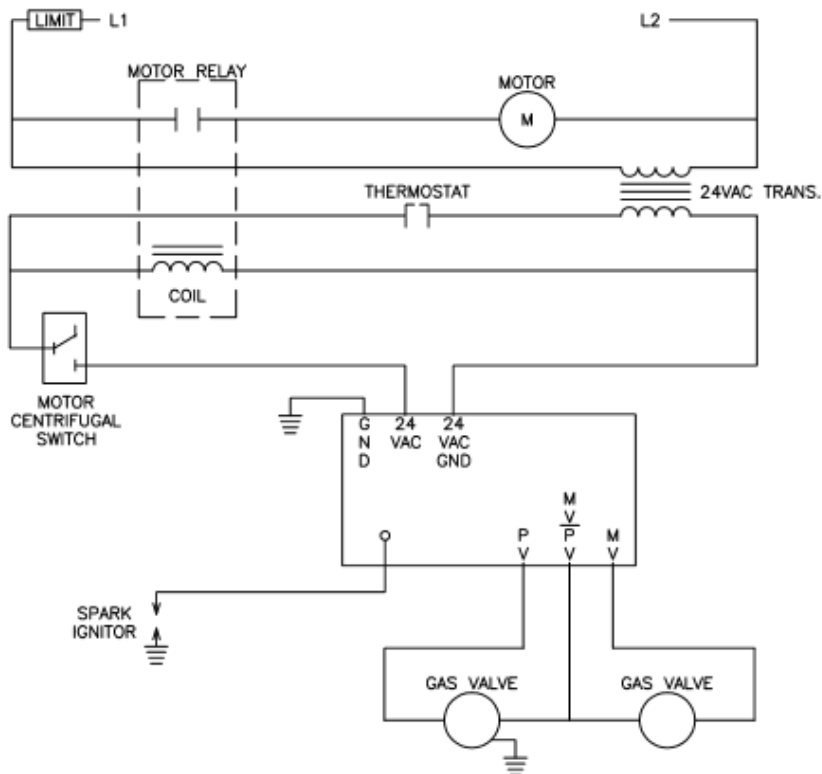
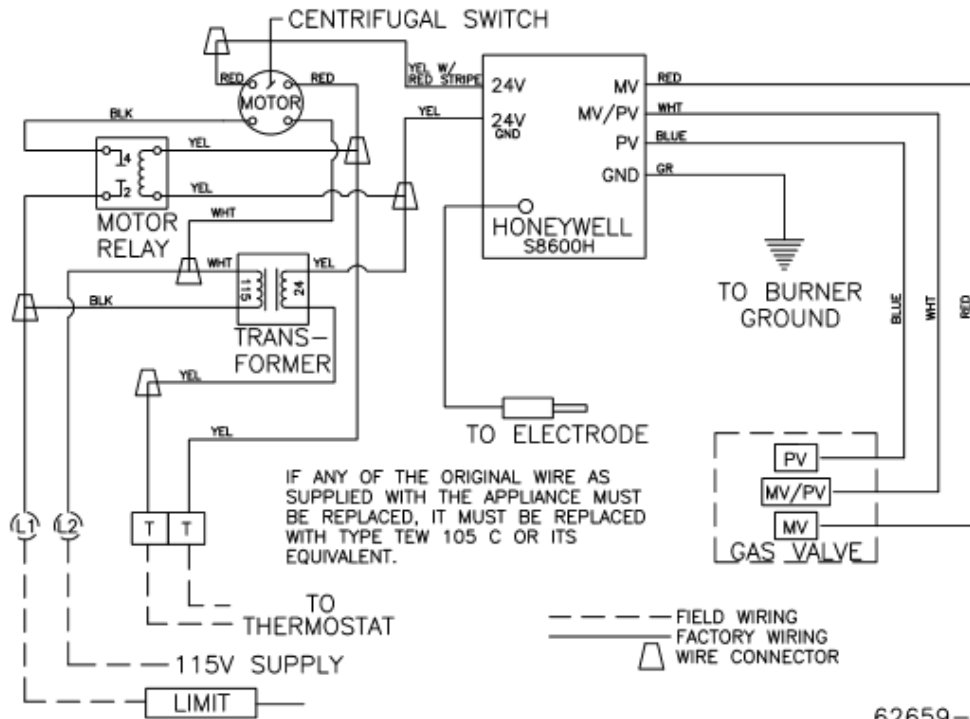

FIGURE 25: WIRING DIAGRAM FOR GAS BURNER WITH DIRECT IGNITION-WAYNE





# WIRING DIAGRAM ELECTRONIC PILOT-HONEYWELL CONTROL



**FIGURE 28: WIRING DIAGRAM FOR GAS BURNER WITH ELECTRONIC PILOT-HONEYWELL**

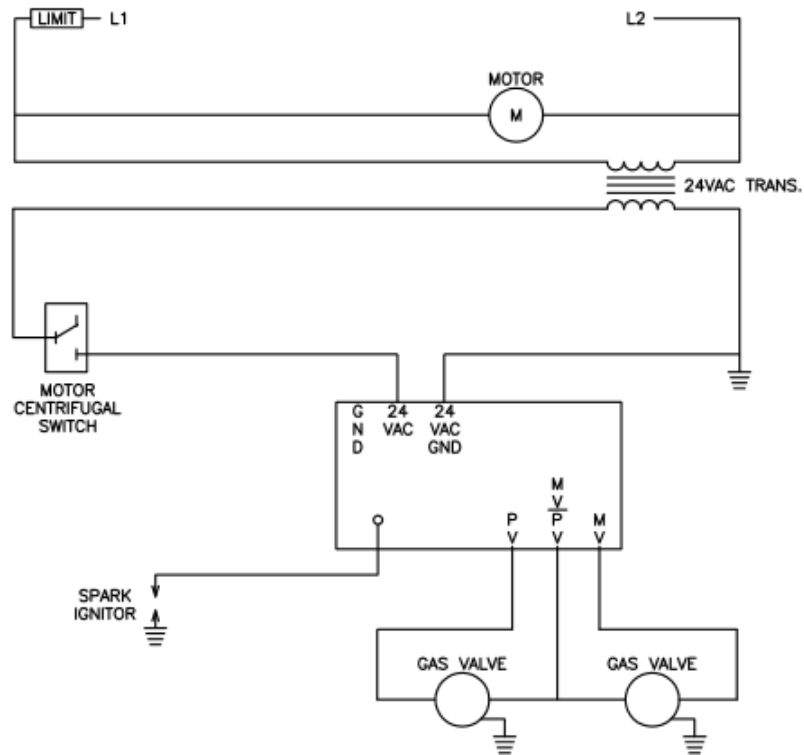
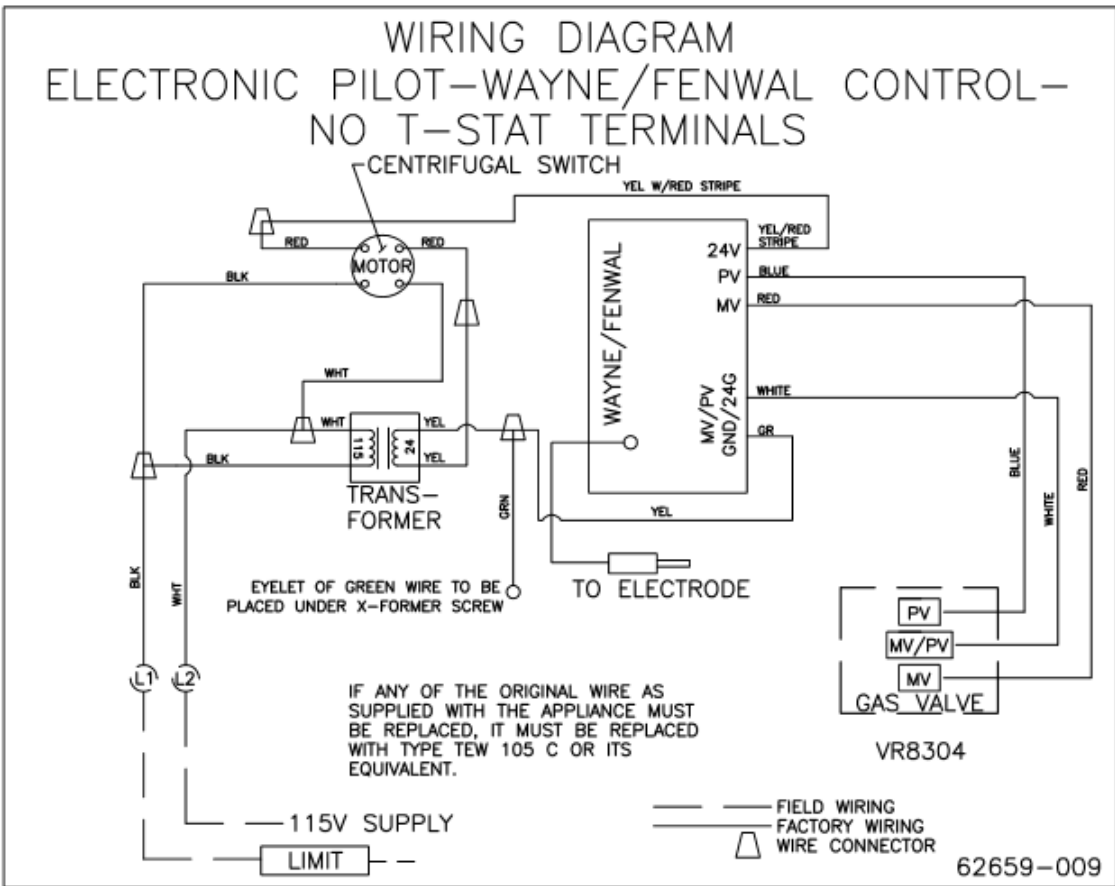

LADDER WIRING DIAGRAM

FIGURE 29: WIRING DIAGRAM FOR GAS BURNER WITH ELECTRONIC PILOT-NO T-STAT

# WIRING DIAGRAM ELECTRONIC PILOT-WAYNE/FENWAL CONTROL

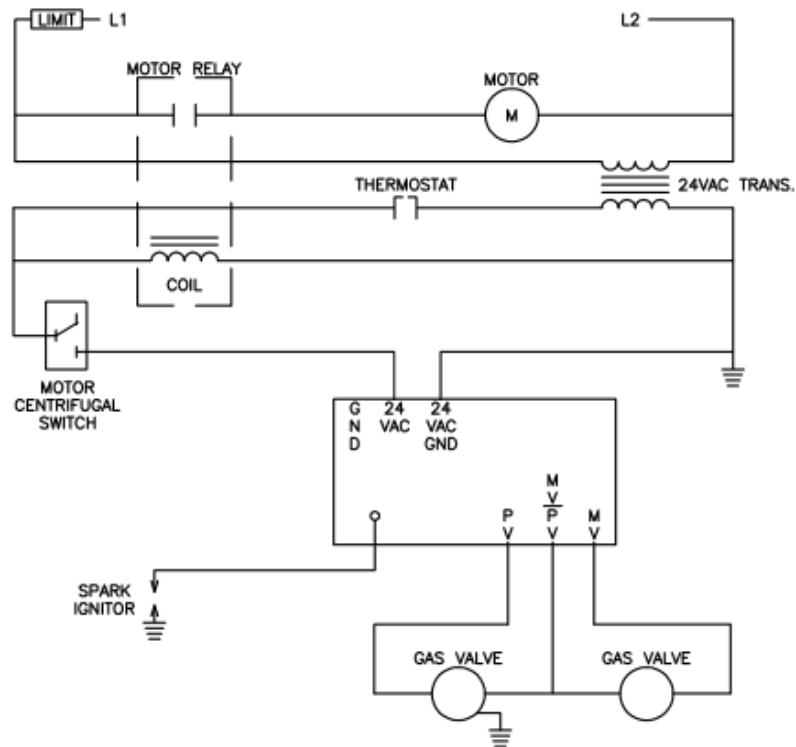
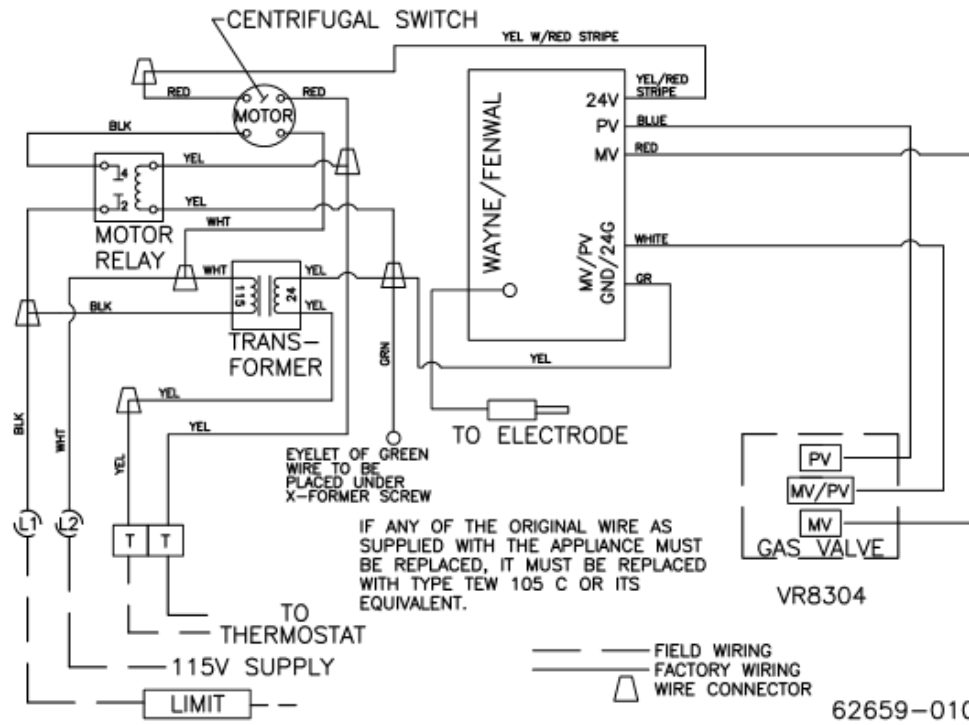

LADDER WIRING DIAGRAM

FIGURE 30: WIRING DIAGRAM FOR GAS BURNER WITH ELECTRONIC PILOT-FENWAL

P250/P265F -E SERIES WIRING DIAGRAM

**CAUTION**



Label all wires prior to disconnection when servicing controls. Wiring errors can cause improper and dangerous operation. Verify proper operation after servicing.

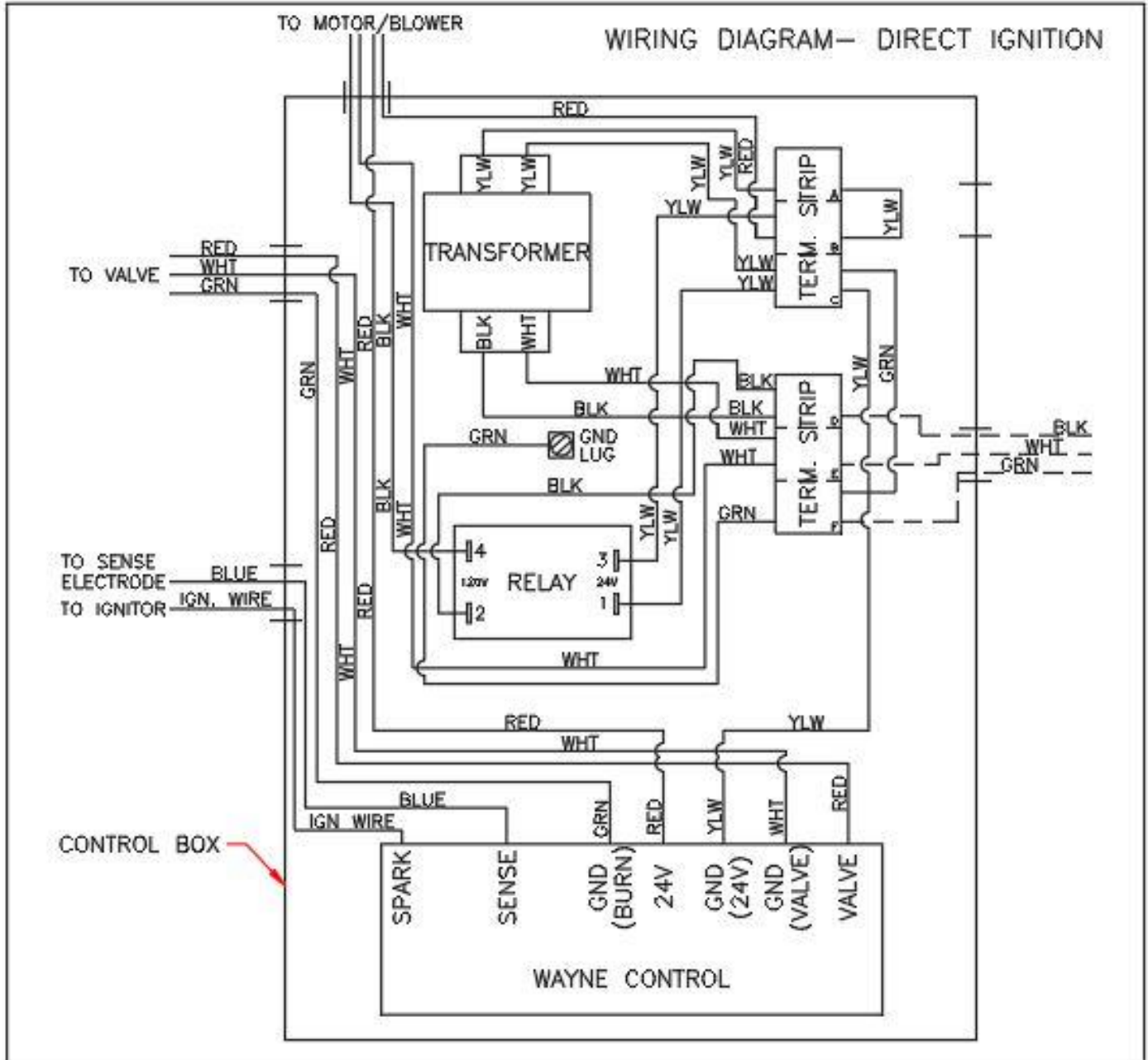
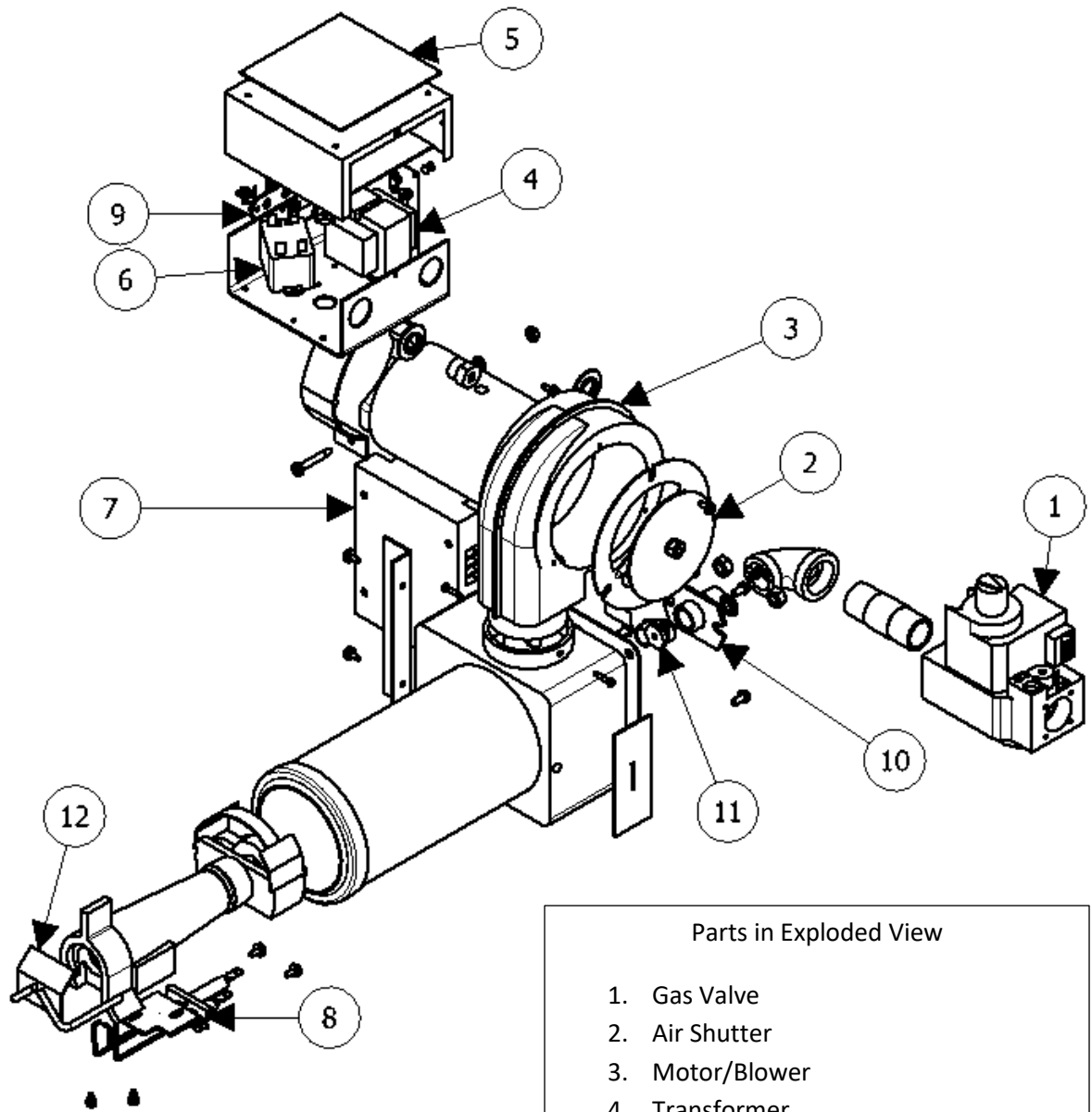

FIGURE 31: WIRING DIAGRAM FOR -E SERIES GAS BURNER WITH DIRECT IGNITION

## SECTION VI: PARTS LIST AND EXPLODED VIEWS

### P265F EXPLODED VIEWS



#### Parts in Exploded View

1. Gas Valve
2. Air Shutter
3. Motor/Blower
4. Transformer
5. Model/Specification Label
6. Motor Relay
7. Ignition Control
8. Electrode/Sensor/Ground Rod Asm
9. T-T Terminal
10. Orifice Holder
11. Orifice
12. Flame spreader

FIGURE 32: Right Side Exploded View of P265F

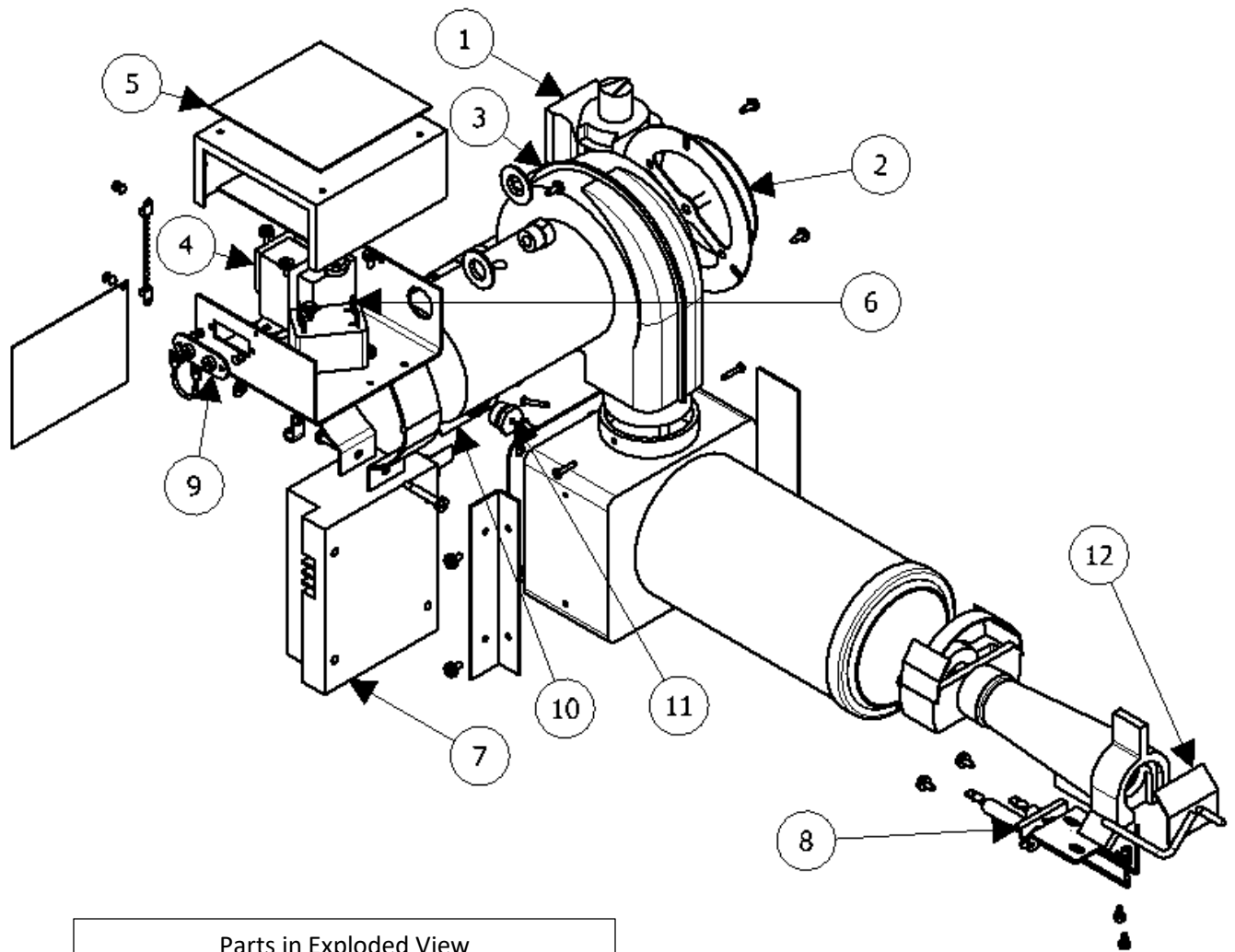

Parts in Exploded View

1. Gas Valve
2. Air Shutter
3. Motor/Blower
4. Transformer
5. Model/Specification Label
6. Motor Relay
7. Ignition Control
8. Electrode/Sensor/Ground Rod Asm
9. T-T Terminal
10. Orifice Holder
11. Orifice
12. Flame spreader

FIGURE 33: Left Side Exploded View of P265F

P265F PARTS LIST		Qty Req'd	P265F EPN	P265F EPLP	P265F DIN	P265F DILP	P265F DIN BOILER	
Part No.	Item Description							
60172-SER	Motor/Blower Asm (w/o Control Box)	1	●	●	●	●	●	
61803	Control Box Asm (Incl. Trans. & Relay)	1	●	●	●	●	●	
61875	Motor/Blower & Control Box Pkg.	1	●	●	●	●	●	
62406-SER	Motor Relay	1	●	●	●	●	●	
60186-SER	Transformer-24V	1	●	●	●	●	●	
60178-002	Terminal Strip	1	●	●	●	●	●	
62510-SER	Air Shutter Asm (Btu/hr)	1	●	●	●	●	●	
63566-SER	*Air Shutter Asm (≤160,000 Btu/hr) (Optional)	1	●	●	●	●	●	
62715-001	Air Tube/Housing Asm	1		5"				
62715-002	Air Tube/Housing Asm	1	5"		5"	5"		
62715-004	Air Tube/Housing Asm	1	8"	8"	8"	8"		
62715-006	Air Tube/Housing Asm	1	11"	11"	11"	11"		
62715-007	Air Tube/Housing Asm	1					●	
21724-011	Adjustable Flange & Gasket Pkg.	1	●	●	●	●	●	
100428-002	Flange Gasket	1	●	●	●	●	●	
21760-011	Base (Pedestal) Pkg.	1	●	●	●	●	●	
62246-SERN	Gas Valve-"EP" Models (Nat.)	1	●					
62256-SERLP	Gas Valve-"EP" Models (LP)	1		●				
62374-SERN	Gas Valve-"DI" Models (Nat.)	1			●		●	
62374-SERLP	Gas Valve-"DI" Models (LP)	1				●		
62898-001	Orifice Holder Asm	1	●	●	●	●	●	
Varies	Main Burner Orifice-Nat.	1	Refer to Orifice Chart					
Varies	Main Burner Orifice-LP	1	Refer to Orifice Chart					
60533	Main Burner Orifice Blank (field drilled)	1	●	●	●	●	●	
60944	Venturi Asm	1		●				
61403	Venturi Asm	1	●					
61403-002	Venturi Asm	1				8" and 11"		
61637-004	Venturi Asm	1			5"		●	
63062-SER	Pilot Burner-.024" Pilot Orifice	1	●					
64008-SER	Pilot Burner-.018" Pilot Orifice	1		●				
62261-SER2	Electrode/Sensor/Ground Rod Asm	1			●	●	●	
62947-003	Ignitor Lead Wire (S8600 and S87K Only)	1	●	●	●	●	●	
63436-003	Ignitor Lead Wire (Wayne Control)	1			●	●	●	
62243-003	Ignition Control-Hon. S8600H3002	1	●	●				
64414-SER	Ignition Control-Wayne	1			●	●	●	
62245-001	Wire Harness (5 wire)	1	●	●				
63375-001	Wire Harness (3 wire)				●	●	●	
63103-001	Window Plug (Sight Glass)	1	●	●	●	●	●	
	*NOTE: Only for firing rate of 160,000 Btu/hr or less when finer adjustment at low rate is required.							

### P250AF EXPLODED VIEWS

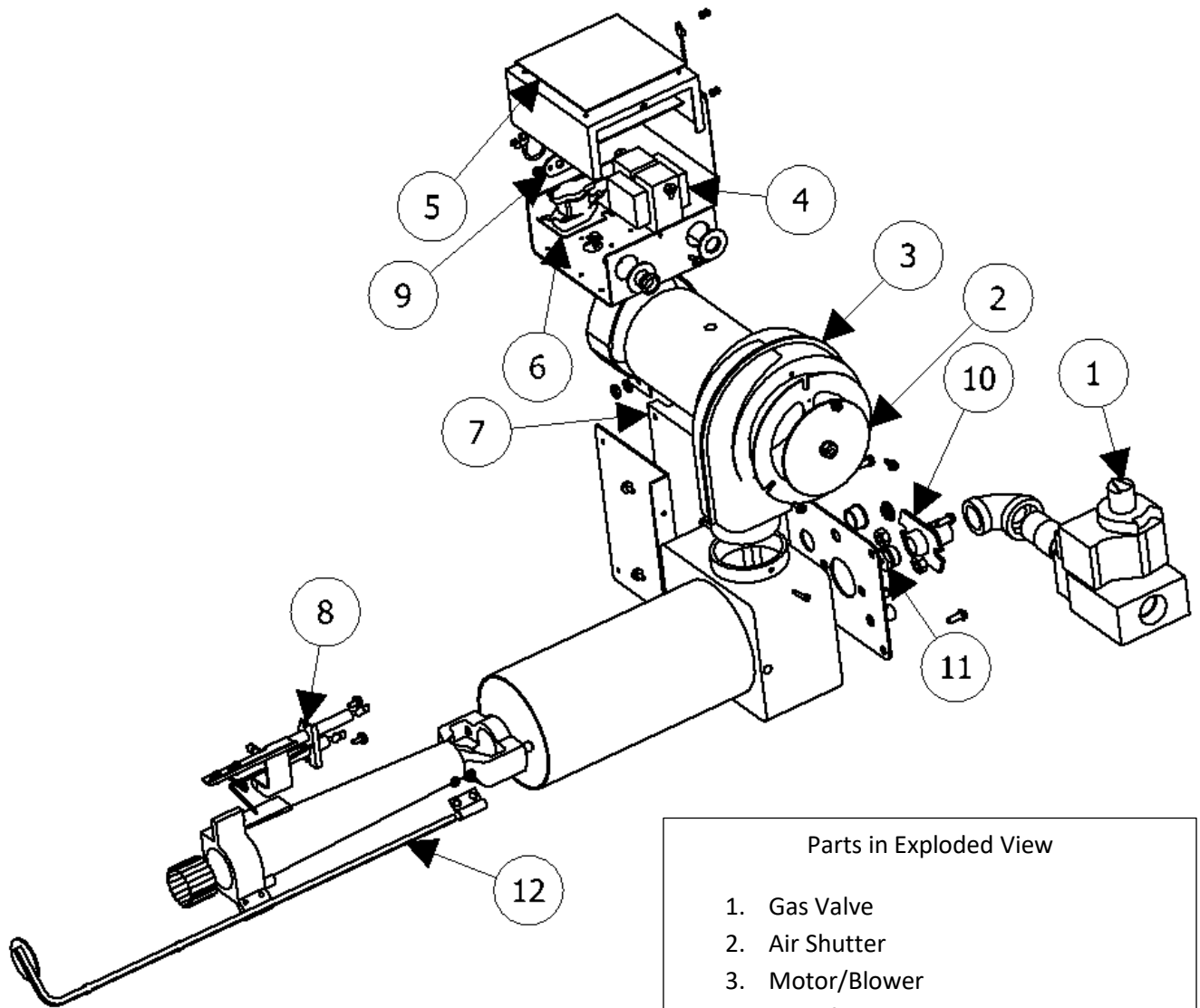

- Parts in Exploded View
1. Gas Valve
  2. Air Shutter
  3. Motor/Blower
  4. Transformer
  5. Model/Specification Label
  6. Motor Relay
  7. Ignition Control
  8. Electrode/Sensor/Ground Rod ASM
  9. T-T Terminal
  10. Orifice Holder
  11. Orifice
  12. Flame spreader

**FIGURE 34: Right Side Exploded View of P250AF**

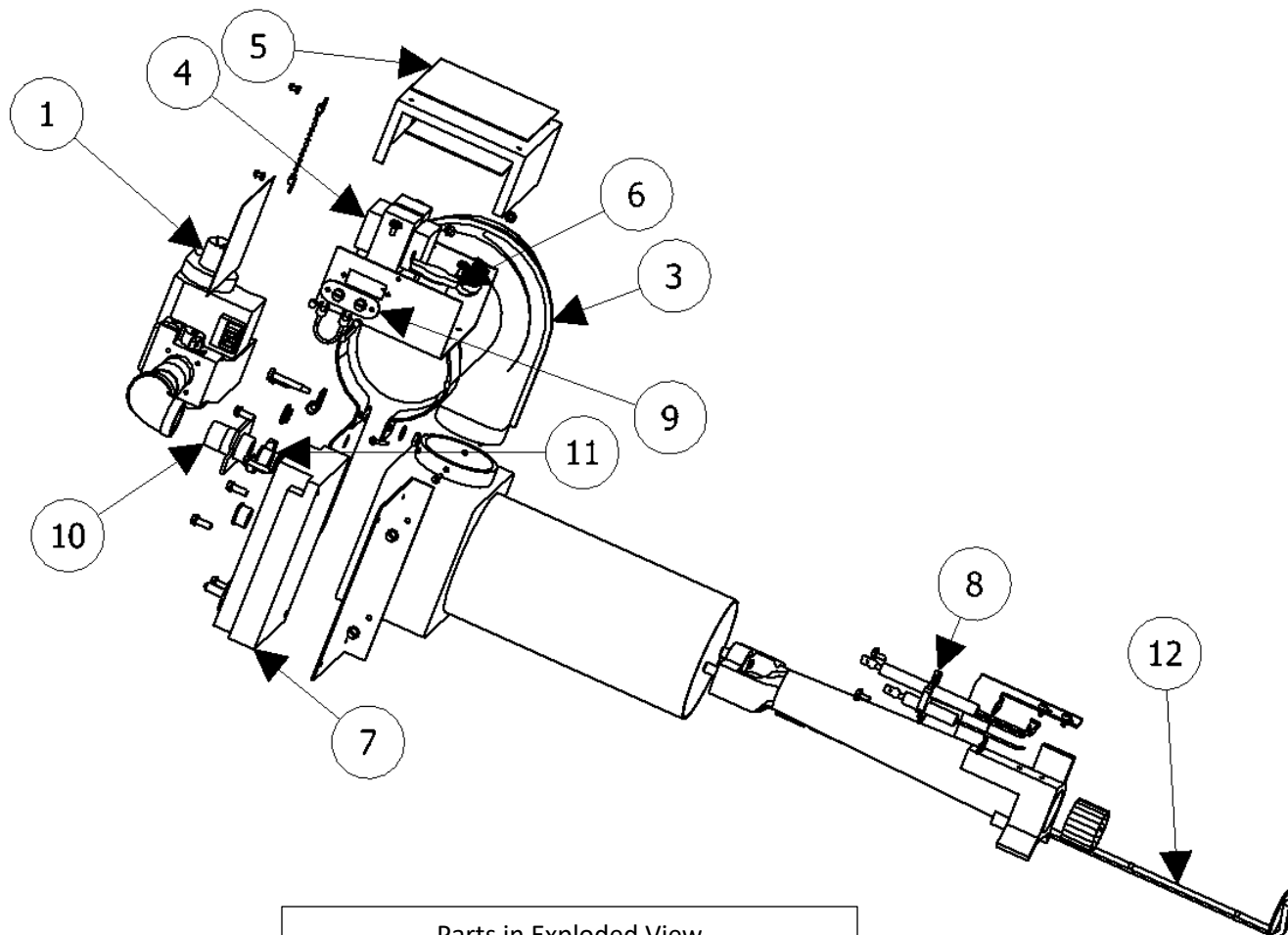

Parts in Exploded View

1. Gas Valve
2. Air Shutter
3. Motor/Blower
4. Transformer
5. Model/Specification Label
6. Motor Relay
7. Ignition Control
8. Electrode/Sensor/Ground Rod ASM
9. T-T Terminal
10. Orifice Holder
11. Orifice
12. Flame spreader

**FIGURE 35: Left Side Exploded View of P250AF**

P250AF PARTS LIST		Qty Req'd	P250AF EPN	P250AF EPLP	P250AF DIIN	P250AF DILP
Part No.	Item Description					
60172-SER	Motor/Blower Asm (w/o Control Box)	1	●	●	●	●
61803	Control Box Asm (Incl. Trans. & Relay)	1	●	●	●	●
61875	Motor/Blower & Control Box Pkg.	1	●	●	●	●
62406-SER	Motor Relay	1	●	●	●	●
60186-SER	Transformer-24V	1	●	●	●	●
60178-002	Terminal Strip	1	●	●	●	●
62510-SER	Air Shutter Asm	1	●	●	●	●
63566-SER	*Air Shutter Asm (≤160,000 Btu/hour) (Optional)	1	●	●	●	●
62715-003	Air Tube/Housing Asm	1	●	●	●	●
21724-011	Adjustable Flange & Gasket Pkg.	1	●	●	●	●
100428-002	Flange Gasket	1	●	●	●	●
21760-011	Base (Pedestal) Pkg.	1	●	●	●	●
62246-SERN	Gas Valve-"EP" Models (Nat.)	1	●	●		
62256-SERLP	Gas Valve-"EP" Models (LP)	1	●	●		
62374-SERN	Gas Valve-"DI" Models (Nat.)	1			●	●
62374-SERLP	Gas Valve-"DI" Models (LP)	1			●	●
62898-001	Orifice Holder Asm	1	●	●	●	●
Varies	Main Burner Orifice-Nat.	1	<b>Refer to Orifice Chart</b>			
Varies	Main Burner Orifice-LP	1	<b>Refer to Orifice Chart</b>			
60533	Main Burner Orifice Blank (field drilled)	1	●	●	●	●
61817	Venturi Asm	1	●	●	●	●
60748	Flame Retention Ring Asm	1	●	●	●	●
61818	Flame spreader Asm	1	●	●	●	●
63062-001	Pilot Burner Asm-Nat.	1	●			
64008-SER	Pilot Burner Asm-LP	1		●		
62261-SER	Electrode/Sensor/Ground Rod Asm	1			●	●
62947-003	Ignitor Lead Wire (S87K and Fen Only)	1			●	●
63436-003	Ignitor Lead Wire (Wayne Control)	1			●	●
80275	Ignition Control-Fen.	1	●	●		
101243-001	Ignition Control-Hon. S87K1008	1			●	●
64414-SER	Ignition Control-Wayne	1			●	●
62245-007	Wire Harness (6 wire)	1	●	●		
63375-001	Wire Harness (3 wire)	1			●	●
63103-001	Window Plug (Sight Glass)	1	●	●	●	●
	*NOTE: Only for firing rate of 160,000 Btu/hr or less when finer adjustment at low rate is required.					

# P250AF -E EXPLODED VIEW

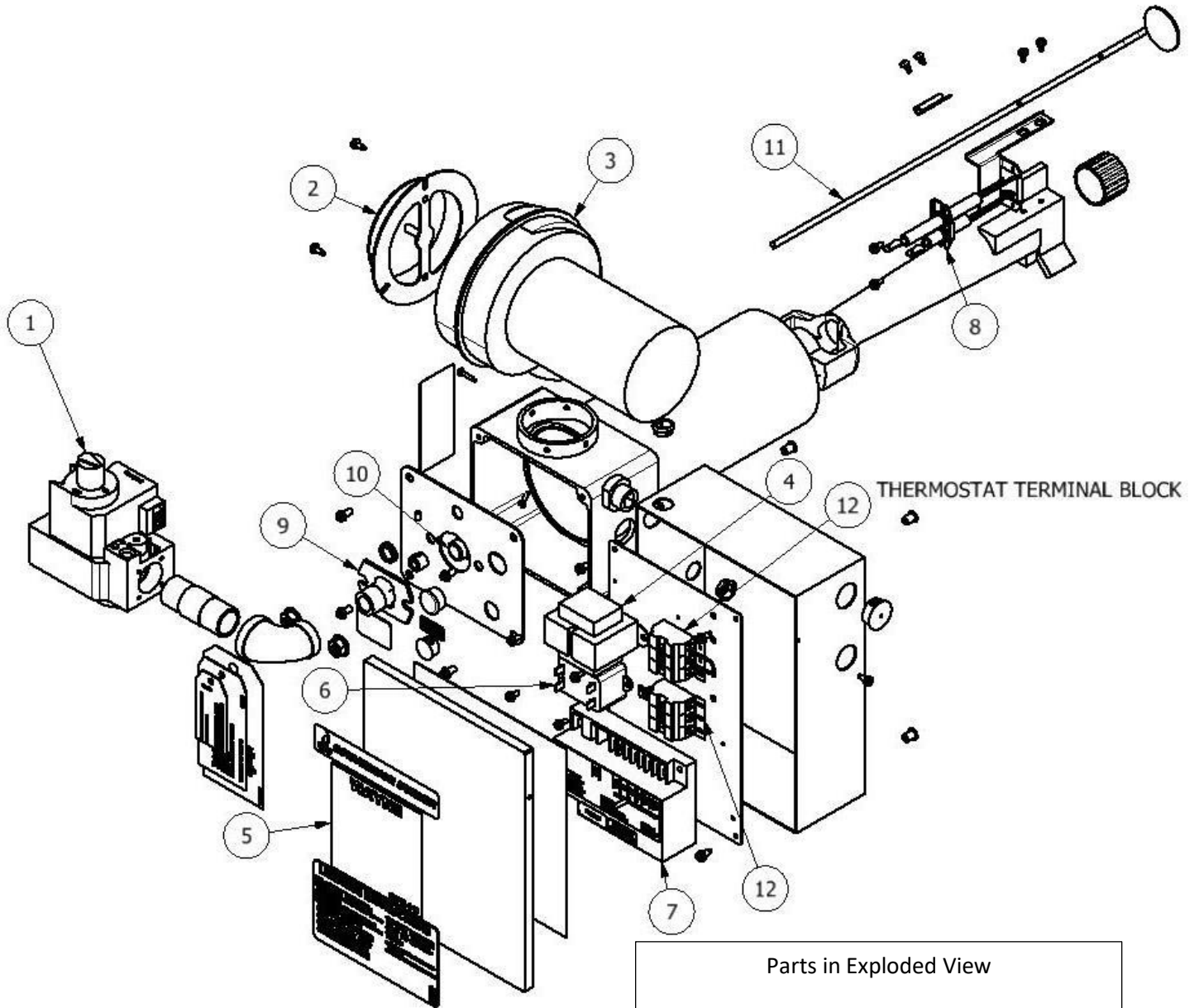

- Parts in Exploded View
- 1. Gas Valve
  - 2. Air Shutter
  - 3. Motor/Blower
  - 4. Transformer
  - 5. Model/Specification Label
  - 6. Motor Relay
  - 7. Ignition Control
  - 8. Electrode/Sensor/Ground Rod ASM
  - 9. Orifice Holder
  - 10. Orifice
  - 11. Flame spreader
  - 12. Terminal Block

FIGURE 36: Exploded View of P250AF-E Series

P250AF -E SERIES PARTS LIST		Qty Req'd	P250AF DIN-E	P250AF DILP
Part No.	Item Description			
64388-SER	Motor/Blower	1	●	●
63592-003	Terminal, Block	2	●	●
62406-SER	Motor Relay	1	●	●
60186-SER	Transformer-24V	1	●	●
60178-002	Terminal Strip	1	●	●
62510-SER	Air Shutter Asm	1	●	●
63566-SER	*Air Shutter Asm ( $\leq 160,000$ Btu/hour) (Optional)	1	●	●
62715-303	Air Tube/Housing Asm	1	●	●
21724-011	Adjustable Flange & Gasket Pkg.	1	●	●
100428-002	Flange Gasket	1	●	●
21760-011	Base (Pedestal) Pkg.	1	●	●
62374-SERN	Gas Valve-"DI" Models (Nat.)	1	●	●
62374-SERLP	Gas Valve-"DI" Models (LP)	1	●	●
62898-001	Orifice Holder Asm	1	●	●
Varies	Main Burner Orifice-Nat.	1	<b>Refer to Orifice Chart</b>	
Varies	Main Burner Orifice-LP	1	<b>Refer to Orifice Chart</b>	
60533	Main Burner Orifice Blank (field drilled)	1	●	●
61817	Venturi Asm (Order with P/N 60748)	1	●	●
60748	Flame Retention Ring Asm	1	●	●
61818	Flame spreader Asm	1	●	●
62261-SER	Electrode/Sensor/Ground Rod Asm	1	●	●
64411-002	Ignitor Lead Wire (Wayne Control)	1	●	●
64395-SER	Ignition Control-Wayne	1	●	●
64410-001	Wire Harness (6 wire)	1	●	●
63103-001	Window Plug (Sight Glass)	1	●	●
	*NOTE: Only for firing rate of 160,000 Btu/hr or less when finer adjustment at low rate is required.			

## P265F -E EXPLODED VIEW

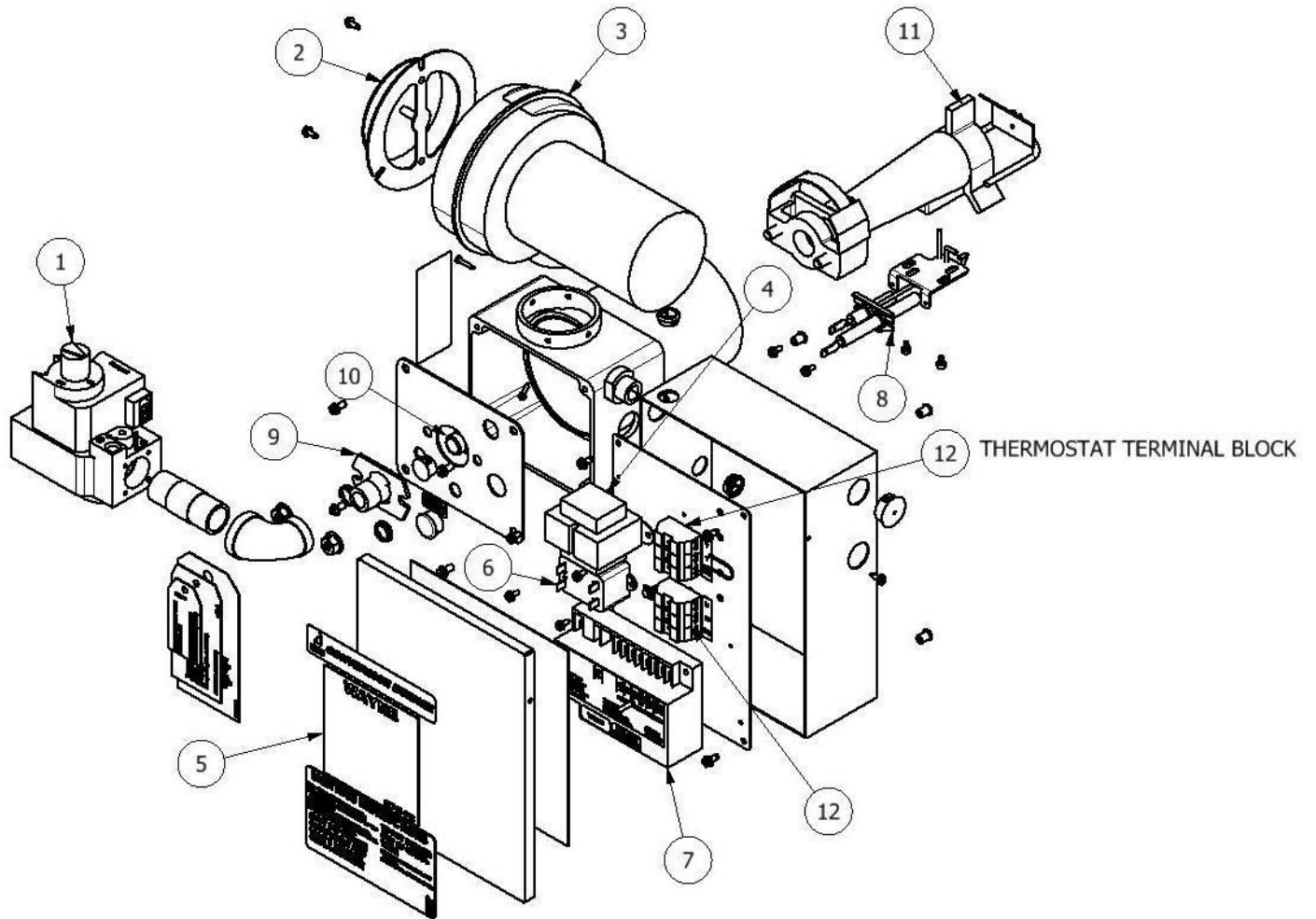

### Parts in Exploded View

1. Gas Valve
2. Air Shutter
3. Motor/Blower
4. Transformer
5. Model/Specification Label
6. Motor Relay
7. Ignition Control
8. Electrode/Sensor/Ground Rod ASM
9. Orifice Holder
10. Orifice
11. Venturi/Flame Spreader ASM
12. Terminal Block

FIGURE 37: Exploded View of P265F -E

P265F -E SERIES PARTS LIST		Qty Req'd	P265F BB DIN-E	P265F DIN-E	P265F DILP-E
Part No.	Item Description				
64388-SER	Motor/Blower	1	●	●	●
63592-003	Terminal, Block	2	●	●	●
62406-SER	Motor Relay	1	●	●	●
60186-SER	Transformer-24V	1	●	●	●
62510-SER	Air Shutter Asm (Btu/hr)	1	●	●	●
60353-SER	*Air Shutter Asm (≤160,000 Btu/hr)(Optional)	1	●	●	●
62715-302	Air Tube/Housing Asm	1		5"	5"
62715-304	Air Tube/Housing Asm	1		8"	
62715-306	Air Tube/Housing Asm	1		11"	11"
62715-308	Air Tube/Housing Asm	1	●		
21724-011	Adjustable Flange & Gasket Pkg.	1	●	●	●
100428-002	Flange Gasket	1	●	●	●
21760-011	Base (Pedestal) Pkg.	1	●	●	●
62374-SERN	Gas Valve-"DI" Models (Nat.)	1	●	●	
62374-SERLP	Gas Valve-"DI" Models (LP)	1			●
62898-001	Orifice Holder Asm	1	●	●	●
Varies	Main Burner Orifice-Nat.	1	<b>Refer to Orifice Chart</b>		
Varies	Main Burner Orifice-LP	1	<b>Refer to Orifice Chart</b>		
60533	Main Burner Orifice Blank (field drilled)	1	●	●	●
61637-004	Venturi Asm	1		5"	5"
61403-002	Venturi Asm	1		8" and 11"	11"
61637-004	Venturi Asm	1	●		
62261-SER2	Electrode/Sensor/Ground Rod Asm	1	●	●	●
64411-002	Ignitor Lead Wire (Wayne)	1	●	●	●
64395-SER	Ignition Control-Wayne	1	●	●	●
64410-001	Wire Harness (4 wire)	1	●	●	●
63103-001	Window Plug (Sight Glass)	1	●	●	●
	*NOTE: Only for firing rate of 160,000 Btu/hr or less when finer adjustment at low rate is required.				



**WAYNE COMBUSTION SYSTEMS**

## **SECTION VII: WARRANTY**

# **LIMITED WARRANTIES FOR OIL AND GAS BURNERS, MADE BY WAYNE AND USED IN RESIDENTIAL INSTALLATIONS**

**WAYNE COMBUSTION SYSTEMS ("WAYNE")** warrants to those who purchase its **Oil Burner Models** for resale or for incorporation into a product of resale, that its burner is free from defects in material and workmanship under normal use and service for thirty-six (36) months from the date of manufacture. **ALL GAS BURNERS** manufactured by "WAYNE" will be similarly warranted for eighteen (18) months from date of manufacture except where original manufacture offers a greater warranty. (Reference #6 below) THESE LIMITED WARRANTIES DO NOT APPLY UNLESS THE BURNER COVERED BY IT IS PROPERLY INSTALLED BY A **QUALIFIED, COMPETENT TECHNICIAN**, WHO IS LICENSED WHERE STATE AND/OR LOCAL CODES PREVAIL, AND **WHO IS EXPERIENCED IN MAKING SUCH INSTALLATIONS**, in accordance with NFPA #31 of the national fire protection association and in accordance with all local, state and national codes.

Any **IN-WARRANTY** burner component which is defective in material or workmanship will be either repaired or replaced as follows:

1. Fuel pumps, motors, transformers, gas valves, and controls should be returned to an authorized service station or distributor of WAYNE for determination of applicability of this LIMITED WARRANTY as to either repair or replacement, where said service station or distributor is reasonably available in the customer's locality. The manufacturers of burner components regularly publish and distribute listings showing the locations of their network of service stations. Where such local service is NOT available for the burner components described above or other burner parts are involved, these items should be returned, freight prepaid, to WAYNE Service Department, 3623 Independence Drive, Fort Wayne, Indiana 46808.
2. Burners and/or component(s) determined to be covered under this LIMITED WARRANTY by WAYNE shall be repaired or replaced at WAYNE's sole option.
3. WAYNE is not responsible for any labor cost for the removal and replacement of said burner or burner components and equipment associated therewith.

4. A burner so repaired will then carry the LIMITED WARRANTY equal to the unexpired portion of the original burner LIMITED WARRANTY.
5. If inspection by WAYNE does **NOT** disclose any defect covered by this LIMITED WARRANTY, the burner or burner component(s) will be either repaired or replaced at the expense of the customer and WAYNE'S regular charges will apply.
6. If the original manufacturer of a burner component offers a warranty greater than either of our LIMITED WARRANTIES described above, then this portion will be added to our LIMITED WARRANTY.

This LIMITED WARRANTY does **NOT** cover products which have been damaged as the result of accident, abuse, misuse, neglect, improper installations, improper maintenance or failure to operate in accordance with WAYNE's written instructions.

These LIMITED WARRANTIES do not extend to anyone except the first purchaser at retail and only when the burner is in the original installation site.

**IMPLIED WARRANTIES OF MERCHANTABILITY AND FITNESS FOR A PARTICULAR PURPOSE SHALL BE LIMITED TO THE DURATION OF THE LIMITED EXPRESS WARRANTIES CONTAINED HEREIN. WAYNE EXPRESSLY DISCLAIMS AND EXCLUDES ANY LIABILITY FOR CONSEQUENTIAL OR INCIDENTAL DAMAGES OF ANY NATURE FOR BREACH OF ANY EXPRESS OR IMPLIED WARRANTY.**

Some states do not allow limitation on how long an implied warranty lasts, so the above limitation may not apply to you. Also, some states do not allow the exclusion or limitation of incidental or consequential damages, so the above limitation or exclusion may not apply to you. WAYNE neither assumes nor authorizes any person to assume for WAYNE any other liability or obligation in connection with the sale of these products. This warranty gives you specific legal rights, and you may also have other rights which vary from state to state.

