

* 18.00/[457,2] RECOMMENDED FOR REMOVAL OF BACK COVER PLATE
 T3AS-B /F / T3CSC-B /F - 9.00/[228,6] REQUIRED FOR REMOVAL OF BACK COVER PLATE
 T3DS-B /F / T3ESC-B /F / T3FSC-B /F - 9.50/[241,3] REQUIRED FOR REMOVAL OF BACK COVER PLATE

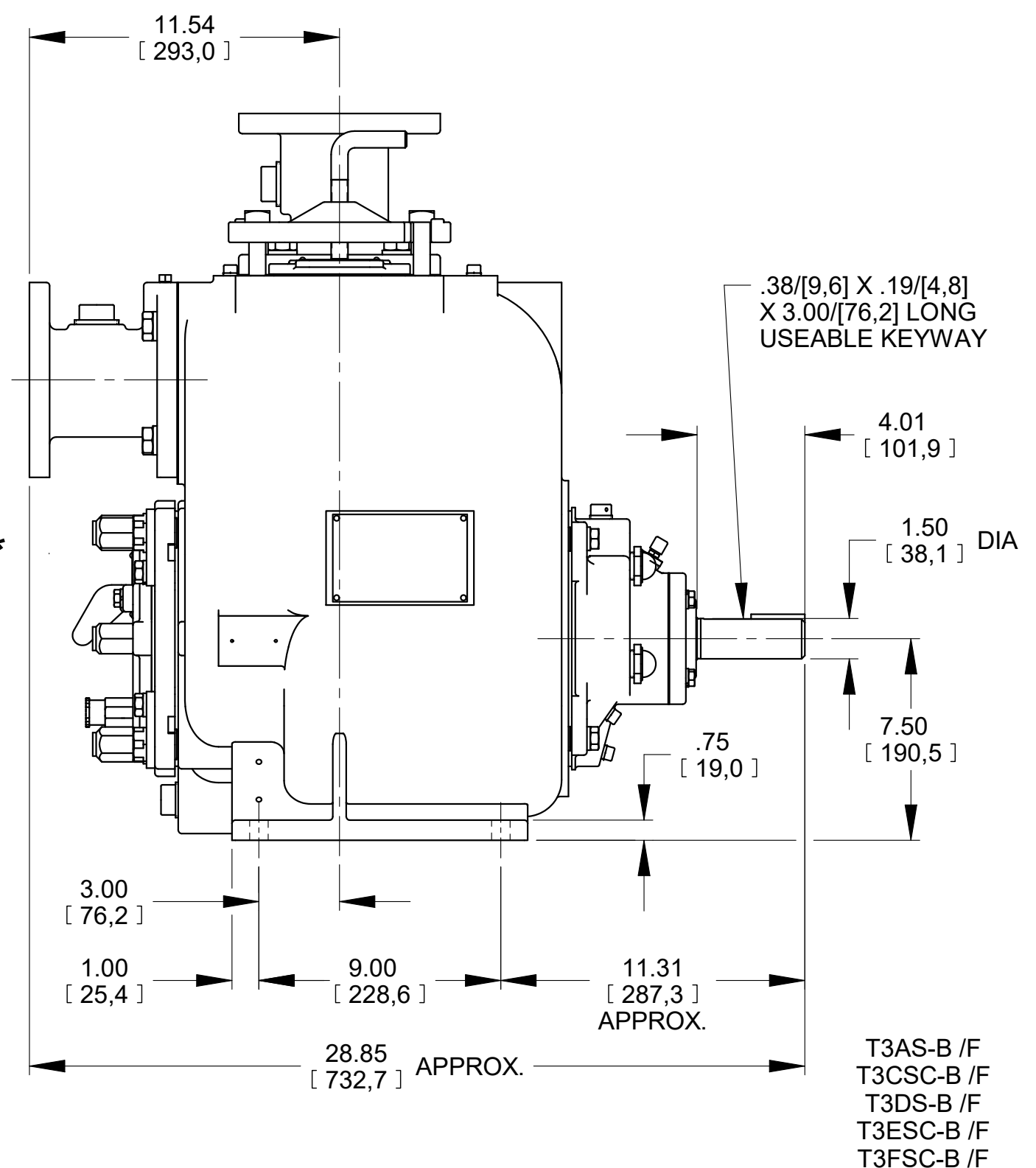
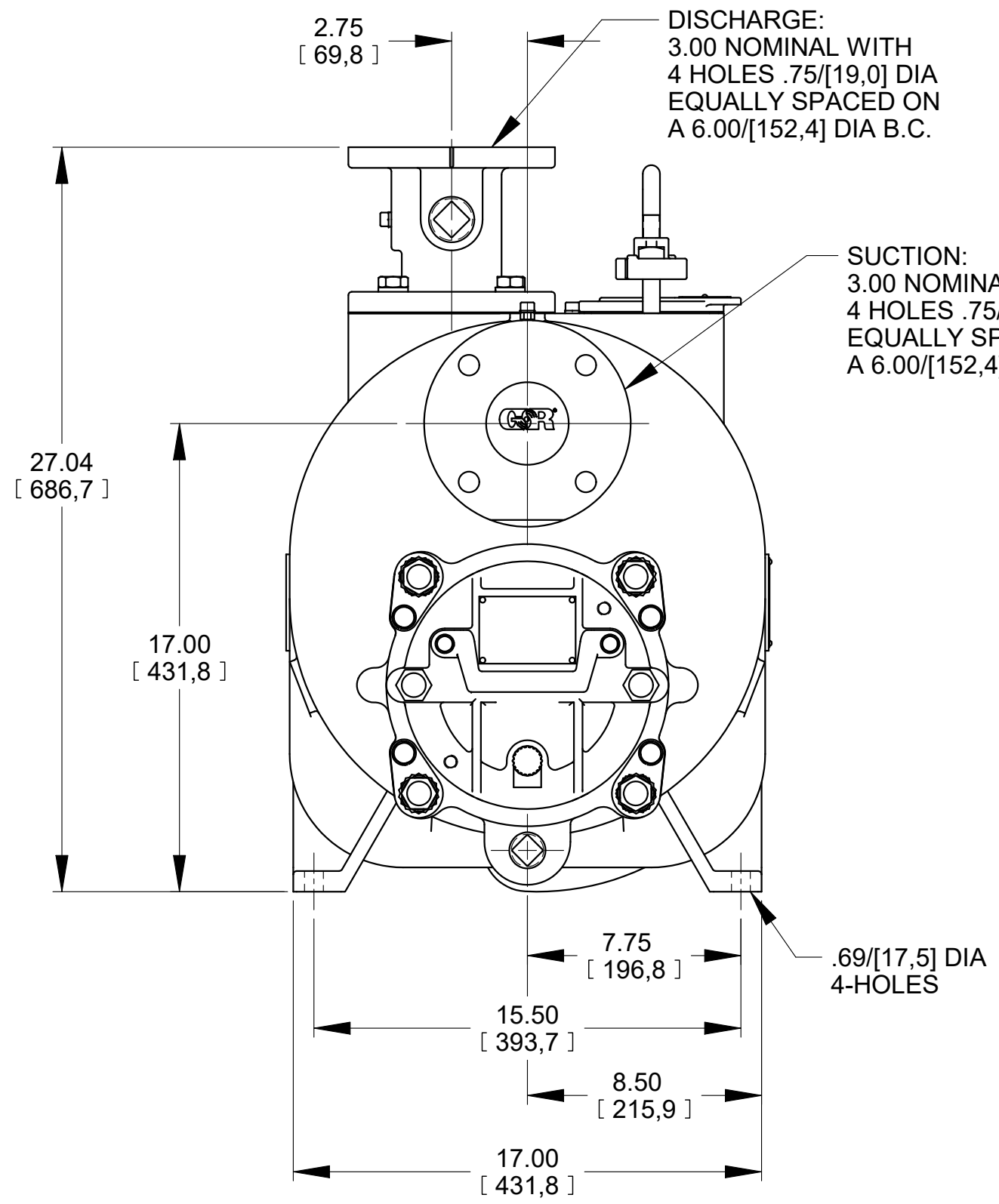

DIMENSIONS:
 INCHES
 [MILLIMETERS]

21-007

	THE GORMAN-RUPP CO. MANSFIELD, OHIO ST. THOMAS, ONTARIO		DRAWN BY JPJ	SCALE 3/16	MODEL NOTED
	DATE 11-3-14	REVISED 03-11-21	OUTLINE NUMBER 19029		