

Goose-It Installation Instructions

Overview:

The Goose-It printer controller board has been designed from the ground up to act as a reliable and flexible voucher printer that also can act as a complete bookkeeping center. Printer features, such as double size and/or red characters are used to make copycat printing more difficult (when the selected printer supports them). Also, each unit has a unique serial number, a custom message can be entered, and the date and time can be printed on every voucher. All major functions and settings can be done with the DIP switches or the on board push buttons, a cable is supplied to connect the board to a PC/Laptop or a terminal for all of the advanced functions.

Board Pin Out (See board below, all connector pin 1 denoted by square solder pad)

J1 (Inputs)

Pin 1	:	Pulse In (Pay out meter driver from game PCB)
Pin 3	:	Hand Count + (optional)
Pin 4	:	Hand Count - (optional)
Pin 5	:	Coin 2 input (For Bookkeeping)
Pin 7	:	Coin 1 input (For Bookkeeping)

J2 (power)

Pin 1 & 2	:	+5Vdc
Pin 3 & 4	:	Power Ground

J3 (outputs)

Pin 1	:	Return pulses (service credit in on game PCB)
Pin 3 & 4	:	Printer Error Lamp (5VDC lamp)

Serial (RS-232 communications)

Pin 1	:	Serial Data Out
Pin 2	:	+5Vdc
Pin 3	:	Serial Data In
Pin 4	:	Ground

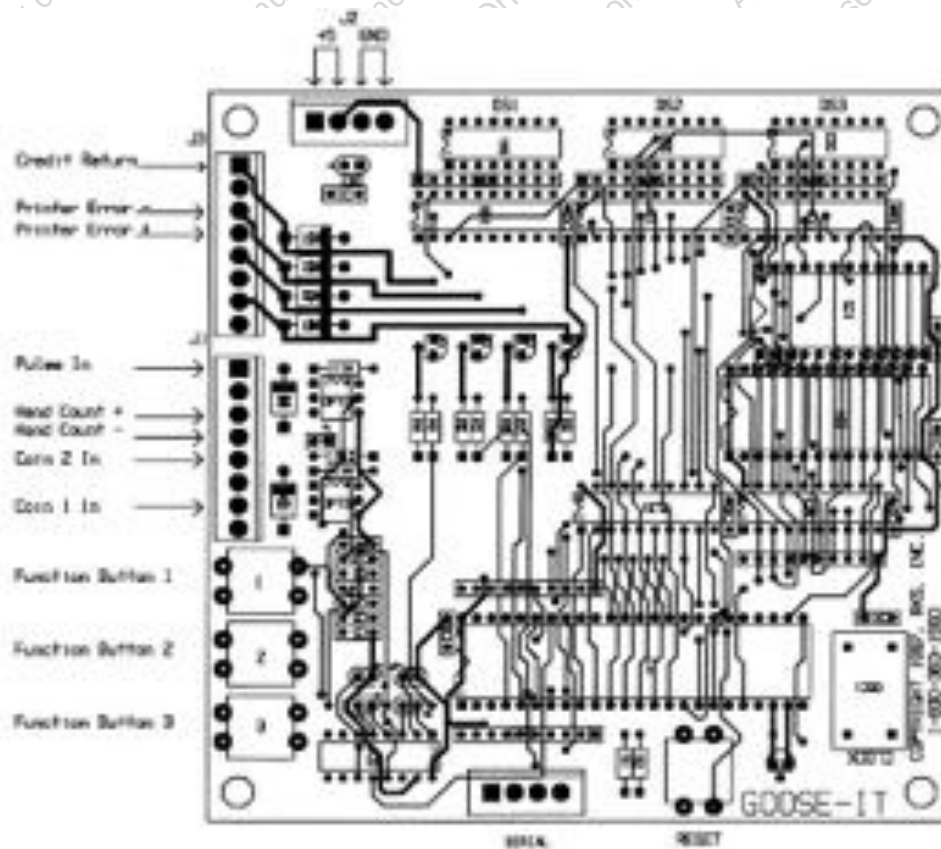

Connections:

The following connections are what is **required** for a minimal installation:

Power in (+5Vdc and Ground)

Serial cable to the printer.

Pulse in wire to the "Payout" meter. (A.k.a. keydown meter)

These optional connections may be required by certain state laws, or for your own personal tastes:

Coin 1 and Coin 2 inputs: These two inputs are to be tied into the coin and/or D.B.A. inputs to the PCB, they allow the GOOSE-IT to count the credits going into the game so they can be reported on the book keeping printout. Any low going pulse can be connected as long as there is **no more** than 5 volts present on the wire.

Credit return: This wire is used to return any unprinted credits back to the game PCB. For example: GOOSE-IT is set for 100 pulses in per point and the player cashes out 120 credits, the 20 credits will be returned to the game. If this wire is not connected the unused credits are lost.

Hand Count +/- If the Hand Count feature is enabled these wires must be connected to a lamp or signal that changes states for each hand played. On "Cherry Master" type games the start lamp is the normal connection point. If your game uses 5 volt lamps you may need to install the jumper W1 on the PCB.

Function Buttons:

- Function Button 1 : Causes the printer or terminal to display/print a summary of the current DIP switch settings, the unit serial number, and the software revision number.
- Function Button 2 : Causes the printer or terminal to display/print the unit serial number, date and time, total pulses received, total pulses returned, total pulses paid, coin 1 in, coin 2 in, and the total of the paid out (printed) data based on the current DIP switch settings. After this print out you have 30 seconds to press button 1 to clear the current book keeping totals.
- Function Button 3 : This button causes the board to go into the advanced function mode. It is assumed that a terminal is connected to the GOOSE-IT board at this time. If this button is mistakenly pressed, just press the reset button to return to normal operation. If a terminal is attached you will get a menu showing the available choices. Currently the choices allow for the entering, or modification of the date/time clock, and the custom message system.
- Reset Button : This button does a master reset of the system, at which time the printer will print a stub that shows the date and time of the reset.
- Combinations : Simultaneous pressing Button 1 **and** 3 will do a total memory reset on the battery backed memory. Pressing Button 1 **and** 2 will print a duplicate of the last voucher in memory.

Communications Settings:

- The basic RS-232 parameters are : 9600B, 8 Data Bits, 1 Stop Bit, NO Parity.
A new line is the combination CR/LF.
If the printer double spaces it's lines check the CR setting.
Make sure the printer and/or your terminal package is set for these values. Also, make sure your terminal software is set up for NO flow control.

Recommended Printers:

Citizen iDP3551 : Friction Feed, 40 Column, RS-232, International Character Set, 120VAC, character, w/battery backup, 7K buffer, Auto-cutter, and 2 color printing.

Ithaca 70 Series w/auto-cutter.

DIP Switch Function Summary:

Pulses in to equal 1 point : The “point” is an internal representation of the credits in divided by this number. Further processing may be done on this number by the next setting.

Each Point is worth : The above number of “points” is multiplied by this number to achieve the printed value. For example : setting the “pulses in equal to 1 point” to 100 and “each point is worth” to 5 makes 100 pulses in equal to 5 dollars or 5 points.

Points equal to : Is the printed point value going to be MONEY or POINTS.

Money equal to : If the above is set to MONEY then is the value DOLLARS or CENTS. This setting has no effect if points are equal to POINTS.

Use Custom Message : Turns the 3 line custom message, that can be entered with a computer or terminal, on or off. This is handy if the game is being moved to a new location and a terminal isn’t available to change the message.

Use Date & Time : Turns on or off the printing of the date and time stored in the battery backed RAM.

Use Signature Line : Turns on or off the printing of the Customer Signature line. This setting is forced to ON anytime a “Law” is selected.

State Laws : Adds the listed states redemption law to the printed voucher.

Hand Count : Should the software count the number hands the player played and use that number as the maximum number of “points” to print out. The remaining credits will be returned to the game.

Hand Timeout : This is an idle timer that is running anytime there are hands played but the hand count signal is not active. This allows a player to add credits after a game over, or a bonus round being played not to dump the players hands.

Printer Type : Sets the board to take advantage of any special features a particular printer may have. For example if you are using the Citizens printer the board will use double sized and red printing for selected areas to make copycat printing more difficult.

Goose-It DIP Switch Settings V3.60

Function	Value	DIP Switch 1								DIP Switch 2								DIP Switch 3							
		1	2	3	4	5	6	7	8	1	2	3	4	5	6	7	8	1	2	3	4	5	6	7	8
Pulses in to equal 1 point	1	0	0	0	0	0																			
	2	1	0	0	0	0																			
	4	0	1	0	0	0																			
	5	1	1	0	0	0																			
	8	0	0	1	0	0																			
	10	1	0	1	0	0																			
	15	0	1	1	0	0																			
	20	1	1	1	0	0																			
	25	0	0	0	1	0																			
	40	1	0	0	1	0																			
	50	0	1	0	1	0																			
	75	1	1	0	1	0																			
	100	0	0	1	1	0																			
	150	1	0	1	1	0																			
	200	0	1	1	1	0																			
	250	1	1	1	1	0																			
	400	0	0	0	0	1																			
500	1	0	0	0	1																				
1000	0	1	0	0	1																				
2000	1	1	0	0	1																				
2500	0	0	1	0	1																				
5000	1	0	1	0	1																				
Each point is worth (It's Printed) (Value)	1						0	0	0	0															
	2						1	0	0	0															
	5						0	1	0	0															
	10						1	1	0	0															
	15						0	0	1	0															
	20						1	0	1	0															
	25						0	1	1	0															
	50						1	1	1	0															
	75						0	0	0	1															
	100						1	0	0	1															
	150						0	1	0	1															
	200						1	1	0	1															
250						0	0	1	1																
400						1	0	1	1																
500						0	1	1	1																
1000						1	1	1	1																
Multiple Vouchers	NO																							0	
	YES																							1	

SEE
NEXT
SHEET

