

F1 Goose Installation Instructions

Overview:

The F1 Goose printer controller board has been designed from the ground up to act as a reliable and flexible voucher printer that also can act as a complete bookkeeping center. Printer features, such as double size and/or red characters are used to make copycat printing more difficult (when the selected printer supports them). Also, each unit has a unique serial number, a custom message can be entered, and the date and time can be printed on every voucher. All major functions and settings can be done with the DIP switches or the on board push buttons, a cable is supplied to connect the board to a PC/Laptop or a terminal for all of the advanced functions.

Board Pin Out (See board below, all connectors pin 1 denoted by square solder pad)

J1 (Inputs)

Pin 1	:	Pulse In (Pay out meter driver from game PCB)
Pin 5	:	Coin 2 input (For Bookkeeping)
Pin 7	:	Coin 1 input (For Bookkeeping)

J2 (power)

Pin 1 & 2	:	Power Ground
Pin 3 & 4	:	+5VDC

J3 (outputs)

Pin 1	:	Return pulses (service credit in on game PCB)
Pin 3	:	Printer Error Lamp (5VDC lamp)
Pin 4	:	+5VDC for error Lamp
Pin 5	:	System/DBA Enable active low

Serial Data (RS-232 communications)
DB9 Standard PC Pin out.

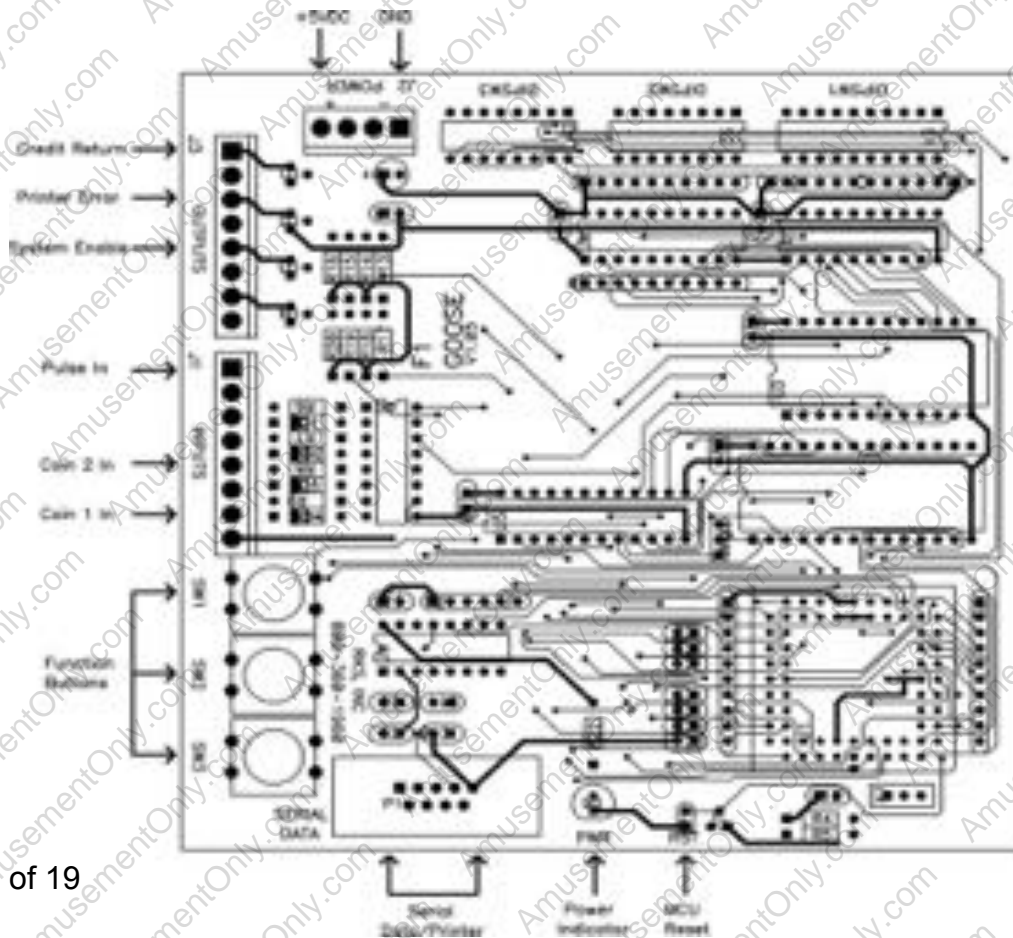

The F1 Goose is an enhanced replacement of the Goose-It PCB brought about because Motorola (now Freescale) issued an end of life for the MCU used on the older board. This gave us the opportunity to bring the technology up to date, add some functionality, that was used on some of the custom software versions we made, and to drop some of the unused features of the old system.

Features :

- Same form factor as the old system.
- Same pin out as the old system.
- Same Button Commands as the old system, with some additions.
- System now stores and prints a summary of the last 15 vouchers.
- The system now has a set of permanent books that print after the temporary data.
- XON/XOFF printer flow control is now replaced with hardware DSR flow control.
- The unit now knows if the printer is missing or offline from power up.
- DIP Switch 1 is now expanded to a 10 position unit. This allowed us to put all of the voucher amounts to be on a single DIP switch and we had enough room to add all of the custom values people have asked for over the years with room to spare.
- There is now a power indicator on the PCB.
- The PCB now uses an off the shelf 9 to 25 pin cable available from us and available at any local Radio Shack (part #26-269).
- The programming cable is an off the shelf 9 to 9 cable available from us and available at any local Radio Shack (part# 26-152).
- The Custom Header data is stored in the MCU in EEPROM, not the battery backed RAM. This all but eliminates the possibility of losing the header.
- The User Entered Law is stored in the MCU in EEPROM, not the battery backed RAM.
- The system now has more protections on the battery backed RAM to reduce the chances of corrupt book keeping data.
- The outputs no longer have "protection" diodes going to 5V. This allows compatibility with some of the newer boards that have 12V I/O without having to cut off diodes.
- The hand count feature has been dropped. This functionality was added to fill the gap at a time that it wasn't readily available on the main game boards. It is now a very common main game feature and that allowed us to reclaim the option switches for other uses.
- If the unit is left in any mode, other than operating mode, (setup or a prompt for user input) the system will reset and continue with any owed vouchers after 60 seconds of inactivity.

Button Combinations :

- 1 : Print the system status. Lets you know how your DIP switches are set.
- 2 : Print the system book keeping. Prompts for clear or continue.
- 3 : Enter Setup Mode. For setting headers, clock, law.
- 1 & 2 : Prints a summary of the last 15 vouchers.
- 1 & 3 : Clears out the temporary books with out printing them.
- 2 & 3 : Clears out the user entered header
- 1 & 2 & 3 : Clears out the user entered law.

Connections:

The following connections are **required** for a minimal installation:

- Power in (+5Vdc and Ground)
- Serial cable to the printer.
- Pulse in wire to the "Payout" meter. (A.k.a. keydown meter)

These optional connections may be required by certain state laws, or for your own personal tastes:

Coin 1 and Coin 2 inputs: These two inputs are to be tied into the coin and/or D.B.A. inputs to the PCB, they allow the F1 Goose to count the credits going into the game so they can be reported on the book keeping printout. Any low going pulse can be connected as long as there is **no more** than 50 volts present on the wire when it is inactive.

Credit return: This wire is used to return any un-printed credits back to the game PCB. For example: F1 Goose is set for 100 pulses in per point and the player cashes out 120 credits, the 20 credits will be returned to the game. If this wire is not connected the unused credits are lost.

Function Buttons:

- Function Button 1 : Causes the printer or terminal to display/print a summary of the current DIP switch settings, the unit serial number, and the software revision number.
- Function Button 2 : Causes the printer or terminal to display/print the unit serial number, date and time, total pulses received, total pulses returned, total pulses paid, coin 1 in, coin 2 in, and the total of the paid out (printed) data based on the current DIP switch settings. After this print out you have 30 seconds to press button 1 to clear the current book keeping totals.
- Function Button 3 : This button causes the board to go to into the advanced function mode. It is assumed that a terminal is connected to the F1 Goose board at this time. If this button is mistakenly pressed, just press the reset button to return to normal operation. If a terminal is attached you will get a menu showing the available choices. Currently the choices allow for the entering, or modification of the date/time clock, and the custom message system.
- Combinations :
1 & 2 : Prints a summary of the last 15 vouchers.
1 & 3 : Clears out the temporary books with out printing them..
2 & 3 : Clears out the user entered header
1 & 2 & 3 : Clears out the user entered law.

Communications Settings:

- The basic RS-232 parameters are : 9600B, 8 Data Bits, 1 Stop Bit, NO Parity.
A new line is the combination CR/LF.
If the printer double spaces it's lines check the CR setting.
Make sure the printer and/or your terminal package is set for these values. Also, make sure your terminal software is set up for NO flow control.

Recommended Printers:

Citizen iDP3541/iDP3551

: Friction Feed, 40 Column, RS-232, International Character Set, 120VAC, character, w/battery backup, 7K buffer, Auto-cutter, and 2 color printing.

Ithaca 70 Series w/auto-cutter.

DIP Switch Function Summary:

Pulses in to get a printout :

This setting is the minimum number of pulses required to get a voucher any amount under this number will not be printed. For example, if you have a nickel machine and you want to limit the collect to \$5.00 vouchers, you would set this number to 100.

What is the printed value :

When the above number of is reached what the printed value will be. For example : setting the "pulses in to get a printout to 100 and "What is the printed value" to 5 makes 100 pulses in equal to 5 dollars, 5 points, or 5 tickets. Depending on the next setting.

Printed value equal to :

Is the printed point value going to be MONEY, POINTS, or TICKETS..

Money equal to :

If the above is set to MONEY then is the value DOLLARS or CENTS. This setting has no effect if points are equal to POINTS or TICKETS.

Multi-Voucher :

Instead of printing one big voucher, should the unit break the amount into smaller units.

Max Voucher Value :

If Multi-Voucher is ON this sets the maximum amount printed on a single voucher.

Pulse in timeout :

This is the number of seconds the unit will wait until it considers the pulses in from the machine to be complete. The 10 second setting is used for some games that can have long pauses in their outputs.

Use Custom Message :

Turns the 4 line custom message, that can be entered with a computer or terminal, on or off. This is handy if the game is being moved to a new location and a terminal isn't available to change the message.

Use Date & Time :

Turns on or off the printing of the date and time stored in the battery backed RAM.

State Laws :

Adds the listed states redemption law to the printed voucher.

Printer Type :

Sets the board to take advantage of any special features a particular printer may have. For example if you are using the Citizens printer the board will use double sized and red printing for selected areas to make copycat printing more difficult.

F1 Goose V1.00

Description	Value	DIP Switch 1 (0 = OFF / 1 = ON)									
		1	2	3	4	5	6	7	8	9	10
<p style="text-align: center;">Pulses in to Get a Print Out</p> <p>(Pulses per point)</p>	1	0	0	0	0	0					
	2	1	0	0	0	0					
	3	0	1	0	0	0					
	4	1	1	0	0	0					
	5	0	0	1	0	0					
	6	1	0	1	0	0					
	8	0	1	1	0	0					
	10	1	1	1	0	0					
	15	0	0	0	1	0					
	16	1	0	0	1	0					
	20	0	1	0	1	0					
	25	1	1	0	1	0					
	40	0	0	1	1	0					
	50	1	0	1	1	0					
	60	0	1	1	1	0					
	75	1	1	1	1	0					
	80	0	0	0	0	1					
	100	1	0	0	0	1					
	120	0	1	0	0	1					
	150	1	1	0	0	1					
	200	0	0	1	0	1					
	250	1	0	1	0	1					
	400	0	1	1	0	1					
	500	1	1	1	0	1					
	1000	0	0	0	1	1					
	2000	1	0	0	1	1					
2500	0	1	0	1	1						
5000	1	1	0	1	1						
Custom 1	0	0	1	1	1						
Custom 2	1	0	1	1	1						
Custom 3	0	1	1	1	1						
Custom 4	1	1	1	1	1						

F1 Goose V1.00

Description	Value	DIP Switch 1 (0 = OFF / 1 = ON)									
		1	2	3	4	5	6	7	8	9	10
<p>What is the Printed Value</p> <p>(pp_mult)</p>	1						0	0	0	0	0
	2						1	0	0	0	0
	3						0	1	0	0	0
	4						1	1	0	0	0
	5						0	0	1	0	0
	6						1	0	1	0	0
	10						0	1	1	0	0
	15						1	1	1	0	0
	20						0	0	0	1	0
	25						1	0	0	1	0
	40						0	1	0	1	0
	50						1	1	0	1	0
	60						0	0	1	1	0
	75						1	0	1	1	0
	100						0	1	1	1	0
	150						1	1	1	1	0
	200						0	0	0	0	1
	250						1	0	0	0	1
	400						0	1	0	0	1
	500						1	1	0	0	1
	1000						0	0	1	0	1
	Custom						1	0	1	0	1
	Custom						0	1	1	0	1
	Custom						1	1	1	0	1
	Custom						0	0	0	1	1
Custom						1	0	0	1	1	
Custom						0	1	0	1	1	
Custom						1	1	0	1	1	
Custom						0	0	1	1	1	
Custom						1	0	1	1	1	
Custom						0	1	1	1	1	
Custom						1	1	1	1	1	

F1 Goose V1.00									
Description	Value	DIP Switch 2							
		1	2	3	4	5	6	7	8
Multi-Voucher	OFF	0							
	ON	1							
Max Voucher Value if Multi-Voucher On	1		0	0	0				
	4		1	0	0				
	5		0	1	0				
	6		1	1	0				
	10		0	0	1				
	20		1	0	1				
	25		0	1	1				
	Custom		1	1	1				
Printed Value Equal To	MONEY					0	0		
	POINTS					1	0		
	TICKETS					0	1		
	Nothing					1	1		
Money Equal to	DOLLARS							0	
	CENTS							1	
Pulse In Timeout	2 Sec								0
	10 Sec								1

F1 Goose V1.00									
Description	Value	DIP Switch 3							
		1	2	3	4	5	6	7	8
Use Custom Message	NO	0							
	YES	1							
Use Date and Time	NO		0						
	YES		1						
Use State Specific Law	NONE			0	0				
	User Entered			1	0				
	GA			0	1				
	Custom			1	1				
Returned Credit Divisor	1					0	0		
	5					1	0		
	25					0	1		
	100					1	1		
Printer Type	Generic							0	0
	Citizen 35XX							1	0
	Epson 90							1	0
	Ithaca 70							0	1
	Star							1	1

Citizen 3541

Recommended settings

11-1. Setting DIP Switch DS1

No.	Function	OFF	ON	
1	Auto Cutter	NO	YES	ON
2	International country	(Refer to table below)		OFF
3	switching			OFF
4	Input buffer	7K Bytes	2 Lines	OFF
5	Character direction	Normal	Inverted	OFF
6	CR cord	CR	CR + LF	OFF
7	Mode	Character	Graphic	OFF
8	SEL / DESEL at power on *	SELECT	DESELECT	OFF

Notes: *1) Setting is variable, depending on the type of printer.

No.	USA	FRANCE	GERMAN Y	ENGLAND
2	OFF	ON	OFF	ON
3	OFF	OFF	ON	ON

11-2 Setting DIP Switch DS2

1) Serial interface only

No.	Function	OFF	ON	
1	Word length setting	8 bits	7 bits	OFF
2	Parity check	YES	NO	ON
3	Parity condition	ODD	EVEN	OFF
4	Not used			OFF
5				ON
6	Baud rate setting	(Refer to the table below)		ON
7				ON
8				OFF

Power off and remove the printer cover before setting the Dip-Switches.

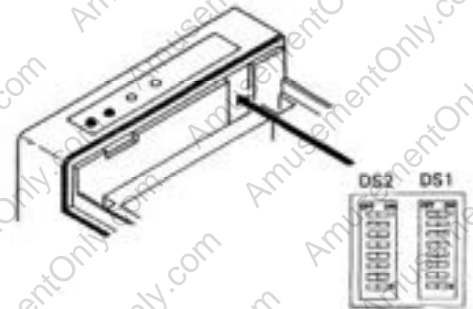

bps No.	110	150	300	600	1200	2400	4800	9600
5	OFF	ON	OFF	ON	OFF	ON	OFF	ON
6	OFF	OFF	ON	ON	OFF	OFF	ON	ON
7	OFF	OFF	OFF	OFF	ON	ON	ON	ON
8	OFF	OFF	OFF	OFF	OFF	OFF	OFF	OFF

DIP Switch Setting

DIP Switch 1

No.	Function	ON	OFF
DSW1-1	Auto refresh	Yes	No
DSW1-2	International characters	ON	ON
DSW1-3	"	ON	ON
DSW1-4	"	ON	ON
DSW1-5	CSM normalized (DIP 3030 (DIP 3140) systems)	CSM mode	CSM1 mode
DSW1-6	CR mode	See the table below	OFF
DSW1-7	Mechanism type	Graphic	Character
DSW1-8	Buffer size	UK bytes	Other bytes
DSW1-9	Operation mode	See the table below	OFF
DSW1-10	"	See the table below	OFF

*1, *3 Depends on the type.

*2 Depends on the destination.

*4 Indicator only when CSM mode is selected with DSW1-8 and -10. For details see "CSM Mode" in "PRINT CONTROL FUNCTIONS".

International Character Selection

Country	DSW1-2	DSW1-3	DSW1-4
U.S.A.	ON	ON	ON
France	OFF	ON	ON
Germany	ON	OFF	ON
U.K.	OFF	OFF	ON
Denmark	ON	ON	OFF
Sweden	OFF	ON	OFF
Italy	ON	OFF	OFF
Japan	OFF	OFF	OFF

Character Code Selection

ESCAPE mode	ESM mode	Star mode
Code J17	CSM	Star
Code 850	Code 850	Code 850
"	"	"
"	"	"
"	"	"
"	"	"
Seikenshu (Japanese)	CSM (Japanese)	Star (Japanese)

See the "International Character Code Table and Character Codes Table".

CR mode (DSW1-6)

Mode	DSW1-6	ON
CSM	CR-LF	CR
STAR	CR-LF	Ignored
ESCAPE	CR-LF	CR

Operation Mode (DSW1-8, DSW1-10)

Operation Mode	DSW1-8	DSW1-10
CSM	OFF	OFF
ESCAPE	ON	OFF
STAR	OFF	ON
STAR Auto CR	ON	ON

2)

DIP Switch 2

No.	Function	ON	OFF
DSW2-1	Bar length	4 bits	7 bits
DSW2-2	Parity	No	Yes
DSW2-3	CR-LF type	CR	CR+LF
DSW2-4	Communication mode	DTRMODE	MSM-COPY
DSW2-5	Read rate	See the table below	OFF
DSW2-6	"	See the table below	OFF
DSW2-7	"	See the table below	OFF
DSW2-8	Unused	-	-

Read rate

Read rate	DSW2-6	DSW2-7	DSW2-8
150	OFF	OFF	OFF
300	OFF	OFF	ON
600	ON	ON	OFF
1200	ON	ON	ON
2400	ON	OFF	OFF
4800	ON	OFF	ON
9600	ON	ON	OFF
19200	ON	ON	ON

Citizen iDP-3551 Settings

Woosim Printer Settings



Denotes
Required Setting

ADP-300 MANUAL

Dip Switch Settings

This table gives the definition for the DIP switch settings.

Function	Setting	SW3										SW4					
		1	2	3	4	5	6	7	8	9	10	1	2				
S E R I A L	Emulation	Epson TM-U200	OFF	OFF													
		Citizen DP3540	ON	OFF													
		Verifone P900	OFF	ON													
		Star SP200	ON	ON													
	CR Character	CR=CR Only			OFF												
		CR=CR + LF			ON												
	CPL	40/33 Char/Line				OFF											
		42/35 Char/Line				ON											
	Flow Control	XON/XOFF					ON										
		DTR/DSR					OFF										
Baud Rate	38400						OFF		OFF	OFF							
	19200						ON		OFF	OFF							
	9600						OFF		ON	OFF							
	4800						ON		ON	OFF							
	2400						OFF		OFF	ON							
	1200						ON		OFF	ON							
	600						OFF		ON	ON							
	300						ON		ON	ON							
Data Bits	8 Bits None												OFF				
	7 Bits Odd											OFF	ON				
Parity	7 Bits Even											ON	ON				
Cutter	Not Install												OFF				
	Install												ON				
2 Color	Not Install														OFF		
	Install														ON		
P A R A L L E L	Emulation	Epson TM-U200	OFF	OFF													
		Citizen DP3540	ON	OFF													
	CR Character	CR=CR Only			OFF												
		CR=CR + LF			ON												
	CPL	40/33 Char/Line				OFF											
	42/35 Char/Line				ON												
Cutter	Not Install									OFF							
	Install									ON							
2 Color	Not Install										OFF						
	Install										ON						

Ithaca 70 Series

SW 1

Switch	Function	On	Off
1	Parity Type	Odd	Even
2	Parity	* No Parity	Parity
3	Data Bits	* 8	7
4	Protocol	* READY/BUSY	XON/XOFF
5	Test Select	Circuit	Monitor
6	Mode	Printing	Testing

ON
OFF
ON
ON
OFF
ON

Switch	Function	Selection	Switch 7	Switch 8
7, 8	Busy Line	* DTR - (Pin 20)	On	On
		RTS - (Pin 4)	On	Off
		SSD - (Pin 11)	Off	On
		SSD + (Pin 11)	Off	Off

 ON

SW 2

Switch	Function	Selection			
		Rate (bps)	Switch 1	Switch 2	Switch 3
1, 2, 3	Baud Rate	19,200	On	On	On
		* 9,600	Off	On	On
		4,800	Off	Off	On
		2,400	Off	Off	On
		1,200	On	On	Off
		600	Off	On	Off
		300	On	Off	Off
		110	Off	Off	Off
* Factory Settings					

 OFF
ON

Switch	Function	Selection	
		On	Off
4	DSR	Active	Inactive
5	Buffer Threshold	* 32 Bytes	256 Bytes
6	Busy Signal Timing	* 200 ms	1 second
7	Not Used		
8	Not Used		
* Factory Settings			

ON
OFF
OFF

“Omega” Coin Meter Output

Tap off U59 Pin 2



F1-Goose

Setup Communications with PC

- 1.) On your PC, go to the start menu. Select from tool bar the following (in this order): **Programs**, then **Accessories**, then **Communications**. Double click on the **Hyper-Terminal** to create a new connection.
- 2.) When prompted, give the terminal a name and choose an icon for it. Next, a “Connect to” window appears. At the **Connect using** or **Direct to** prompt, and select your free COM port. Usually COM 1. Select **OK**.
- 3.) Next, a “COM (X) Properties” window appears for your port settings. Set your **Bits per Second** (baud rate) to 9600. Now set your **Data bits** to 8. Move on to **Parity**, select None. **Stop bits** should be set at 1, and **Flow Control** should be none. Let’s review, you should see the following in the right-hand boxes from top to bottom: 9600, 8, None, 1, and None. If this is correct, select **OK**. If not, correct any mistakes and then select **OK**. You should now have a terminal screen with a blinking cursor. In the bottom left corner, you should see that you are connected.

Note: If you did not connect, and it tells you that it could not connect to the COM port you selected, simply select **Properties** from the **File** pull down menu. Now change your COM port at the **Connect using** or **Direct to** prompt.

- 4.) Now, connect the F1-Goose to the PC with the terminal cable provided, and apply power to the F1-Goose. You should see a power up message along with the serial number of the board. Press button number 3 to put the F1-Goose into setup mode and follow the on-screen prompts. At this point, all data is entered via your PC keyboard. When your time, date, and message have been entered and verified, exit setup mode and power down. Your board is now programmed and ready to be placed on location.

If you should experience any problems not resolved via the enclose troubleshooting guides, please feel free to call RKS Tech Support for further assistance.

F1-Goose And PRINTER TROUBLESHOOTING

Always check that the “pulse in” wire is connected properly and is the correct wire (I.E.: On the Cherry Master type games, the “pulse in” should be connected to Pin 28 (parts side) wire, the out meter pulse.

If your main game board is counting points out for a ticket, then set the F1-Goose to a one-to-one setting. If both boards are set to count points out, no ticket will appear.

If printer prints “PD ...” and runs continuously on power up:

- A) hold down both switches on the printer, then turn it off and back on. The printer should print at ticket of “garbage” to clear the buffer. N.C. Reset the F1-Goose board and try again.
- B) This problem may also be produced by an incorrect baud rate on your printer to terminal connection. Check baud rate for correct setting of 9600 baud.

Check printer version (model) number. The Citizen 3541 and the Citizen 3551 have different settings. Your F1-Goose instructions include settings for both.

If the printer beeps 4 times, pauses, then beeps 4 times again when you try to print a ticket, check the paper roll to be sure it is installed properly. The beep is signaling that the switches by the paper roll are not made. If the slide release for the paper is not completely flush with the edge of the printer body, it will not make the switch activate.

Try using the “coin in meter” wire for your credits connections instead of the regular coin wire. (8-Line type games Pin 23)

If your game is set to play for pennies,

- A) be sure that the connection for “pulses out” is in the proper position. Some games’ boards use different connections for the “pulses out” on different coin settings.
- B) be sure that your “coin in” wire is also in the proper position in the edge connector. (I.E.: On the Cherry Master type games, the “coin in” wire is moved to Pin19 on the solder side for penny operation.)

If you get tickets printed for wrong value:

- A) check settings of DIP switches between F1-Goose and the main game board. *Each game board sets up differently.* Therefore, the F1-Goose sets up differently for each to achieve the type of ticket you want. (I.E.: 100 pts = \$5, 500 pts = \$5)

Helpful Hint: Copy F1-Goose DIP switch settings for each type of game board and record the correct settings for each. (I.E.: Cherry Master, Cherry 96, Poker Games, etc. each have their own sheet with correct settings kept in a safe and convenient location.)

- B) Check to see if game board is set for money instead of points for ticket value. (I.E.: A Cherry 96 board set to play pennies will print a ticket for 45,655 points when set to print out point.) Change the F1-Goose settings to dollars to get the proper value ticket - \$5.00 for 500 points.

If you get no credit returns:

be sure that you are actually connecting to a service input on the edge connector. Some game boards have a slightly different pinout, and some no service in. In that case, you would need to use one of the alternate “coin in” connections.

Where using the F1-Goose for main book-keeping and installing an equalizer in line, you must add diodes to the equalizer connections of J2 with the banded end of the diode installed toward the voltage connection. With no diodes the meters will give a half click on power up and not function.

Common game boards requiring this modification include Triple Jack, Magical Odds, Mystery J and B. This problem will be fixed on the remainder of the equalizers, but your existing boards may need to be modified.

F1-Goose and Printer Troubleshooting (Continued)

Magic Bomb Setup

Nickels

Coin in: 1 coin 5 credits

Key in: 1 turn 100 credits

Actually sets the number of points per ticket or voucher. This setting will give you 1 pulse for every 100 points. It takes credits off in 100 credit increments and keeps unused points on the game.

Coin Out: Leave set at 1 pay 1 credit

Key Out: As key in

Pennies

Coin in: 1 coin 25 credits

Key in: 1 turn 500 credits

Coin Out: Leave set at 1 pay 1 credit

Key Out: As key in

Set F1-Goose Board

Dip Switch 1 - All off except # 7

This gives you a setting for 1 pulse = a five dollar voucher.

POSSIBLE F1-Goose SETTINGS

When setting up the F1-Goose, Set Dip Switch #1, Position 1-5 for the number of coins in to equal the ticket value. Set Dip Switch #1 position 6-8 and Dip Switch #2 position 1 for the dollar value of the ticket.

Most 8 Line Type Boards

For Example:

- K** Nickle play = Dip Switch #1 positions 3 & 4 on = 100 nickels,
and position 7 on = \$5 ticket. $100 \times .05 = \$5.00$
- K** Quarter play = Dip Switch #1 positions 1, 2, & 3 on = 20 quarters,
and position 7 on = \$5 ticket. $20 \times .25 = \$5.00$
- K** Dime play = Dip Switch #1 positions 2 & 4 on = 50 dimes,
and position 7 on = \$5 ticket. $50 \times .10 = \$5.00$
- K** Penny play = Dip Switch #1 positions 1 & 5 on = 500 pennies,
and position 7 on = \$5 ticket. $500 \times .01 = \$5.00$

SETTINGS WITH TRIPLE JACK Version 1.4

Triple Jack with Hands Count Disabled

Based on 4 pulses per dollar from the bill acceptor and the credit return on the F1-Goose not used. If the credit return must be used, call for info on setups.

- K** Penny Play = \$5.00 ticket 500 credits = ticket
On F1-Goose: set Dip Switch #1 positions 1, 2, & 7 on
On T/J: set Dip Switch #3 Position 1, 2, & 3 off
 set Dip Switch #5 Position 3, 4, 5, 6, & 7 off and 8 on
 set Dip Switch #7 Position 1, 2, 5, 6, 7, & 8 off
- K** Nickel Play = \$5.00 ticket 100 credits = ticket
On F1-Goose: set Dip Switch #1 position 7 on
On T/J: set Dip Switch #3 Position 1 & 2 off and 3 on
 set Dip Switch #5 Position 3, 4, 5, 6, & 7 off and 8 on
 set Dip Switch #7 Position 1, 2, 5, 7, & 8 off and 6 on
- K** Dime Play = \$5.00 ticket 50 credits = ticket
On F1-Goose: set Dip Switch #1 positions 1, 2, 3, & 7 on
On T/J: set Dip Switch #3 Position 1 & 2 off and 3 on
 set Dip Switch #5 Position 3, 4, 5, & 7 off and 6 & 8 on
 set Dip Switch #7 Position 2, 5, & 8 off 1, 6, & 7 on

***Note: The bill acceptor must be set at 2 pulses per dollar.**

POSSIBLE F1-Goose SETTINGS (Continued)

- K** Quarter Play = \$5.00 ticket 20 credits = ticket
On F1-Goose: set Dip Switch #1 positions 1 & 7 on
On T/J: set Dip Switch #3 Position 1, 2, & 3 on
 set Dip Switch #5 Position 3, 4, 6, & 7 off and 5&8 on
 set Dip Switch #7 Position 1, 2, 6, & 7 off 5 & 8 on

Triple Jack with Hands Count Enabled

Based on 4 pulses per dollar from the bill acceptor and the credit return on the F1-Goose cannot be used.

- K** Penny Play = \$5.00 ticket 500 credits = ticket
On F1-Goose: set Dip Switch #1 positions 1, 5, & 7 on
On T/J: set Dip Switch #3 Positions 1, 2, & 3 off
 set Dip Switch #5 Positions 3, 4, 5, & 7 off and 6 & 8 on
 set Dip Switch #7 Positions 2, 5, 6, 7, & 8 off and 1 on

- K** Nickel Play = \$5.00 ticket 100 credits = ticket
On F1-Goose: set Dip Switch #1 positions 3, 4, & 7 on
On T/J: set Dip Switch #3 Position 1 & 2 off and 3 on
 set Dip Switch #5 Position 3, 4, 5, & 7 off and 6 & 8 on
 set Dip Switch #7 Position 2, 5, 7, & 8 off and 1 & 6 on

- K** Dime Play = \$5.00 ticket 50 credits = ticket
On F1-Goose: set Dip Switch #1 positions 1, 2, 3, & 7 on
On T/J: set Dip Switch #3 Position 1 & 2 off and 3 on
 set Dip Switch #5 Position 3, 4, 5, & 7 off and 6 & 8 on
 set Dip Switch #7 Position 2, 5, & 8 off 1,6, & 7 on

***Note: The bill acceptor must be set at 2 pulses per dollar.**

- K** Quarter Play = \$5.00 ticket 20 credits = ticket
On F1-Goose: set Dip Switch #1 positions 1,2, 3, & 7 on
On T/J: set Dip Switch #3 Position 1, 2 & 3 on
 set Dip Switch #5 Position 3, 4, 5, & 7 off and 6 & 8 on
 set Dip Switch #7 Position 2, 6, & 7 off 1, 5, & 8 on

- K** Note that the Triple Jack is set to use the hands count.
It will only count 1 to 1. The F1-Goose must be set to count the ticket value per 1 point. (I.E.: 1 point = \$5.00)

Possible F1-Goose Settings (Continued-pg2)

For Cherry Masters, No Special Applications 100 points = \$5.00

Dip Switch #1

Switches # 3,4, &7 on = 100 pulses in = 1 point, and each point = 5 or \$5.00

Switches # 2 & 3 lets you customize your setup

For Cherry 96, Fruit Bonus 96, Etc Type Boards

If you set up the game board to count the credits out for a ticket you must set up the F1-Goose to a one to one, so that it prints a ticket for each point it receives from the main game board.

Dip Switch # 1

Switch #7 on and all the rest off. Some of these boards require yo to print tickets in money mode which is Dip Switch #2 switch 6. If you receive a test ticket for an amount like 45,000 points for a \$20.00 try switching to money mode.

For 1c Games - Cherry Master Type

Dip Switch #1

Switches #1, 5, & 7 on all else off

For games like Cherry 96, the set up is the same as for a nickel game because the board does the counting down before it is sent to the F1-Goose