



R E L I A N C E

INSTALLATION & OPERATION MANUAL



PYRAMID
TECHNOLOGIES, INC.

www.pyramidacceptors.com

Rev. K 7/28/2025

Product Overview

The Pyramid Technologies, Inc. (PTI) Reliance Thermal Printers are designed for indoor use in the Kiosk, Amusement, Gaming, Lottery and Vending markets.

Reliance Thermal Printer Features

Thermal Paper Width 58 mm to 80 mm using Adjustable Rear Guide

203 DPI Print Quality

Built-in Paper Cutter (Cutter Life Greater than 1,500,000 Cuts)

Tickets can be Printed AND cut BEFORE Presented to the Patron (This Greatly Reduces Printer jams!)

Automatic Presenting and Retraction of Tickets

Standard USB and RS-232 Interface

Flash Memory Upgradeable via USB Port

Long Life Print Head

Automatic Paper Loading

User Customizable Text and Graphics

Fonts available for most Countries

Plug and Play Operation

Real Time Clock (RTC)

Drivers available for various Operating Systems

Pyramid Welcomes Custom Applications to fit your Needs!

Product Specifications

Warranty: Longest Industry Warranty- 3 years, parts and labor (See Limited Warranty Section).

Operating Voltage	24 VDC +- 10 %
Operating Currents	Idle, 150 mA Operating, 6 A Max (2.2 Amps at 50 % Density Rate) Higher print densities may require a supply rated for 13A for 400uS
Operating Temperature	0 to 60 C, Standard Version -20 to 60 C, Low Temperature Version 85 % Maximum Non-Condensing Humidity
Print Speed	Greater than 220 MM per Second
Ejection/Retraction Speed	Greater than 1000 mm per Second
Paper Detection	Paper Low (With Arm), Paper Empty and Paper Notch Detection
Paper Weight	55 - 75 g/m2, Presenter Mode 75-90 g/m2, Continuous Mode
Print Head Life	100 Million Pulses or 150 km (93 Miles) Paper Travel Distance (12.5% max print density)
Cutter Life	Greater than 1,500,000 cuts
Net Weight	1.22 Kg (2.67 lbs)
Operating Systems	Linux (Debian, Ubuntu, Fedora, SUSE, and Mint), Mac (OSX 10.6 and newer), Windows XP, Windows Server 2003, Windows Vista, Windows Server 2008, Windows 7, Windows 8, Windows 8.1, and Windows 10 (32 and 64 bit O/S support for all drivers)
Max Paper Roll Size	7.1"/ 180 mm (utilizing paper arm optional accessory). This equates to 1345' of paper.
MAX Paper Width	3.1"/80 mm

Optional Accessories

Description	Part Number
58 mm and 80 mm Paper Arm Kit with Paper Low Sensor	95WP01
80 mm Paper Arm Kit with Paper Low Sensor	95WP02
58 mm Paper Arm Kit with Paper Low Sensor	95WP03
Serial RS-232 DB9 Harness 5 inches	05WP06
Serial RS-232 DB9 Harness 5 feet	05WP07
USB Communication Harness	05AA0049
24 VDC Power Supply Kit	05WP10
2 Wire Power Harness	05WP03
105 mm (4 1/8") Diameter Roll of Paper, 80mm wide x 450 ft	PWP02

To order any Reliance Thermal Printer, use the following order information:

Series	Description
REL-80	80 mm
REL-58	58 mm

Foreign Font Set

Please call PTI to order the Reliance with your particular country's Font Set.

What's in the Box

All Reliance thermal printers ship with the below components:

24 VDC - 2 Wire Power Harness and Power Harness Adapter	95WP05
Paper, 3 1/8 X 60' High Sensitivity Thermal CSO 1"ID Rolls Individually Flow Wrapped (clear)	PWP01
Reliance Mounting Kit	95WP04

If you have purchased the optional paper arm kit, the kit will be inside the box.

Take a Tour of the Reliance Printer

Figure 1 and 2 show you the important areas of the Reliance.

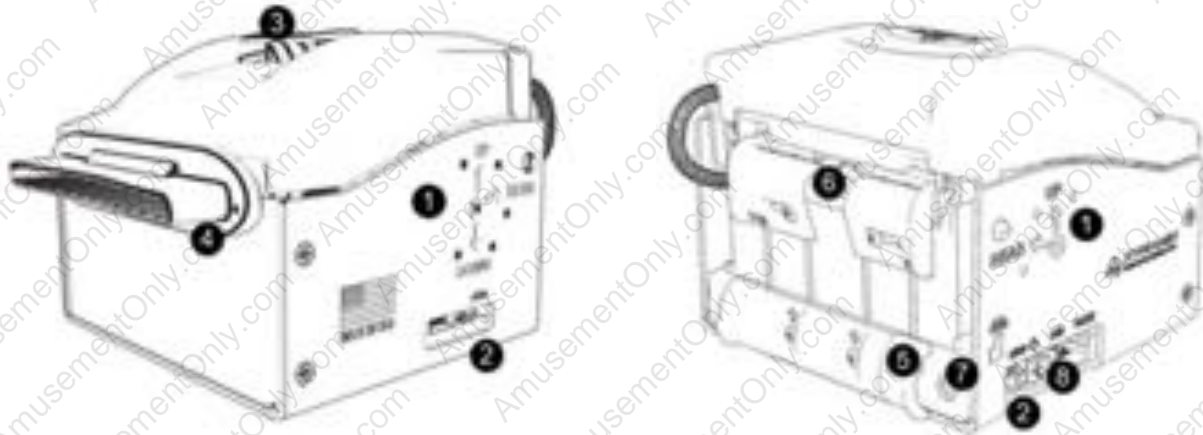

Figures 1 and 2

ID Number Description

1. Paper Arm Mounting Holes
2. Arm Sensor Plug
3. Latch to open head
4. Front Bezel
5. Paper Indicator LED
6. Adjustable Paper Guide (Set to your paper width requirements in our factory.)
7. Diagnostic Pushbutton
8. Power and Interface connections

Example Serial Number: ID **163250001**

In this example, the first two digits are the year of manufacture (2016).

The week of manufacture is week **32** of 2016.

The **5** is a placeholder for Reliance Thermal Printers

The sequential production ID number is **0001**.

Dimensional Drawings

For Dimensional Drawings, please visit our website at www.pyramidacceptors.com and look in the Reliance Thermal Printer section.

Limited Warranty

Reliance Thermal Printers are warranted for a period of Three (3) Years from date of the original invoice or 150 km (93 Miles) Paper Travel Distance or 1,500,000 paper cuts whichever comes 1st.

This warranty extends to the original purchaser of the warranted product and each transferee owner of the product, during the term of the warranty. During the warranty period, the manufacturer will repair or replace (at manufacturer's option) any parts, up to and including the complete printer, which fail to function properly because of defects in material or workmanship. This warranty does not cover any damage related to water, vandalism, chemical or liquid spills into the printer.

The manufacturer is not responsible for any consequential damage or performance degradation that results from foreign objects inserted into the printer. The product to be repaired under warranty must be delivered, inbound freight prepaid to an authorized service center. Upon request, the owner must show proof of purchase when submitting equipment for service during the warranty period. Repair or installation at the owner's location is not included in warranty. During the warranty period, manufacturer will pay all outbound ground freight charges to the owner's location. Special handling or shipping charges must be assumed by the owner. The manufacturer will not be liable for any consequential damages as a result of defects in material or workmanship. Any written or implied warranty of this product is strictly limited to the refund of the cost of goods purchased. Damage due to negligence, accidents, electrical overload, misuse, abuse, vandalism, or an act of God, is not covered by this warranty. Any alteration of the product after manufacture voids the warranty in its entirety.

Unpacking the Printer / Shipping Damage

You should always immediately unpack and inspect to see if the printer is damaged; when a product is returned to the owner after service or as a new purchase, only the consignee (the person or company receiving the printer) can file a claim against the carrier for concealed damages. Therefore you should place the printer back in its original carton along with the packing materials. Then notify the carrier of damages and request an immediate inspection of the package. Send a letter of intent to file a claim to the carrier within 72 hours from time of delivery. Please also send a copy of this letter to the shipper.

Service

For service information, please contact Pyramid Technologies, Inc. for a Service Center near you. For any items returned under warranty or for repair, complete written information including the Serial Number and model number as well as a description of the malfunction or defects must be submitted to the Service Center when requesting a Return Material Authorization number (RMA number). Owner accepts full responsibility for any return without prior

authorization. The RMA number must be displayed on the exterior of the returned product carton(s).

Installation/Mounting

The Reliance Thermal Printer has been designed to easily mount onto existing brackets in OEM equipment. If you have special mounting needs, please contact us!

Figure 3 depicts the cutout needed in order to properly mount the Reliance in your machine. Note: You must also ensure that your machine has enough internal clearance so that the roll of paper does not touch anything in the machine under normal operation.

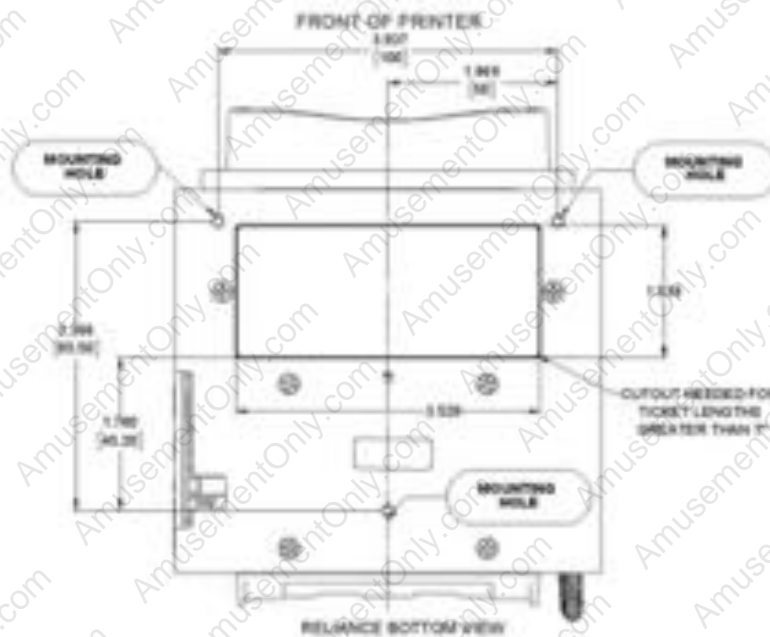

Figure 3

To install the printer, disconnect all power to the machine.

Mount the Reliance into your machine using the three screws (M4 - .7 x 8mm, Pan Head) and washers that were provided to you.

Connect the Power Cable from the host machine to the printer.

If you are utilizing the 24 VDC Reliance Power Supply Kit, now is the time to install it in your machine

Connect the interface cable (USB or RS232) from the machine to the printer.

Make sure that all wiring is properly secured in your machine.

Turn on power to your machine and follow the next step below for installing paper in the Reliance.

If you are utilizing the Reliance Paper Arm Kit, now is the time to install it on the printer. The instructions on how to attach this arm are in the shipping box. If not please visit this link for the instructions:

<https://pyramidacceptors.com/pdf/Reliance-Accessory-Arm-Installation-Guide.pdf>

Paper Arm Holder Applications

Part # 95WP03

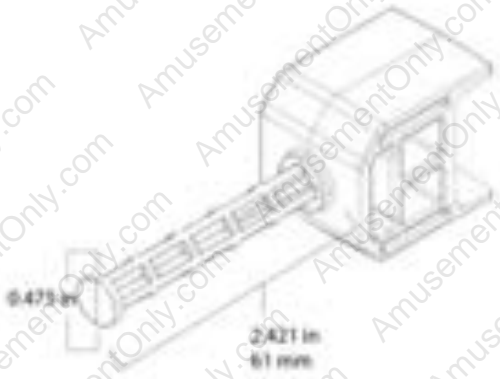

Holds Paper Size

Width: 58 mm/2.25 in

Core Size: 1/2 inch

Diameter: 7.1 in

Length: 900 ft/275 m

Part # 95WP14

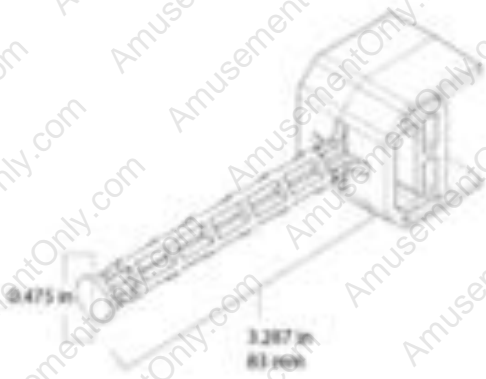

Holds Paper Size

Width: 80 mm/3 in

Core Size: 1/2 inch

Diameter: 7.1 in

Length: 900 ft/275 m

Part # 95WP02

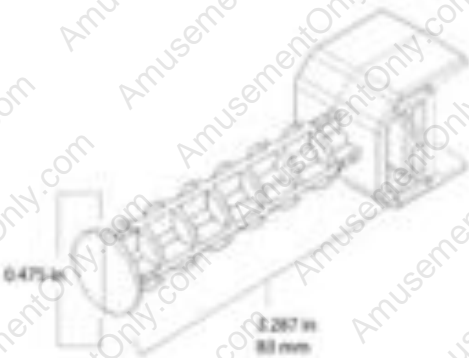

Holds Paper Size

Width: 80 mm/3 in

Core Size: 1 inch

Diameter: 7.1 in

Length: 900 ft/275 m

Installing Paper

This is the method to properly install paper in the Reliance Printer. Keep in mind that you must purchase thermal paper that is called CSO. CSO means Coated Side Out. In other words, the outside of the roll is the side that is printed on. You can tell if you have the right paper by using your fingernail and scratching the surface. If it turns gray then you have the right paper.

In addition, keep in mind that the paper must be inserted so that the side that is printed on is facing upward. If you load the paper and you don't get printed characters on it, it might be loaded in reverse. Here is how to load the paper into the Reliance:

1. Make sure the Reliance has power.
2. Before inserting paper, open the head and see that there is no paper or dust in the printer. (See Figure 4).

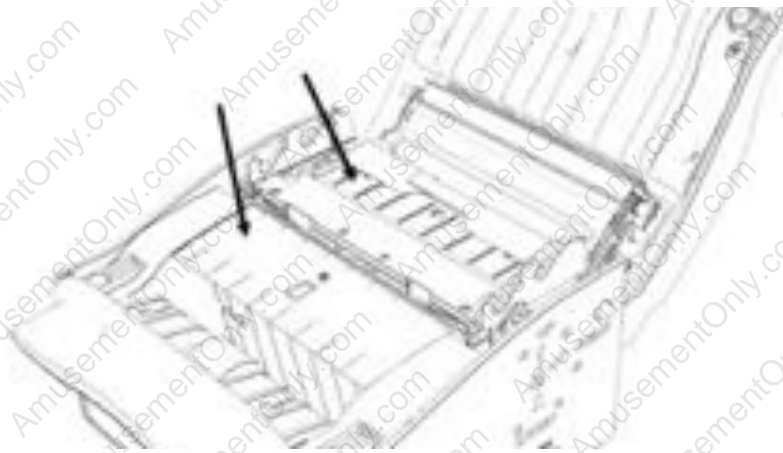

3. If there is dust or paper, refer to the maintenance and Cleaning Section on how to properly clean the Reliance.
4. Close the Head. **For proper paper insertion, the head on the Reliance must be closed.**
5. Make sure that the edge of the paper you will be inserting into the Reliance is not wrinkled and is cut straight. In addition, if starting a new paper roll, make sure you unwind the roll a few times and cut off that paper, since it could have glue on it. (See Figure 5)



6. Push the edge of the paper into the Reliance. Gently push it until the paper stops. The Reliance should start pulling this paper within 5 seconds. If not, pull the paper out, open and then close the printer and then try again.
7. Once the Reliance starts pulling the paper in, let go of the paper.
8. The Reliance will then print a long ticket and present it to you. The paper should be straight, no wrinkles and at the very end will have printed on it "Paper Loaded OK". If so, paper loading is complete.
9. If the ticket is damaged, wrinkled or does not print well, then the paper needs to be removed then reinserted. If you don't get printed characters on it. The paper might be loaded in reverse. If there is an error, start the above procedure over again. If this continues to be an issue, please see the troubleshooting chart in this manual.

Paper Restrictions

Please refrain from adding graphics within a 10mm space in the center of your paper. This will impact the printer's functionality and can lead to printing malfunctions and issues.



Printing the Software Configuration and Fonts of the Printer

If you wish to verify the current software configuration of your printer, follow these steps:

1. Remove power from the printer.
2. Push and hold the Diagnostic Push button at the back of the unit. Now, apply power while holding the Pushbutton for 5 seconds
3. The Software Configurations Settings will now print out.
4. Once the Configuration Settings has been printed, pressing the button again will print all the fonts and code pages that the printer currently has installed.
5. The printer will reset automatically in a few seconds, or you can remove power and then apply power again to return to normal operation.

Clearing a Paper Jam

Clearing a paper jam is simple with the Reliance. Referring to Figures 6 7, 8 and 9:

1. Open the head to the Reliance.

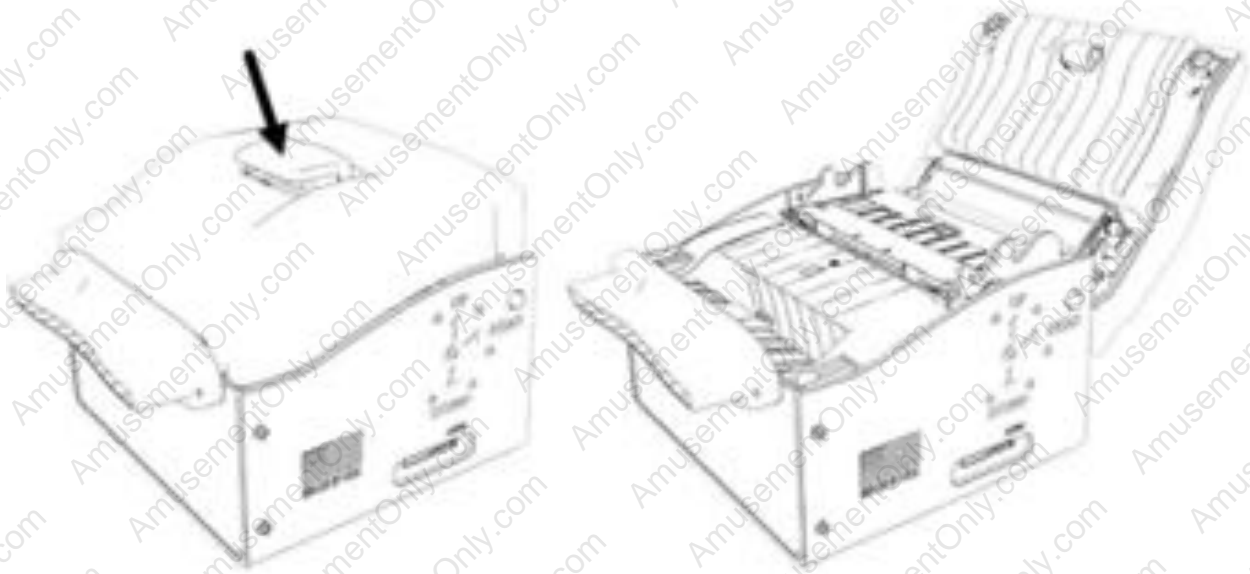

Figures 6 and 7

2. Remove any paper and examine the unit for dust. Look into the Presenter opening to ensure there is no paper stuck in there.

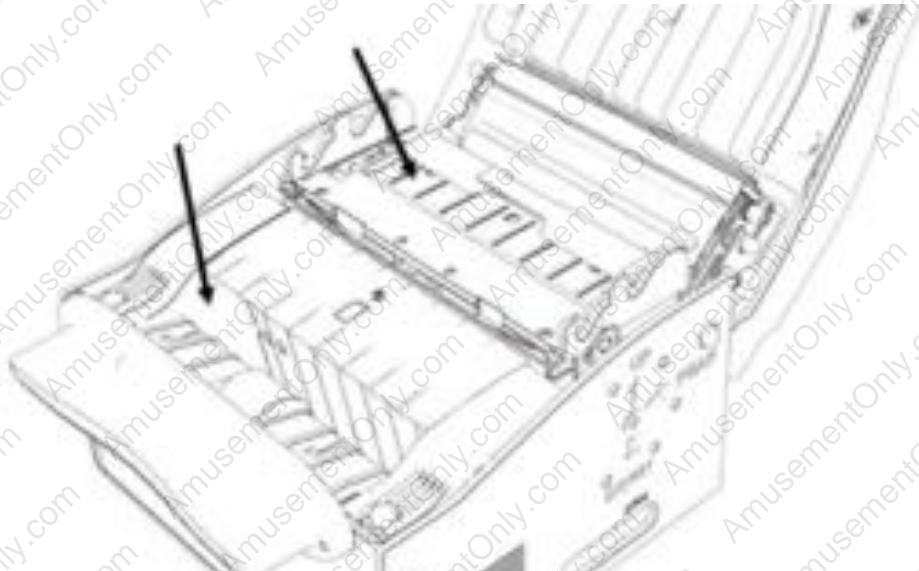

Figure 8

3. Once the paper is removed, make sure that there is no paper in the rear of the unit and that the White Paper Width Adjustment bracket is clear of any paper residue.

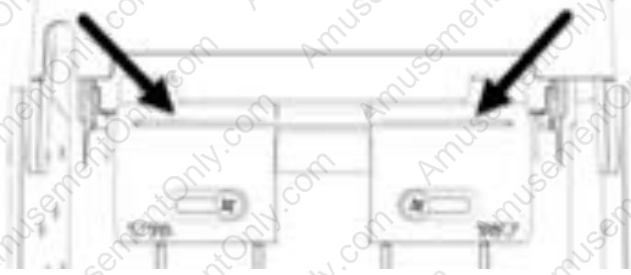

Figure 9

4. Close the lid.
5. Go back to the Installing Paper Section.

Adjusting the Rear Guide

The Reliance printer is shipped to you already set up for the paper width you ordered. If you need to change this paper width, loosen the screws indicated in the figure below and push the guides together to the desired width.

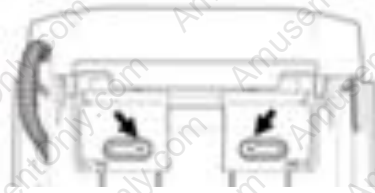

Figure 10

For 70mm paper, align the arrows on the paper guides to the raised ribs on the printer frame as shown, tighten screws:

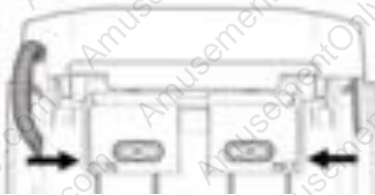

Figure 11

For 58 mm paper, push the paper guides together completely as shown, tighten screws:

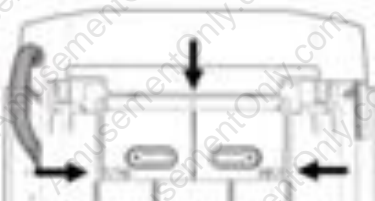

Figure 12

For 80 mm paper, push the paper guides apart as shown below, tighten screws:

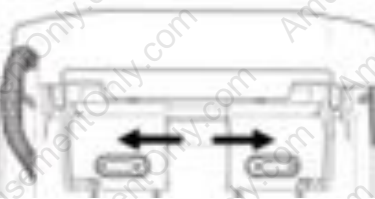

Figure 13

Maintenance and Cleaning

The Reliance Series Thermal Printer is relatively maintenance free. An occasional cleaning is all that is needed to keep the printer in top operation. Refer to Figure 7 and this information. To clean the printer.

First, open the Reliance using the top latch.

Look in the Reliance and remove any paper or paper pieces that are in the unit. In particular, look at the white guide near the rear of the unit as well as the large rectangular opening near the front of the Reliance.

Clean the printer head and rubber rollers (Front and rear rollers) using a can of compressed air (commonly sold at office supply stores.) See Figure 14.

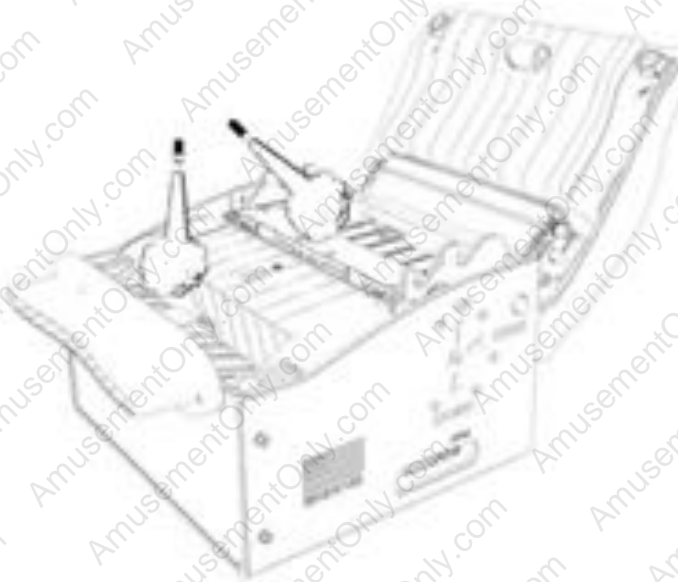

Figure 14

Clean the front slot of the printer in the same manner as above. For detailed cleaning, a simple Q-tip works best.

Close the printer.

Note: Do not use any oils or silicone spray on the Reliance!

Reliance Setup Using a PC

This method allows you to change the configuration of the Reliance printer easily. This program is free of charge to our customers. A USB harness is all that is required to configure the printer (PTI Part Number- 05AA0049).

<https://pyramidacceptors.com/app/reliance-tools>

Once configured, the printer will remember these settings, even if power is removed.

Flash Programming

Downloading new software to the Reliance Thermal Printer is accomplished using a PC. This free application and the latest firmware can be downloaded from the Pyramid website:

<https://pyramidacceptors.com/app/reliance-tools>

To change the printer's software, you will use a USB harness that has type A/B connectors and is commonly called a "USB printer cable" (PTI Part Number- 05AA0049). This, and a powered up printer is all that is required to download new software to the printer.

Pushbutton Operation

The Pushbutton on the Reliance Thermal Printer is utilized for various functions and can be used to do the following:

1. Print a test ticket and feed paper through the printer
2. Print the configuration and status of the printer
3. Print the supported fonts

Print a Test Ticket

Press the button at any time when the printer is powered on.

Pressing once will print a test ticket.

Press and hold to continue to print and move paper until the button is released.

Print Configuration Ticket

Press and hold the button, then apply power to the printer. The printer's configuration will be printed. (See "Printing the Software Configuration and Fonts of the Printer" section.)

Print Supported Fonts

After the configuration ticket described above is printed, pressing the button again will print the supported fonts. (See "Printing the Software Configuration and Fonts of the Printer" section.)

Diagnostic Features

The Reliance Printer must have power to show diagnostics. The multi-color LED at the rear of the unit will flash a certain amount of times should there be an issue. This flash code corresponds to the errors listed below. If the LED is solid green then the printer is functioning properly and is ready to go.

Reliance LED Flash Codes

The flash codes shown correspond to a Reliance printer error. The acceptor will flash the error code, then wait a second and flash it again. This LED is located at the rear of the printer.

Flashing Code	Meaning	Corrective Action
Off		
LED always OFF	The printer has no power	Check that power has been applied
Green		
LED always ON	Printer is OK	None
1 Flash	Paper Low	The paper arm sensor detects that the paper is low. Consider installing a new paper roll soon.
Blue		
LED always ON	Printer is overheating.	Let the printer sit until a valid operating temperature is reached.
1 Flash	Head Open	The "Platen" (front portion of the head) is not locked properly. Refer to the Paper Jam Clearing procedure to ensure the Platen is closed.
2 Flashes	Paper Out	The printer has run out of paper. Replace the roll.
3 Flashes	Printer Supply Voltage Error	Check the power supply for proper operating voltage.
Red		
LED always ON	Paper or Print Head jam.	The printer is jammed. Refer to Paper Jam Clearing procedure.
1 Flash	Cutter Error	Open the printer and remove all paper. Then close the printer.
2 Flashes	Memory Error	Call PTI Technical Support.
3 Flashes	Presenter Error	Call PTI Technical Support.
4 Flashes	Unknown Error	An error has occurred with an unknown source or issue call PTI Technical Support.

Reliance Bezel LED Flash Codes

If the Reliance printer is not printing and/or is unresponsive to print commands and the Bezel LEDs are flashing, attention is required.

Flash Code	Meaning	Corrective Action
Solid On	Printer is Ok	None
Flashing ON ½ Second OFF ½ Second	Printer is in update mode.	Remove and reapply power to the printer. Connect the printer to Reliance Printer Tools PC software and update the firmware on the printer. Call Pyramid PTI Technical Support if needed.
Very rapid flashing	Printer is in recovery mode.	Remove and reapply power to the printer. Connect the printer to Reliance Printer Tools PC software and update the firmware on the printer. Call PTI for Technical Support if needed.

Need Assistance?

Call +1 480-507-0088

7:00 AM to 2:30 PM USA Pacific Time

support@pyramidacceptors.com

We are here to Help!



R E L I A N C E

