

# STABILITY

in a sea of uncertainty



## PHOENIX THERMAL PRINTER™

Simplicity of design. Features that matter. Reliability that you can trust.

Phoenix Thermal Printer incorporates these aspects to bring you a product that truly makes a difference in today's marketplace. All this along with the developer friendly environment that Pyramid is known for and you have a true winner. Make the easy decision today and enjoy all the benefits that Phoenix has to offer. Quality, Confidence, Value; the Phoenix Thermal Printer is your thermal printer of choice.



# PHOENIX THERMAL PRINTER™

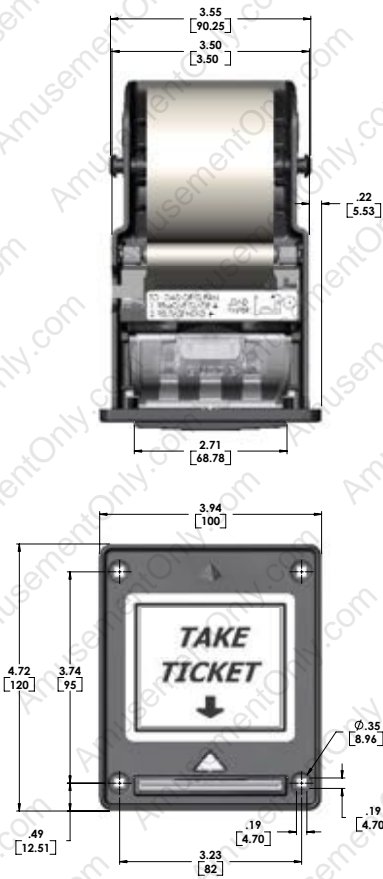

## Model Numbers

PHX-Pulse - Pulse Interface

PHX-POG - Pulse/Pot-O-Gold Interface

PHX-USB - USB Interface

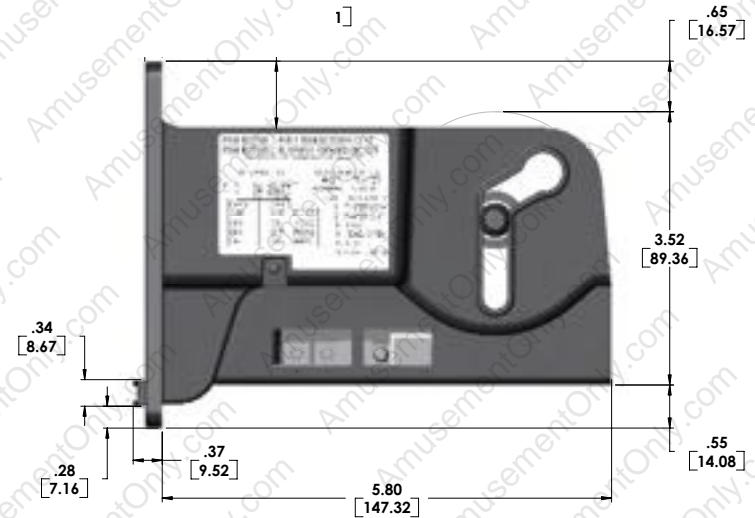

## Under the Hood

- Automated loading of 58mm thermal paper
- Built-in paper cutter for full and partial cuts USB, Pot-O-Gold, and Pulse Interfaces
- Easily convert coin hopper games to ticket printing  
Time/date stamp printed on tickets
- Standard panel mounting
- Simple DIP switch configuration & easy flash updates
- User-customizable text and graphics for coupons and tickets
- PTI welcomes custom applications to suit your printing needs.

## Specifications

Operating Voltage:  
12 VDC +/- 10%

Operating Current:  
Idle = 15mA,

Operating = 5A (Max)

Operating Temperature:  
0 to 60° C, 85% non-condensing humidity (Max)

Print Speed:  
Approx. 1 coupon or ticket in three (3) seconds.

Paper Detection:  
Signals Paper Low and Paper Empty conditions.

Net Weight: 1.25 lbs.

## Accessories

Power Harness: Part Number 5P000

Pot-O-Gold Communication Harness: Part Number 5P001

Serial RS232 (DB9) Harness: Part Number 5P002

USB Communication Harness: Part Number 05AA0049

Security Mounting

Plate Kit: Part Number 95P02