



Bill Acceptor  
**V7P**

Installation Guide



## **Use of Materials Limitations**

International Currency Technologies Corporation (ICT) all rights reserved.

All materials contained are the copyrighted property of ICT.

All trademarks, service marks, and trade names are proprietary to ICT.

ICT reserves the right at all times to disclose or to modify any information as ICT deems necessary to satisfy any applicable law, regulation, legal process or governmental request, or to edit, refuse to post or to remove any information or materials, in whole or in part, in ICT's sole discretion.

## Contents

1. Introduction	
1-1. Overview .....	2
1-2. Features .....	2
2. Specifications .....	2
3. Packing List .....	3
4. Dimension .....	4
5. Installation	
5-1. Harness Application .....	4
5-1-1. I/O Circuit .....	10
5-2. DIP Switch Setting .....	13
5-3. Firmware Download and Upgrade	
5-3-1. USB Pen Drive Firmware Upgrade .....	13
5-3-2. USB Cable Firmware Upgrade .....	14
6. Maintenance .....	15
7. Troubleshooting	
7-1. Bezel LED Errors .....	16
7-2. Back LED Errors .....	17
7-3. USB Firmware Upgrade LED Errors .....	17

# 1. Introduction

## 1-1. Overview

V7P is a bill acceptor which features not only high-security module with bill box but also outstanding recognition, acceptance rate up to 96% or even greater. The built-in USB port allows convenient firmware upgrades via USB flash drive.

## 1-2. Features

- Four way bill insertion acceptance.
- Numerous interfaces available.
- High Acceptance Rate up to 96%.
- Auto-calibrating.

# 2. Specifications

## **General**

**Acceptance Rate** 96% or greater

*Note: The incomplete bills such as extremely dirty, wet, broken or wrinkled ones are excluded.*

**Bill Insertion** Four-way acceptance

**Transaction Speed** Approx. 3 seconds to stack

**Interface** Pulse, RS232, MDB

## **Electrical**

**Power Consumption** Standby: 0.3A  
Operation: 1A  
Maximum: 2A

**Power Source**

DC 12V±10%  
DC 24V±10%  
DC 24V/34V±10%  
AC 24V±10%

**Operation Environment**

Operation Temperature: -10°C~55°C  
Storage Temperature: -30°C~70°C  
Humidity: 30%~95%RH  
(no condensation)

**Mechanical****Outline Dimension**

Refer to Page.4

**Bill Width**

Bezel(71mm): 62~70 mm  
Bezel(73mm): 62~72 mm

**Bill Capacity**

Approx. 300 bills  
Approx. 600 bills

**Weight**

With 300 bills Stacker: Approx.1.06kg  
With 600 bills Stacker: Approx.1.30kg

**Installation**

Indoor

### **3. Packing List**

**Main**

Bill Acceptor

**Accessory**

Harnesses: see 5-1  
V7P Installation Guide  
V7P DIP Switch Setting Guide

## 4. Dimension

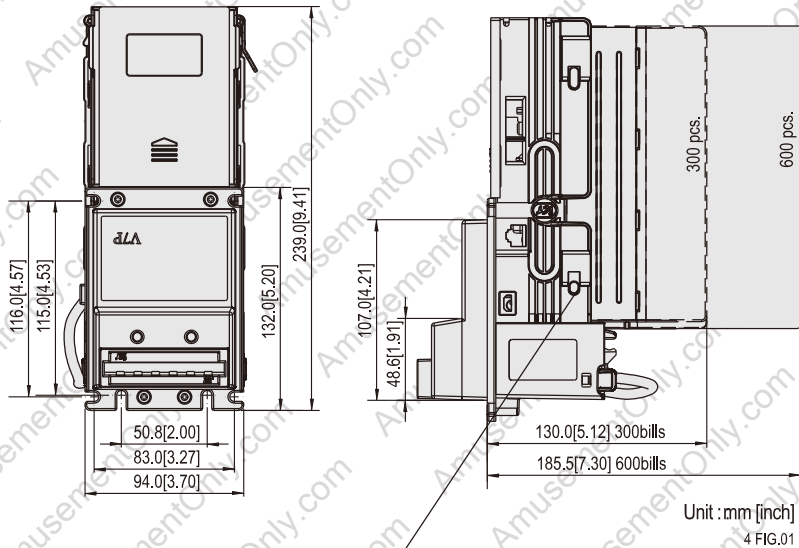

## 5. Installation

### 5-1. Harness Application

5-1 TABLE 01

Interface	Used Voltage	Usage	Harness	Page
Pulse	12V DC	Power & *Data Comm.	WEL-RV701	5
		Extension Wire	CU-R961-1	5
	24V AC	Power & *Data Comm.	WEL-RV703	6
		Extension Wire	WEL-RV702	6
MDB	24V/34V DC	Power & *Data Comm.	WEL-RM006	7
ICT Protocol (RS232)	12V DC	Power	WEL-RV701	5
		Extension Wire	CU-R961-1	5
		*Data Comm.	WEL-RV706-1 or 2-BA-RV706	8
USB Download	-	USB Extension Wire	WEL-RX7P02-1	9

\*Data Comm. : Data Communication.

5-1 FIG.01

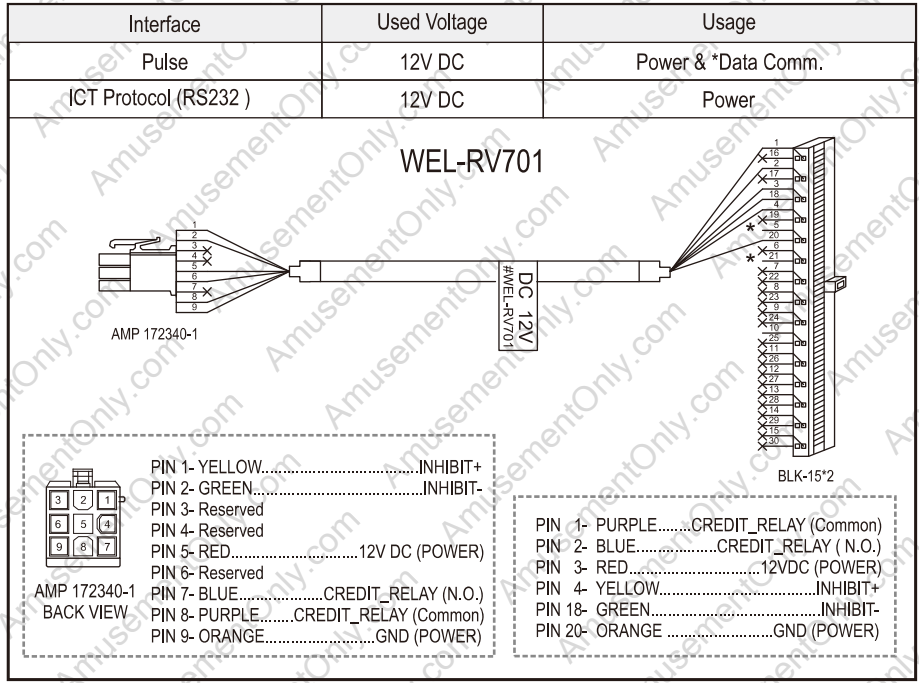

5-1 FIG.02

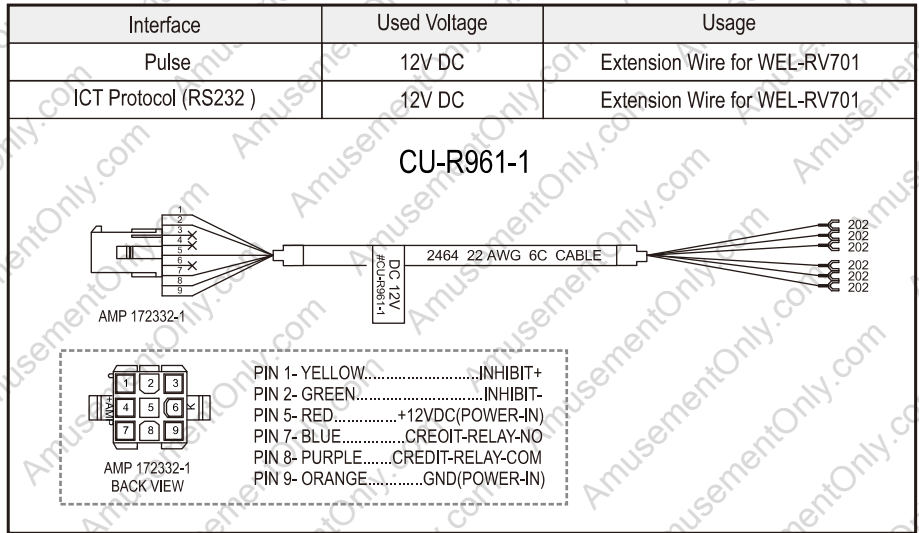

5-1 FIG.03

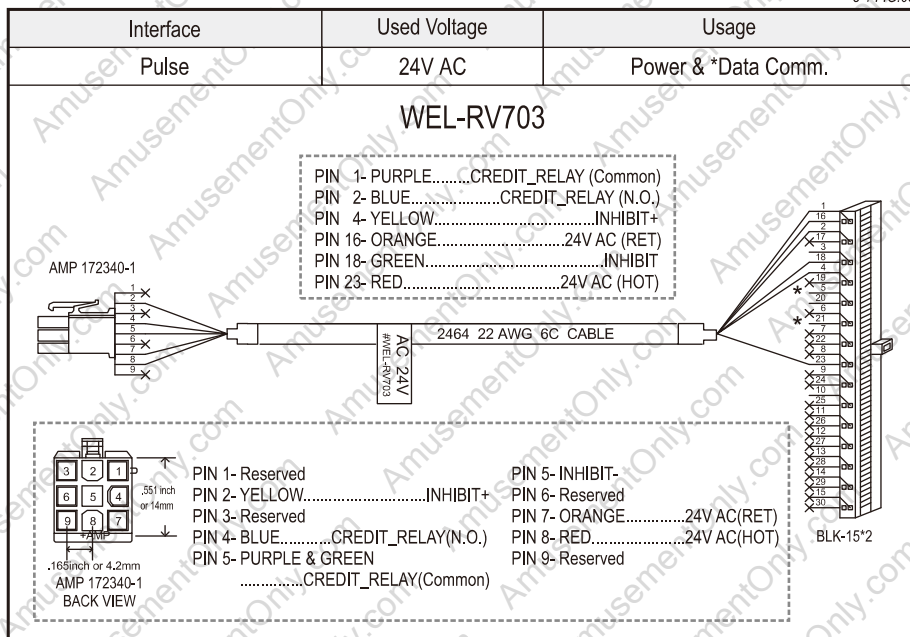

5-1 FIG.04

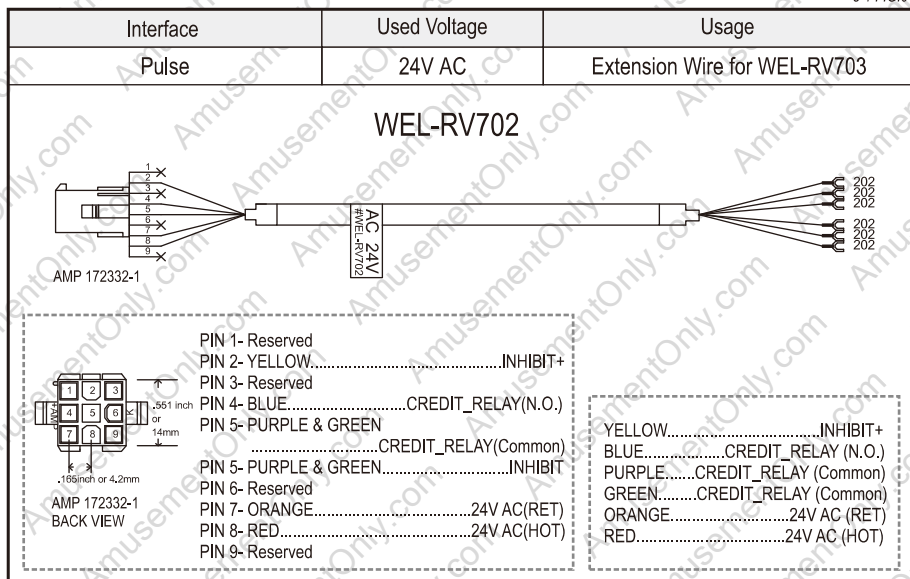

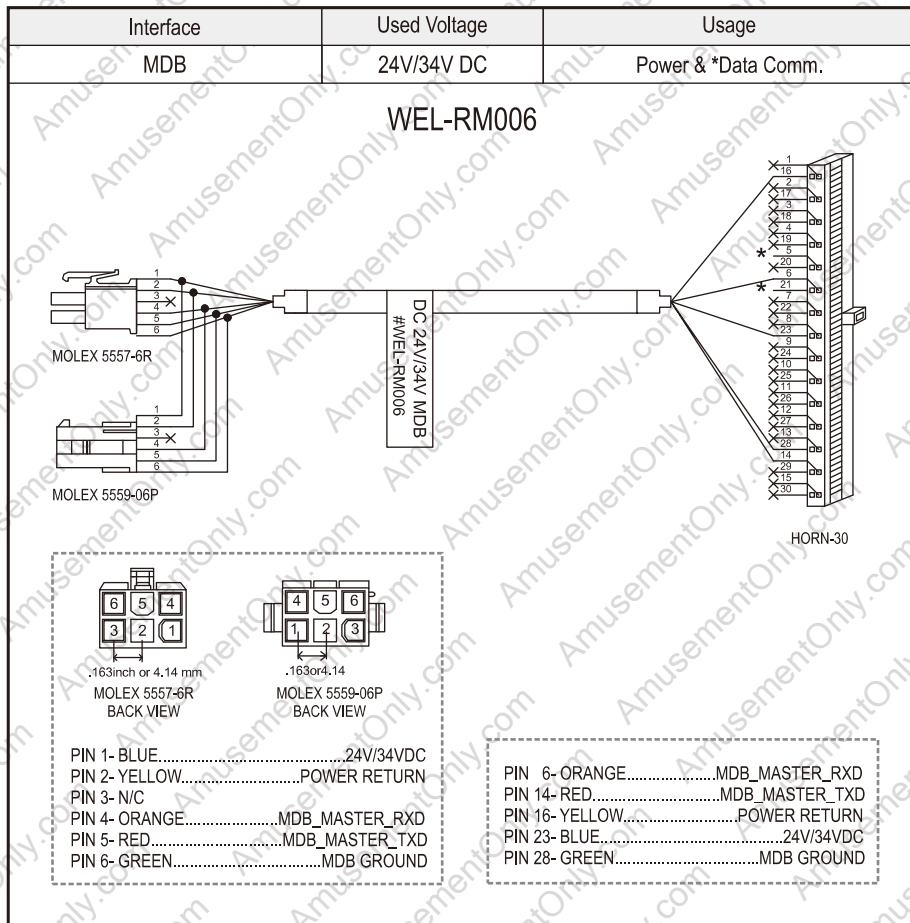

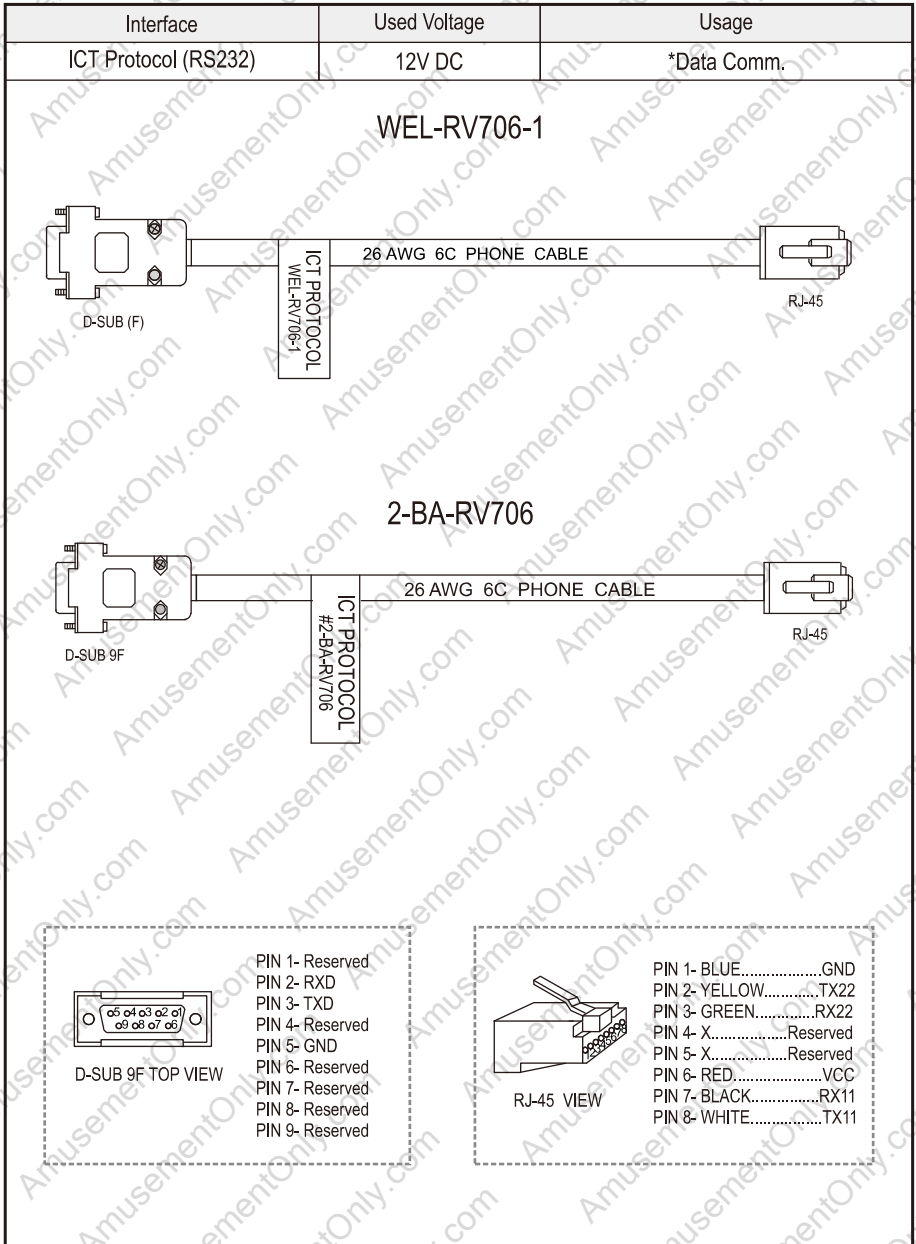

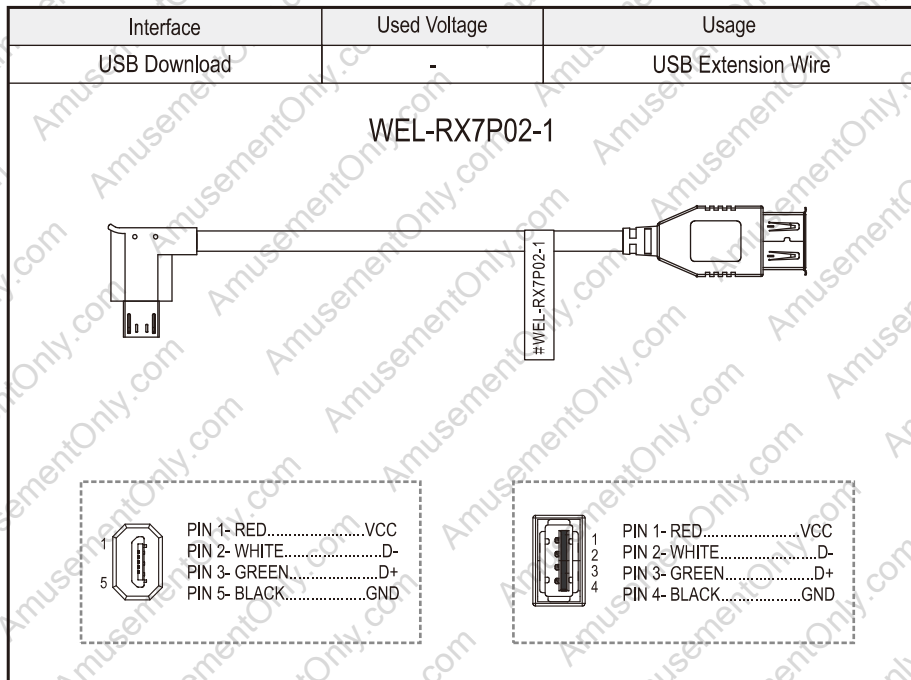

### 5-1-1. I/O Circuit

#### Pulse Interface

5-1-1 FIG. 01

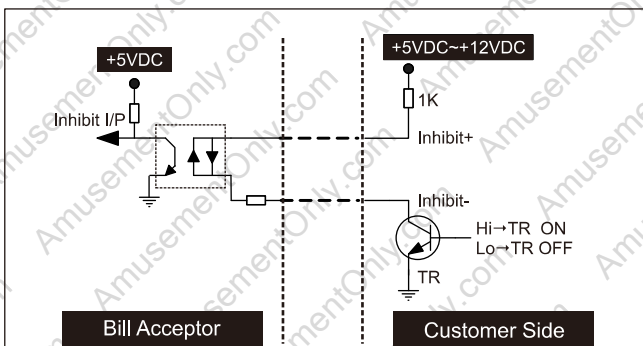
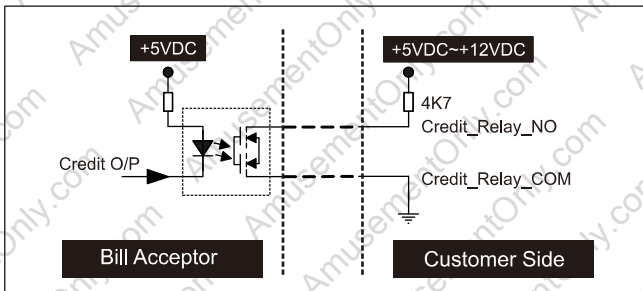

BA Status	DIP SW Setting	Control Signal
Inhibit	Inhibit Active	Low
		High
Enable	Inhibit Active	Low
		High

ICT-Protocol Interface

5-1-1 FIG. 02

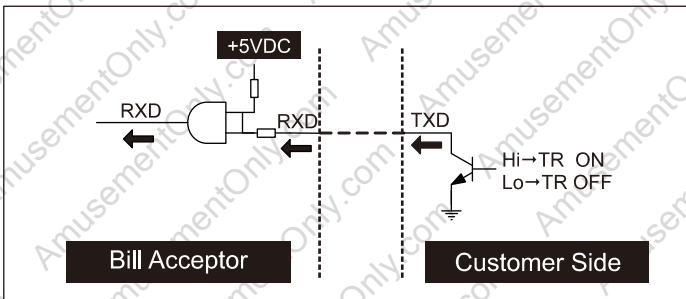
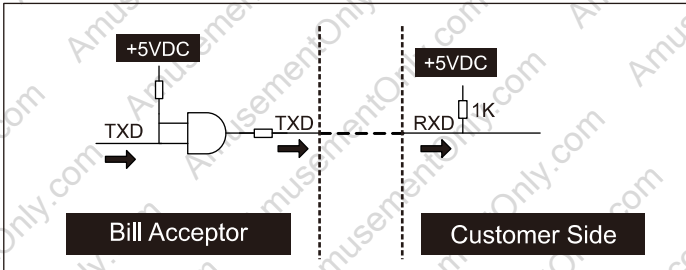

MDB Interface

5-1-1 FIG. 03

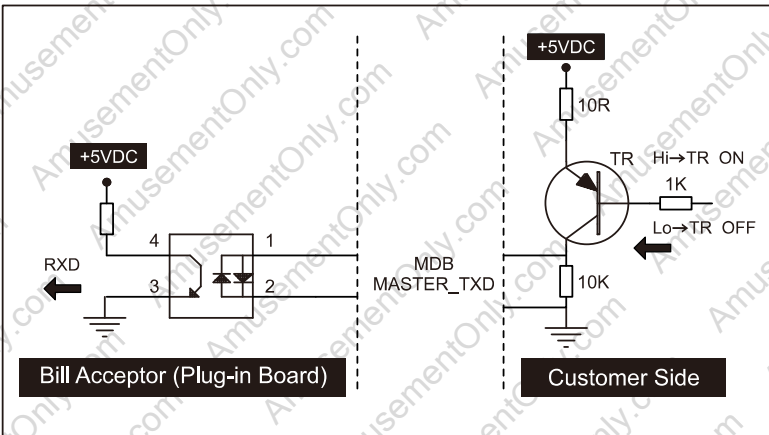
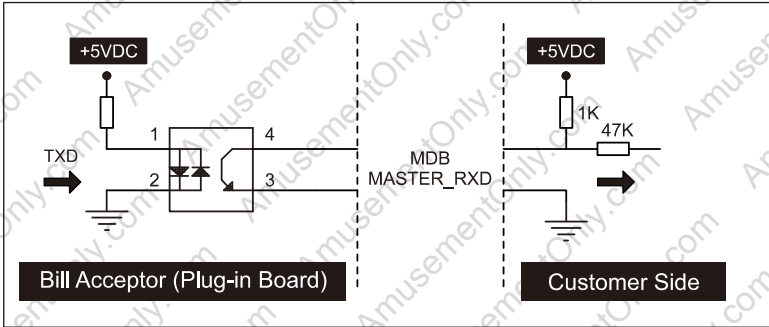

## 5-2. DIP Switch Setting

There are two serial DIP switches which are located on the side of V7P Series (as FIG.01). According to different currencies which are used by users, DIP switch settings could be varied to fit users' need. Besides, there's also a serial DIP switches on CPU board inside of V7P Series for interface settings.(as FIG.02). Please refer to "V7P Series DIP Switch Setting" Guide in the package for more detail.

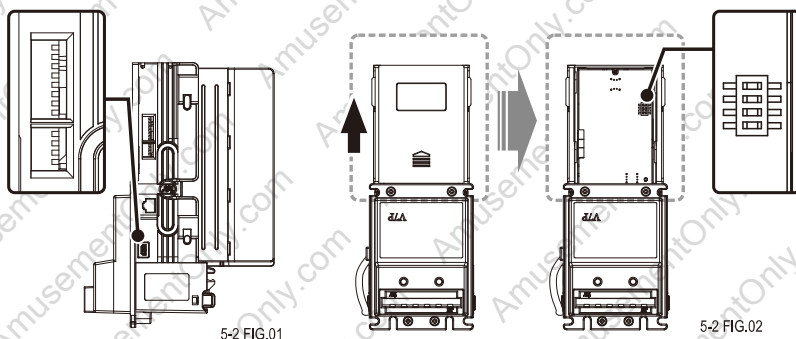

## 5-3. Firmware Download and Upgrade

### 5-3-1. USB Pen Drive Firmware Upgrade

Step 1.

Put the "V7Pxxxxxx.bin" file into your USB Flash Disk.



## Step 2.

Turn off V7P, plug the USB Flash Disk into the USB connector on the V7P with USB extension cable and then turn on the V7P.

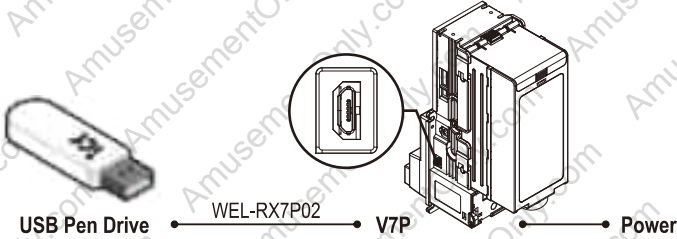

## Step 3.

The LED in the front side of bezel will flash twice, then remove the USB Flash Disk from V7P.

## Step 4.

Wait for about 30sec., then V7P will automatically reset and standby for normal operation.

## 5-3-2. USB Cable Firmware Upgrade

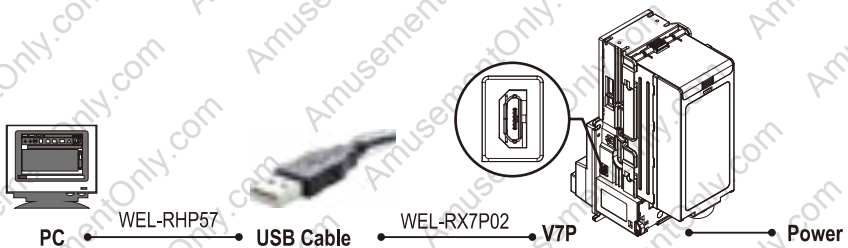

## 6. Maintenance

To make sure the bill acceptor always works smoothly, please clean the internal parts regularly.

To clean the internal parts:

1. Press the buttons on the sides of bill path unit and pull the unit out.
2. Use a soft, dry cloth or towel to clean the bill path and sensors.

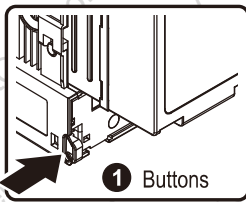

6 FIG.01-1

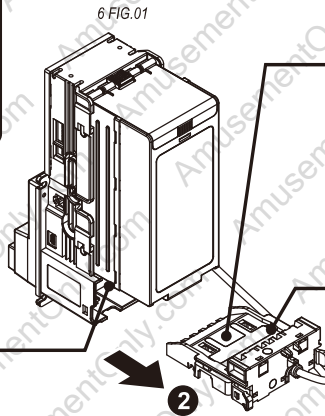

6 FIG.01

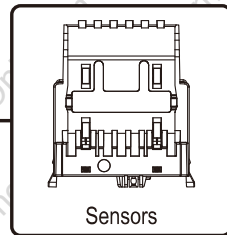

6 FIG.01-3

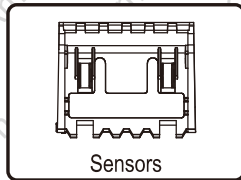

6 FIG.01-2

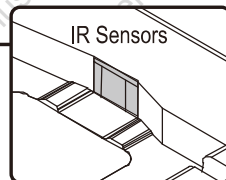

6 FIG.01-4

<b>Maintenance Notice</b> (Any improper maintenance will invalidate the warranty.)	
	<b>Recommended</b> Mild, non-abrasive, soap water.
<b>DO NOT USE</b>	Organic solvent , Alcohol, Volatile liquid.

## 7. Troubleshooting

### 7-1. Bezel LED Errors

7-1 TABLE 01

LED	Status	Correct Actions
<b>GREEN</b>	White Card Calibration.	Please calibrate with ICT white calibration card.

7-1 TABLE 02

LED Flashes		Status	Correct Actions
RED	GREEN		
1		Bill jammed.	Remove the bill box by sliding the top button and the bill path(as 7-1 FIG.02), and then remove the jammed bill.
2		Disable.	Inspect the right DIP switch setting.
3		Recognition sensor module error.	Inspect the foreign objects on sensor or bill path and clean.
3	1	Optical anti fishing sensor module error.	Inspect the foreign objects on security hook and clean.
3+2		Hook sensor error.	
4		Anti - string sensor error or a stringing attempt has detected.	Inspect the foreign objects on sensor or bill path and clean.
5		Bill box has been removed.	Replace the bill box.
6		Stacker error or stacker full.	Empty the bill box.
7		Motor error.	Inspect the foreign objects on bill path and clean.

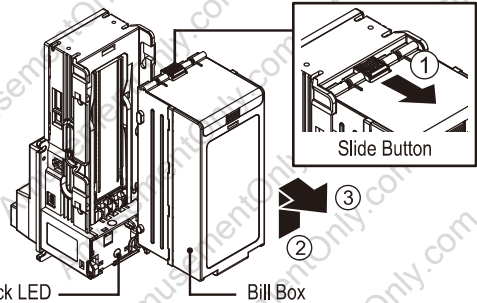
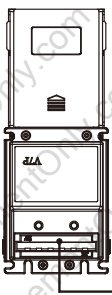

**!** If the error can not be solved after corrective actions or happen again, please contact ICT for technical support.

## 7-2. Back LED Errors

7-2 TABLE 01

LED Flashes	Status	Correct Actions
RED		
1	Bill jammed.	Remove the bill box by sliding the top button and the bill path(as 7-1 FIG.02), and then remove the jammed bill.
2	Disable.	Inspect the right DIP switch setting.
3	Recognition sensor module error.	Inspect the foreign objects on sensor or bill path and clean.
3+1	Optical anti fishing sensor module error.	Inspect the foreign objects on security hook and clean.
3+2	Hook sensor error.	
4	Anti - string sensor error or a stringing attempt has detected.	Inspect the foreign objects on sensor or bill path and clean.
5	Bill box has been removed.	Replace the bill box.
6	Stacker error or stacker full.	Empty the bill box.
7	Motor error.	Inspect the foreign objects on bill path and clean.

## 7-3. USB Firmware Upgrade LED Errors

7-3 TABLE 01

LED Flashes	Status	Correct Actions
RED		
1	USB Firmware Upgrade Errors.	<ol style="list-style-type: none"> <li>1. Make sure the USB if you can be normal to read.</li> <li>2. Make sure USB in the program are correct.</li> </ol>



**If the error can not be solved after corrective actions or happen again, please contact ICT for technical support.**



**ict** Taiwan

**International Currency Technologies Corporation**

No.28, Ln. 15, Sec. 6, Minquan E. Rd., Neihu Dist., Taipei City 114, Taiwan

[sales@ictgroup.com.tw](mailto:sales@ictgroup.com.tw) (For Sales)

[fae@ictgroup.com.tw](mailto:fae@ictgroup.com.tw) (For Customer Service)

Website: [www.ictgroup.com.tw](http://www.ictgroup.com.tw)

