



A7/V7 *Series*

Bill Acceptor **Installation Guide**

International Currency Technologies Corp.

Use of Materials Limitations

International Currency Technologies Corporation (ICT) all rights reserved.

All materials contained are the copyrighted property of ICT.

All trademarks, service marks, and trade names are proprietary to ICT.

ICT reserves the right at all times to disclose or to modify any information as ICT deems necessary to satisfy any applicable law, regulation, legal process or governmental request, or to edit, refuse to post or to remove any information or materials, in whole or in part, in ICT's sole discretion.

Contents

1. Introduction	
1-1. Overview	2
1-2. Features	2
2. Specifications	2
3. Packing List	4
4. Dimension	5
5. Installation	
5-1. Harness Application	6
5-1-1. I/O Circuit	19
5-2. DIP Switch Setting	25
5-3. Software Download and Upgrade	25
6. Maintenance	26
7. Troubleshooting	
7-1. Back LED Errors.....	27

1. Introduction

1-1. Overview

A7/V7 Series is a bill acceptor which features not only high-security module with bill box but also outstanding recognition, acceptance rate up to 96% or even greater.

1-2. Features

- Four way bill insertion acceptance.
- Numerous interfaces available.
- Easily Install & Maintain.
- High Acceptance Rate up to 96%.
- Auto-calibrating.

2. Specifications

General

Acceptance Rate 96% or greater

Note: The incomplete bills such as extremely dirty, wet, broken or wrinkled ones are excluded.

Bill Insertion Four-way acceptance

Transaction Speed Approx. 3 seconds to stack

Interface Standard Pulse, 5V Enable, MDB, ICT Protocol, Parallel A3

Electrical

Power Consumption	A7- 12V DC	Standby : 0.3A, 4W Operation: 0.9A, 11W Maximum: 2.6A, 32W
	117V AC	Standby : 0.06A, 7W Operation: 0.12A, 15W Maximum: 0.4A, 47W
	V7- 12V DC	Standby : 0.3A, 4W Operation: 0.8A, 10W Maximum: 2.5A, 30W
	24V AC	Standby : 0.2A, 5W Operation: 0.5A, 12W Maximum: 1.5A, 36W
	24V/34V DC	Standby : 0.15A, 6W Operation: 0.4A, 14W Maximum: 1.35A, 46W

Power Source	A7- 12V DC(11.4~12.6V DC) 117V AC(105.3~128.7V AC)
	V7- 12V DC(11.4~12.6V DC) 24V AC(21.6~26.4V AC) 24V/34V DC(20V~42.5V DC)

Operation Environment	Operation Temperature: 0°C~55°C Storage Temperature: -30°C~70°C Humidity: 30%~85RH (no condensation)
-----------------------	--

Mechanical

Outline Dimension	Refer to Page.5
Bill Width	62~72 mm

A7 / V7 Bill Acceptor

Bill Capacity

Approx. 100 bills (80~120)
200 bills (200~300)
400 bills (350~450)
800 bills (750~850)

Weight

Approx. 1.25kg

Installation

Indoor

3. Packing List

Main

Bill Acceptor

Accessory

Harnesses: see 5-1
A7/V7 Installation Guide
A7/V7 DIP Switch Setting Guide

4. Dimension

Horizontal

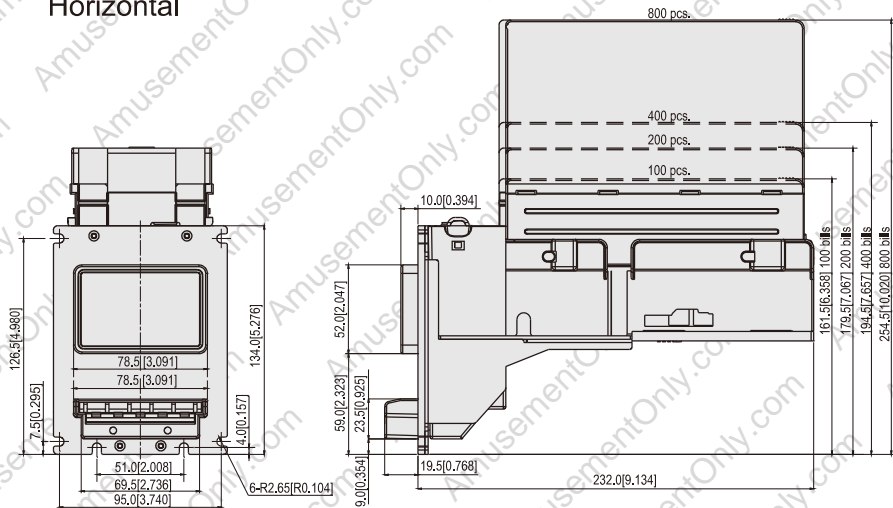

Unit : mm [inch]

4 FIG.01

Vertical

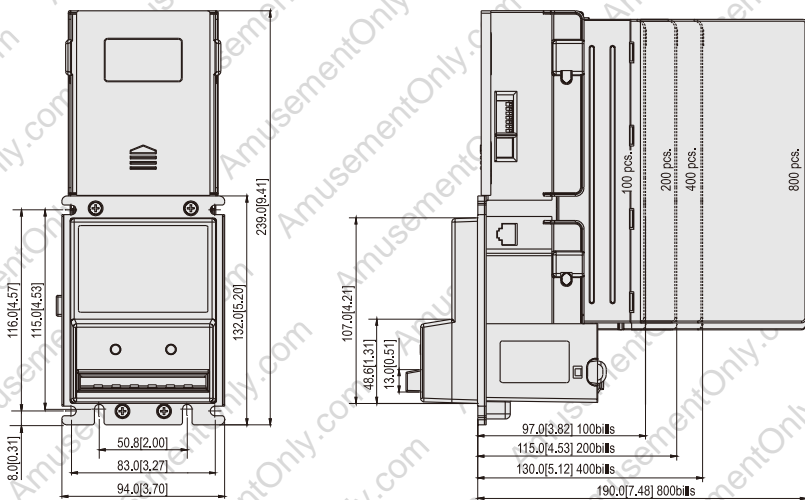

Unit : mm [inch]

4 FIG.02

5. Installation

5-1. Harness Application

5-1 TABLE 01

Model	Interface	Used Voltage	Usage	Harness	Page
A7	Standard Pulse	117V AC	Power & *Data Comm.	WEL-RM008	7
			Extension Wire	WEL-RM012	8
		12V DC	Power & *Data Comm.	WEL-RM007	9
			Extension Wire	CU-R961-1	10
	5V Enable	117V AC	Power & *Data Comm.	WEL-RM017	11
			Extension Wire	WEL-RM018	12
	ICT Protocol (RS232)	12V DC	Power	WEL-RM007	9
			**Power Ext.	CU-R961-1	10
			*Data Comm.	WEL-RV706-1 or 2-BA-RV706	13
		117V AC	Power	WEL-RM008	7
			**Power Ext.	WEL-RM012	8
			*Data Comm.	WEL-RV706-1 or 2-BA-RV706	13
	V7	Standard Pulse	12V DC	Power & *Data Comm.	WEL-RV701
Extension Wire				CU-R961-1	10
24V AC			Power & *Data Comm.	WEL-RV703	16
			Extension Wire	WEL-RV702	15
MDB		24V/34V DC	Power & *Data Comm.	WEL-RM006	17
ICT Protocol (RS232)		12V DC	Power	WEL-RV701	14
			Extension Wire	CU-R961-1	10
			*Data Comm.	WEL-RV706-1 or 2-BA-RV706	13
			Parallel A3	24V AC	Power & *Data Comm.

*Data Comm. : Data Communication.

**Power Ext. : Power Extension Wire

***5RBG-AA203L1-xx : Plug-in Box & Cables, "xx" varies from version to version.

Interface	Used Voltage	Usage
STD Pulse	117V AC	Power & *Data Comm.
ICT Protocol (RS232)	117V AC	Power

WEL-RM008

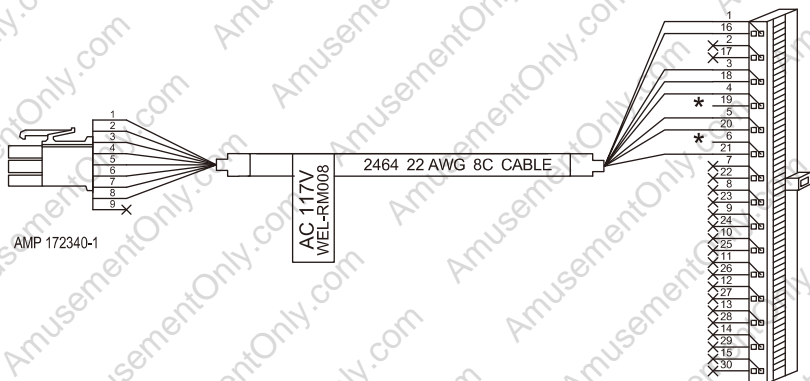

AMP 172340-1 BACK VIEW

3	2	1
6	5	4
9	8	7

AMP

- PIN 1- YELLOW.....NEUTRAL INHIBIT
- PIN 2- RED.....NEUTRAL ENABLE
- PIN 3- BROWN.....HOT ENABLE
- PIN 4- BLACK.....117VAC HOT(Power)
- PIN 5- GREEN.....Earth-Ground
- PIN 6- WHITE.....117VAC NEUTRAL(Power)
- PIN 7- BLUE.....CREDIT_RELAY(N.O.)
- PIN 8- PURPLE.....CREDIT_RELAY(Common)

- PIN 1- PURPLE.....CREDIT_RELAY(Common)
- PIN 3- RED.....NEUTRAL ENABLE
- PIN 4- WHITE.....117VAC NEUTRAL(Power)
- PIN 5- YELLOW.....NEUTRAL INHIBIT
- PIN 16- BLUE.....CREDIT_RELAY(N.O.)
- PIN 18- BROWN.....HOT ENABLE
- PIN 20- BLACK.....117VAC HOT (Power)
- PIN 21- GREEN.....EARTH GROUND

Interface	Used Voltage	Usage
STD Pulse	117V AC	Extension Wire for WEL-RM008
ICT Protocol (RS232)	117V AC	Extension Wire for WEL-RM008

WEL-RM012

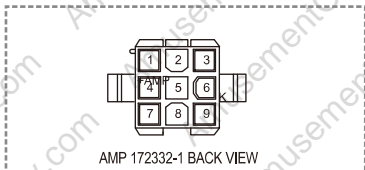
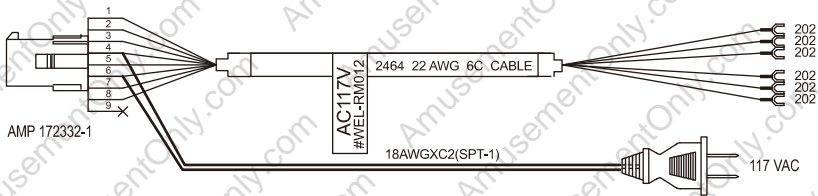

- PIN 1- YELLOW.....NEUTRAL INHIBIT
- PIN 2- RED.....NEUTRAL ENABLE
- PIN 3- ORANGE.....HOT ENABLE
- PIN 4- BLACK.....17VAC HOT (Power)
- PIN 5- GREEN.....Earth - Ground
- PIN 6- BLACK.....117VAC NEUTRAL (Power)
- PIN 7- BLUE.....CREDIT_RELAY (N.O.)
- PIN 8- PURPLE.....CREDIT_RELAY (Common)
- PIN 9- Reserved

- YELLOW.....NEUARAL INHIBIT
- RED.....NEUTRAL ENABLE
- ORANGE.....HOT ENABLE
- GREEN.....Earth - Ground
- BLUE.....CREDIT_RELAY (N.O.)
- PURPLE.....CREDIT_RELAY (Common)



Interface	Used Voltage	Usage
STD Pulse	12V DC	Power & *Data Comm.
ICT Protocol (RS232)	12V DC	Power

WEL-RM007

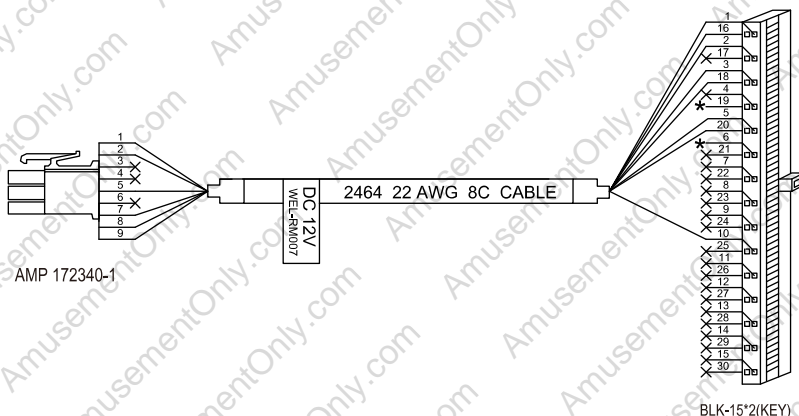

PIN 1- YELLOW.....	INHIBIT+
PIN 2- GREEN.....	INHIBIT-
PIN 3- RESERVED	
PIN 4- RESERVED	
PIN 5- RED.....	12V DC (POWER)
PIN 5 DOTTED- BLACK.....	12V DC (POWER)
PIN 6- RESERVED	
PIN 7- BLUE.....	CREDIT_RELAY (N.O.)
PIN 8- PURPLE.....	CREDIT_RELAY (COMMON)
PIN 9- BROWN.....	GND (POWER)
PIN 9 DOTTED- WHITE.....	GND (POWER)

PIN 1- PURPLE.....	CREDIT_RELAY (COMMON)
PIN 2- RED.....	12VDC (POWER)
PIN 3- WHITE.....	ENABLE-
PIN 5- YELLOW.....	INHIBIT+
PIN 10- BROWN.....	GND (POWER)
PIN 16- BLUE.....	CREDIT_RELAY (N.O.)
PIN 18- BLACK.....	ENABLE+
PIN 20- GREEN.....	INHIBIT-

Interface	Used Voltage	Usage
STD Pulse	12V DC	Extension Wire for WEL-RM007
ICT Protocol (RS232)	12V DC	Extension Wire for WEL-RM007
STD Pulse	12V DC	Extension Wire for WEL-RV701
ICT Protocol (RS232)	12V DC	Extension Wire for WEL-RV701

CU-R961-1

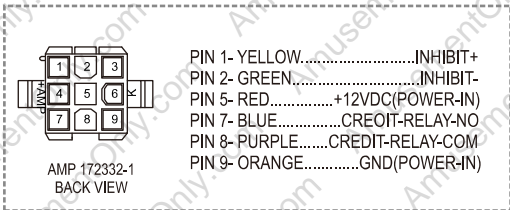
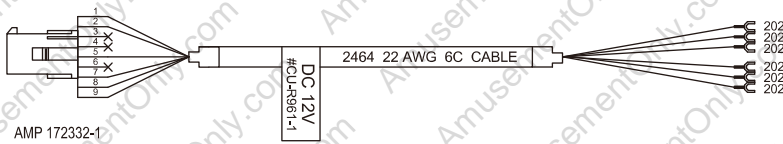

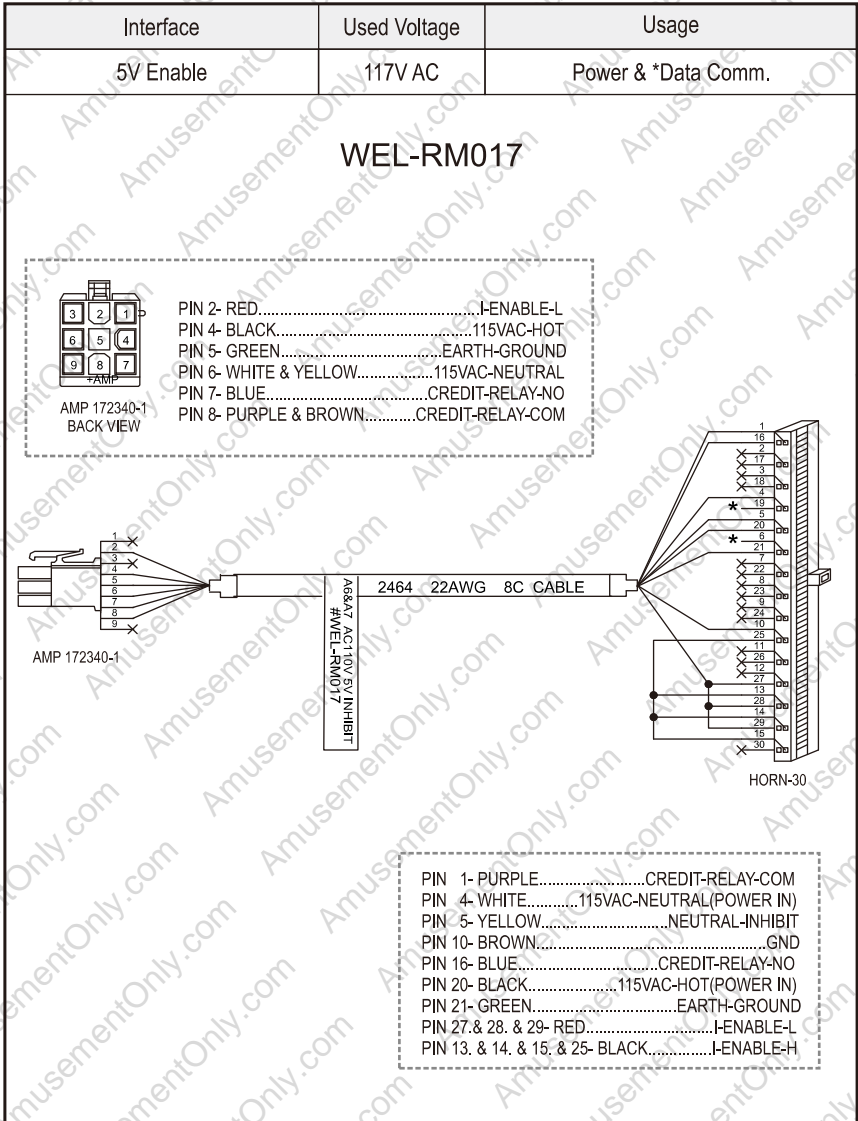

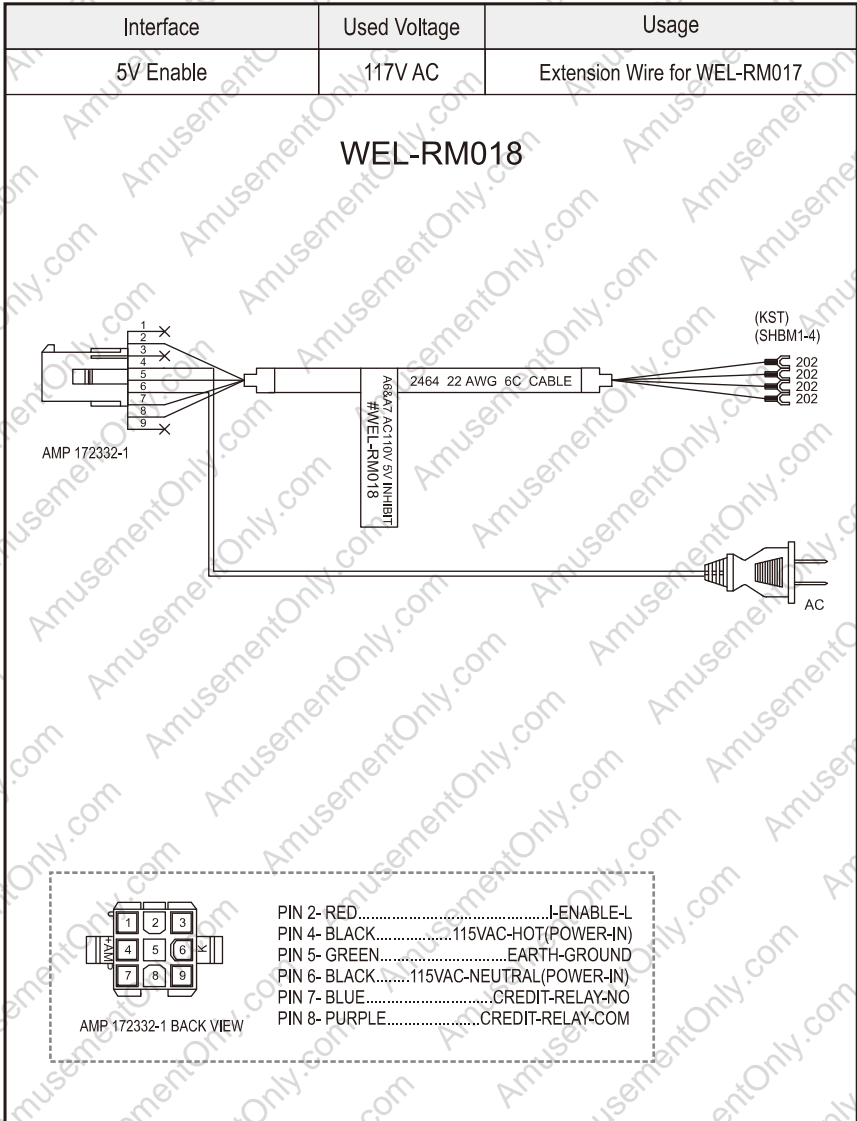

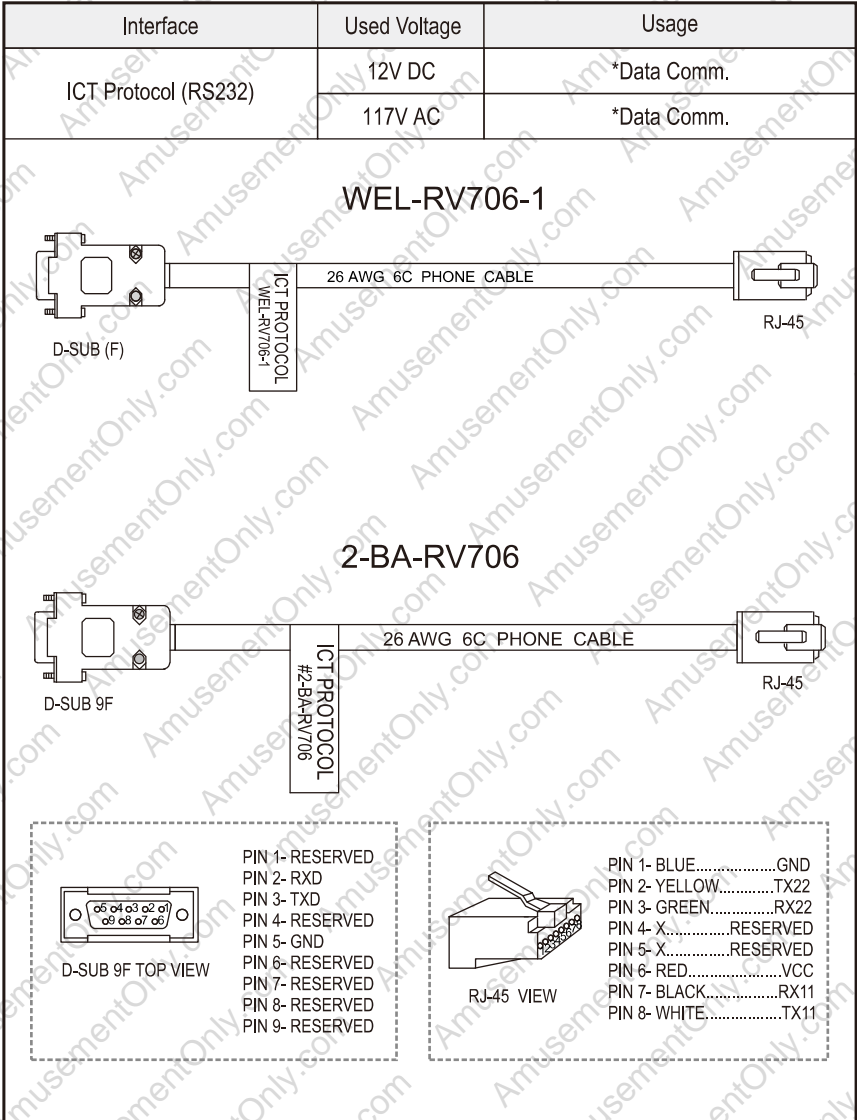

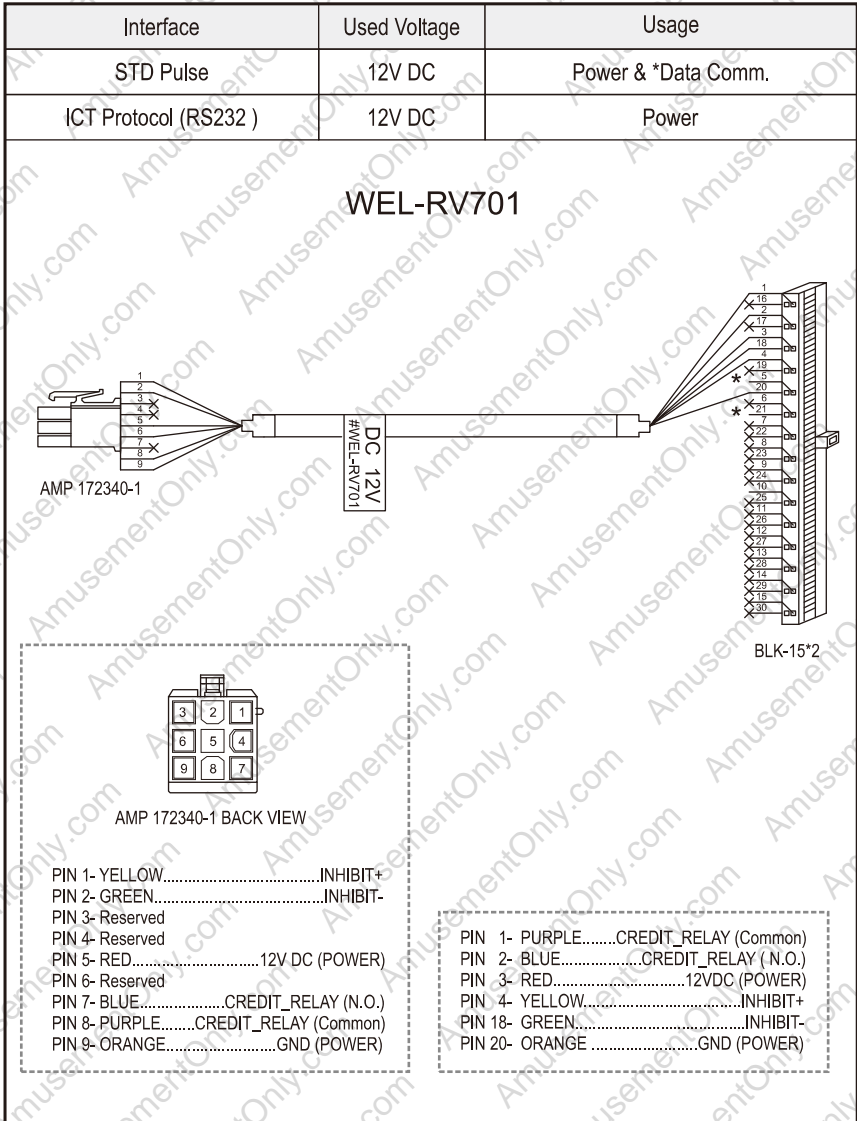

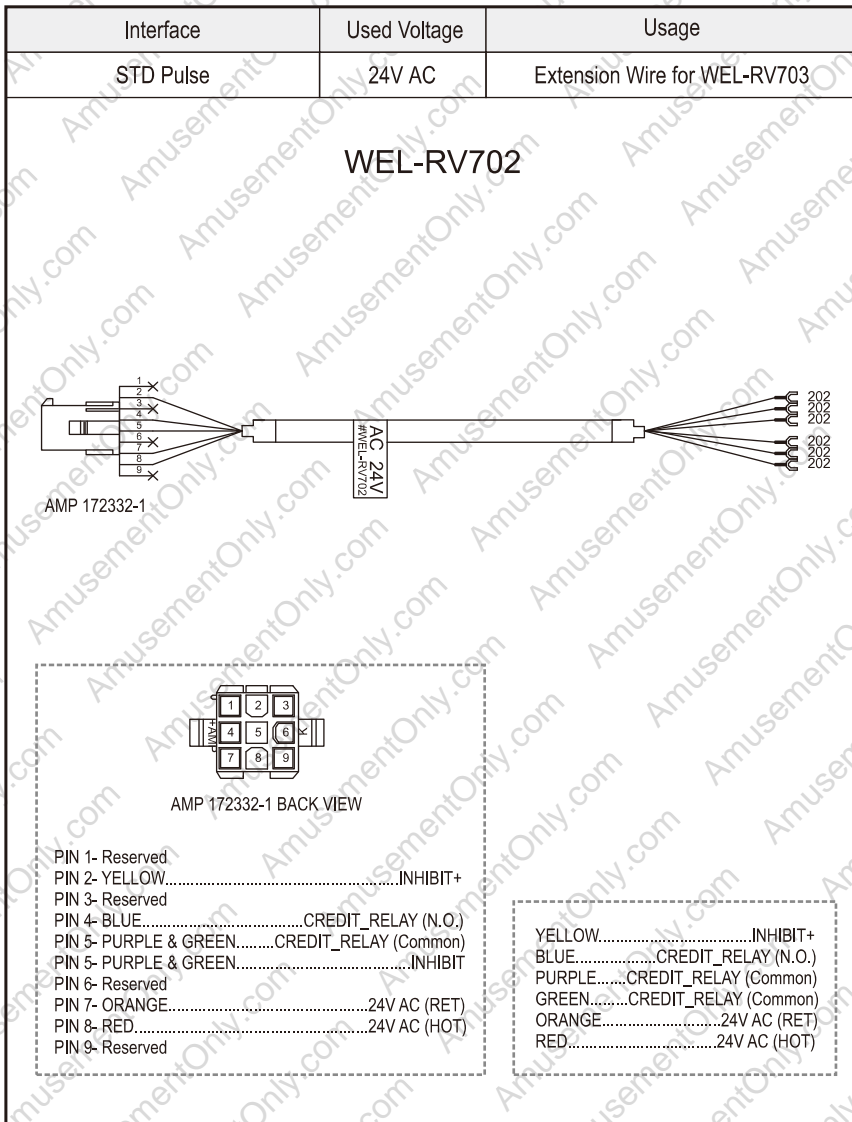

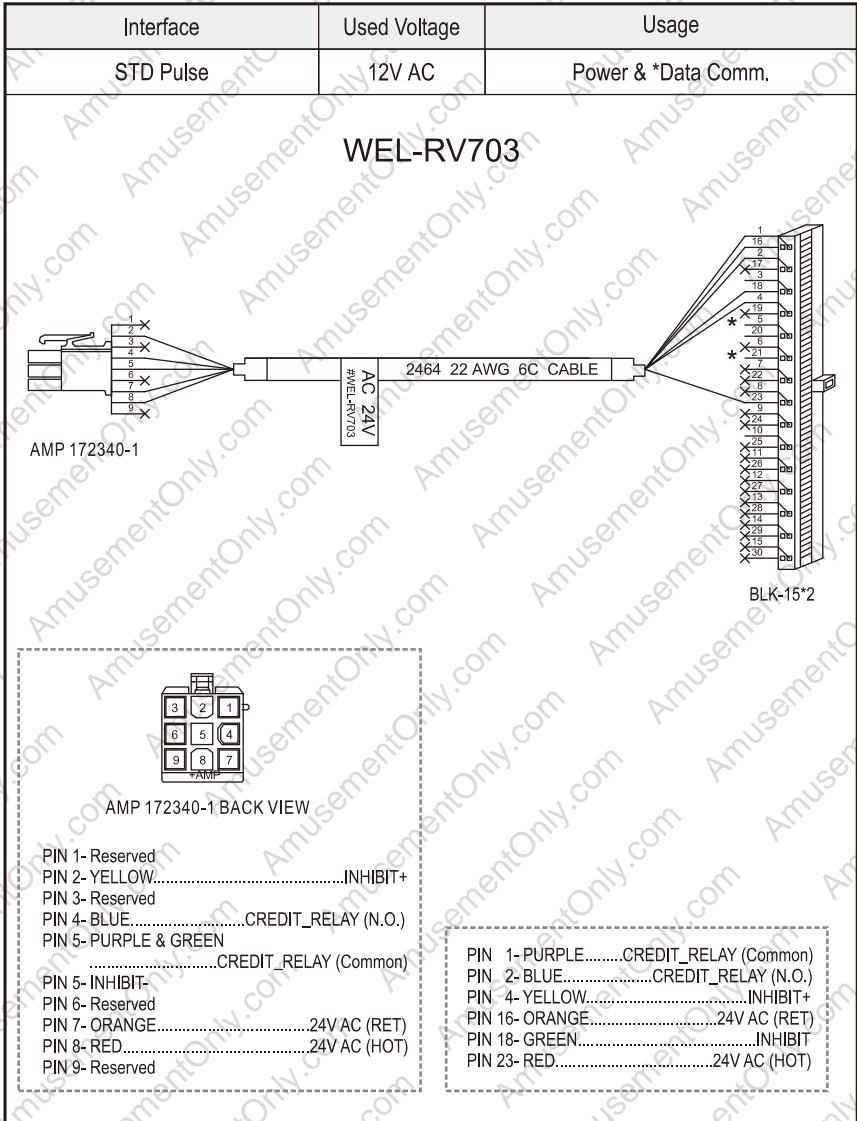

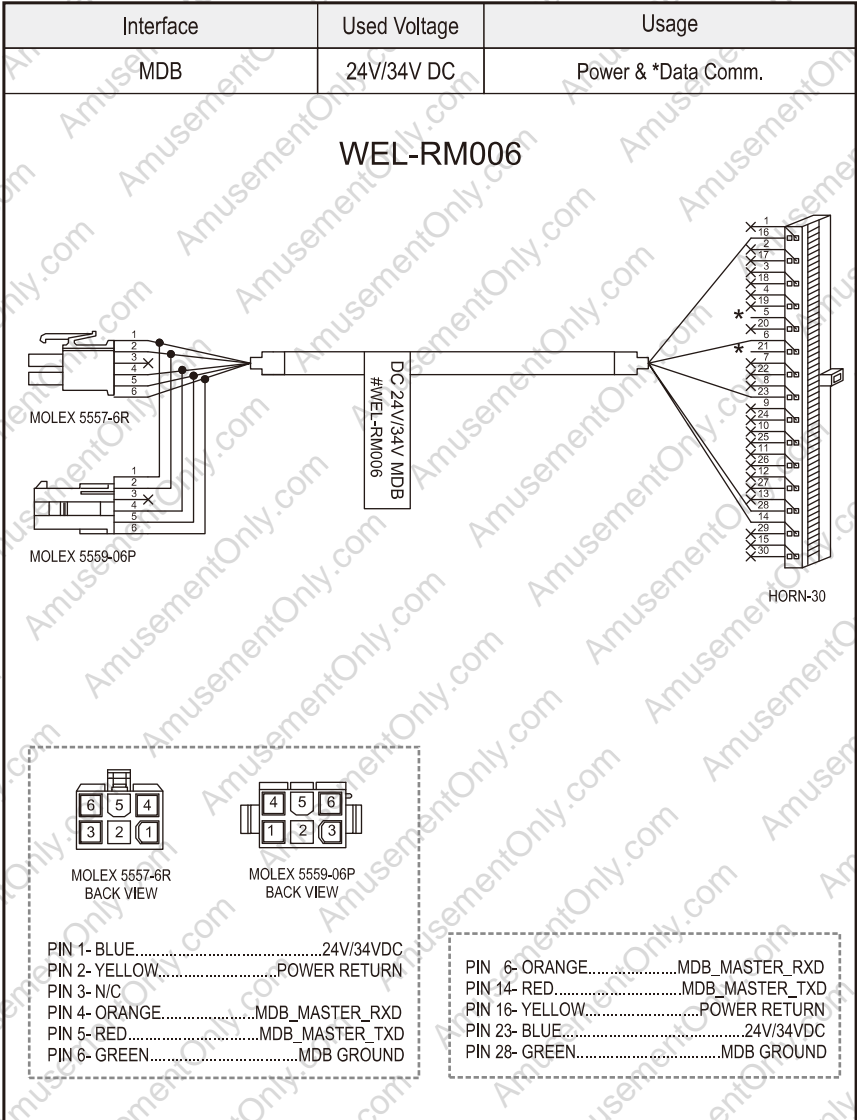

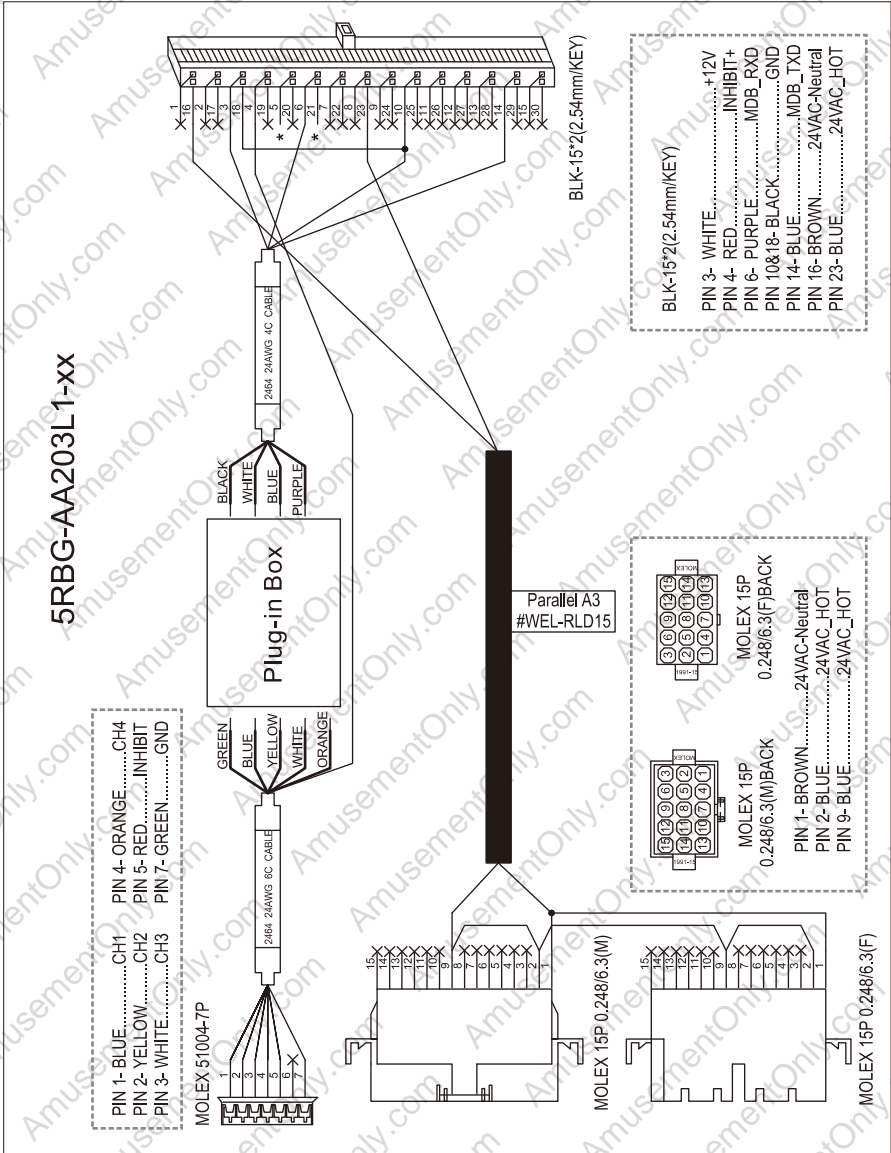

5-1-1. I/O Circuit

Pulse Interface

5-1-1 FIG. 01

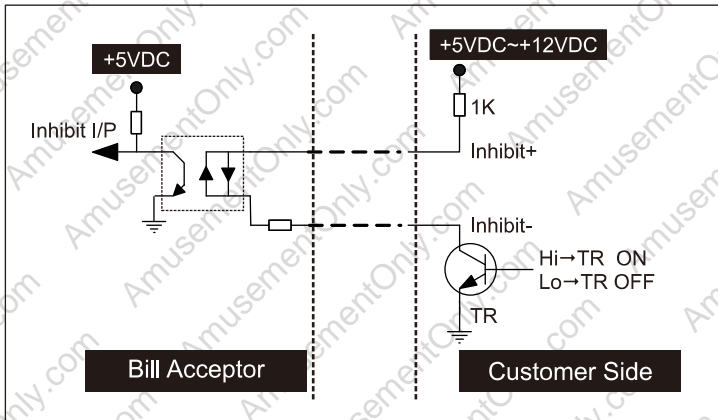
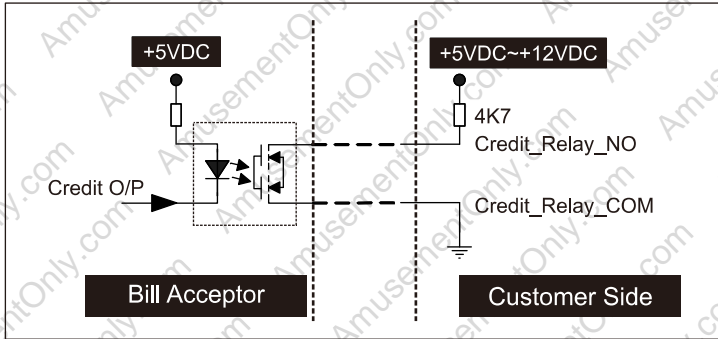

ICT-Protocol Interface

5-1-1 FIG. 02

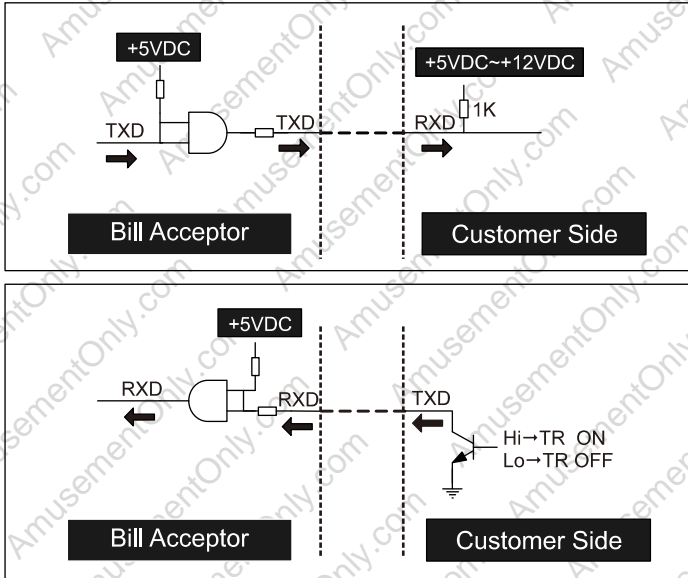

5V Enable Interface

5-1-1 FIG. 03

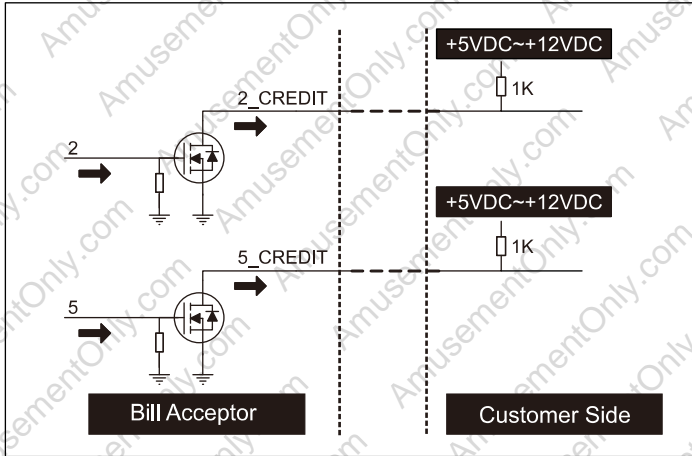

5-1-1 FIG. 03-1

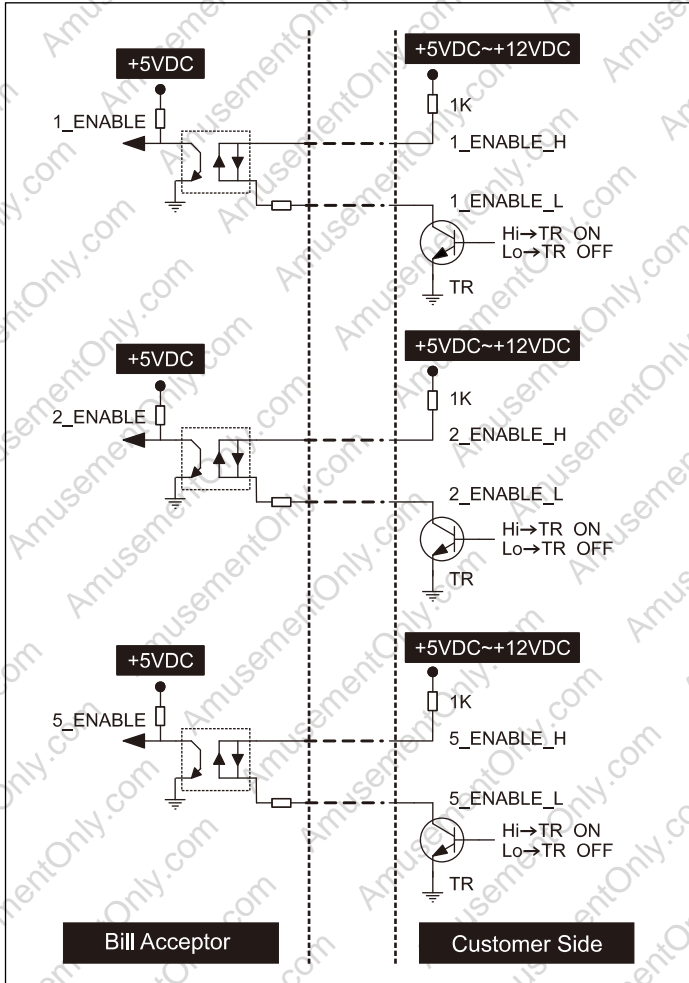

MDB Interface

5-1-1 FIG. 04

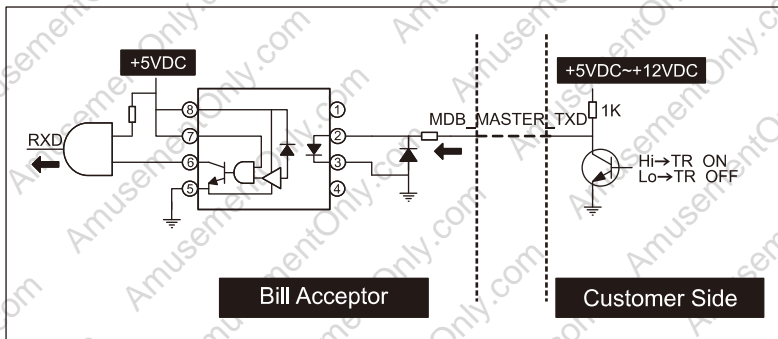
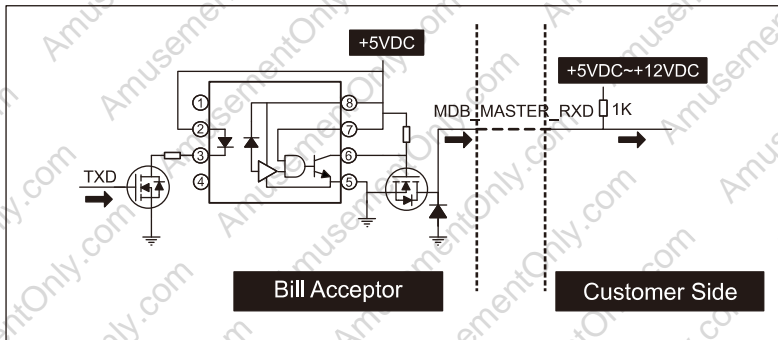

Parallel A3 Interface

5-1-1 FIG. 05

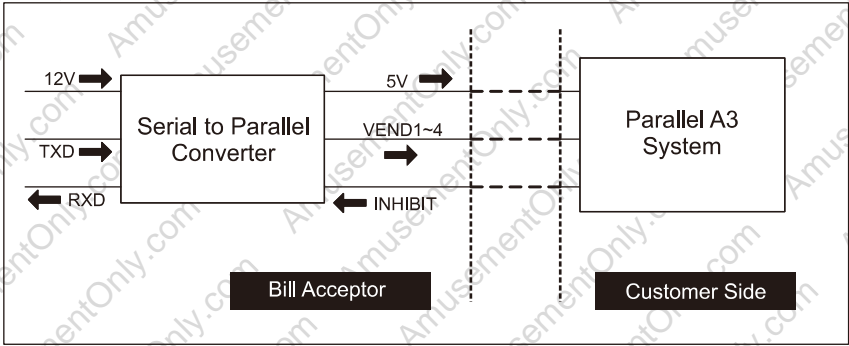

5-2. DIP Switch Setting

There are two serial DIP switches which are located on the side of A7/V7 series(as 5-2 FIG.01). According to different currencies which are used by users, DIP switch settings could be varied to fit users' need. Besides, there's also a serial DIP switches on CPU board inside of A7/V7 series for interface settings.(as 5-2 FIG.02)

Please refer to "A7/V7 series DIP switch setting" guide in the package for more detail.

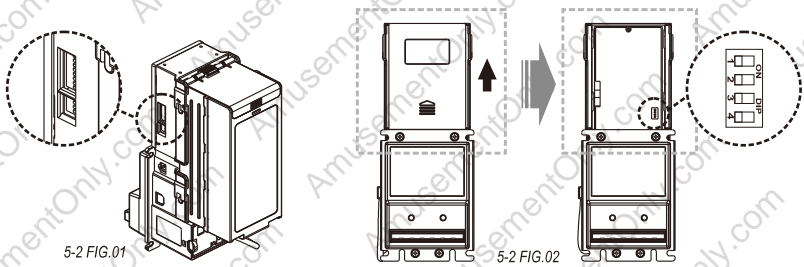

5-3. Software Download and Upgrade

To download and upgrade the software to A7/V7 series, the programmer (FP-004) is needed. Please contact ICT to purchase FP-004 and refer to FP-004 user guide for software download and upgrade information.

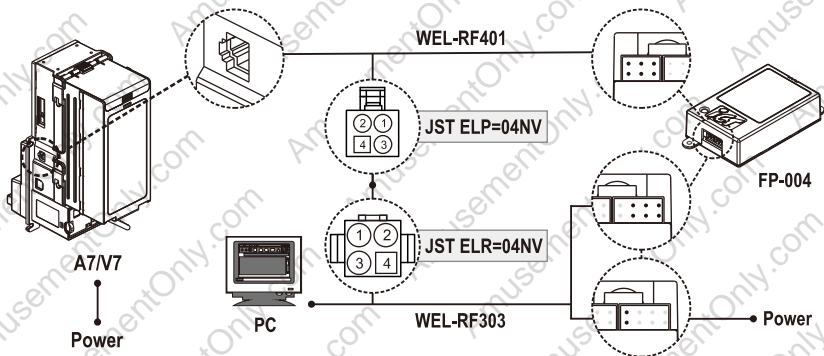

Power must be applied to Bill Acceptor after connecting.

6. Maintenance

To make sure the bill acceptor always works smoothly, please clean the internal parts regularly.

To clean the internal parts:

1. Press the buttons on the sides of bill path unit and pull the unit out.

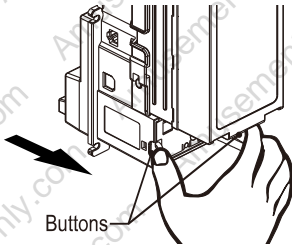

6 FIG.01-1

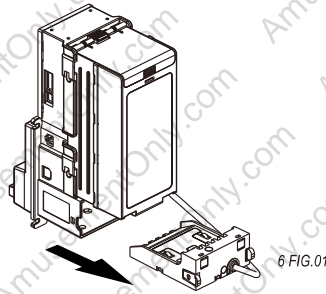

6 FIG.01

2. Use a soft, dry cloth or towel to clean the bill path and sensors.

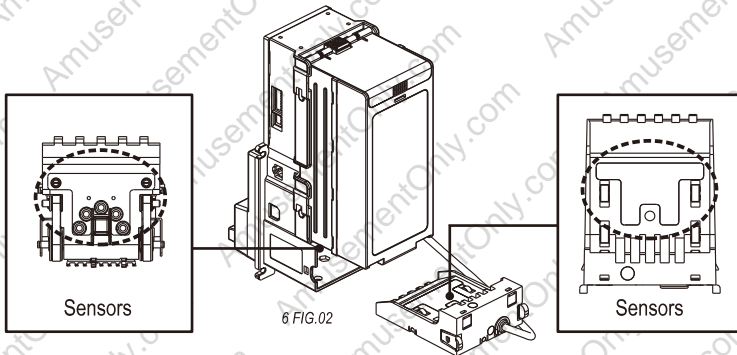

6 FIG.02

	Maintenance Notice	
	<i>(Any improper maintenance will invalidate the warranty.)</i>	
Recommended	Mild, non-abrasive, soap water.	
DO NOT USE	Organic solvent , Alcohol, Volatile liquid.	

7. Troubleshooting

7-1. Back LED Errors

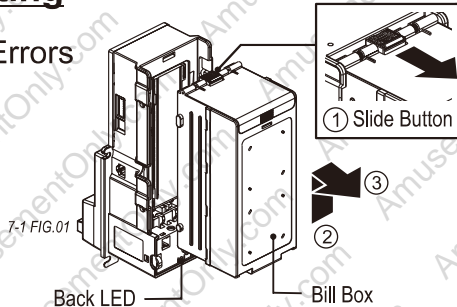

7-1 TABLE 01

LED	Status	Correct Actions
GREEN		
1	White Card Calibration.	Please calibrate with ICT white calibration card.

7-1 TABLE 01-1

LED Flashes	Status	Corrective Actions
GREEN		
1	Bill jammed.	Remove the bill box by sliding the top button and the bill path(as 7-1 FIG.01), and then remove the jammed bill.
2	Disable.	Inspect the right DIP switch setting.
3	Recognition sensor module error.	Inspect the foreign objects on sensor or bill path and clean.
3+2	Hook sensor error.	Inspect the foreign objects on security hook and clean.
4	Anti-string sensor error or a stringing attempt has detected.	Inspect the foreign objects on sensor or bill path and clean.
5	Bill box has been removed.	Replace the bill box.
6	Stacker error or stacker full.	Empty the bill box.
7	Motor error.	Inspect the foreign objects on bill path and clean.



If the error can not be solved after corrective actions or happen again, please contact ICT for technical support.



International Currency Technologies Corporation

No.28, Ln. 15, Sec. 6, Minquan E. Rd., Neihu Dist., Taipei City 114, Taiwan

sales@ictgroup.com.tw (For Sales)

fae@ictgroup.com.tw (For Customer Service)

Website: www.ictgroup.com.tw

