



Bill Acceptor

TK77



Installation Guide

International Currency Technologies Corp.

Use of Materials Limitations

International Currency Technologies Corporation (ICT) all rights reserved.

All materials contained are the copyrighted property of ICT.

All trademarks, service marks, and trade names are proprietary to ICT.

ICT reserves the right at all times to disclose or to modify any information as ICT deems necessary to satisfy any applicable law, regulation, legal process or governmental request, or to edit, refuse to post or to remove any information or materials, in whole or in part, in ICT's sole discretion.

Contents

1. Introduction

1-1. Overview	2
1-2. Features	2

2. Specifications

2

3. Packing List

3

4. Dimension

4

5. Installation

5-1. Pin Assignment	6
5-1-1. I/O Circuit	13
5-2. DIP Switch Setting	15
5-3. Software Download and Upgrade	15

6. Maintenance

16

7. Troubleshooting

7-1. Bezel LED Errors	17
-----------------------------	----

1. Introduction

1-1. Overview

TK77 features a high currency verification and recognition with new verification unit to be a outstanding bill acceptor.

1-2. Features

- Four way bill insertion acceptable.
- High transaction speed.
- Highlight LED bezel.

2. Specifications

General

Acceptance Rate 96% or greater

Note: The incomplete bills such as extremely dirty, wet, broken or wrinkled ones are excluded.

Bill Insertion Four way acceptable

Transaction Speed Approx. 1 sec.

Interface
Pulse
RS232
MDB

Installation
Indoor & Outdoor
Horizontal

Electrical

Power Source	12V DC
Power Consumption	Standby : Approx. 200mA Operation: Approx. 1.4A Maximum: Approx. 2A
Operation Environment	Operation Temperature: -5°C~55°C Storage Temperature: -20°C~70°C Humidity: 30%~85%RH (no condensation)

Mechanical

Outline Dimension	Refer to Page.4
Weight	Approx. 0.75 kg
Bill Accepted Width	63~70mm

3. Packing List

Main	Bill Acceptor
Accessory	Harnesses: Refer to 5-1 TK77 Installation Guide TK77 DIP Switch Setting Guide

4. Dimension

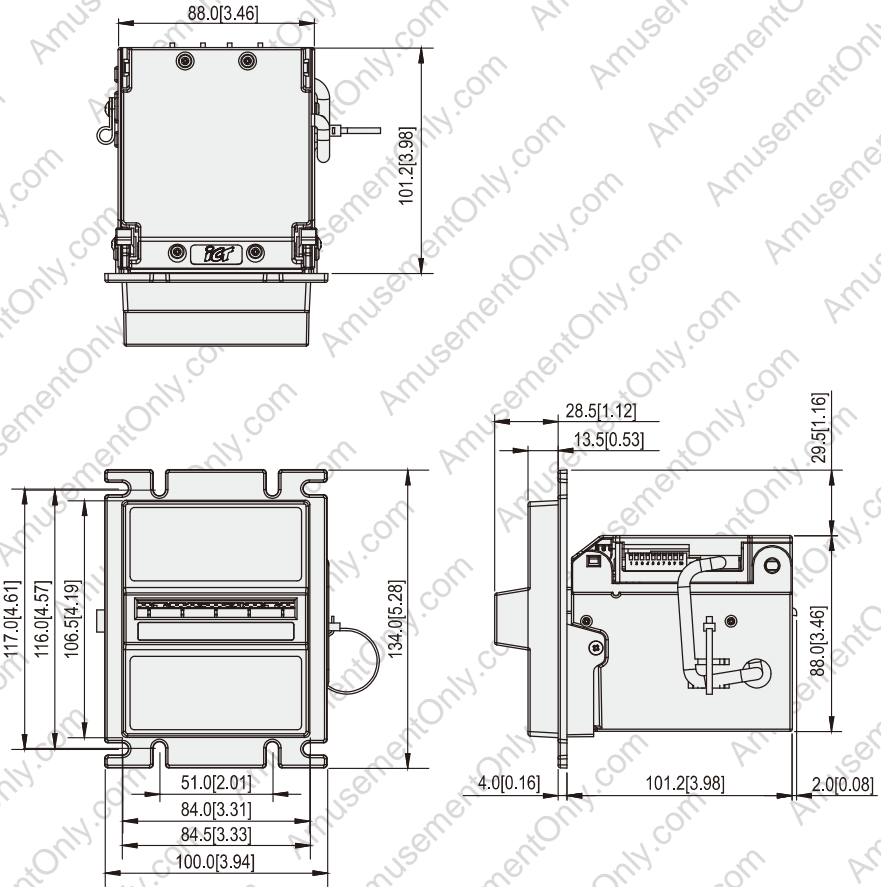

Unit:mm[inch]

4 FIG.01



To install the bill acceptor on your VMC, please be aware of the dimension as below:

[L] : Longer than the maximum length of accepted bills.

[L1] : Bill box capacity depth.

* [L/2] has to be longer than 70mm to open upper base.

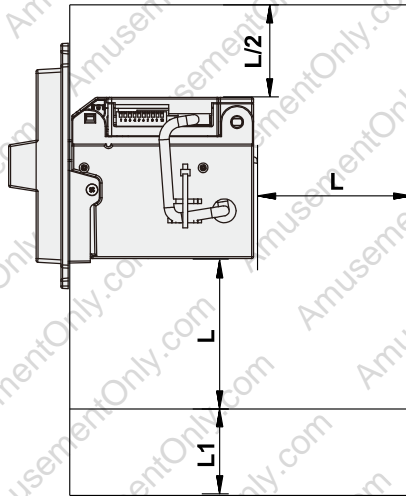

4 FIG.02

5. Installation

5-1. PIN Assignment

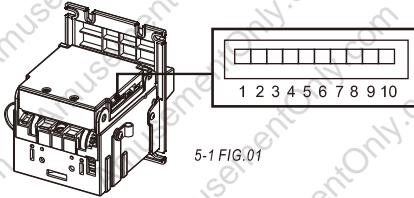

PIN 1-BUSY	PIN 6-ESCROW
PIN 2-VEND1	PIN 7-VEND2
PIN 3-ERR	PIN 8-+12V
PIN 4-NC	PIN 9-+12V
PIN 5-INHIBIT	PIN 10-GND

5-1 TABLE.01

Interface	Used Voltage	Usage	Harnesses	Page
Pulse	12V DC	Power & *Data Comm.	WEL-R0001	7
		Extension Wire	WEL-R0002	7
RS232	12V DC	Power	WEL-R0001	7
		*Data Comm.	WEL-RNK10-1 or 2-BA-RNK10	8
		Extension Wire	WEL-R0002	7
RS232 (UART)	12V DC	Power & *Data Comm.	WEL-R0003	9
		Extension Wire	WEL-R0002 (For UART Only)	9
MDB (Note 1)	12V DC	Power & *Data Comm. (BA ↔ Plug-in Board)	WEL-RTK7708-1	10
	20V~42.5V DC	Power & *Data Comm.(200cm) (Plug-in Board ↔ VMC)	WEL-RBG07	10
		Power & *Data Comm.(35cm) (Plug-in Board ↔ VMC)	WEL-RBG08	11

*Data Comm.=Data Communication

Note 1:

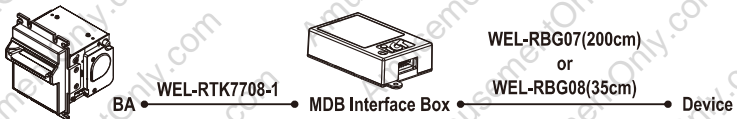

MDB 20V~42.5V DC: VMC Provides +20V~42.5V DC to MDB Plug-in Board to convert into +12VDC, and provides +12VDC to TK77 bill acceptor.

MDB Box: 5RBG-AA313NAB(200cm VMC cable)
5RBG-AA313NAC(35cm VMC cable)

5-1 FIG.02

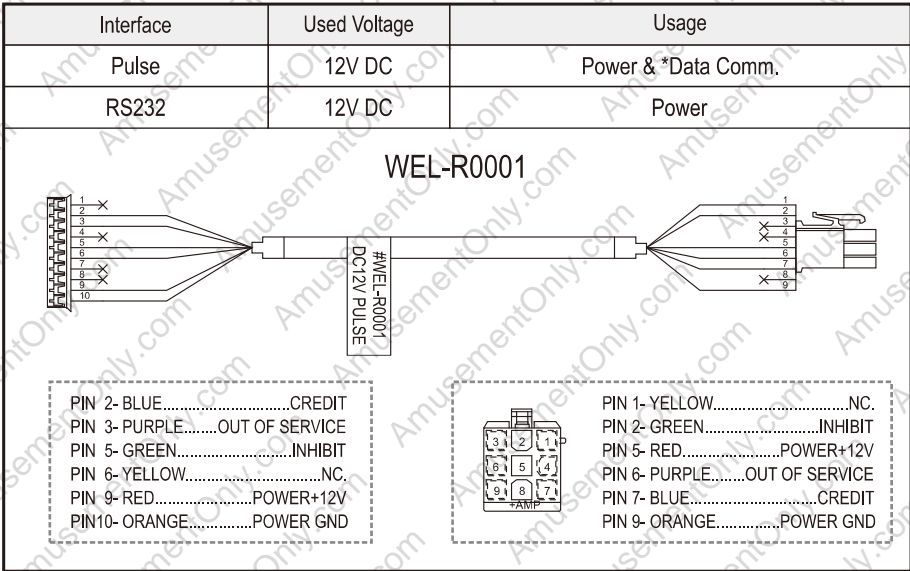

5-1 FIG.03

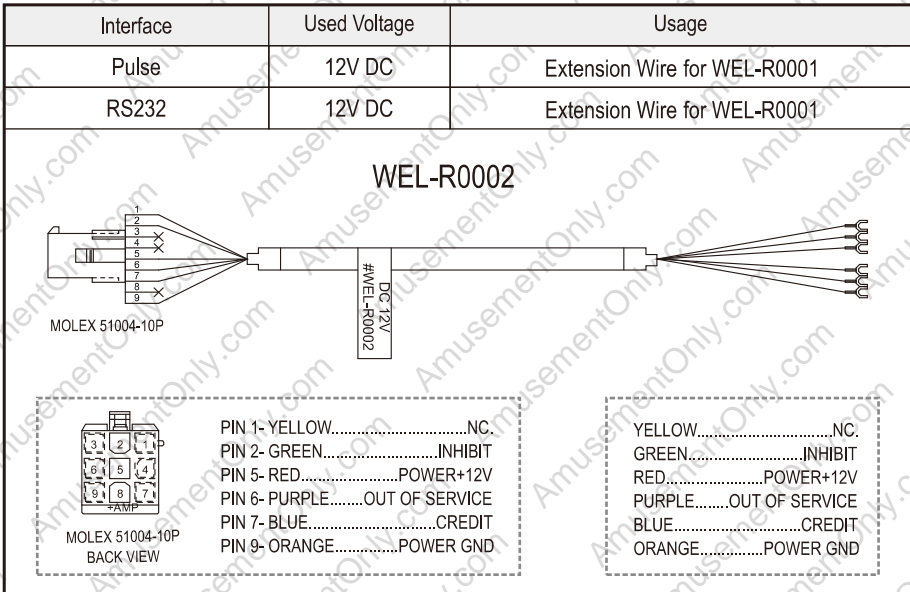

5-1 FIG.04

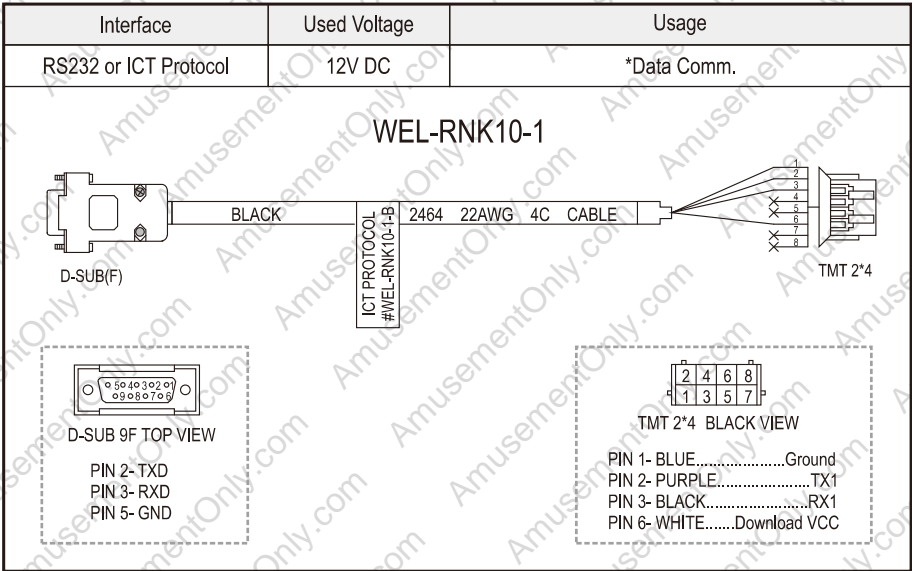

5-1 FIG.05

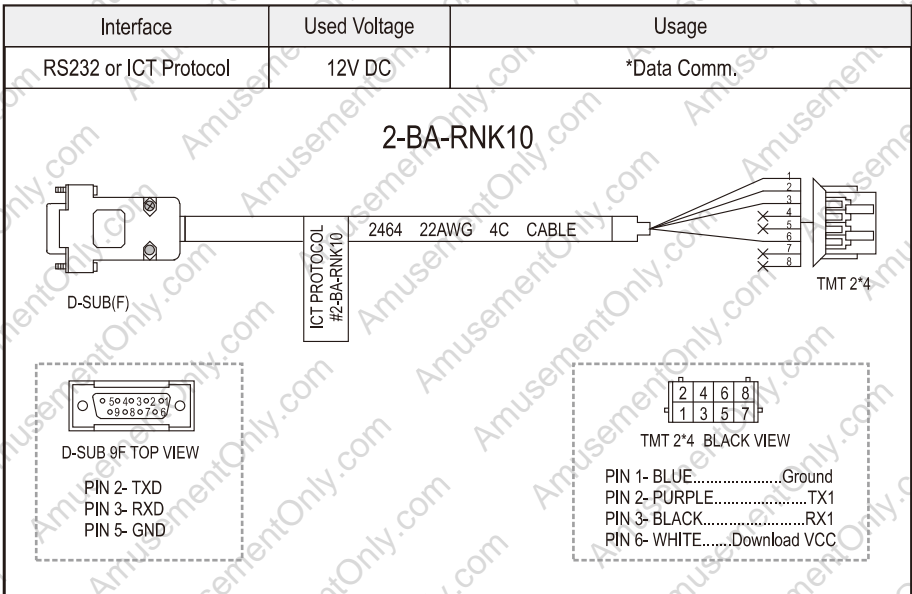

5-1 FIG.06

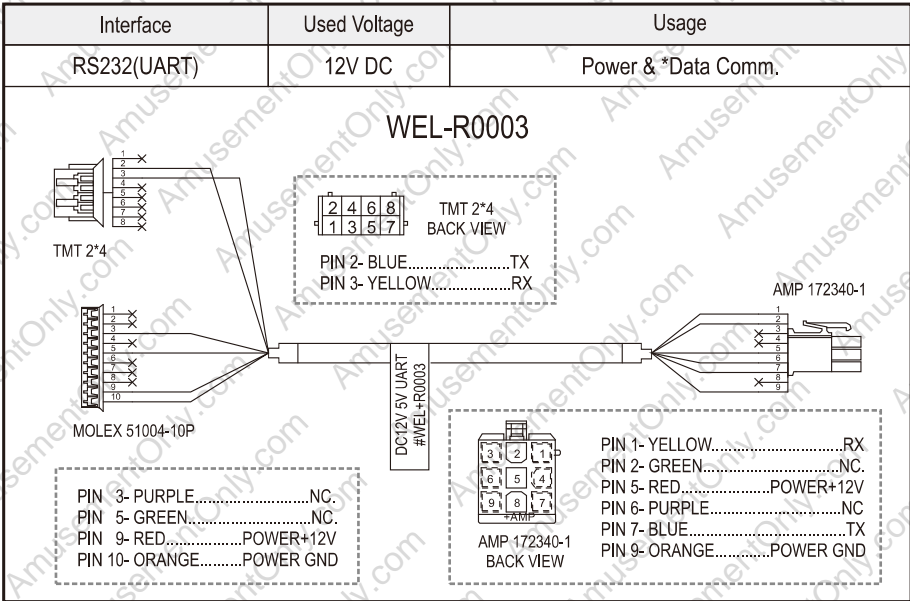

5-1 FIG.07

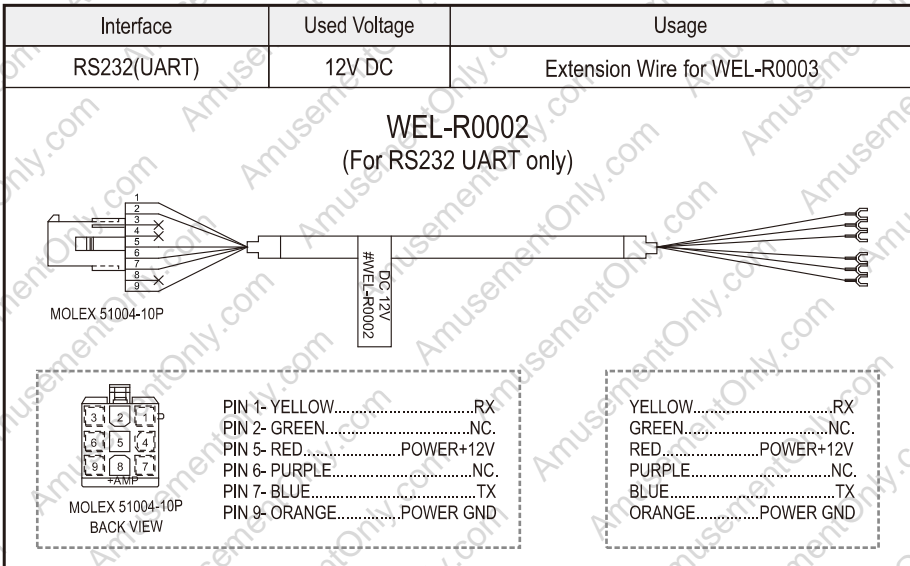

5-1 FIG.08

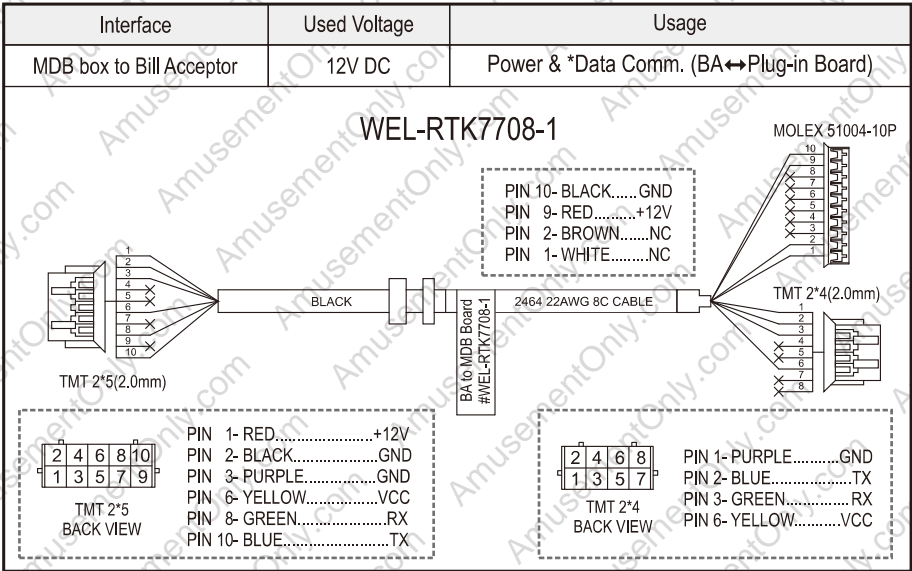

5-1 FIG.09

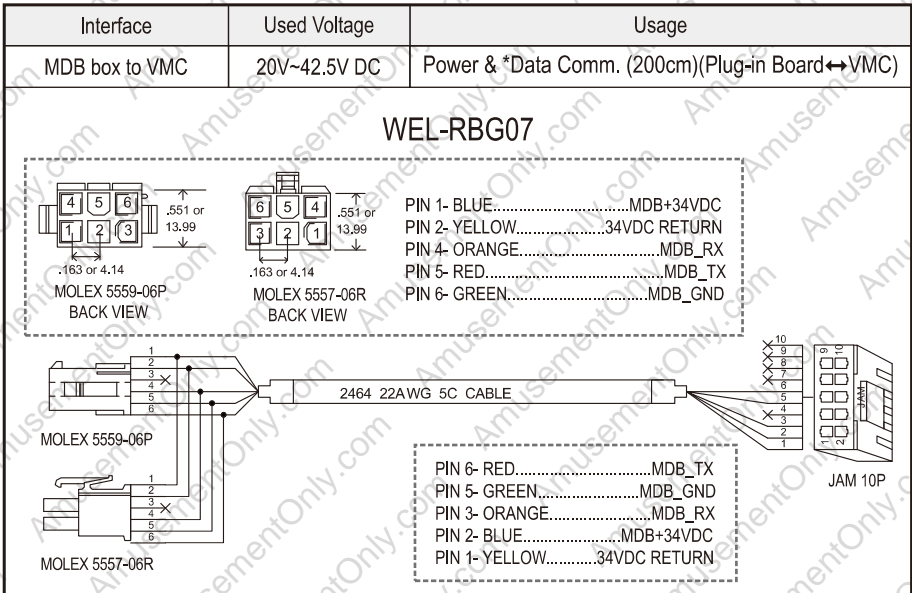

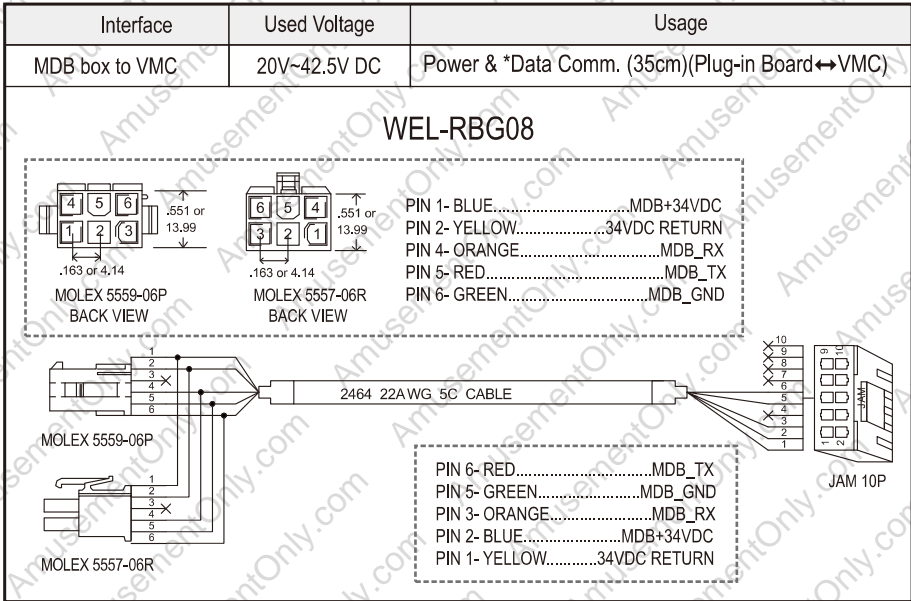

5-1-1. I/O Circuit
Pulse Interface

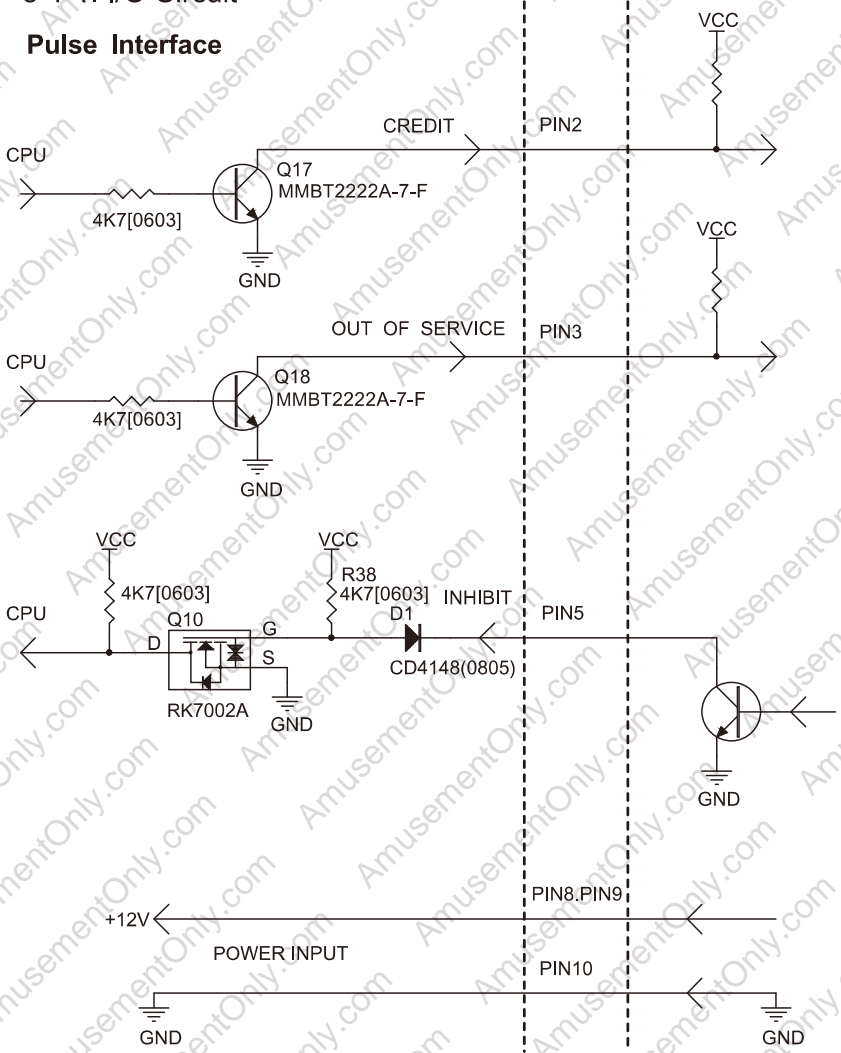

RS232(UART) Interface

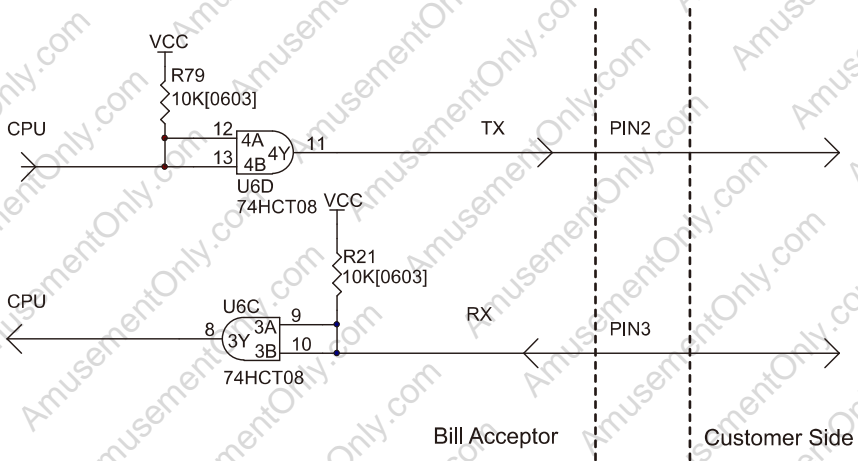

MDB Interface

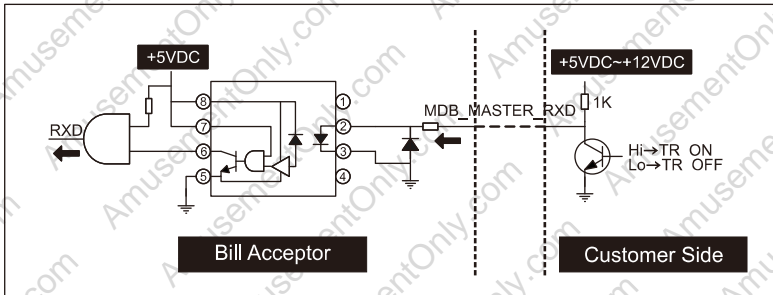
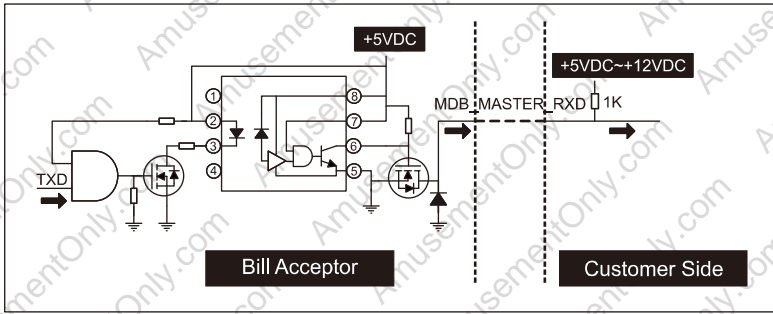

5-2. DIP Switch Setting

There's a serial DIP switches which is located on the side of TK77 (as FIG. 01). According to different currencies or interfaces which are used by users, DIP switch settings could be varied to fit users' needs.

Please refer to "TK77 DIP Switch Setting" Guide in the package for more details.

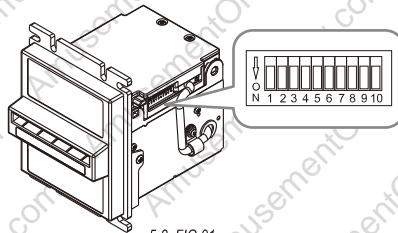

5-2 FIG.01

5-3. Software Download and Upgrade

To download and upgrade the software to TK77, the programmer (FP-004) is needed. Please contact us to purchase FP-004 and refer to FP-004 user guide for software download and upgrade information.

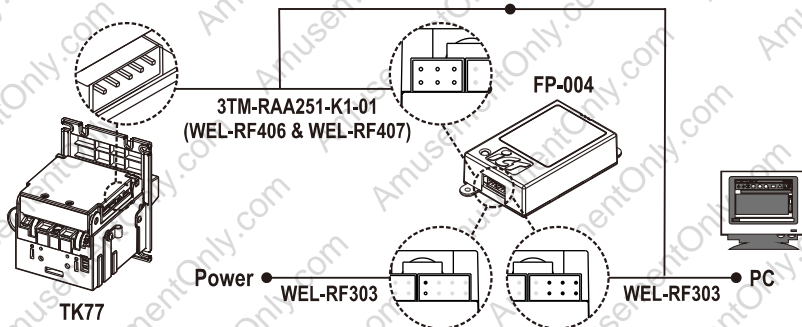

Turn on Bill Acceptor after connecting.

6. Maintenance

To make sure the bill acceptor always works smoothly, please clean the internal parts regularly.

To clean the internal parts:

1. Press the buttons on the sides of bill path and lift the unit up.
2. Use a soft, dry cloth, or towel to clean the bill path and sensors.

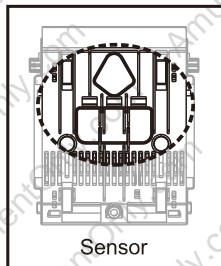

6 FIG.01-1

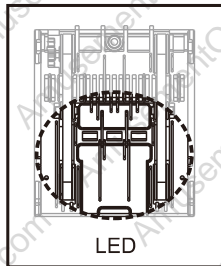

6 FIG.01-2

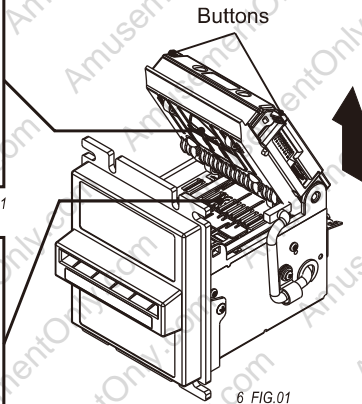

6 FIG.01



Maintenance Notice

(Any improper maintenance will result invalid warranty.)

Recommended	Mild, non-abrasive, soap water.
DO NOT USE	Organic solvent , Alcohol, Volatility liquid.

7. Troubleshooting

7-1. Bezel LED Errors

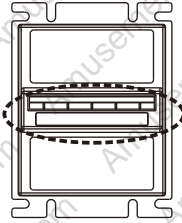

7-1 FIG.01

7-1 TABLE 01

Flashes		Meaning	Solutions
Red	Blue		
1	1	Indicate that something has jammed the bill path.	Inspect for foreign object or banknote.
2	1	Indicate that Bill acceptor is not enable.	Please inspect dip switch setting.
3	0	Indicate that bill acceptor is having input sensor problem.	Please inspect or clean any foreign object on sensor or on bill path.
3	1	Indicates that the unit is having recognize sensor problem.	Please inspect or clean any foreign object on sensor or on bill path.
3	2	Indicates that the unit is having hook sensor problem.	Remove LED housing: Inspect for foreign object and clean on Security hook.
3	4	Indicates that the unit is having output sensor problem.	Inspect for dirt or foreign object on sensor or on bill path.
4	1	Indicates that the unit has detected fishing issue.	Inspect for dirt or foreign object on sensor or on bill path.
7	1	Indicates that the unit is having motor problem.	Inspect for dirt or foreign object on sensor or on bill path.



If the error can not be solved after corrective actions or happen again, please contact us for technical support.

TK77

Bill Acceptor



International Currency Technologies Corporation

No.28, Ln. 15, Sec. 6, Minquan E. Rd., Neihu Dist., Taipei City 114, Taiwan

sales@ictgroup.com.tw (For Sales)

fae@ictgroup.com.tw (For Customer Service)

Website: www.ictgroup.com.tw

