



Bill Acceptor

TAO-A/V I

Series

Installation Guide

International Currency Technologies Corp.

Use of Materials Limitations

International Currency Technologies Corporation (ICT) all rights reserved.

All materials contained are the copyrighted property of ICT.

All trademarks, service marks, and trade names are proprietary to ICT.

ICT reserves the right at all times to disclose or to modify any information as ICT deems necessary to satisfy any applicable law, regulation, legal process or governmental request, or to edit, refuse to post or to remove any information or materials, in whole or in part, in ICT's sole discretion.

Contents

1. Introduction

1-1. Overview	2
1-2. Features	2

2. Specifications	2
--------------------------------	----------

3. Packing List	4
------------------------------	----------

4. Dimension	5
---------------------------	----------

5. Installation

5-1. Harness Application	7
5-1-1. I/O Circuit	20
5-2. DIP Switch Setting	26
5-3. Software Download and Upgrade	26

6. Maintenance	27
-----------------------------	-----------

7. Troubleshooting

7-1. Bezel LED Errors	28
7-2. Back LED Errors	29

1. Introduction

1-1. Overview

TAO-A/V I series is a bill acceptor which features a lockable bill box for high-security with acceptance rate up to 96% or greater.

1-2. Features

- Four way bill insertion acceptance.
- Auto-calibrating.
- Win XP/Vista and Linux compatible USB interface available.
- Secure, lockable, and removable bill box is available for 200, 500 and 1000 bills capacity.

2. Specifications

General

Acceptance Rate	96 % or greater
Bill Insertion	Four way acceptable
Transaction Speed	Approx. 3 seconds to stack
Interface	TAO-A I: Pulse, 5V ENABLE, NISR, ICT Protocol ,Single Price. TAO-V I: Pulse, MDB, ICT Protocol.



Installation: Indoor use only!!

Electrical**Power Source**

TAO-A I: 12V DC (10.8V~ 13.2V DC)
117V AC (105.3V~128.7V AC)

TAO-V I: 12V DC (10.8V~ 13.2V DC)
24V AC (21.6V~ 26.4V AC)
34V DC (20V~ 42.5V DC)

Power Consumption

TAO-A I: 12V DC- Standby : 0.3A, 4W
Operation: 0.9A, 11W
Maximum: 2.6A, 32W
117V AC- Standby : 0.04A, 5W
Operation: 0.12A, 15W
Maximum: 0.4A, 47W

TAO-V I: 12V DC- Standby : 0.3A, 4W
Operation: 0.8A, 10W
Maximum: 2.5A, 30W
24V AC- Standby : 0.2A, 5W
Operation: 0.5A, 12W
Maximum: 1.5A, 36W
34V DC- Standby : 0.15A, 6W
Operation: 0.4A, 14W
Maximum: 1.35A, 46W

Operation Environment

Operation Temperature: 0°C~55°C
Storage Temperature : -30°C~70°C
Humidity: 30%~85% RH(no condensation)

Mechanical

Bill Capacity

TAO-A/V I-P2 : 200 bills
TAO-A/V I-P5 : 500 bills
TAO-A/V I-P10:1000 bills

Outline Dimension

Refer to page.5

Weight

TAO-A/V I-P2 : Approx. 1.22kg
TAO-A/V I-P5 : Approx. 1.35kg
TAO-A/V I-P10: Approx. 1.72kg

Bill Accepted Width

62mm~66mm

3. Packing List

Main

Bill Acceptor

Accessory

Harnesses: Refer to 5-1
TAO-A/V I series Installation Guide
TAO-A/V Switches Setting Guide
Key for bill box
Bezel Sticker

4. Dimension

TAO-A/V I-P2/ P5

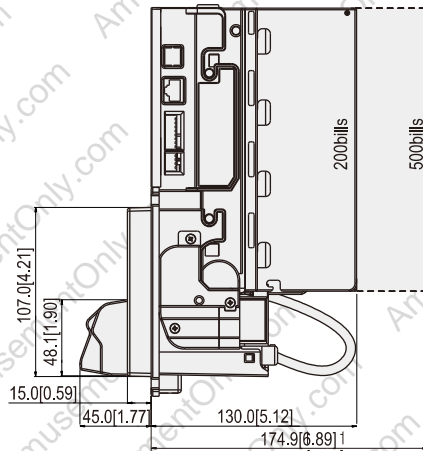
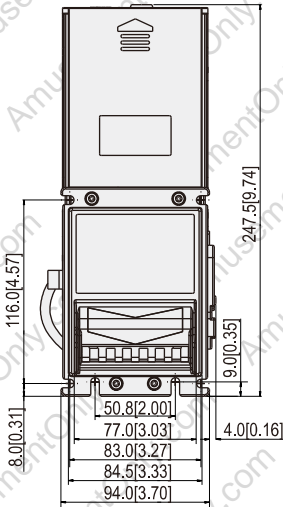
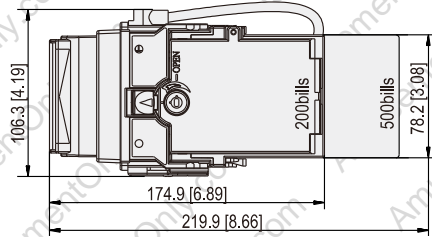

Unit : mm [inch]

4 FIG.01

TAO-A/WI

TAO-AV I-P10

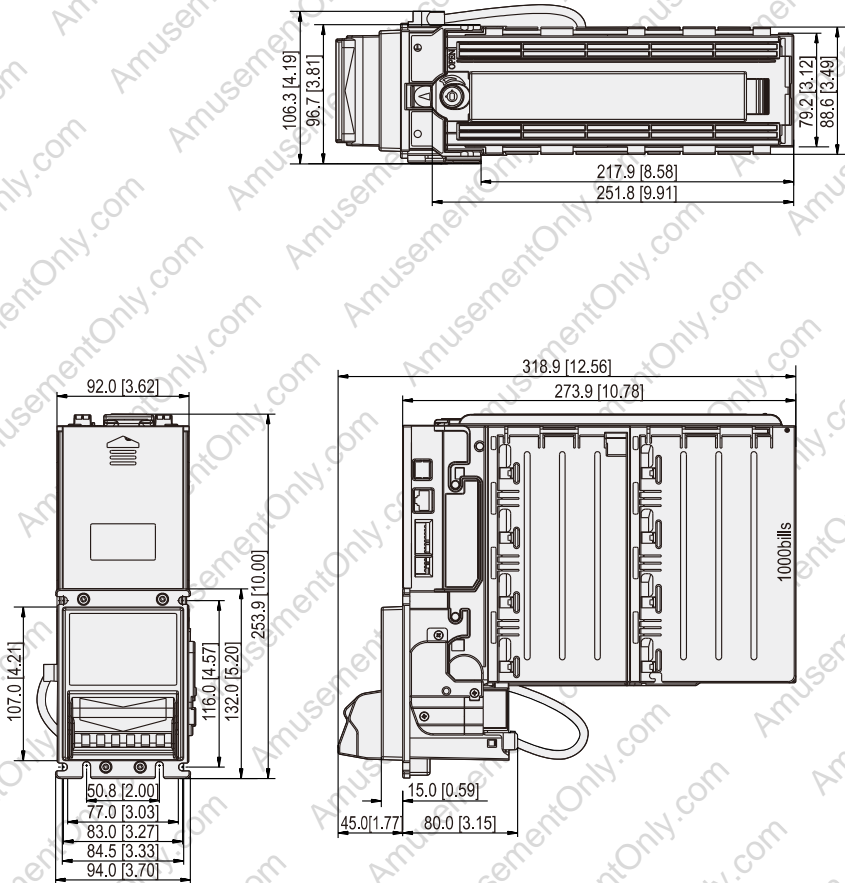

Unit : mm [inch]

4 FIG.02

5. Installation

5-1. Harness Application

5-1 TABLE 01

Model	Interface	Used Voltage	Usage	Harness	Page
TAO-AI	Standard Pulse	117V AC	Power & *Data Comm.	WEL-RM008	8
			Extension Wire	WEL-RM012	9
		12V DC	Power & *Data Comm.	WEL-RM007	10
			Extension Wire	CU-R961-1	11
	5V ENABLE	117V AC	Power & *Data Comm.	WEL-RM017	12
			Extension Wire	WEL-RM018	13
	RS232 for ICT Protocol & RS232 A0	12V DC	Power	WEL-RM007	10
			Power Extension Wire	CU-R961-1	11
		117V AC	*Data Comm.	WEL-RV706-1 or 2-BA-RV706	14
			Power	WEL-RM008	8
		117V AC	Power Extension Wire	WEL-RM012	9
			*Data Comm.	WEL-RV706-1 or 2-BA-RV706	14
	NISR	117V AC	Power & *Data Comm.	WEL-RM023	15
	Single Price	117V AC	Power & *Data Comm.	WEL-RM031	16
USB for ICT Protocol	-	*Data Comm.	WEL-RU1180	17	
TAO-VI	Standard Pulse	12V DC	Power & *Data Comm.	WEL-RV701	18
			Extension Wire	CU-R961-1	11
	MDB	34V DC	Power & *Data Comm.	WEL-RM006	19
			Power	WEL-RV701	18
	RS232 for ICT Protocol & RS232 A0	12V DC	Power Extension Wire	CU-R961-1	11
			*Data Comm.	WEL-RV706-1 or 2-BA-RV706	14
USB for ICT Protocol	-	*Data Comm.	WEL-RU1180	17	

* Data Comm. : Data Communication.

Interface	Used Voltage	Usage
Standard Pulse	117V AC	Power & *Data Comm.
RS232 for ICT Protocol & RS232 A0	117V AC	Power

WEL-RM008

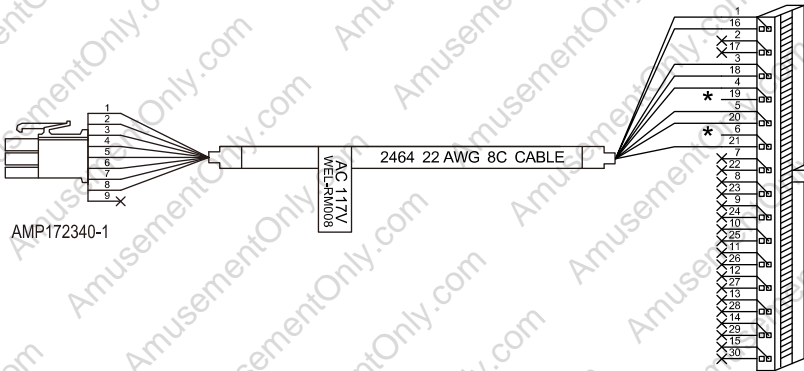

AMP172340-1

- PIN 1- YELLOW.....NEUTRAL INHIBIT
- PIN 2- RED.....NEUTRALE NABLE
- PIN 3- BROWN.....HOT ENABLE
- PIN 4- BLACK.....117VAC HOT(Power)
- PIN 5- GREEN.....Earth-Ground
- PIN 6- WHITE.....117VAC NEUTRAL(Power)
- PIN 7- BLUE.....CREDIT_RELAY(N.O.)
- PIN 8- PURPLE.....CREDIT_RELAY(Common)

- PIN 1- PURPLE.....CREDIT_RELAY(Common)
- PIN 3- RED.....NEUTRALENABLE
- PIN 4- WHITE.....117VACNEUTRAL(Power)
- PIN 5- YELLOW.....NEUTRALINHIBIT
- PIN 16- BLUE.....CREDIT_RELAY(N.O.)
- PIN 18- BROWN.....HOTENABLE
- PIN 20- BLACK.....117VACHOT(Power)
- PIN 21- GREEN.....EARTHGROUND

Interface	Used Voltage	Usage
Standard Pulse	117V AC	Extension Wire for WEL-RM008
RS232 for ICT Protocol & RS232 A0	117V AC	Power Extension Wire for WEL-RM008

WEL-RM012

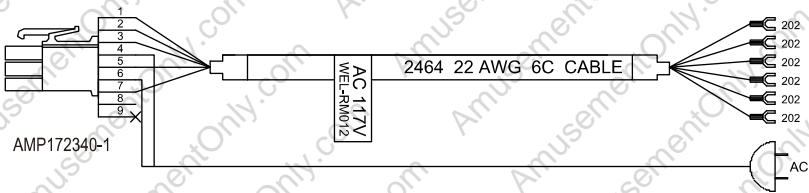

- PIN 1- YELLOW.....NEUTRAL INHIBIT+
- PIN 2- RED.....NEUTRAL INHIBIT-
- PIN 3- ORANGE.....HOT ENABLE
- PIN 4- BLACK.....117VAC HOT (Power)
- PIN 5- GREEN.....Earth - Ground
- PIN 6- BLACK.....117VAC NEUTRAL (Power)
- PIN 7- BLUE.....CREDIT_RELAY (N.O.)
- PIN 8- PURPLE...CREDIT_RELAY (Common)
- PIN 9- Reserved

- PURPLE.....CREDIT_RELAY (Common)
- BLUE.....CREDIT_RELAY (N.O.)
- GREEN.....Earth - Ground
- ORANGE.....HOT ENABLE
- RED.....NEUTRAL INHIBIT-
- YELLOW.....NEUARAL INHIBIT+

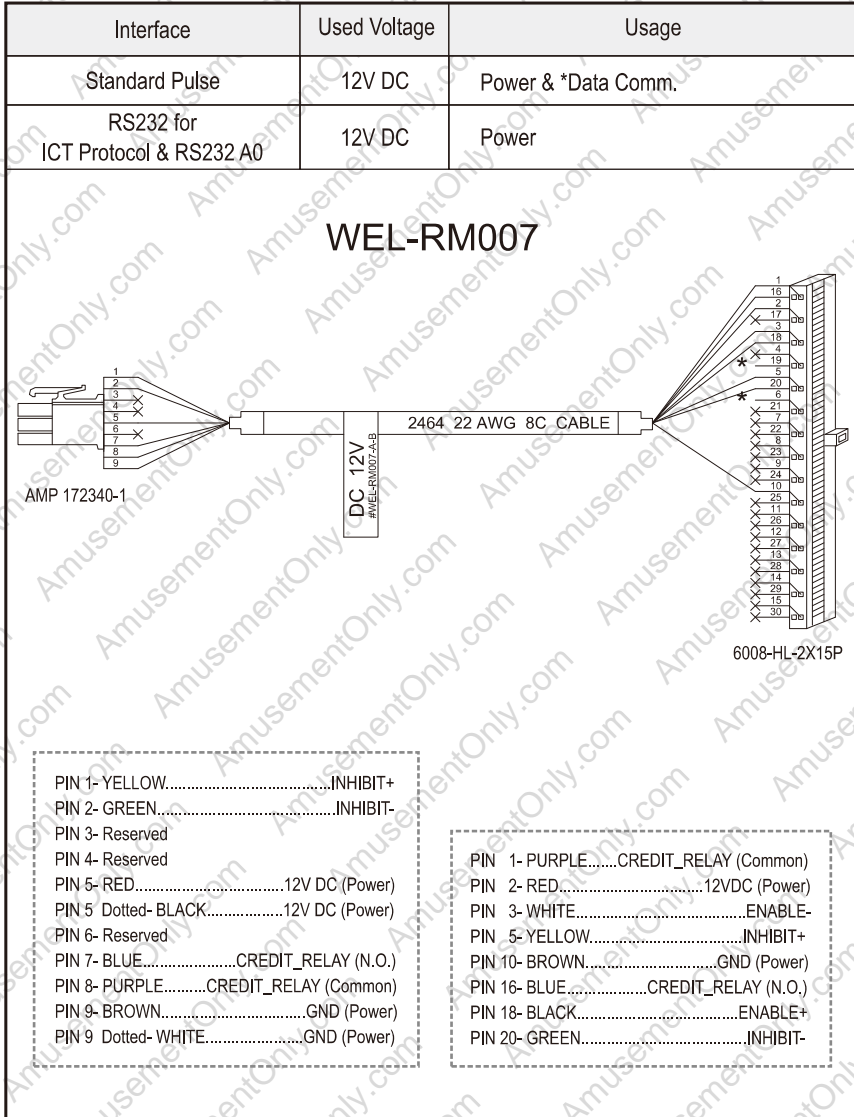

5-1 FIG.04

Interface	Used Voltage	Usage
Standard Pulse	12V DC	Extension Wire for WEL-RM007
Standard Pulse	12V DC	Extension Wire for WEL-RV701
RS232 for ICT Protocol & RS232 A0	12V DC	Power Extension Wire for WEL-RM007
RS232 for ICT Protocol & RS232 A0	12V DC	Power Extension Wire for WEL-RV701

CU-R961-1

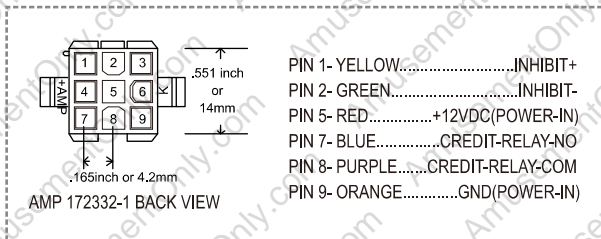
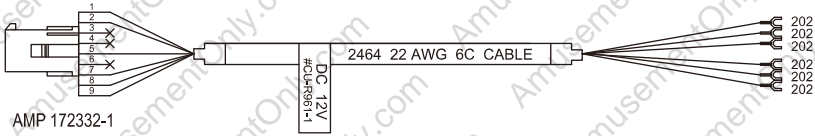

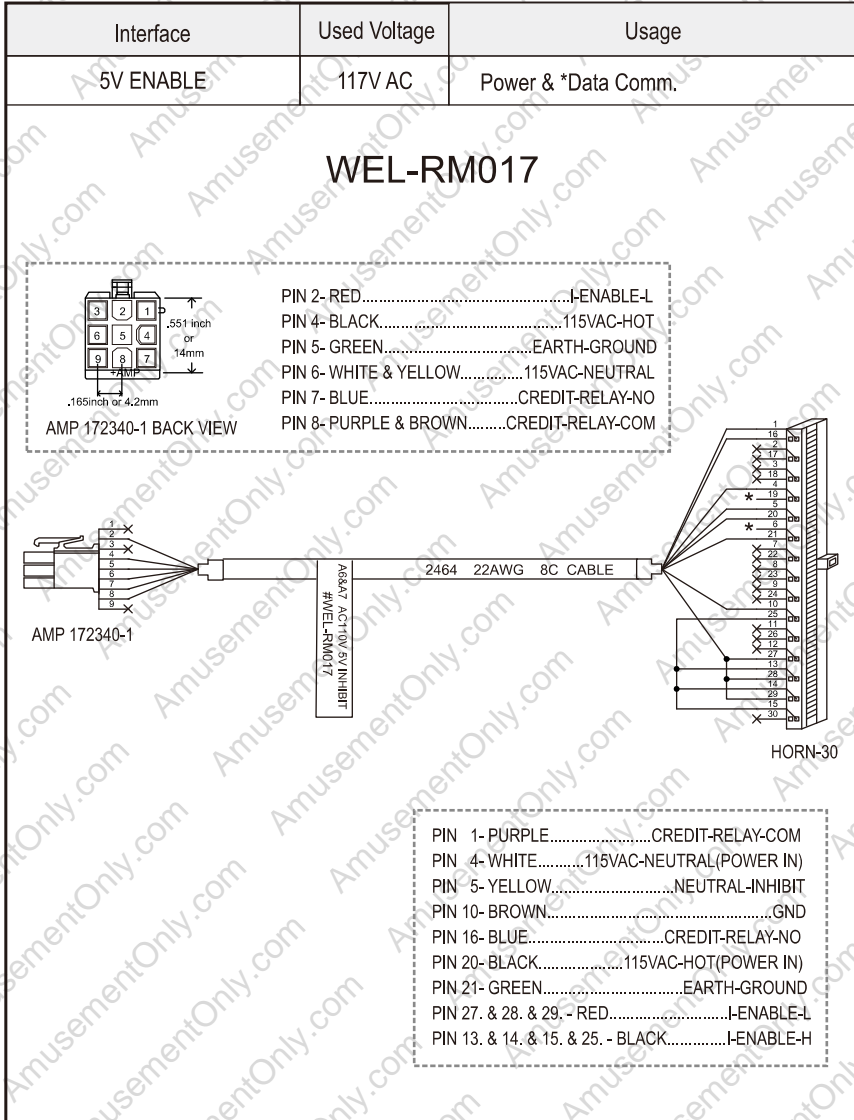

5-1 FIG.06

Interface	Used Voltage	Usage
5V ENABLE	117V AC	Extension Wire for WEL-RM017

WEL-RM018

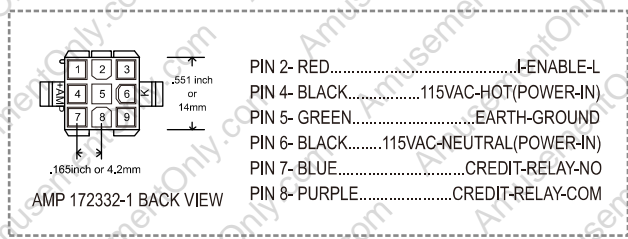
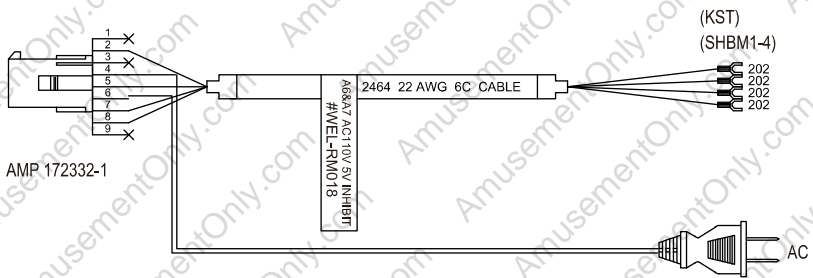

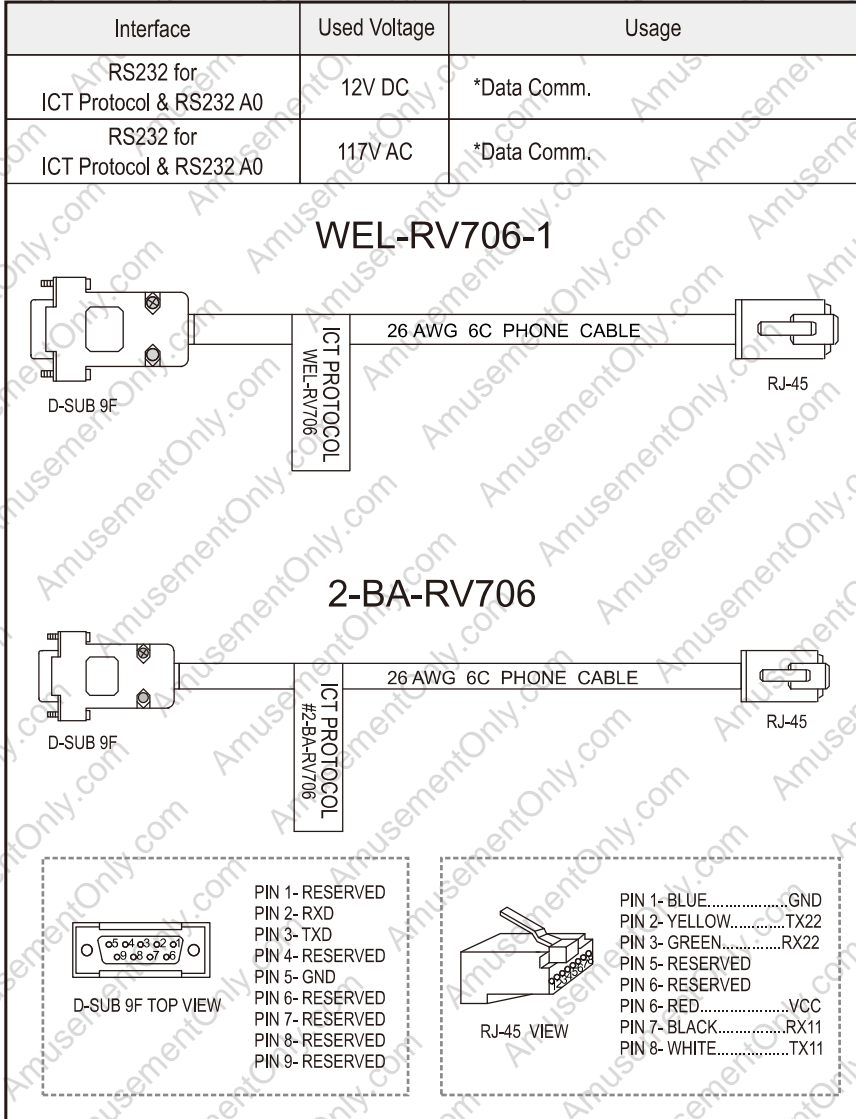

Interface	Used Voltage	Usage
NISR	117V AC	Power & *Data Comm.

WEL-RM023

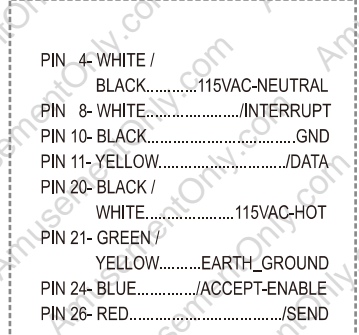
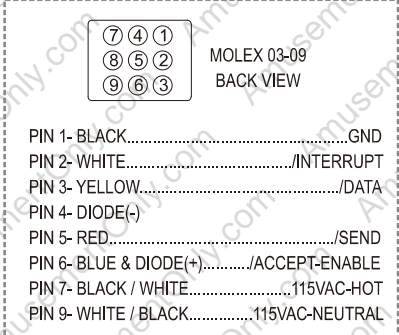
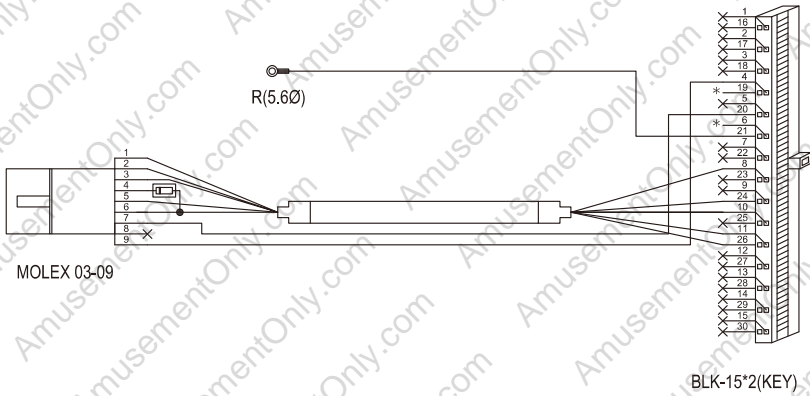

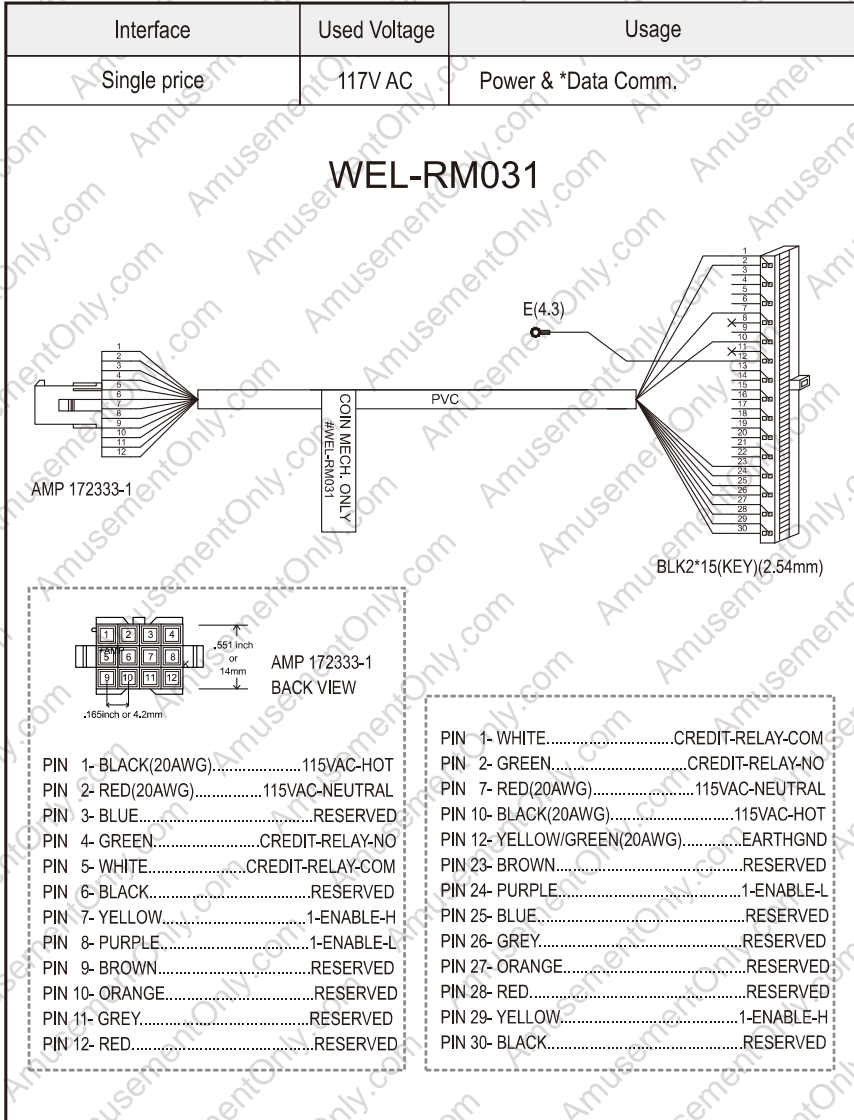

5-1 FIG.10

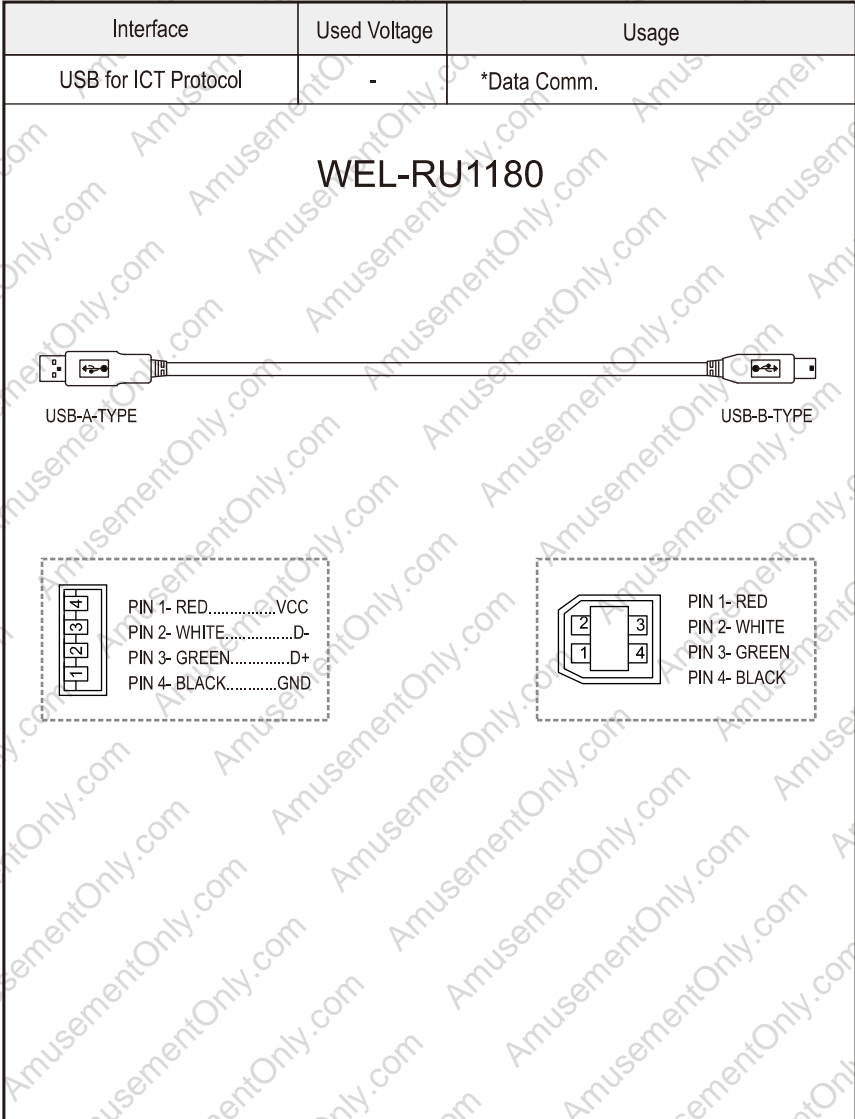

Interface	Used Voltage	Usage
Standard Pulse	12V DC	Power & *Data Comm.
RS232 for ICT Protocol & RS232 A0	12V DC	Power

WEL-RV701

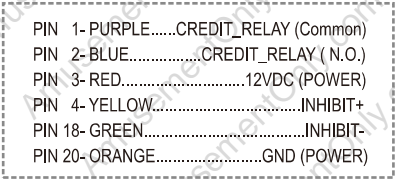
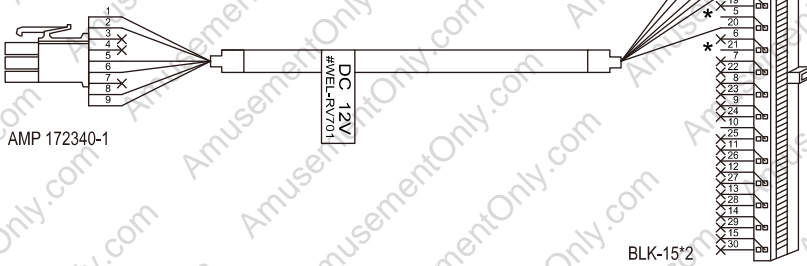
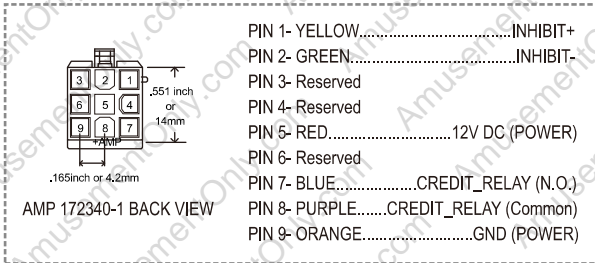

5-1 FIG.12

Interface	Used Voltage	Usage
MDB	34V DC	Power & *Data Comm.

WEL-RM006

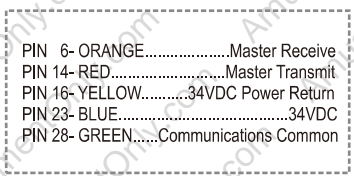
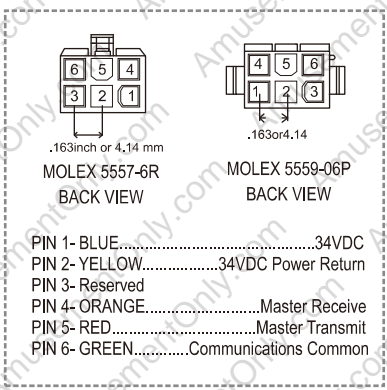
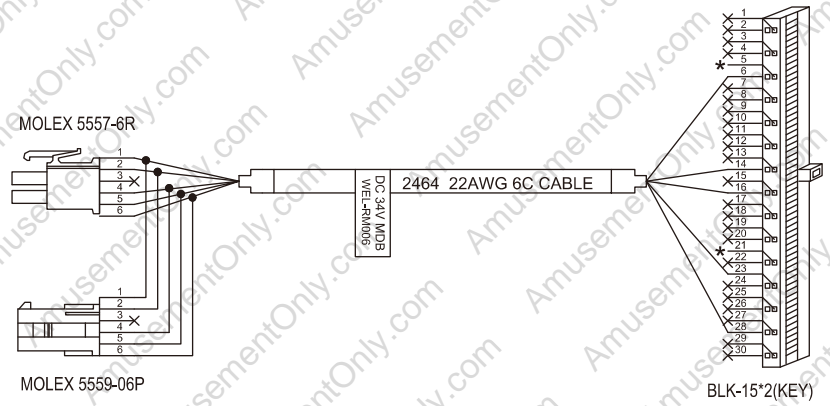

5-1-1. I/O Circuit

Pulse Interface.

5-1-1 FIG.01

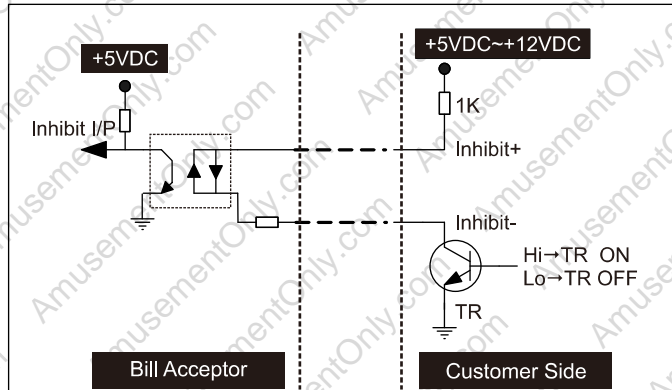
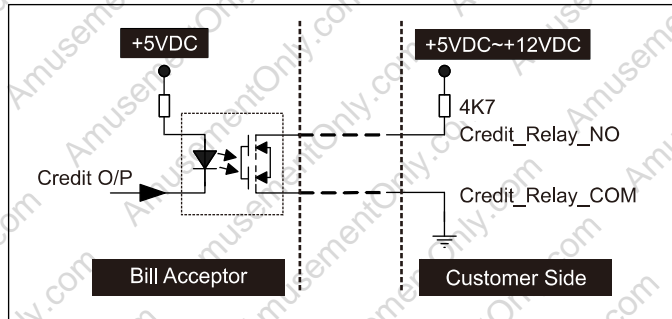

BA Status	*DIP SW Setting	Control Signal
Inhibit	Inhibit Active	Low
		High
Enable	Inhibit Active	Low
		High

*Note: Please refer to DIP Switch Setting Guide for detail.

5V Enable Interface-1

5-1-1 FIG.02-1

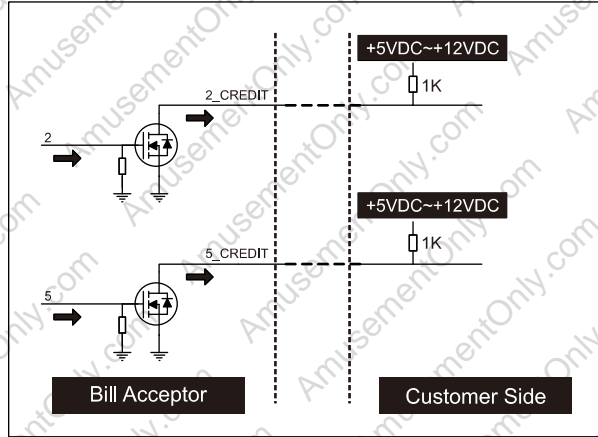

5V Enable Interface-2

5-1-1 FIG.02-2

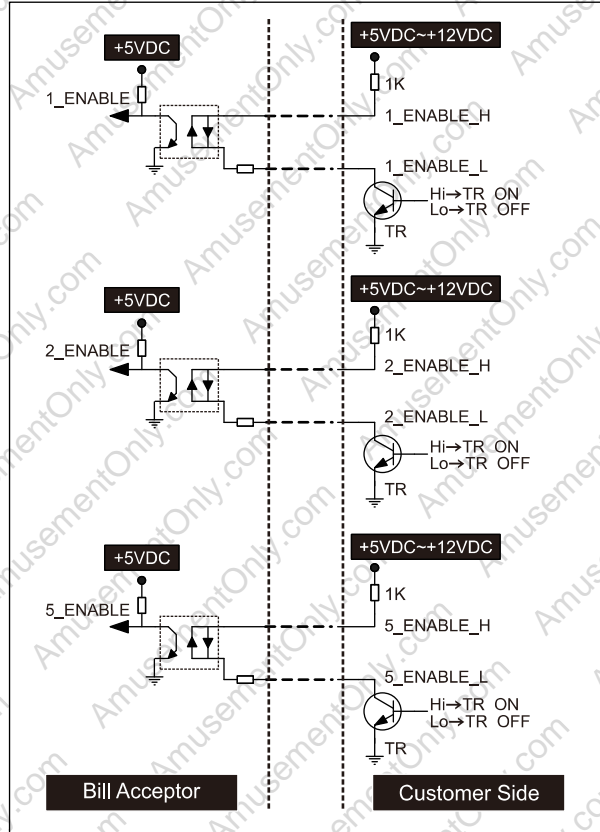

ICT Protocol Interface.

5-1-1 FIG.03

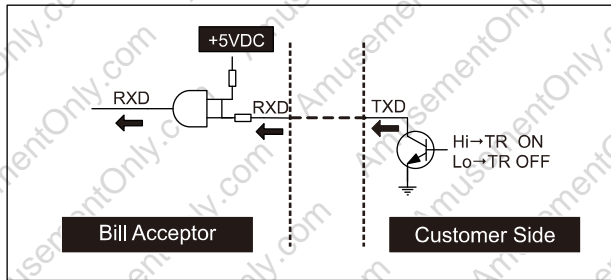
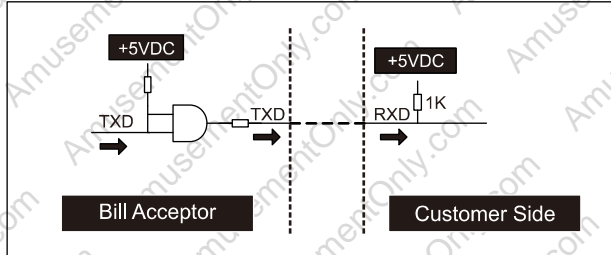

NISR Interface.

5-1-1 FIG.04

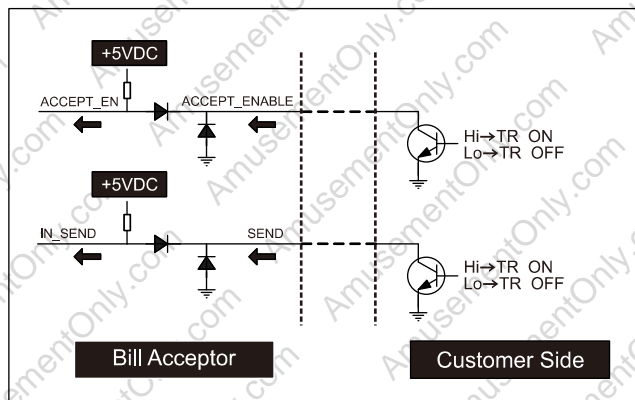
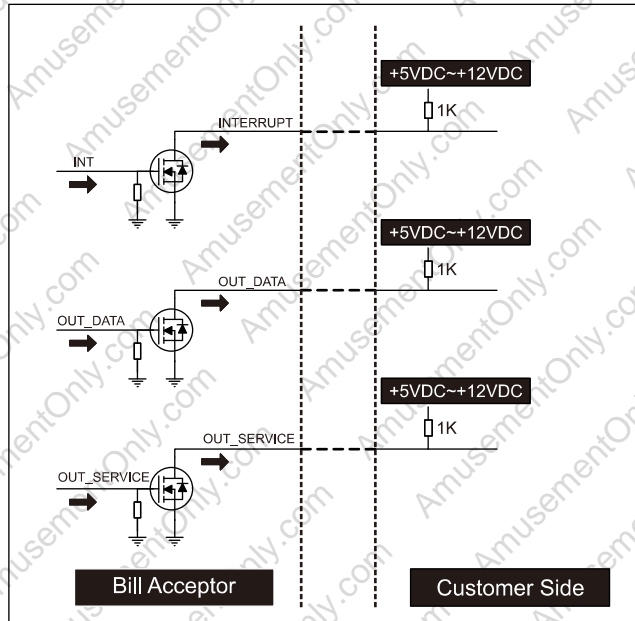

MDB Interface.

5-1-1 FIG.05

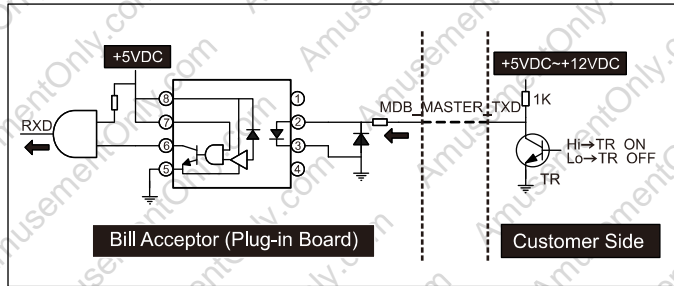
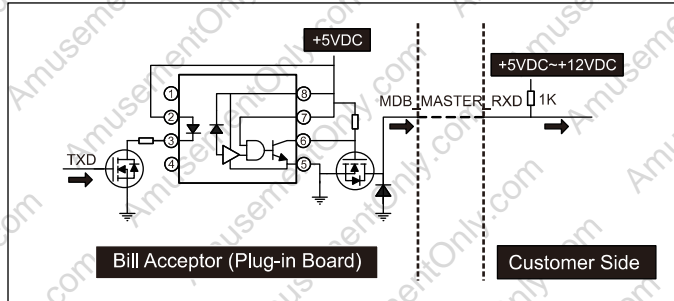

5-2. DIP Switch Setting

There are two serial DIP switches which are located on the side of TAO-A/V I(as FIG.01). According to different currencies which are used by users, DIP switch settings could be varied to fit users' needs. Besides, there's also a serial DIP switches on CPU board inside of TAO-A/V I for interface settings(as FIG.02). Please refer to "TAO-A/V DIP Switch Setting" Guide in the package for more details.

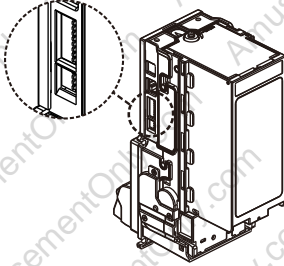

5-2 FIG.01

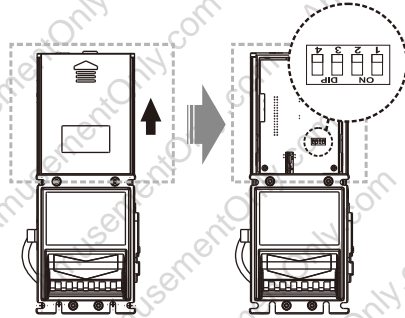

5-2 FIG.02

5-3. Software Download and Upgrade

To download and upgrade the software to TAO-A/V I, the programmer (FP-004) is needed. Please contact ICT to purchase FP-004 and refer to FP-004 user guide for software download and upgrade information.

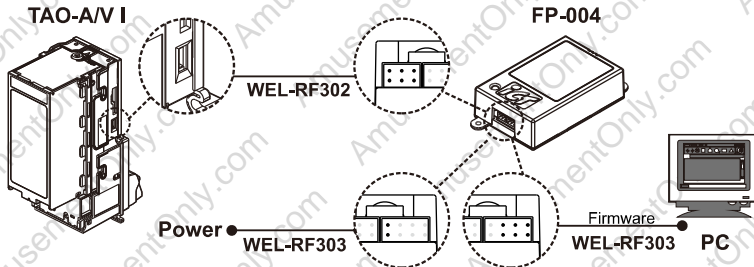

Power must be applied to Bill Acceptor after connecting.

6. Maintenance

To make sure the bill acceptor always works smoothly, please clean the internal parts regularly.

To clean the internal parts:

1. Press the buttons on the sides of bill path and pull the unit out.

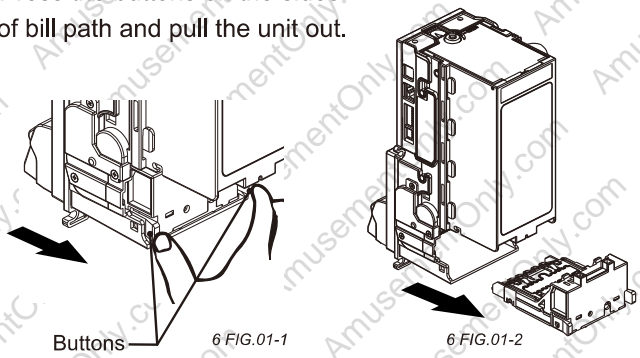

2. Use a soft, dry cloth, or towel to clean the bill path and sensors.

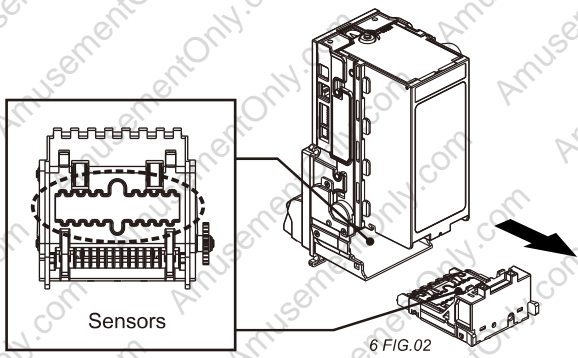

	Maintenance Notice	
	<i>(Any improper maintenance will result invalid warranty.)</i>	
	Recommended	Mild, non-abrasive, soap water.
	DO NOT USE	Organic solvent , Alcohol, Volatile liquid.

7. Troubleshooting

7-1. Bezel LED Errors

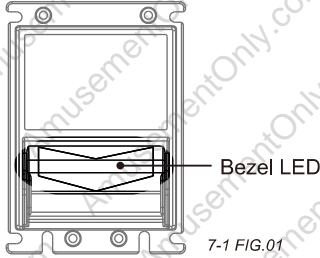

7-1 TABLE 01

LED Flashes		Status	Correct Actions
Red	Green		
	1	White Card Calibration	Please calibrate with ICT white calibration card.
1		Bill jammed.	Remove the bill box by sliding the top button and the bill path (refer to page 30), and then remove the jammed bill.
2		Disable.	Inspect the right DIP switch setting.
3		Recognition sensor module error.	Inspect the foreign objects on sensor or bill path and clean.
3+2		Hook sensor error.	Inspect the foreign objects on security hook and clean.
3+4		Out sensor error. (as FIG.02)	Inspect the foreign objects on sensor or bill path and clean.
4		Anti-string sensor error or a stringing attempt has detected.	Inspect the foreign objects on sensor or bill path and clean.
5		Bill box has been removed.	Replace the bill box.
6		Stacker error or stacker full.	Empty the bill box.
7		Motor error.	Inspect the foreign objects on bill path and clean.

7-2. Back LED Errors

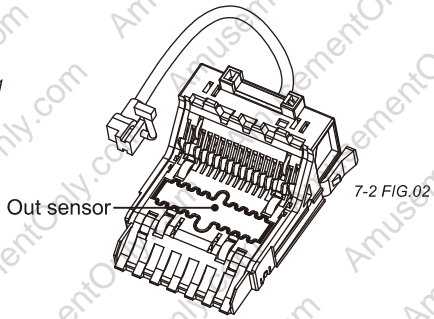
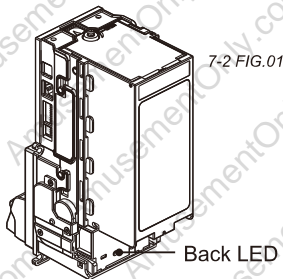

7-2 TABLE 01

LED Flashes	Status	Corrective Actions
Green		
1	White Card Calibration	Please calibrate with ICT white calibration card.
1	Bill jammed.	Remove the bill box by sliding the top button and the bill path (refer to page 30), and then remove the jammed bill.
2	Disable.	Inspect the right DIP switch setting.
3	Recognition sensor module error.	Inspect the foreign objects on sensor or bill path and clean.
3+2	Hook sensor error.	Inspect the foreign objects on security hook and clean.
3+4	Out sensor error. (as FIG.02)	Inspect the foreign objects on sensor or bill path and clean.
4	Anti-string sensor error or a stringing attempt has detected.	Inspect the foreign objects on sensor or bill path and clean.
5	Bill box has been removed.	Replace the bill box.
6	Stacker error or stacker full.	Empty the bill box.
7	Motor error.	Inspect the foreign objects on bill path and clean.



If the error can not be solved after corrective actions or happen again, please contact ICT for technical support.

◆ TAO-A/V I-P2/P5

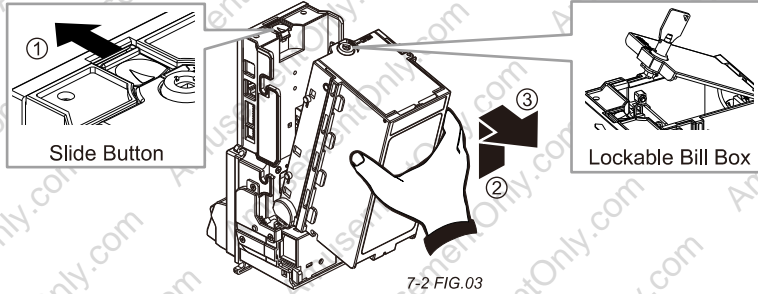

◆ TAO-A/V I-P10

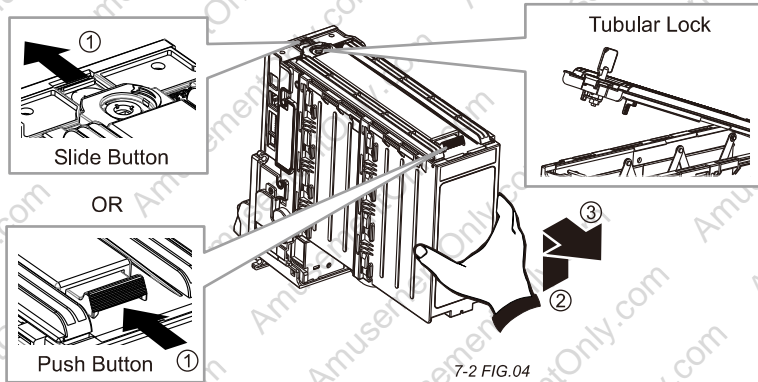



Taiwan

International Currency Technologies Corporation

No.28, Ln. 15, Sec. 6, Minquan E. Rd., Neihu Dist., Taipei City 114, Taiwan

sales@ictgroup.com.tw (For Sales)

fae@ictgroup.com.tw (For Customer Service)

Website: www.ictgroup.com.tw

