



SCA2

Series

Coin Acceptor

Installation Guide



Use of Materials Limitations

International Currency Technologies Corporation (ICT) all rights reserved.

All materials contained are the copyrighted property of ICT.

All trademarks, service marks, and trade names are proprietary to ICT.

ICT reserves the right at all times to disclose or to modify any information as ICT deems necessary to satisfy any applicable law, regulation, legal process or governmental request, or to edit, refuse to post or to remove any information or materials, in whole or in part, in ICT's sole discretion.

Contents

| | |
|--|----|
| 1. Introduction | |
| 1-1. Overview..... | 2 |
| 1-2. Features..... | 2 |
| 2. Specifications..... | 2 |
| 3. Packing List..... | 3 |
| 4. Dimension..... | 4 |
| 5. Installation | |
| 5-1. How to Install SCA2 in the machine..... | 6 |
| 5-1-1. Top Entry, Bottom Reject..... | 6 |
| 5-1-2. Front Entry, Front Reject..... | 7 |
| 5-2. Connector & PIN Assignment..... | 9 |
| 5-2-1. Connector..... | 9 |
| 5-2-2. PIN Assignment..... | 10 |
| 5-3. Harness Application..... | 12 |
| 5-4. I/O Circuits..... | 17 |
| 5-5. DIP Switch Setting..... | 20 |
| 6. Maintenance..... | 21 |
| 7. Troubleshooting..... | 23 |
| 8. Coin Sorter for SCA2 Top Entry(Optional)..... | 24 |

1. Introduction

1-1. Overview

SCA2 is designed as a reliable coin acceptor which is able to work steadily for high-security with acceptance rate 96% or greater and high accepting speed to provide you the most convenient service.

1-2. Features

- 8 channels available at once.
- Mechanical anti-string function.
- High acceptance rate 96% or greater.
- High accepting speed up to 2 coins per second.
- Equipped with the advanced anti-counterfeit technology.

2. Specifications

General

| | |
|------------------------|--|
| Coin Parameters | Diameter : 17~28mm Thickness: 1.5~2.4mm |
| Accepting Speed | <Pulse> 2 coins / 1 sec <Parallel> 2 coins / 1 sec <RS232> 2 coins / 1 sec |

| | |
|------------------------|------------------------|
| Acceptance Rate | 96% or greater |
| Interface | Parallel, Pulse, RS232 |

Electrical

| | |
|--------------------------|--|
| Power Source | +10V~16V DC |
| Power Consumption | Standby: 0.1A (1.2W) Operation: 0.4A (4.8W) Maximum: 0.5A (6W) |

| | |
|------------------------------|---|
| Operation Environment | Operation Temperature: -10°C~55°C (Temperature Change: Max.0.2°C/min) Storage Temperature: -25°C~70°C Humidity: 30%~85%RH(no condensation) |
|------------------------------|---|

Mechanical

| | |
|--------------------------|-------------------------------|
| Outline Dimension | Refer to Page.4 & 5 |
| Installation | Vertical, Max. Deviation: ±2° |
| Weight | Approx. 0.25kg (Net Weight) |

3. Packing List

| | |
|------------------|--|
| Main | SCA2 Coin Acceptor |
| Accessory | Harness: Refer to Page.12 SCA2 Installation Guide |

4. Dimension

Top Entry, Bottom Reject

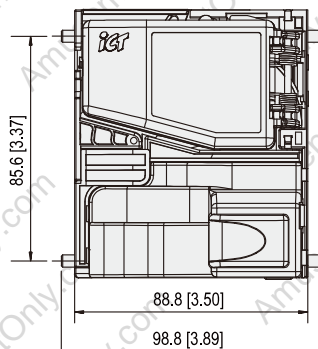
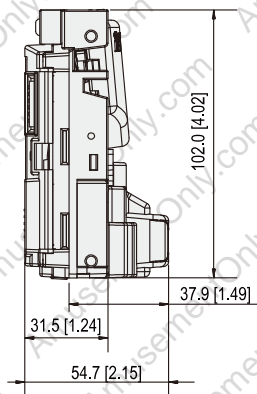
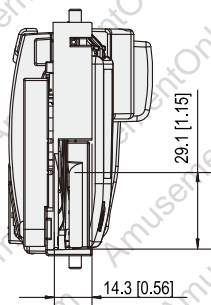

Unit : mm [inch]

4 FIG.01

Front Entry, Front Reject

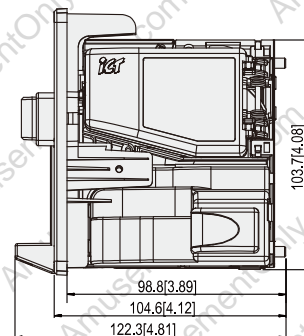
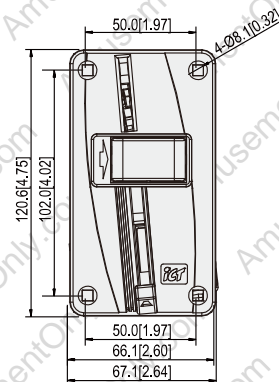
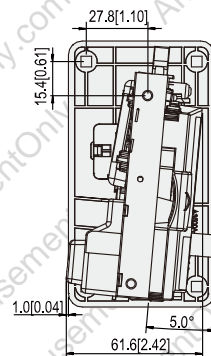

Unit : mm [inch]

4 FIG.02

5. Installation

5-1. How to install SCA2 in the machine?

5-1-1. Top Entry, Bottom Reject

To install SCA2 in the machine, we suggest you to hang SCA2 in the machine (as FIG.01-1) using the lateral mounting studs (as FIG.01-2).

5-1-1 FIG.01-1

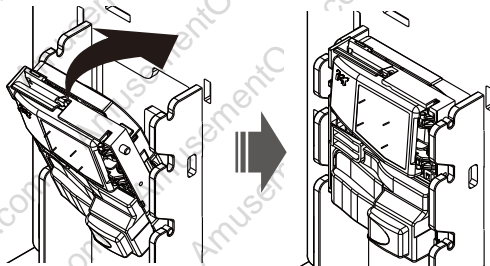

5-1-1 FIG.01-2
Mounting studs

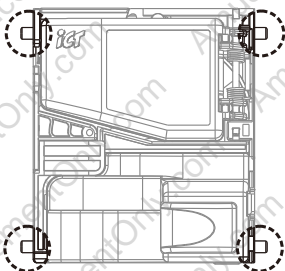

5-1-2. Front Entry, Front Reject

Please follow the steps as below.

1. Use four screws to fix bezel on the machine.

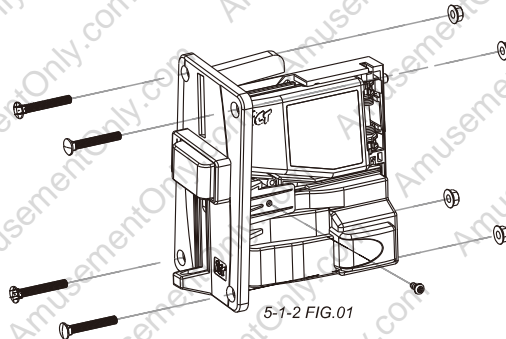

5-1-2 FIG.01

2. Fix main base on bezel by mounting clips.

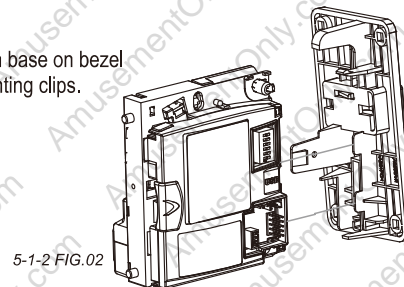

5-1-2 FIG.02

 The deviation of SCA2 should be less than 2°.

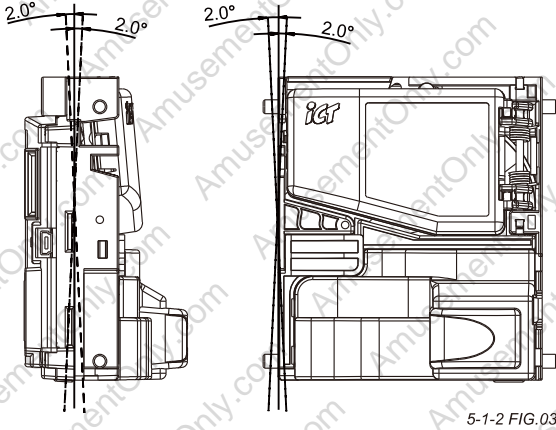

5-2. Connector & PIN Assignment

5-2-1. Connector

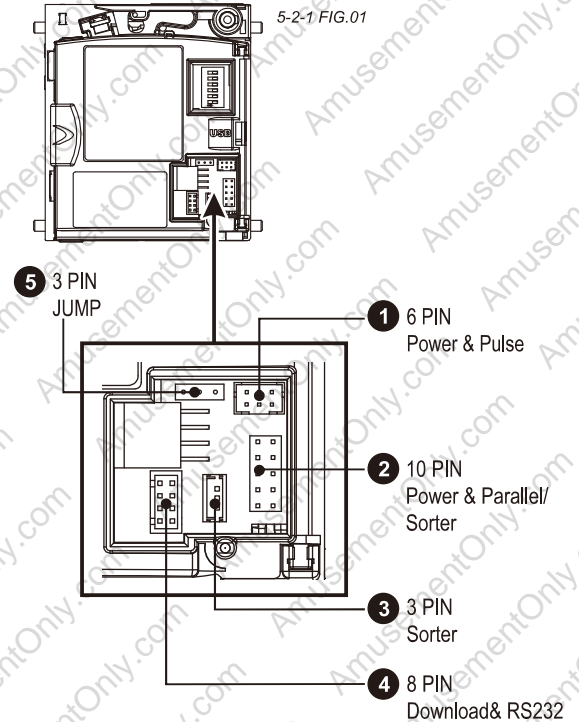

5-2-2. PIN Assignment

(1) 6 PIN Power & Pulse

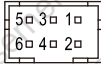

- PIN 1- +10~16V DC VIN
- PIN 2- GND
- PIN 3- INHIBIT
- PIN 4- X
- PIN 5- IMPULSE
- PIN 6- X

(2) 10 PIN Power & Parallel/Sorter

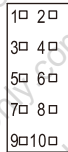

Power & Parallel

- | | |
|-----------------------|--------------------|
| PIN 1- I_GND | PIN 6- INHIBIT |
| PIN 2- +10~16V DC VIN | PIN 7- COIN_LINE1 |
| PIN 3- COIN_LINE5 | PIN 8- COIN_LINE2 |
| PIN 4- COIN_LINE6 | PIN 9- COIN_LINE3 |
| PIN 5- RETURN | PIN 10- COIN_LINE4 |

10 PIN Sorter

- | | |
|-----------------------|-------------|
| PIN 1- I_GND | PIN 6- N/A |
| PIN 2- +10~16V DC VIN | PIN 7- N/A |
| PIN 3- COIN_LINE5 | PIN 8- N/A |
| PIN 4- COIN_LINE6 | PIN 9- N/A |
| PIN 5- N/A | PIN 10- N/A |

(3) 3 PIN Sorter



- PIN 1- SORTER_SOL1
- PIN 2- SORTER_SOL2
- PIN 3- SORTER

(4) 8 PIN Download & RS232



- | | |
|----------------|---------------|
| PIN 1- GND | PIN 5- /RESET |
| PIN 2- TX22 | PIN 6- +5V |
| PIN 3- RX22 | PIN 7- RX11 |
| PIN 4- PROGRAM | PIN 8- Tx11 |

(5) 3 PIN JUMP INHIBIT



- Short PIN 1~2-Inhibit Normal High
- Short PIN 2~3-Inhibit Normal Low

Please contact ICT FAE for more details.

5-3. Harness Application

5-3 TABLE 01

| Interface | Used Voltage | Usage | Harness | Page |
|-----------|--------------|---------------------|---------------------|------|
| Pulse | 10V~16V DC | Power & *Data Comm. | WEL-RMS03 | 12 |
| | | Power & *Data Comm. | WEL-RMS02(Optional) | 13 |
| | | Extension Wire | CU-R961-1(Optional) | 14 |
| RS232 | 10V~16V DC | Power | WEL-RMS03 | 12 |
| | | *Data Comm. | WEL-R7U06-2 | 15 |
| Parallel | 12V DC | Power & *Data Comm. | IDC-RA10400 | 16 |

*Data Comm.: Data Communication.

5-3 FIG.01

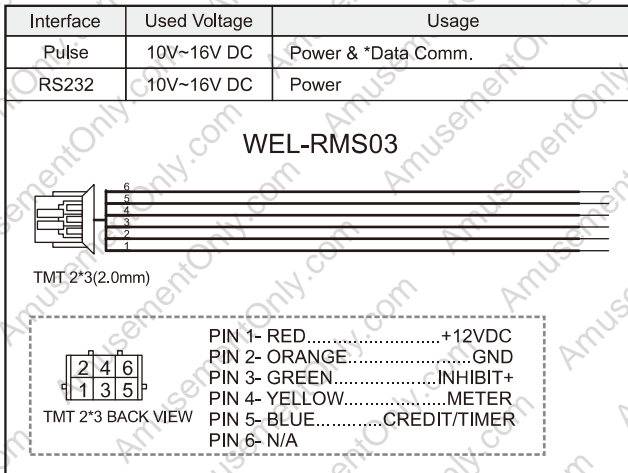

5-3 FIG.02

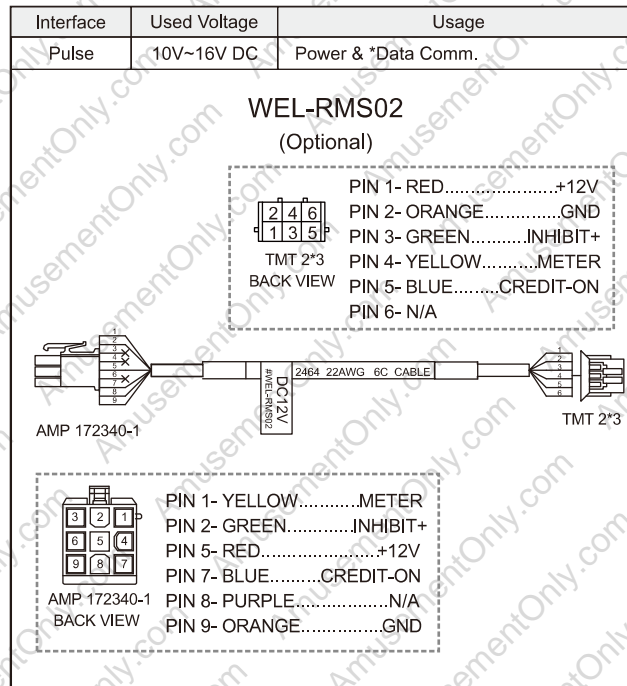

5-3 FIG.03

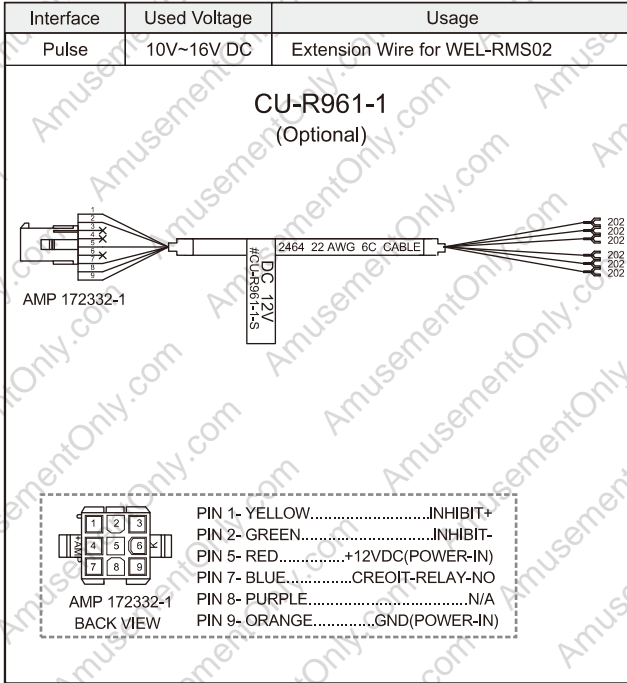

5-3 FIG.04

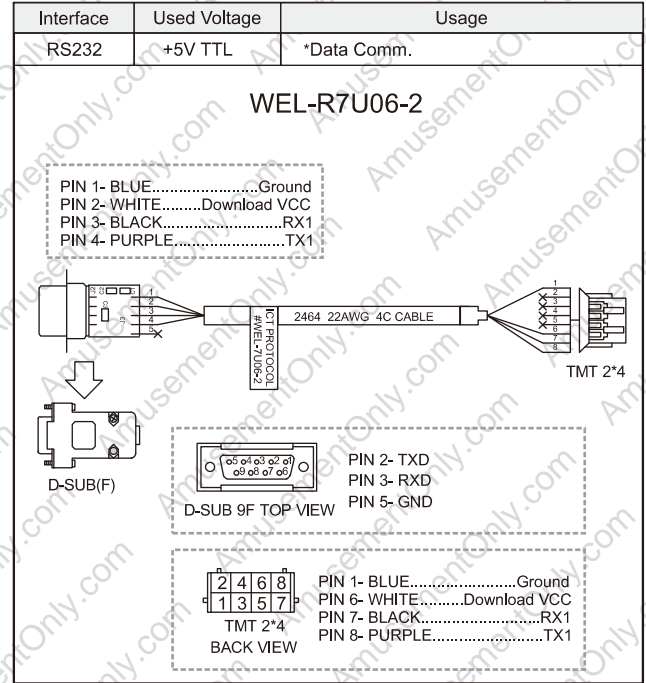

5-3 FIG.05

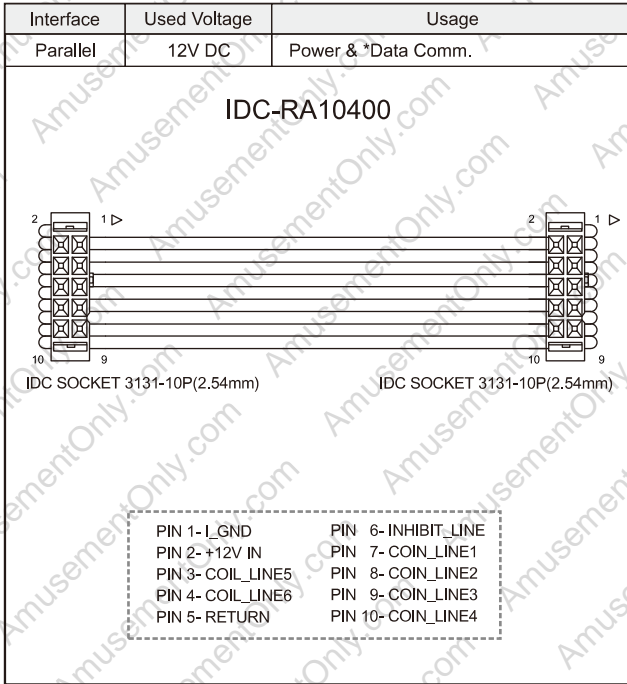

5-4. I/O Circuits

Parallel Interface

5-4 FIG.01

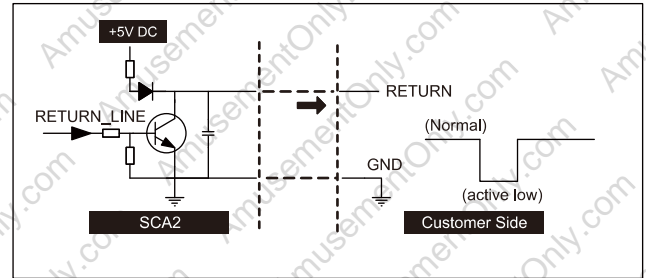
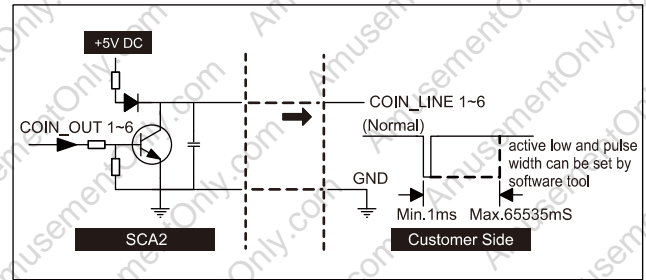

Pulse Interface

5-4 FIG.02

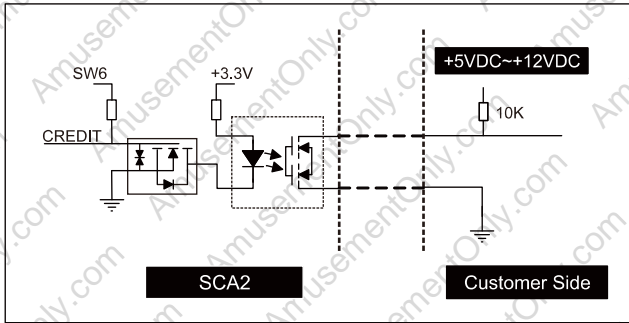

RS232 Interface

5-4 FIG.03

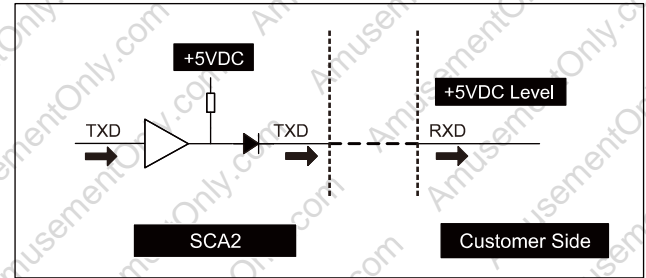

Short PIN 1~2-Inhibit Normal High
Short PIN 2~3- Inhibit Normal Low

+5VDC~+12VDC

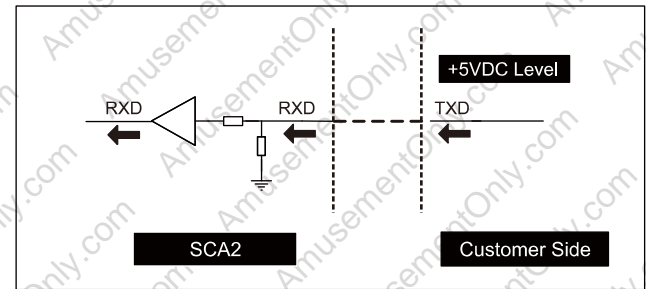
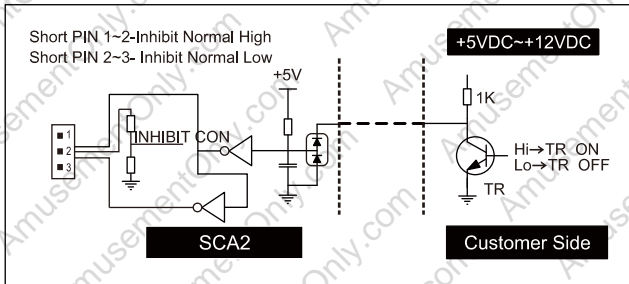

5-5. DIP Switch Setting

The DIP switches are located on the side of SCA2 which are designed for coin channel setting, users can select coin accepting or reject by setup the DIP switches(as FIG.01-1).

For DIP switch setting which fits your need, please refer to the sticker(as FIG.01-2) next to DIP switches on SCA2.

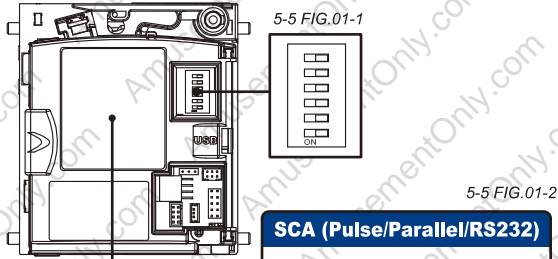

| SCA (Pulse/Parallel/RS232) | | | | | |
|----------------------------|-----|-----|---------|-----|-----|
| FUNCTION | SW1 | SW2 | SW3-SW5 | SW6 | |
| Pulse(25ms) | OFF | OFF | | | |
| Pulse(45ms) | ON | OFF | | | *1 |
| Pulse(60ms) | OFF | ON | | | |
| Pulse(100ms) | ON | ON | | | |
| Normal Open | | | | | ON |
| Normal Close | | | | | OFF |

*1: Please refer to "DIP Switches Setting"

Part Number:H8330C-R

6. Maintenance

To make sure SCA2 coin acceptor always works smoothly, please clean the internal sensors regularly.

To clean the internal sensors:

1. Open cover plate of upper base, hold it to open, and then use a soft, dry cloth, or towel to clean sensors(as FIG.01-1) .

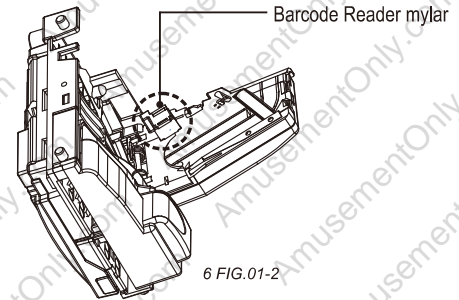
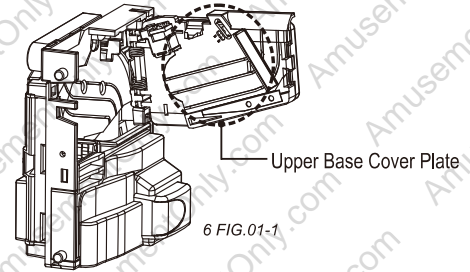

2. Release the mounting clip and remove the Solenoid Valve Mount, and then clean the internal parts with a soft, dry cloth, or towel (as FIG.02).

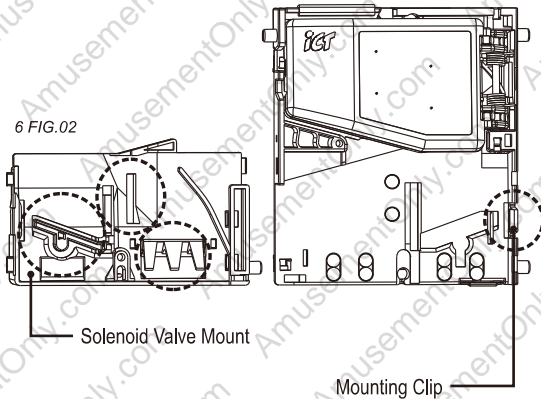

| | | |
|-------------------|---|--|
| | Maintenance Notice | |
| | <i>(Any improper maintenance will invalidate the warranty.)</i> | |
| | Recommended | Mild, non-abrasive, soap water. |
| DO NOT USE | Organic solvent , Alcohol, Volatility liquid. | |

7. Troubleshooting

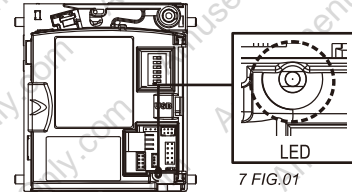

7 TABLE 01

| LED Flashes | | | Status | Corrective Actions |
|-------------|---------|--------|--|---|
| Green | Orange | Red | | |
| ON | N/A | N/A | Power ON | N/A |
| N/A | ON | N/A | INHIBIT | N/A |
| N/A | Flashes | N/A | I/O Test Mode | N/A |
| N/A | N/A | 1 | First coil set error | Call ICT or agents for technical support. |
| N/A | N/A | 2 | Second coil set error | |
| N/A | N/A | 3 | Fish sensor error | Inspect for foreign objects in coin path and clean. |
| N/A | N/A | 4 | Drop sensor error | |
| N/A | N/A | 5 | Return sensor error | |
| N/A | N/A | 6 | IR sensor error | |
| N/A | N/A | 7 | Program error | Call ICT or agents for technical support. |
| N/A | N/A | 8 | ID Code error | |
| N/A | N/A | 9 | BarCode error | |
| N/A | N/A | Fast 2 | A Stringing attempt has been detected. | Inspect for foreign objects in coin path and clean. |



If the error cannot be solved after corrective actions or it recurs, please contact ICT for technical support.

8. Coin Sorter for SCA2 Top Entry (optional)

The coin sorter is designed for combining with SCA2 coin acceptor. It can sort up for four different coins at the same time while accepting multiple coins from SCA2.

For purchasing Coin Sorter for SCA2, please contact ICT.

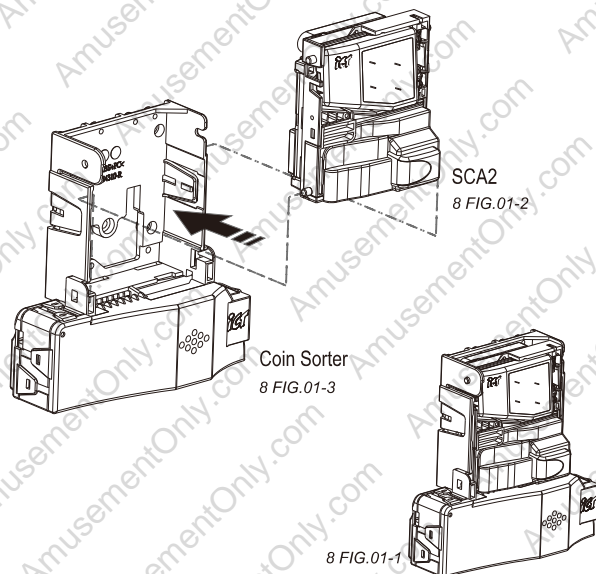

ict Taiwan

International Currency Technologies Corporation

No.28, Ln. 15, Sec. 6, Minquan E. Rd., Neihu Dist., Taipei City 114, Taiwan (R.O.C.)

sales@ictgroup.com.tw (For Sales)

rma@ictgroup.com.tw (For Customer Service)

Website: www.ictgroup.com.tw



SCA2 works with ICT coin sorter under 12V(10~16V) only.