



Bill Acceptor

S7A

Installation Guide

International Currency Technologies Corp.

Use of Materials Limitations

International Currency Technologies Corporation (ICT) all rights reserved.

All materials contained are the copyrighted property of ICT.

All trademarks, service marks, and trade names are proprietary to ICT.

ICT reserves the right at all times to disclose or to modify any information as ICT deems necessary to satisfy any applicable law, regulation, legal process or governmental request, or to edit, refuse to post or to remove any information or materials, in whole or in part, in ICT's sole discretion.

Contents

1. Introduction	
1-1. Overview	2
1-2. Features	2
2. Specifications	3
3. Packing List	4
4. Dimension	5
4-1. Bezel Style.....	6
5. Installation	
5-1. Harness Application	7
5-1-1. I/O Circuit	16
5-2. DIP Switch Setting	20
5-3. Software Download and Upgrade	21
6. Maintenance	22
7. Troubleshooting	
7-1. Bezel LED Errors	23
7-2. Back LED Errors	24

1. Introduction

1-1. Overview

S7A Series is a bill acceptor which features not only high-security module with bill box but also outstanding recognition, acceptance rate up to 96% or even greater.

1-2. Features

- Power saving function.
- Auto-calibrating.
- Easy maintenance.
- Detective bill-full mechanism.
- MDB-online / IrDA firmware upgrade.
- Life cycle 300,000 times(Approx. 2 years).
- Advanced optical/mechanical anti-fishing structure.

2. Specifications

General

Acceptance Rate 96% or greater

Note: The incomplete bills such as extremely dirty, wet, broken or wrinkled ones are excluded.

Bill Insertion Four way acceptable

Transaction Speed Approx. 3s to stack

Interface Pulse
MDB
RS232 (ICT Protocol)
ccTalk (adaptor board)
Parallel A3 (adaptor board)

Electrical

Power Source 10V DC~42.5V DC

Power Consumption Normal Mode_
Standby : 0.23A, 2.8W
Operation: 1.5A, 18W
Maximum: 2A, 24W
Power Saving Mode_
Mode 1: 50 μ A
Mode 2: 15 μ A

Operation Environment Operating Temperature: -15°C~60°C
Storage Temperature: -30°C~70°C
Humidity: 0%~85%RH(no condensation)

Mechanical

Bill Capacity	Approx. 100 bills 200 bills 300 bills 400 bills
Weight	Approx. 1.5kg
Bill Accepted Width	62~72mm
Installation	Indoor & Outdoor

3. Packing List

Main

Bill Acceptor

Accessory

Harnesses: Refer to 5-1 external label: for sticking onto the surface of vending machine to easily align the €5 at the bezel of S7A.

4. Dimension

STD Bezel

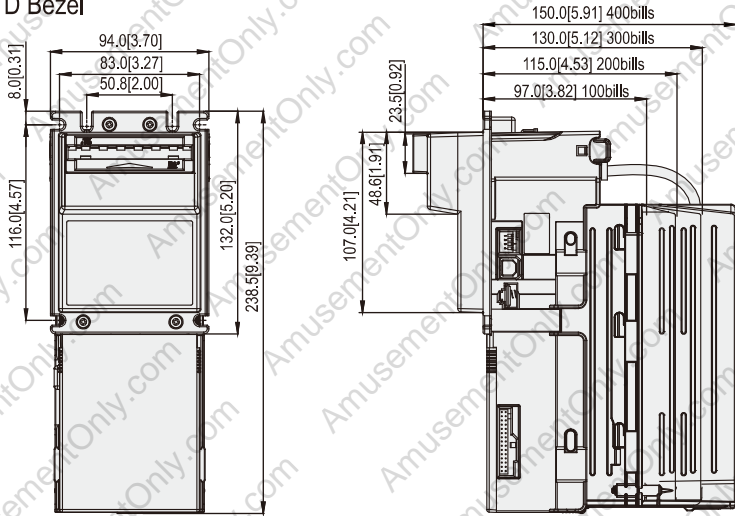

4 FIG.01

Unit : mm [inch]

TOB Bezel

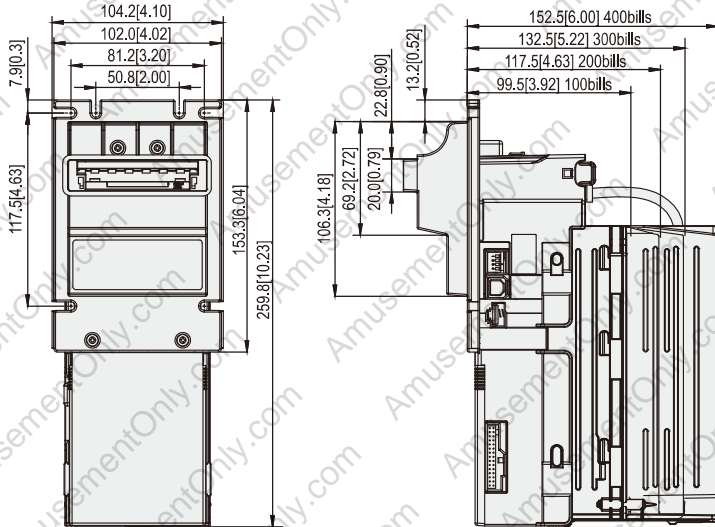

4 FIG.02

Unit : mm [inch]

4-1. Bezel Style

Choose S7A with the suitable bezel to fit the cabinet.

STD Bezel

Up-Stack

Down-Stack

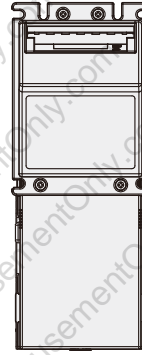
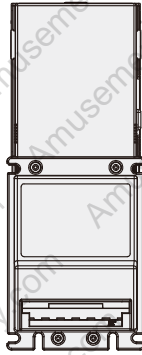

TOB Bezel

Up-Stack

Down-Stack

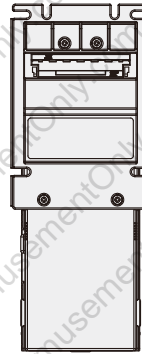
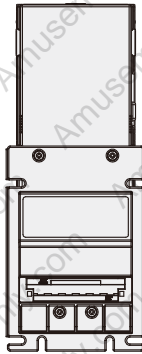

5. Installation

5-1. Harness Application

5-1 TABLE 01

Interface	Used Voltage	Mode	Usage	Harness	Page
Pulse	10~24V DC	Normal	Power & *Data Comm.	WEL-RV701	8
			Extension Wire	CU-R961-1	12
	24VAC	Normal	Power & *Data Comm.	WEL-RV703	10
			Extension Wire	WEL-RV702	9
10~24VDC	Sleep	Power & *Data Comm.	WEL-RV707	11	
RS232 (ICT Protocol)	10~24V DC	Normal	Power & *Data Comm.	WEL-RV701	8
			Extension Wire	CU-R961-1	12
			*Data Comm.	WEL-RV706-1 or 2-BA-RV706	13
	10~24V DC	Sleep	Power & *Data Comm.	WEL-RV707	11
MDB	10~24V DC	Sleep	Power & *Data Comm.	WEL-RS7P02	14
	34V DC	Normal		WEL-RM006	15
Parallel A3	24VAC	Normal	Power & *Data Comm.	5RBG-AA203L1-xx	16
ccTalk	10~24VDC	Normal	Power & *Data Comm.	**5RBG-AA248M2-xx	

*Data Comm.: Data Communication.

**5RBG-AA248M2-xx: Please refer to ccTalk Installation Guide.

5-1 FIG.01

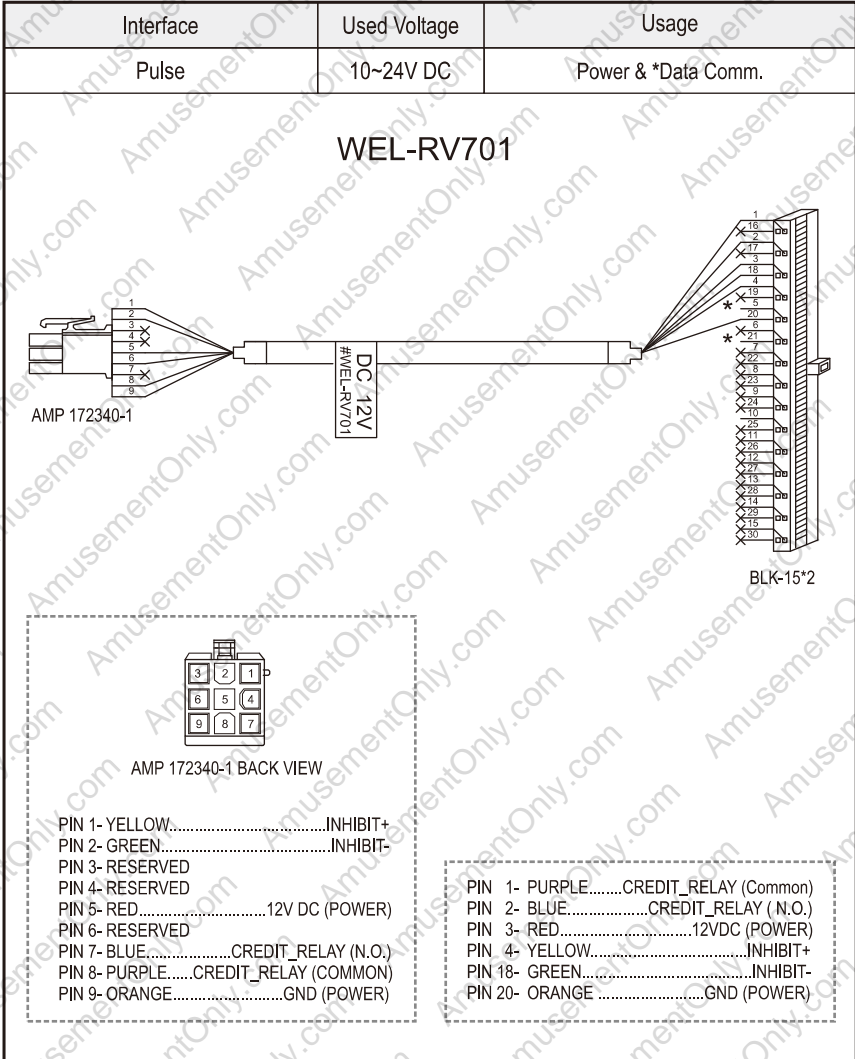

5-1 FIG.02

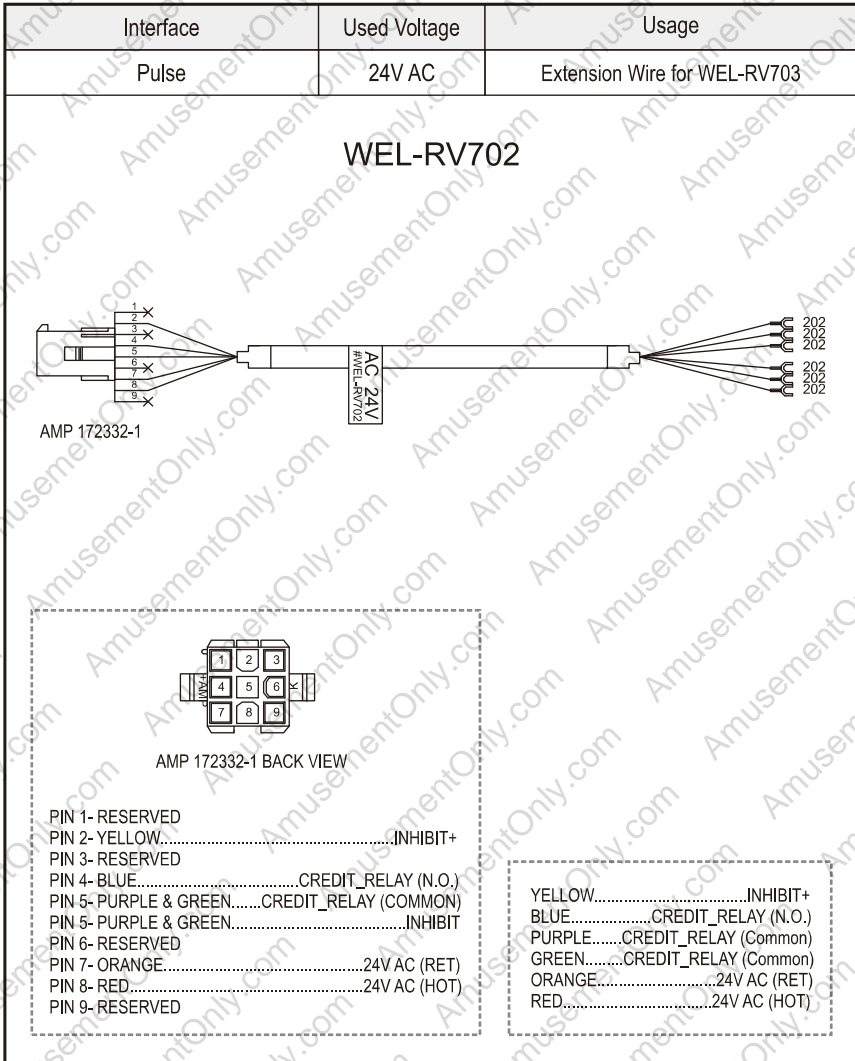

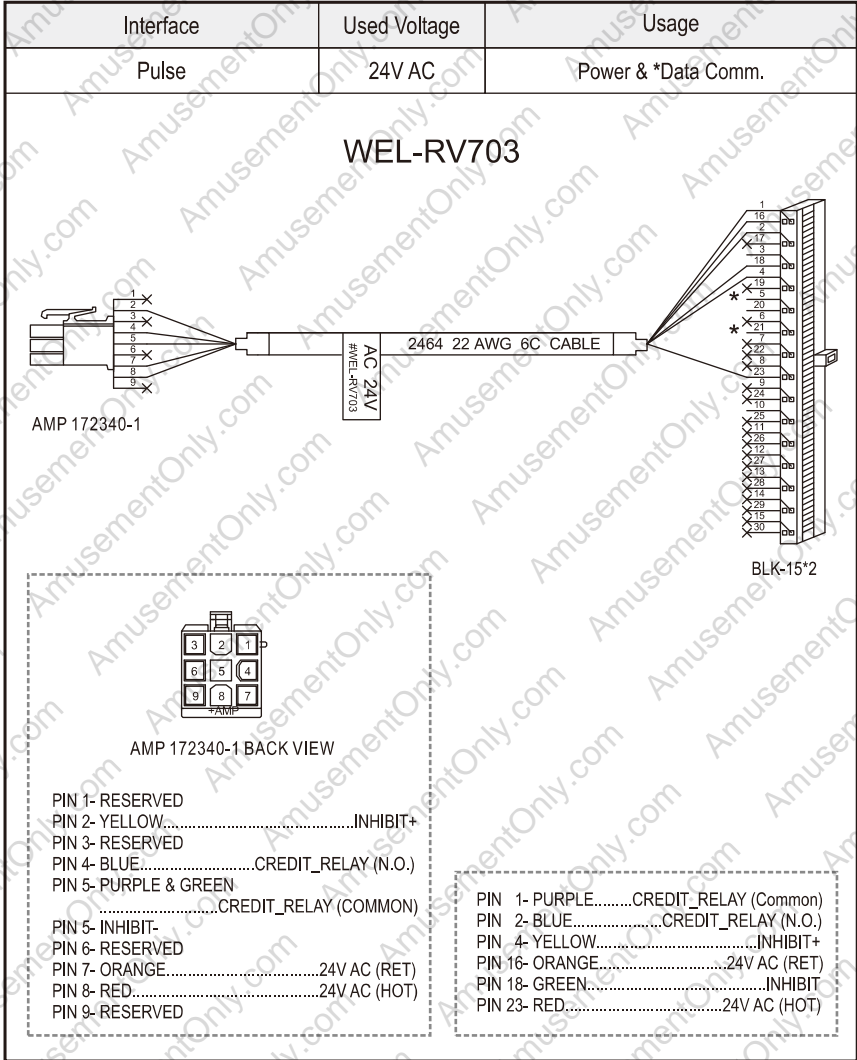

5-1 FIG.04

Interface	Used Voltage	Usage
Pulse	10~24V DC	Power & Data Comm.
RS232(ICT Protocol)	10~24V DC	Power & Data Comm.

WEL-RV707

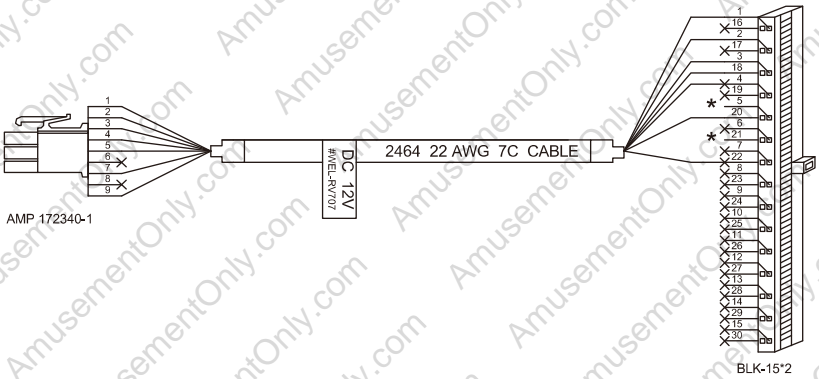

AMP 172340-1

BLK-15*2



AMP 172340-1 BACK VIEW

- PIN 1- YELLOW.....INHIBIT+
- PIN 2- GREEN.....INHIBIT-
- PIN 3- BLACK.....WAKE_UP_NO.
- PIN 4- PURPLE.....WAKE_UP_COM.
- PIN 5- RED.....12V DC (POWER)
- PIN 6- RESERVED
- PIN 7- BLUE.....CREDIT
- PIN 8- RESERVED
- PIN 9- BROWN.....GND (POWER)

- PIN 1- PURPLE.....AKE_UP_COM.
- PIN 2- BLACK.....WAKE_UP_NO.
- PIN 3- RED.....12V DC (POWER)
- PIN 4- YELLOW.....INHIBIT+
- PIN 18- GREEN.....INHIBIT-
- PIN 20- BROWN.....GND (POWER)
- PIN 22- BLUE.....CREDIT

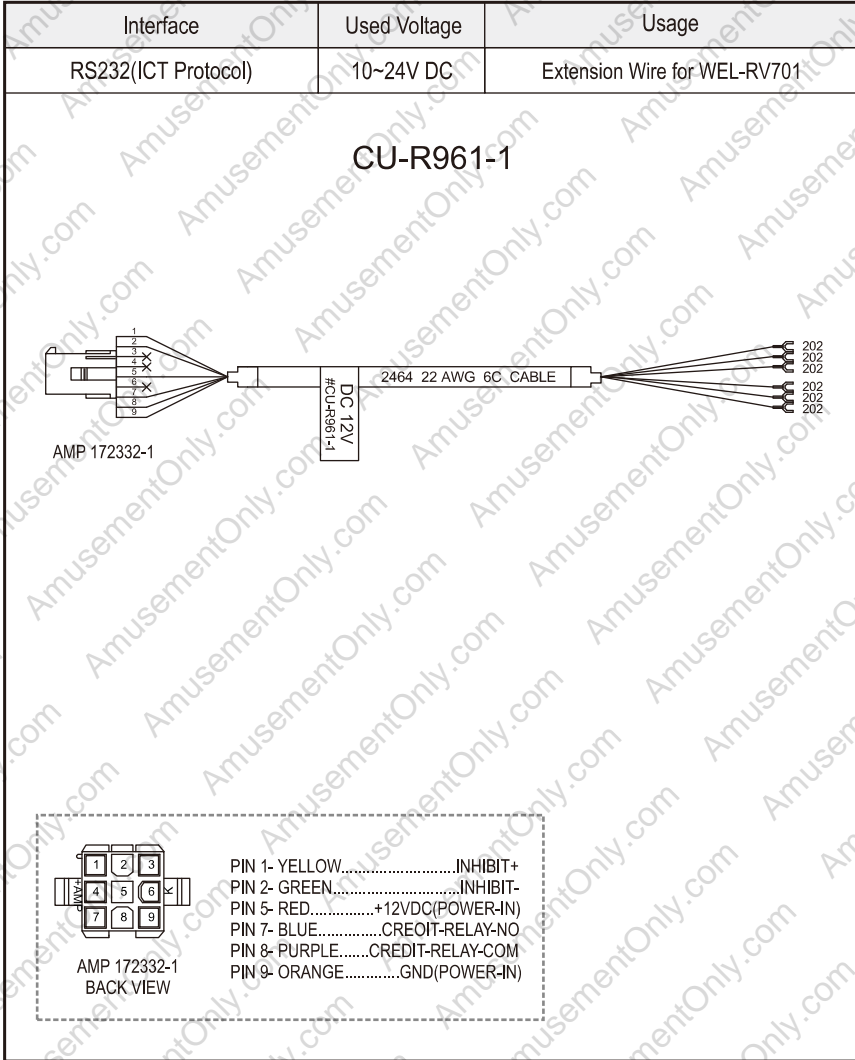

5-1 FIG.06

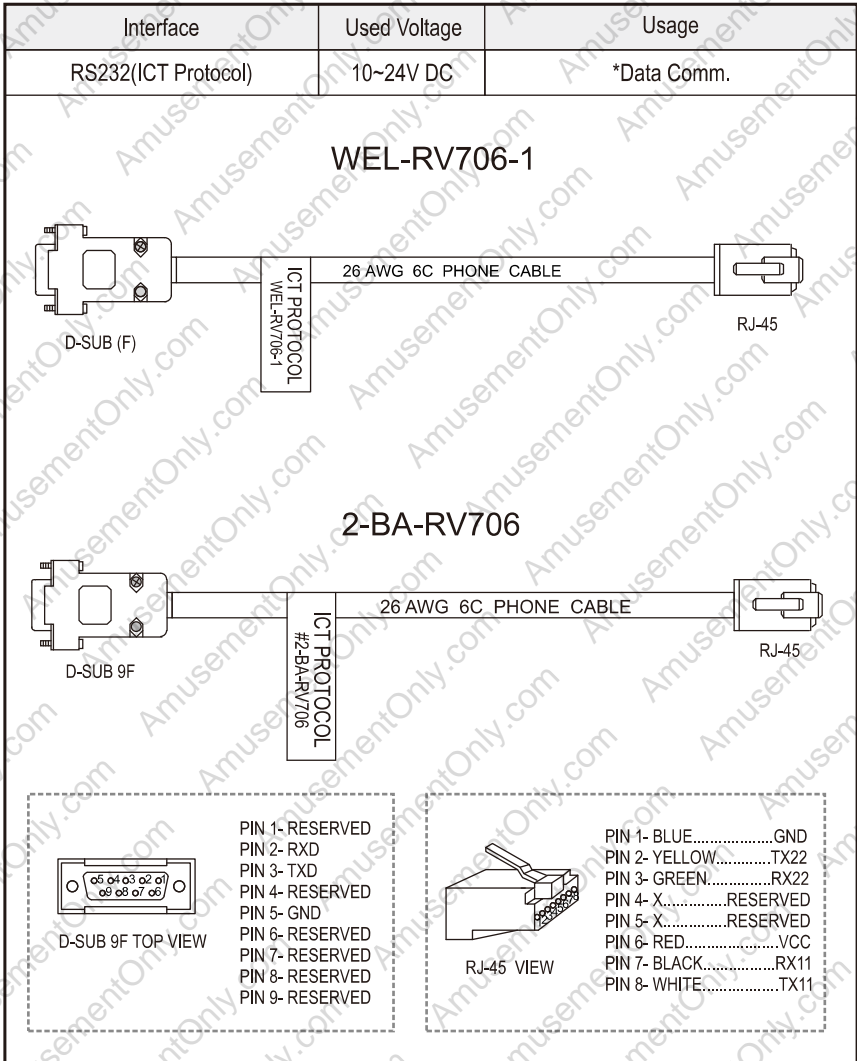

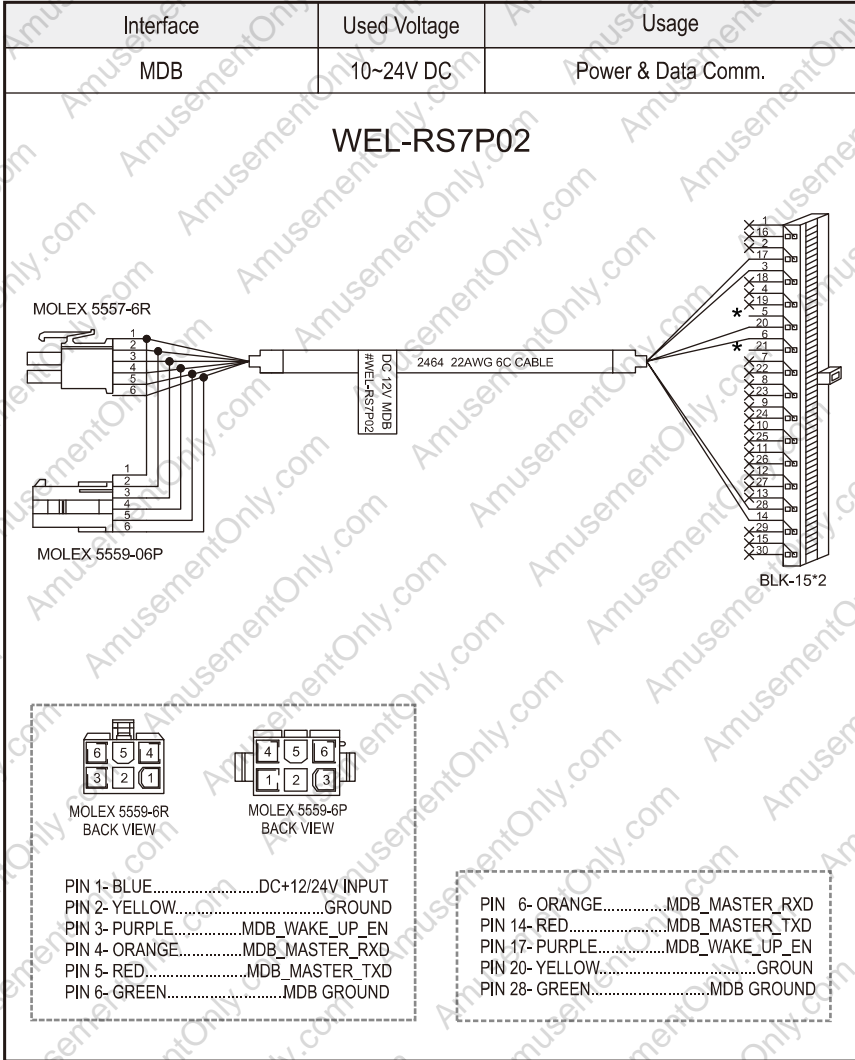

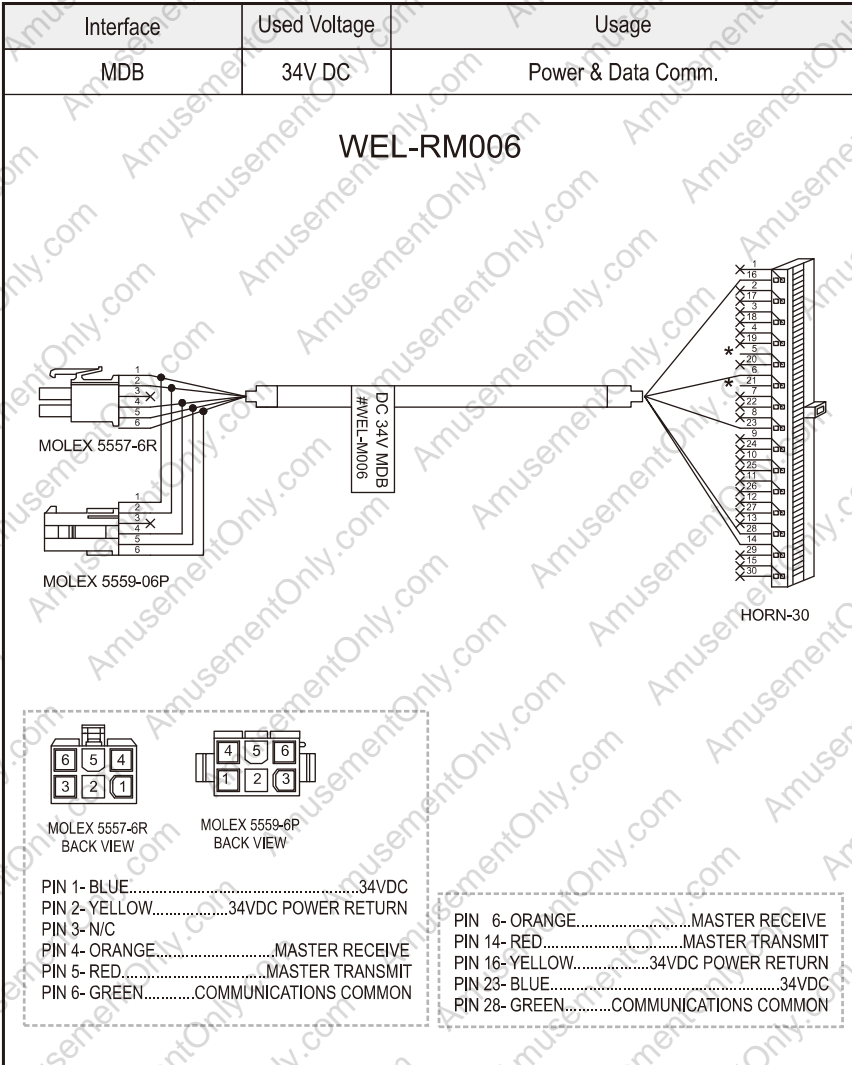

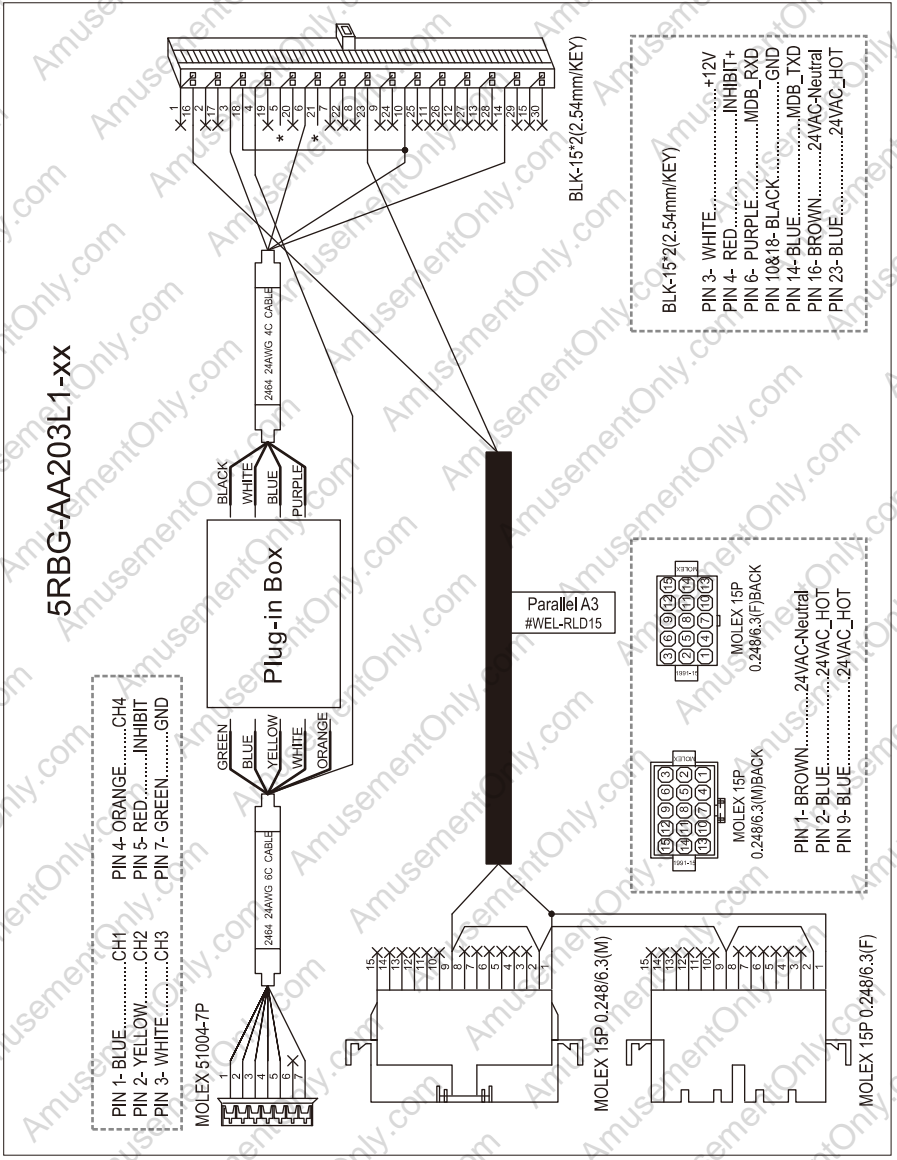

5-1-1. I/O Circuit

Pulse Interface.

5-1-1 FIG.01

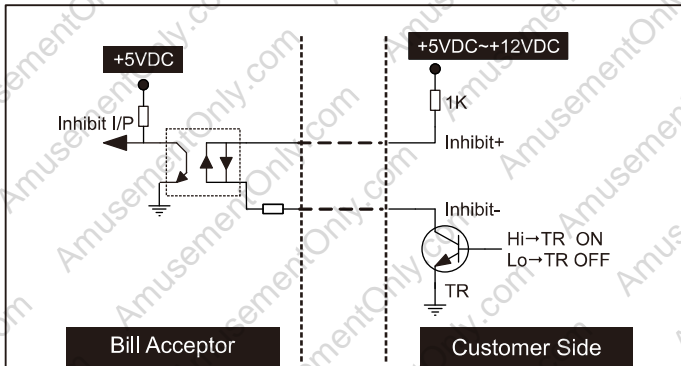
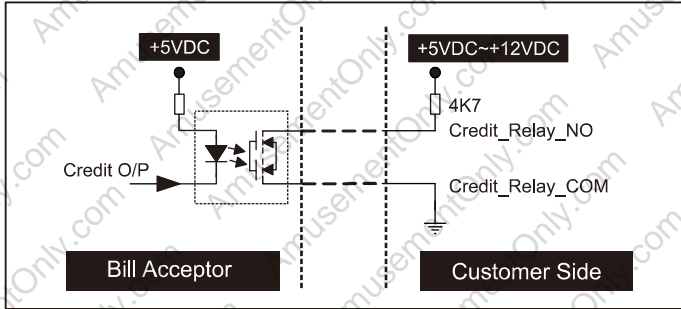

BA Status	DIP SW Setting		Control Signal
Inhibit	Inhibit Active	Low	Low
		High	High
Enable	Inhibit Active	Low	High
		High	Low

ICT-Protocol Interface.

5-1-1 FIG.02

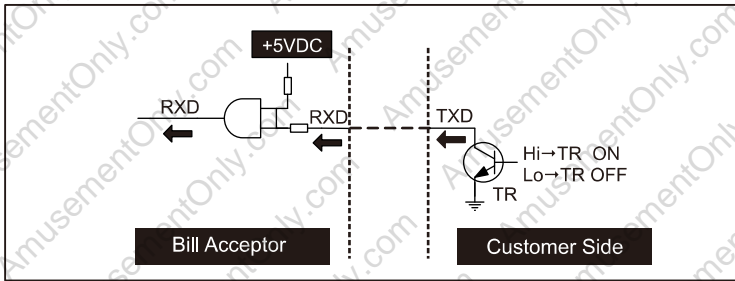
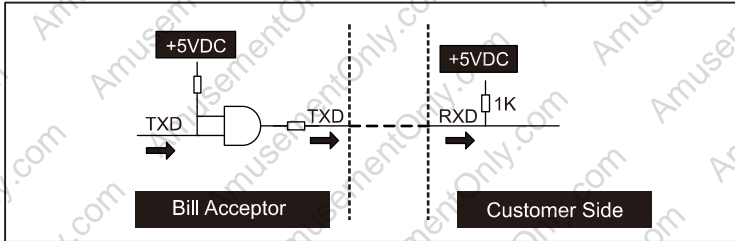

Parallel A3 Interface

5-1-1 FIG.03

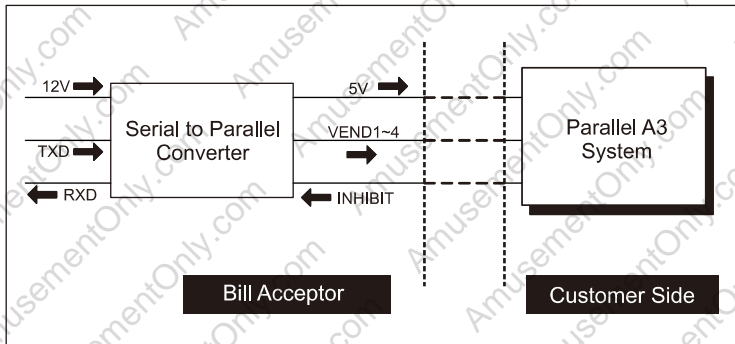

MDB Interface.

5-1-1 FIG.04

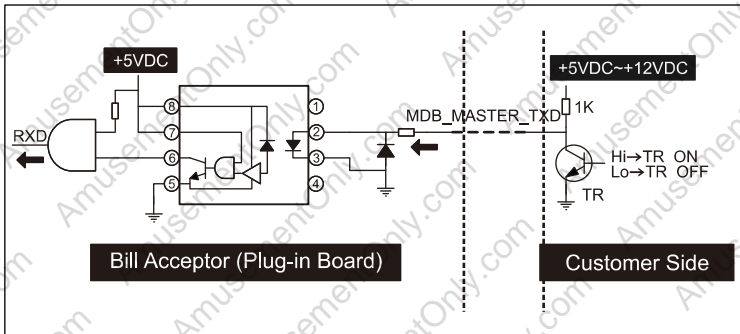
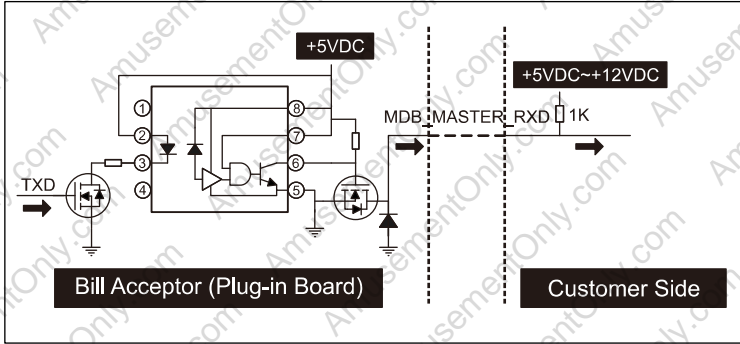

5-2. DIP Switch Setting

There are two serial DIP switches which are located on the side of S7A series (as 5-2 FIG.01). According to different currencies which are used by users, DIP switch settings could be varied to fit users' need. Besides, there's also a serial DIP switches on CPU board inside of S7A series for interface settings (as 5-2 FIG.02). Please refer to "S7A series DIP Switch Setting Guide" in the package for more detail.

5-2 FIG.01

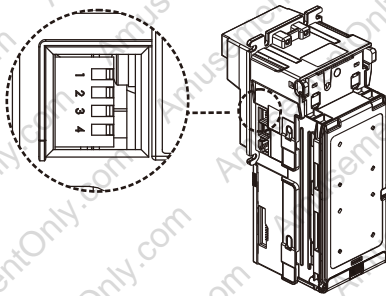

5-2 FIG.02

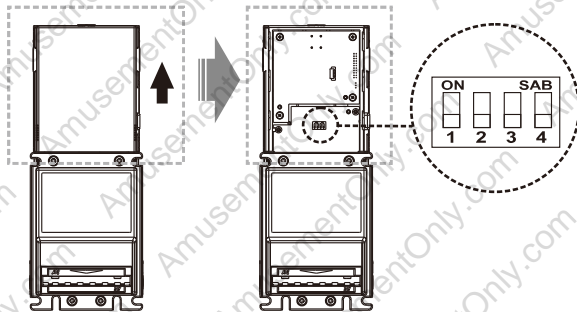

5-3. Firmware Download and Upgrade

To download and upgrade the software to S7A, the programmer(FP-004) is needed. Please contact ICT to purchase FP-004 and refer to the FP-004 user guide for software download and upgrade information.

Step 1.

Switch 4-1 into "ON" to wake S7A up.
(Switch and download 4-1 back "OFF" after download.)

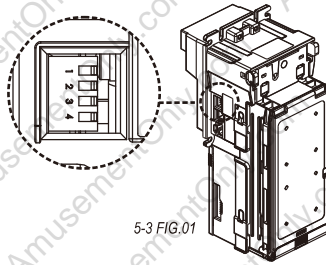

Step 2. Connection

Power must be applied to Bill Acceptor after connecting.

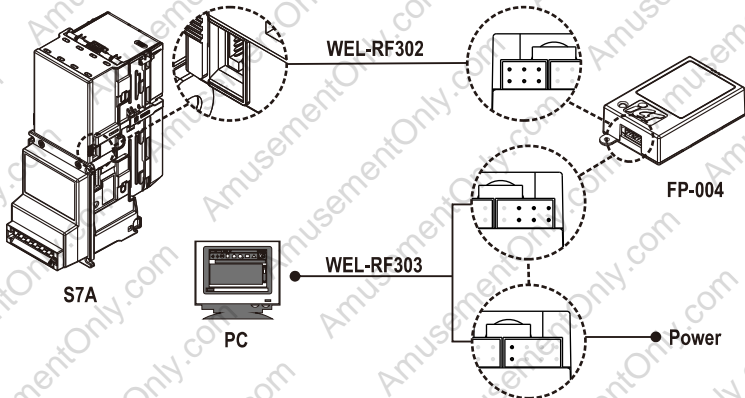

6. Maintenance

To make sure the bill acceptor always works smoothly, please clean the internal parts regularly.

To clean the internal parts:

1. Press the buttons on the sides of bill path and pull the unit out.

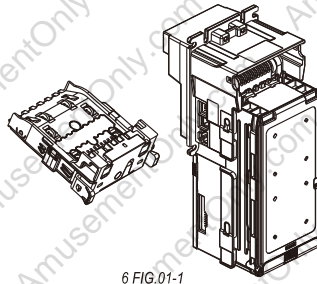
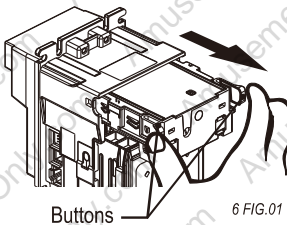

2. Use a soft, dry cloth or towel to clean the bill path and sensors.

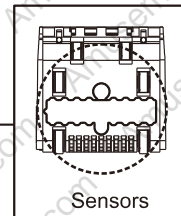
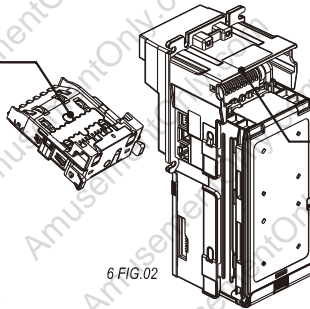
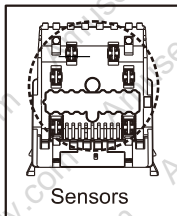

	Maintenance Notice	
	<i>(Any improper maintenance will result invalid warranty.)</i>	
	Recommended	Mild, non-abrasive, soap water.
	DO NOT USE	Organic solvent , Alcohol, Volatility liquid.

7. Troubleshooting

7-1. Bezel LED Errors

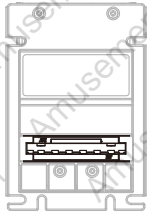

TOB
Bezel LED
7-1 FIG.01

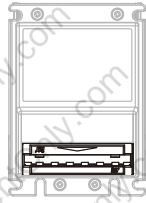

STD
Bezel LED
7-1 FIG.02

7-1 TABLE 01

LED Flashes	Status	Corrective Actions
Blue	Bill acceptor recognizes bill locates uncentrally.	Move bill to center position.

7-1 TABLE 01-1

LED Flashes		Status	Corrective Actions
Green	RED		
1		White Card Calibration	Please calibrate with ICT white calibration card.
	1	Bill jammed.	Remove the bill box by sliding the top button and the bill path(as 7-2 FIG.01), and then remove the jammed bill.
	2	Disable.	Inspect for right DIP switch setting.
	3	Recognition sensor module error.	Inspect for foreign objects on sensor or bill path and clean.
1	3	Optical anti fishing sensor module error	Remove LED housing: Inspect for foreign object and clean on Security hook.
	3+2	Hook sensor error.	Inspect for foreign objects on security hook and clean.
	3+4	Out sensor error.	Inspect for foreign objects on sensor or bill path and clean.
	4	Anti-string sensor error or a stringing attempt has detected.	Inspect for foreign objects on sensor or bill path and clean.
	5	Bill box has been removed.	Replace the bill box.
	6	Stacker error or stacker full.	Empty the bill box.
	7	Motor error.	Inspect for foreign objects on bill path and clean.

7-2. Back LED Errors

7-2 TABLE 01

LED Flashes	Status	Corrective Actions
RED		
1	White Card Calibration	Please calibrate with ICT white calibration card.
1	Bill jammed.	Remove the bill box by sliding the top button and the bill path(as 7-2 FIG.01), and then remove the jammed bill.
2	Disable.	Inspect for right DIP switch setting.
3	Recognition sensor module error.	Inspect for foreign objects on sensor or bill path and clean.
3	Optical anti fishing sensor module error	Remove LED housing: Inspect for foreign object and clean on Security hook.
3+2	Hook sensor error.	Inspect for foreign objects on security hook and clean.
3+4	Out sensor error.	Inspect for foreign objects on sensor or bill path and clean.
4	Anti-string sensor error or a stringing attempt has detected.	Inspect for foreign objects on sensor or bill path and clean.
5	Bill box has been removed.	Replace the bill box.
6	Stacker error or stacker full.	Empty the bill box.
7	Motor error.	Inspect for foreign objects on bill path and clean.

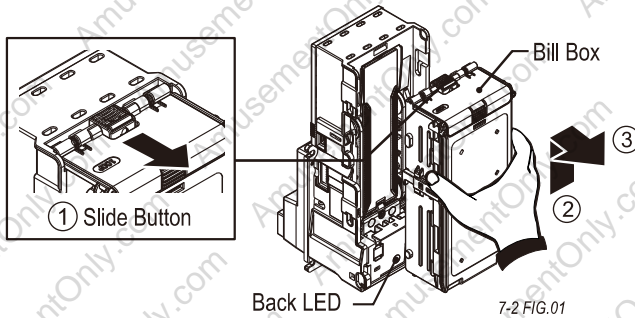

If the error can not be solved after corrective actions or it recurs, please contact ICT for technical support.



International Currency Technologies Corporation

No.28, Ln. 15, Sec. 6, Minquan E. Rd., Neihu Dist., Taipei City 114, Taiwan

sales@ictgroup.com.tw (For Sales)

fae@ictgroup.com.tw (For Customer Service)

Website: www.ictgroup.com.tw

