



Bill Acceptor
NK682
Series
Installation Guide

International Currency Technologies Corp.

Use of Materials Limitations

International Currency Technologies Corporation (ICT) all rights reserved.

All materials contained are the copyrighted property of ICT.

All trademarks, service marks, and trade names are proprietary to ICT.

ICT reserves the right at all times to disclose or to modify any information as ICT deems necessary to satisfy any applicable law, regulation, legal process or governmental request, or to edit, refuse to post or to remove any information or materials, in whole or in part, in ICT's sole discretion.

Contents

1. Introduction

1-1. Overview.....	2
1-2. Features.....	2

2. Specifications..... 2

3. Packing List..... 3

4. Dimension..... 4

5. Installation

5-1. Harness Application.....	7
5-1-1. I/O Circuit.....	11
5-2. DIP Switch Setting.....	13
5-3. Software Download and Upgrade.....	13
5-3-1. USB Pen Drive Firmware Upgrade(NK682T).....	14
5-3-2. USB Cable Firmware Upgrade(NK682T).....	14

6. Maintenance..... 15

7. Troubleshooting..... 16

1. Introduction

1-1. Overview

NK682 series features a high currency verification and recognition with new verification unit to be a new generation bill acceptor.

1-2. Features

- Four way bill insertion acceptable.
- High transaction speed.
- NK682T support update firmware using a USB flash drive.

2. Specifications

General

Acceptance Rate 96% or greater

Note: The incomplete bills such as extremely dirty, wet, broken or wrinkled ones are excluded.

Bill Insertion Four way acceptable

Transaction Speed Approx. 3 seconds to stack

Interface Pulse,
RS232(ICT Protocol),
Parallel

Installation Indoor

Electrical

Power Source 12V DC(10.8V~13.2V DC)

Power Consumption**Without Stacker**

Standby: 0.2A, 2.4W

Operation: 1.42A, 17W

Maximum: 1.5A, 18W

With Stacker

Standby: 0.4A, 4.8W

Operation: 2.2A, 26.4W

Maximum: 3.0A, 36W

Operation Environment

Operation Temperature: -15°C~60°C

Storage Temperature: -30°C~75°C

Humidity: 30%~85%RH

(no condensation)

Mechanical**Outline Dimension**

Refer to page.4

Bill Accepted Width

62mm~68mm

Stacker Capacity

500 bills

Weight

Approx. 0.7kg (Without Stacker)

Approx. 1.8kg (With Stacker)

3. Packing List**Main**

Bill Acceptor

Accessory

Harnesses (Refer to 5-1)

NK682 series Installation Guide

NK682 series DIP Switch Setting Guide

4. Dimension

Without Stacker

Bezel Part Number: 3RBA-FAC3600X

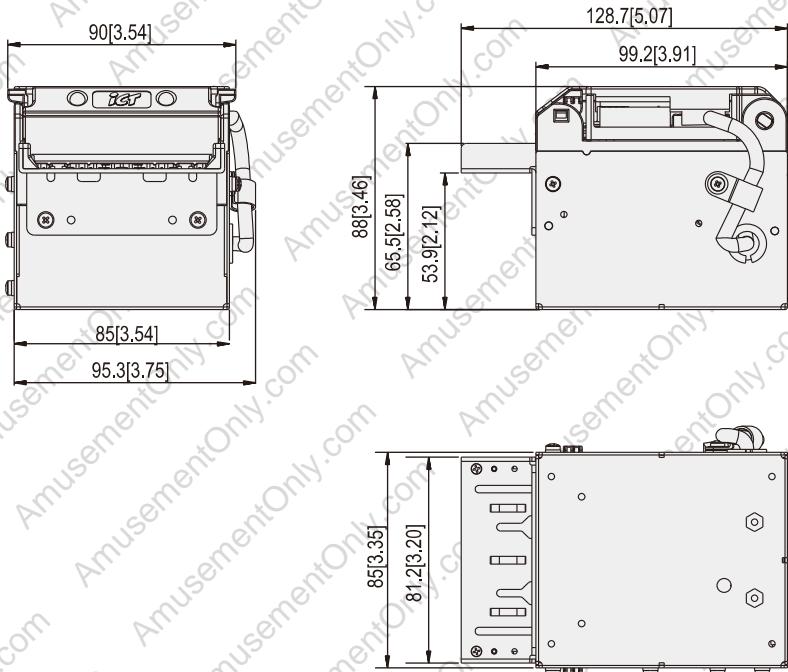

Unit:mm[inch]

4 FIG.01

With Stacker

Bezel Part Number: 3RBA-FAC3600X

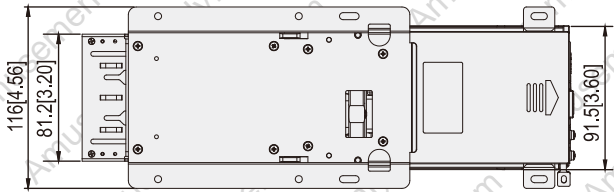
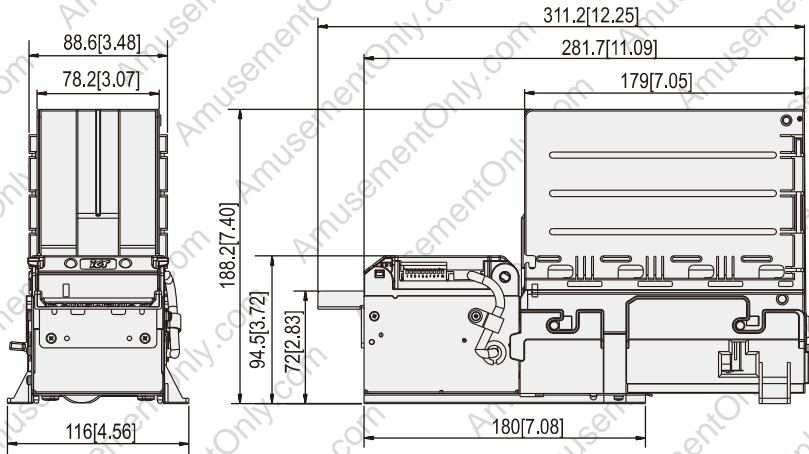

Unit:mm[inch]

4 FIG.02

NK682 series



To install the bill acceptor on your VMC, please be aware of the dimension as below:

[L] : Longer than the maximum length of accepted bills.

[L1] : Bill box capacity depth.

*** [L/2] has to be longer than 80mm to open upper base.**

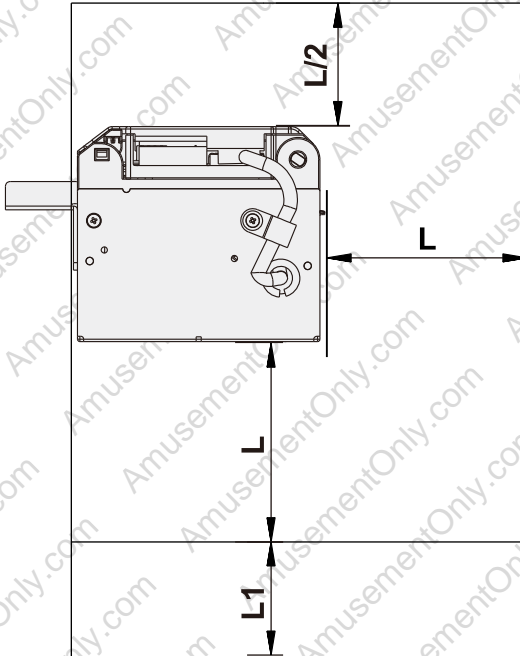

4 FIG.03

5. Installation

5-1. Harness Application

5-1 TABLE 01

Interface	Used Voltage	Usage	Harnesses	Page
Pulse	12V DC	Power & *Data Comm.	WEL-RNK05	8
		Extension Wire	CU-R961-1	8
RS232 or ICT Protocol	N/A	*Data Comm.	WEL-RNK10-1 or 2-BA-RNK10	9
	12V DC	Power	WEL-RNK68211	10

*Data Comm.=Data Communication.

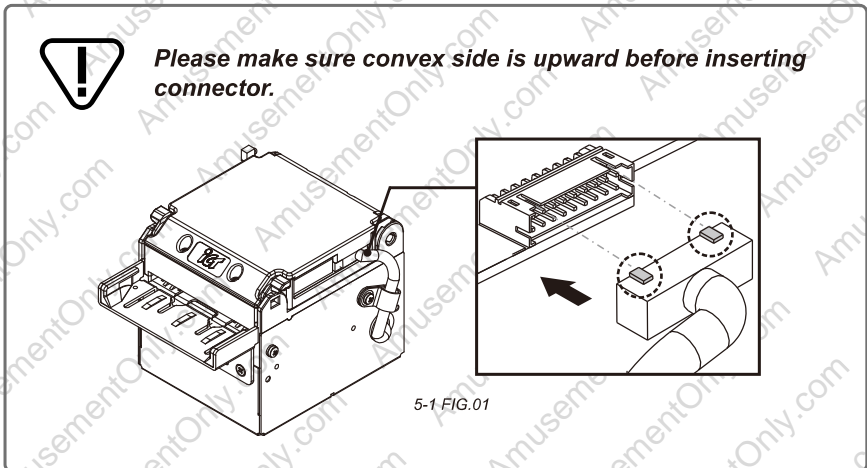

NK682 series

5-1 FIG.02

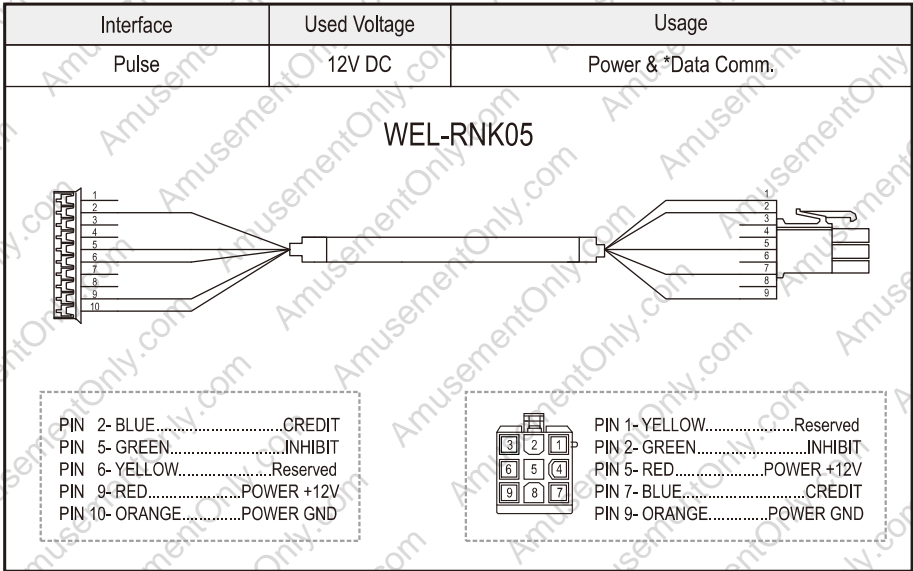

5-1 FIG.03

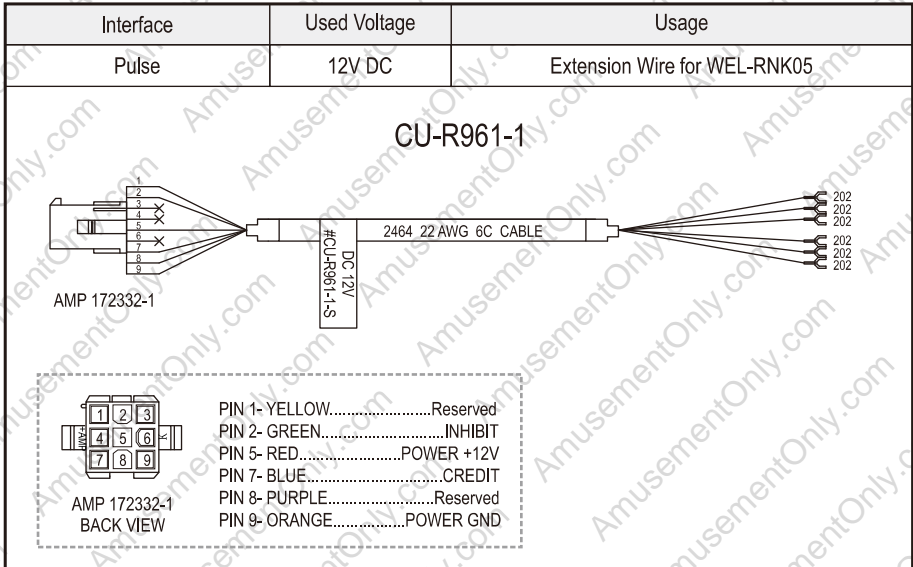

5-1 FIG.04

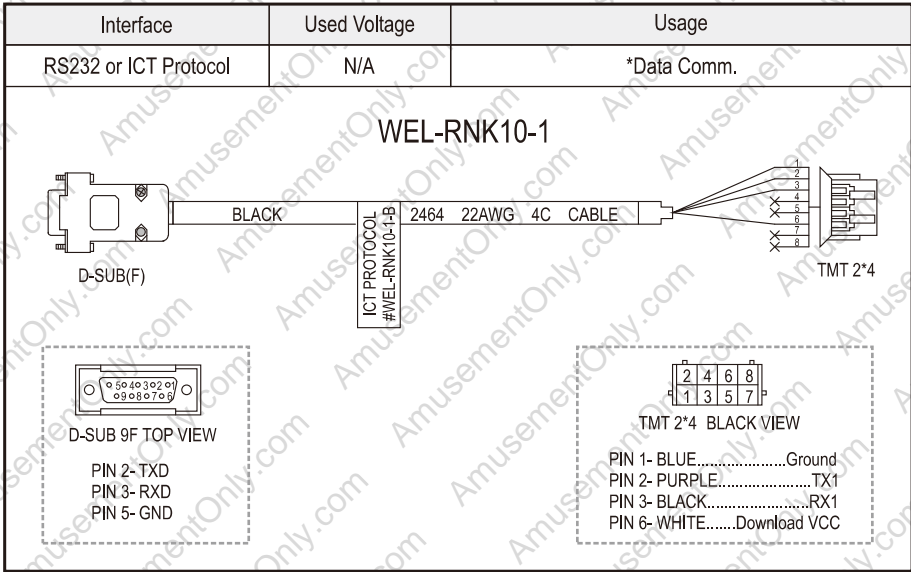

5-1 FIG.05

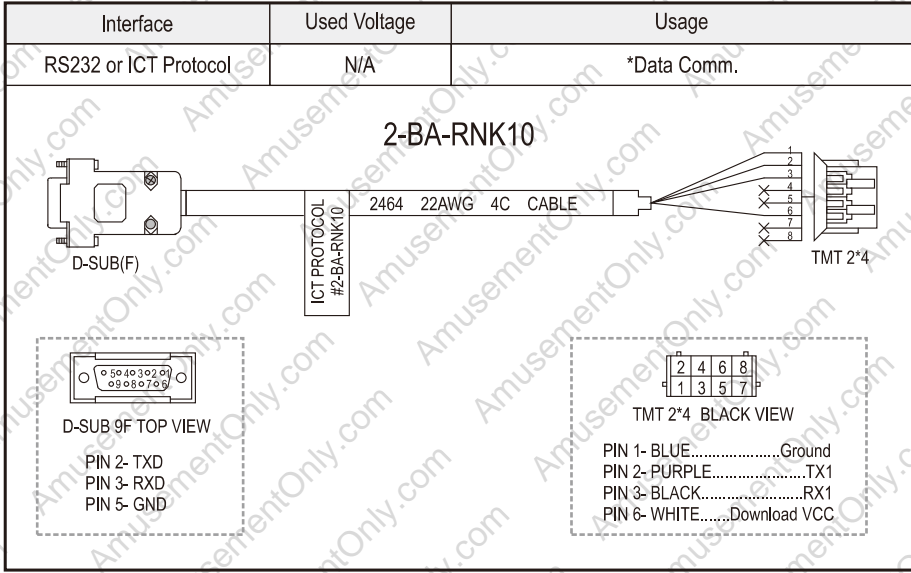

NK682 series

5-1 FIG.06

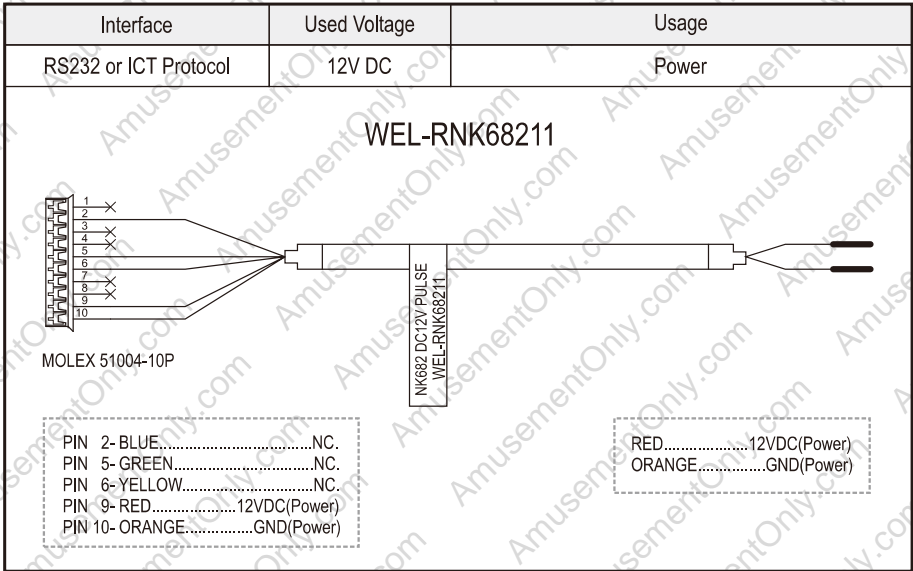

5-1-1. I/O Circuit

Pulse & Parallel Interface

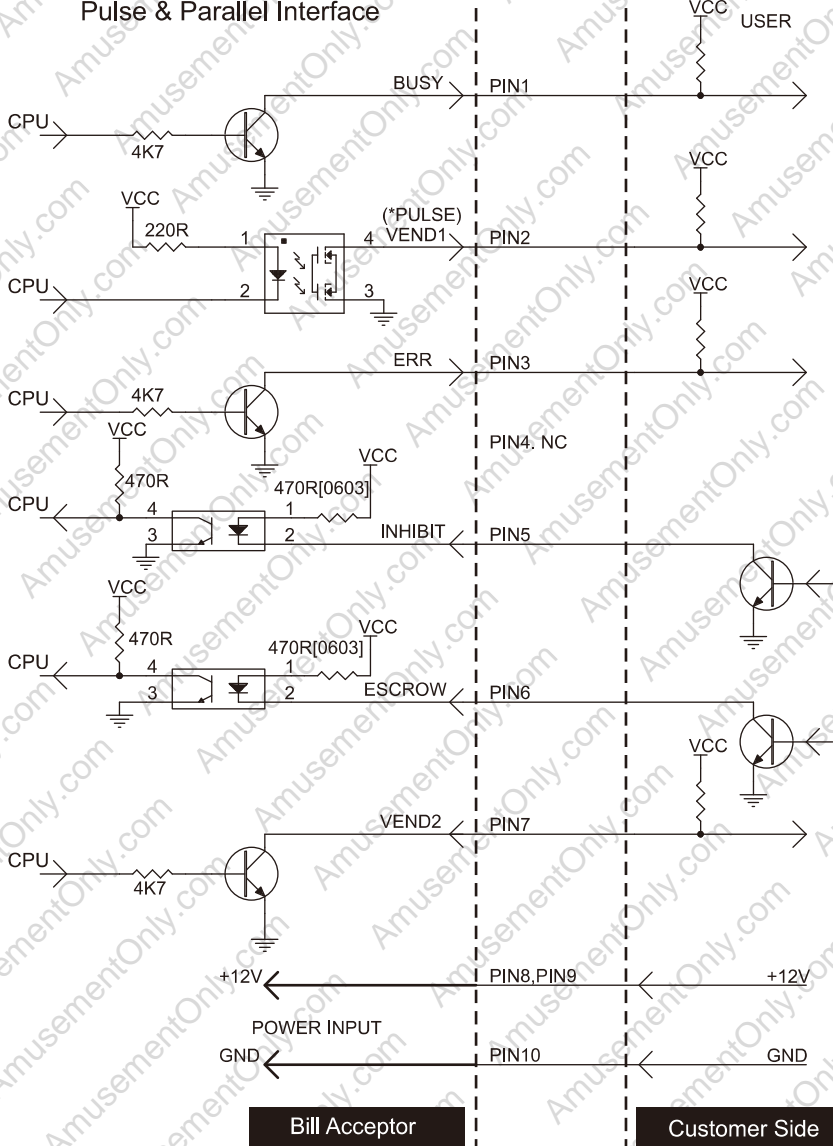

RS232(ICT-Protocol) Interface

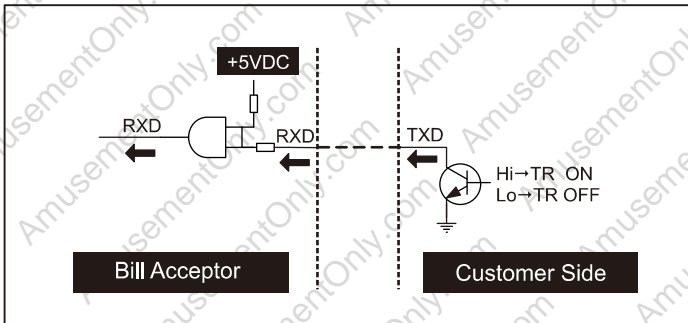
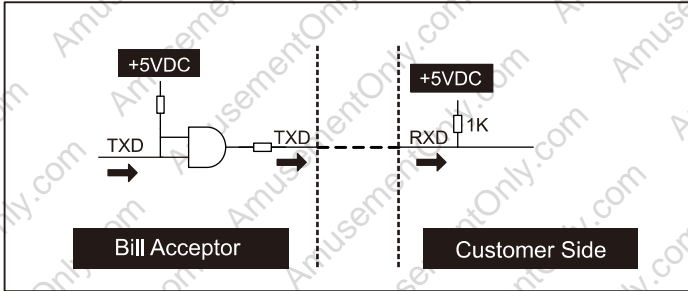

5-2. DIP Switch Setting

There's a serial DIP switches which is located on the side of NK682 series (as 5-2 FIG.01). According to different currencies or interfaces which are used by users, DIP switch settings could be varied to fit users' need.

Please refer to "NK682 series DIP Switch Setting" Guide in the package for more detail.

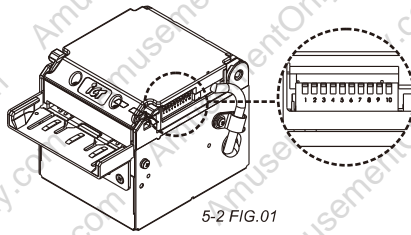

5-3. Software Download and Upgrade

To download and upgrade the software to NK682, the programmer (FP-004) is needed. Please contact ICT to purchase FP-004 and refer to FP-004 user guide for software download and upgrade information.

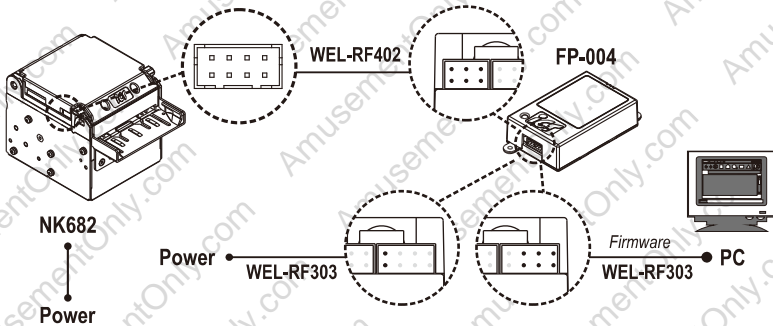

Power must be applied to Bill Acceptor after connecting.

5-3-1. USB Pen Drive Firmware Upgrade(NK682T)

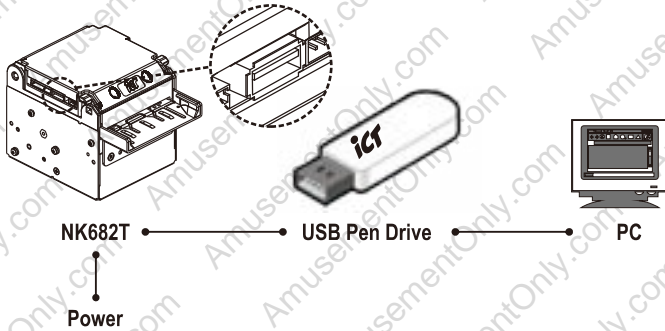

! Power must be applied to Bill Acceptor after connecting.

5-3-2. USB Cable Firmware Upgrade(NK682T)

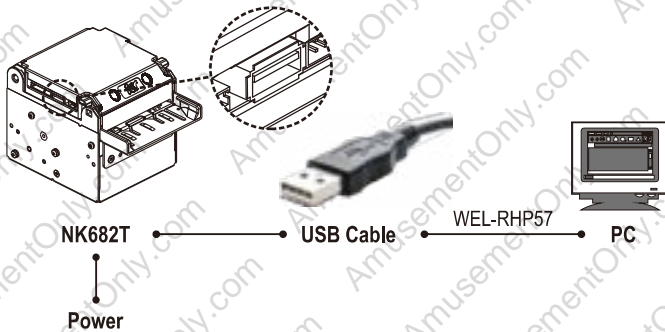

! Power must be applied to Bill Acceptor after connecting.

6. Maintenance

To make sure the bill acceptor always works smoothly, please clean the internal parts regularly.

To clean the internal parts:

1. Turn Bill Acceptor off.
2. Press the buttons on the side of bill path and pull the unit out.
3. Use a soft, dry cloth, or towel to clean the bill path and sensors.

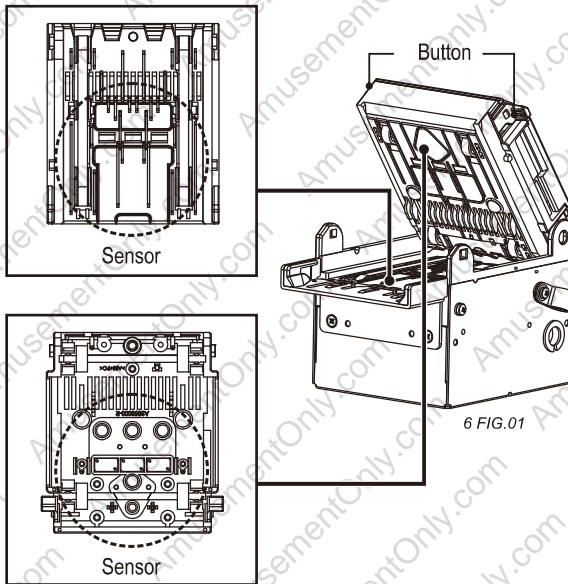

	Maintenance Notice	
	<i>(Any improper maintenance will result invalid warranty.)</i>	
	Recommended	Mild, non-abrasive, soap water.
DO NOT USE	Organic solvent , Alcohol, Volatile liquid.	

7. Troubleshooting

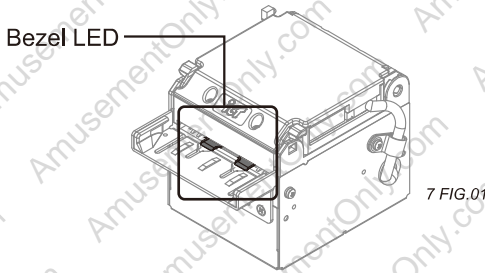

7 TABLE 01

Flashes		Status	Corrective Actions
Red	Green		
1	1	Bill jammed.	Open bill path unit and then remove the jammed bill.
2	1	Disable.	Inspect for right DIP switch setting.
3	N/A	Recognition sensor, Input sensor error	Inspect for foreign objects on sensor or bill path and clean.
3	2	Hook error.	Inspect for foreign objects on hook or bill path and clean.
3	4	Output sensor error.	Inspect for foreign objects on sensor and clean.
4	1	Anti-fishing sensor error.	Inspect for foreign objects on bill path and clean.
5	1	Stacker has been removed.	Replace the stacker.
6	1	Stacker error or stacker full.	Empty the stacker.
7	1	Motor error.	Inspect for foreign objects on bill path and clean.



If the error can not be solved after corrective actions or happen again, please contact ICT for technical support.

NK682 series



International Currency Technologies Corporation

No.28, Ln. 15, Sec. 6, Minquan E. Rd., Neihu Dist., Taipei City 114, Taiwan

sales@ictgroup.com.tw (For Sales)

fae@ictgroup.com.tw (For Customer Service)

Website: www.ictgroup.com.tw

AmusementOnly.com