



Bill Acceptor

LX7 Series

Installation Guide

International Currency Technologies Corp.

Use of Materials Limitations

International Currency Technologies Corporation (ICT) all rights reserved.

All materials contained are the copyrighted property of ICT.

All trademarks, service marks, and trade names are proprietary to ICT.

ICT reserves the right at all times to disclose or to modify any information as ICT deems necessary to satisfy any applicable law, regulation, legal process or governmental request, or to edit, refuse to post or to remove any information or materials, in whole or in part, in ICT's sole discretion.

Contents

1. Introduction

1-1. Overview 2

1-2. Features 2

2. Specifications 3

3. Packing List 4

4. Dimension 5

5. Installation

5-1. Harness Application 8

5-1-1. I/O Circuit 16

5-2. DIP Switch Setting 19

5-3. Software Download and Upgrade 19

6. Maintenance 20

7. Troubleshooting

7-1. Bezel LED Errors 21

7-2. Back LED Errors 22



1. Introduction

1-1. Overview

LX7 is a bill acceptor feature the water drainage path to offer maximum protection against water and humidity.

1-2. Features

- Four-way bill insertion acceptance.
- Auto-calibrating.
- Windows XP compatible and USB interface available.
- Safe lock removable and 200 or 600 bills box capacity.
- Selective lock between plastic knob and tubular lock.

2. Specifications

General

Acceptance Rate 96% or greater

Note: The acceptance rate excludes notes that are dirty, wet, broken or wrinkled.

Interface Pulse, RS232 A0, ICT Protocol <RS232>, MDB, ICT Protocol <USB (Optional)>

* Combination is possible. Ex. Pulse+MDB

Transaction Speed Approx. 3 seconds to stack

Bill Insertion Four-way acceptable



Installation: Indoor use only!!

Electrical

Power Source 12V DC (10.8~13.2V DC)
24V AC (21.6~26.4V AC)
24V/34V DC (20.0~42.5V DC)

Power Consumption

12V DC-	Standby : 0.3A, 4W Operation: 0.8A, 10W Maximum: 2.5A, 30W
24V AC-	Standby : 0.2A, 5W Operation: 0.5A, 12W Maximum: 1.5A, 36W
24V/34V DC-	Standby : 0.15A, 6W Operation: 0.4A, 14W Maximum: 1.35A, 46W

Operation Environment Operation Temperature: -15°C~60°C
Storage Temperature: -30°C~70°C
Humidity: 30%~85% RH (no condensation)

Mechanical

Bill Capacity	Approx. 200 or 600 bills
Outline Dimension	Plastic knob- Refer to page.6 Tubular lock- Refer to page.7
Weight	Approx. 1.25kg
Lock Type	Plastic Knob or Tubular lock (Customize)
Bill Accepted Width	62~72mm

3. Packing List

Main	Bill Acceptor
Accessory	Harness: Refer to 5-1 LX7 Installation Guide LX7 DIP Switch Setting Guide A Pair of keys (For tubular lock only)

4. Dimension

Bezel

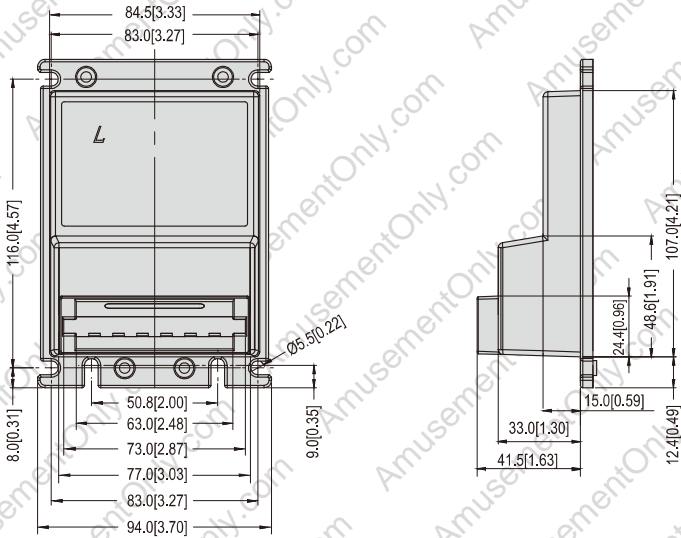

Unit : mm [inch]

4 FIG.01



Plastic Knob

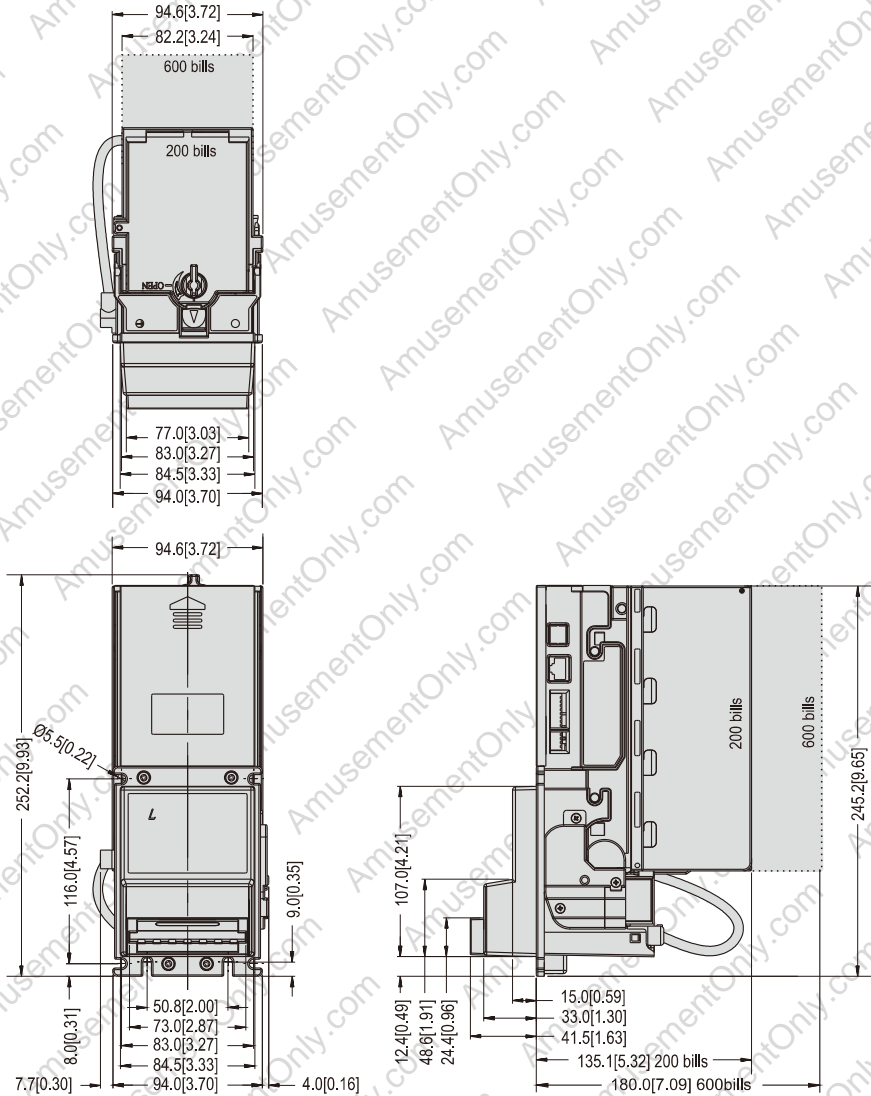

Unit : mm [inch]

4 FIG.02

Tubular lock

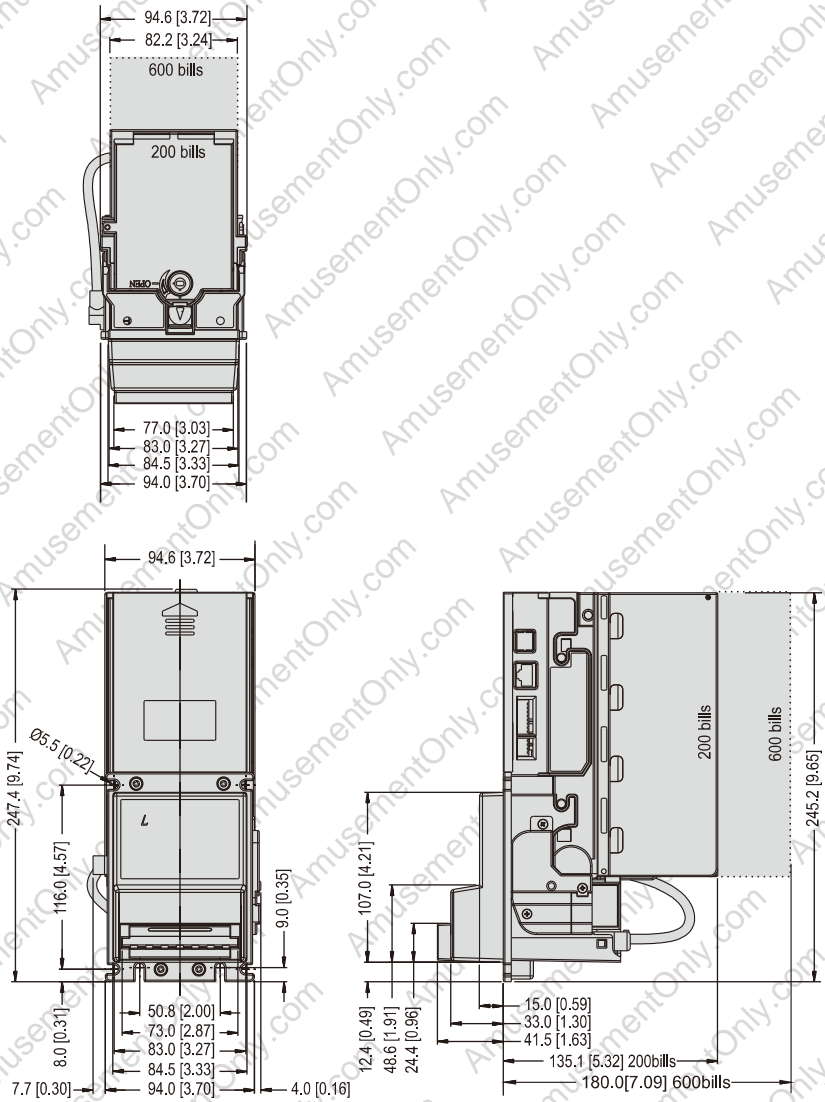

Unit : mm [Inch]

4 FIG.03

5. Installation



When LX7 is installed in down stacker direction, please remove the rubber stopper.

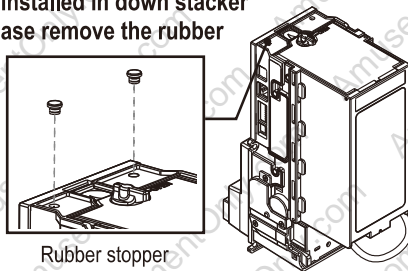

Rubber stopper

5 FIG.01

5-1. Harness Application

5-1 TABLE 01

Interface		Used Voltage	Usage	Harness	Page
Pulse	12V DC	12V DC	Power & *Data Comm.	WEL-RV701	9
			Extension Wire	CU-R961-1	10
	24V AC	24V AC	Power & *Data Comm.	WEL-RV702**	11
			Power & *Data Comm.	WEL-RV703**	12
MDB		24V/34V DC	Power & *Data Comm.	WEL-RM006	13
ICT Protocol	RS232	12V DC	*Data Comm.	WEL-RV706-1 or 2-BA-RV706	14
			Power	WEL-RV701	9
			Extension Wire	CU-R961-1	10
	USB	12V DC	*Data Comm.	WEL-RU1180 (Optional)	15
			Power	WEL-RV701	9
			Extension Wire	CU-R961-1	10
RS232 A0		12V DC	*Data Comm.	WEL-RV706-1 or 2-BA-RV706	14
			Power	WEL-RV701	9
			Extension Wire	CU-R961-1	10

* Data Comm. : Data Communication.

** Please select between WEL-RV702 and WEL-RV703 according to the connector on your VMC.

5-1 FIG.01

Interface	Used Voltage	Usage
Pulse	12V DC	Power & *Data Comm.
RS232 for ICT Protocol	12V DC	Power
USB for ICT Protocol	12V DC	Power
RS232 A0	12V DC	Power

WEL-RV701

PIN 1- PURPLE.....	CREDIT_RELAY (COMMON)
PIN 2- BLUE.....	CREDIT_RELAY (N.O.)
PIN 3- RED.....	12VDC (POWER)
PIN 4- YELLOW.....	INHIBIT+
PIN 18- GREEN.....	INHIBIT-
PIN 20- ORANGE.....	GND (POWER)

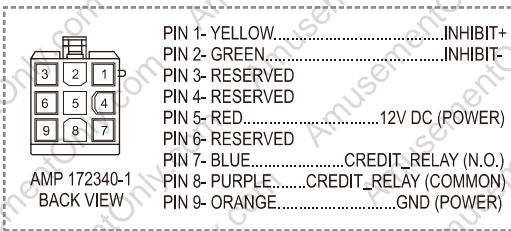
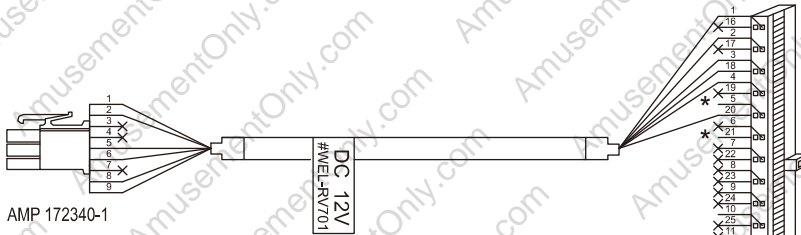

BLK-15*2

Interface	Used Voltage	Usage
Pulse	12V DC	Extension Wire for WEL-RV701
RS232 for ICT Protocol	12V DC	
USB for ICT Protocol	12V DC	
RS232 A0	12V DC	

CU-R961-1

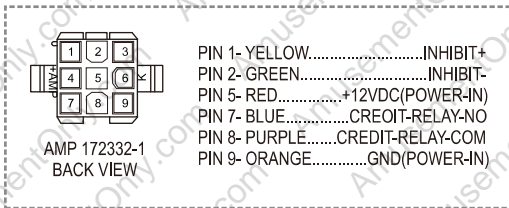
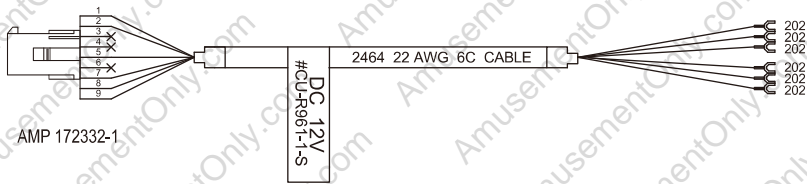

5-1 FIG.03

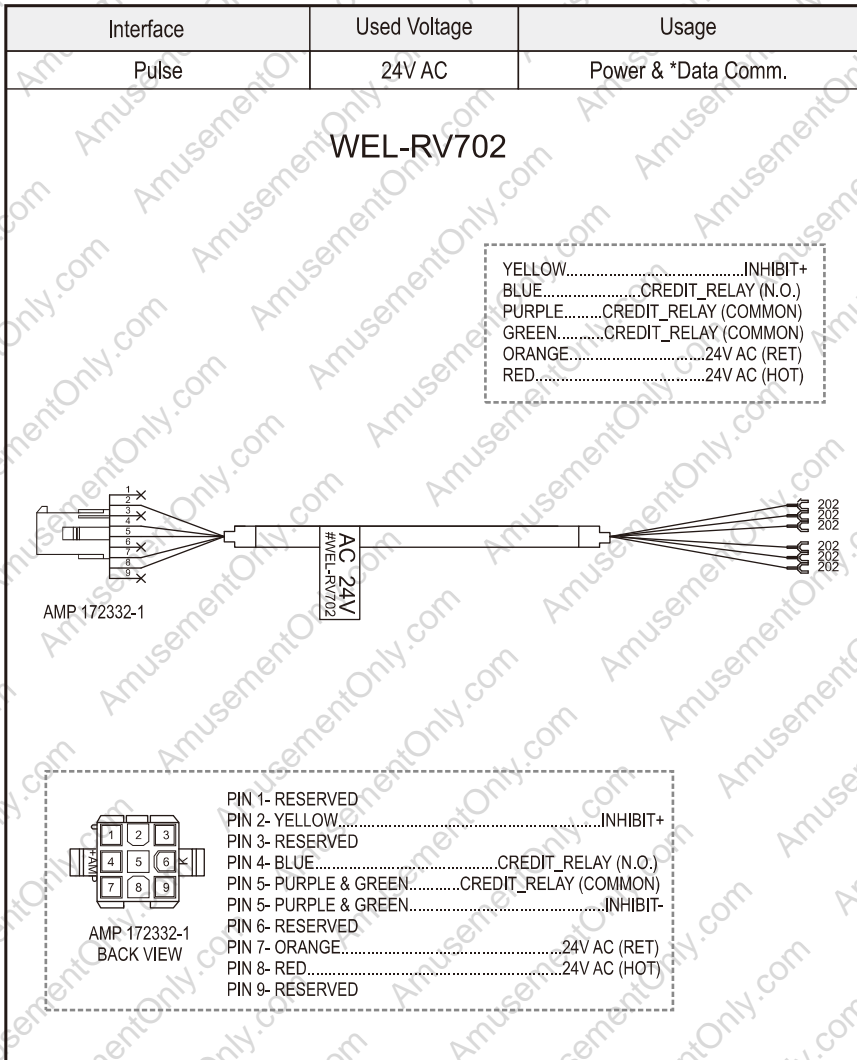

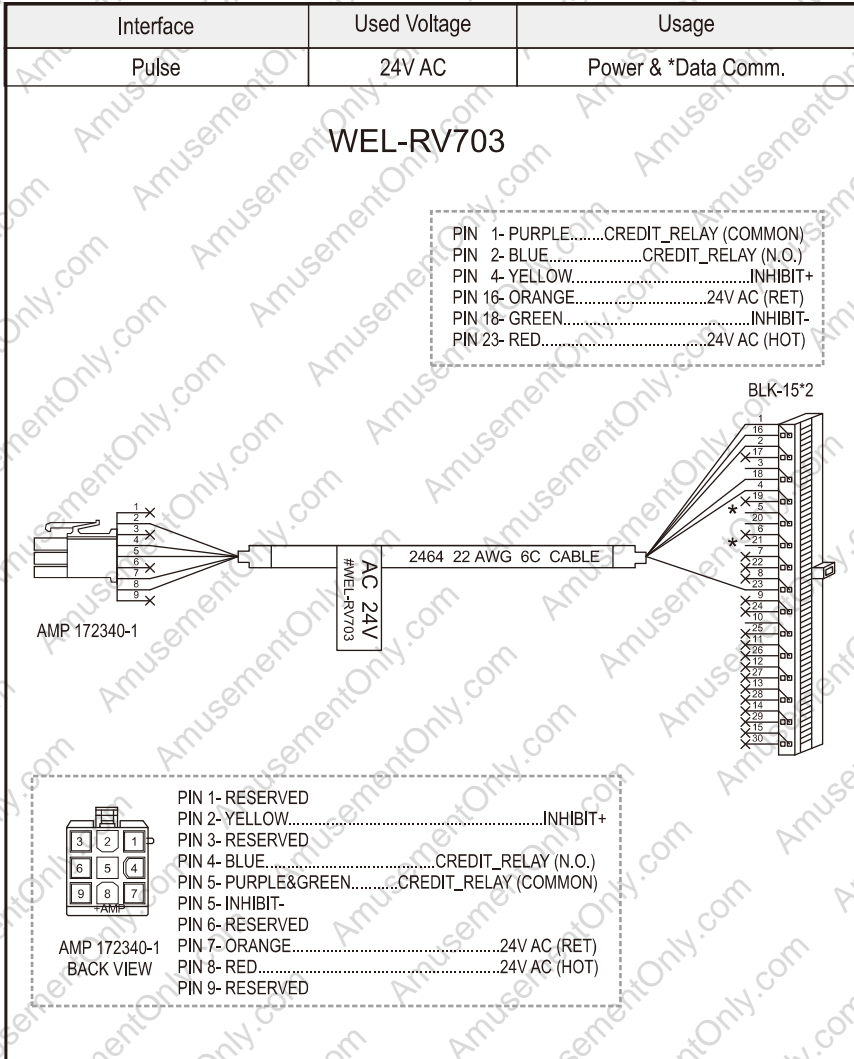

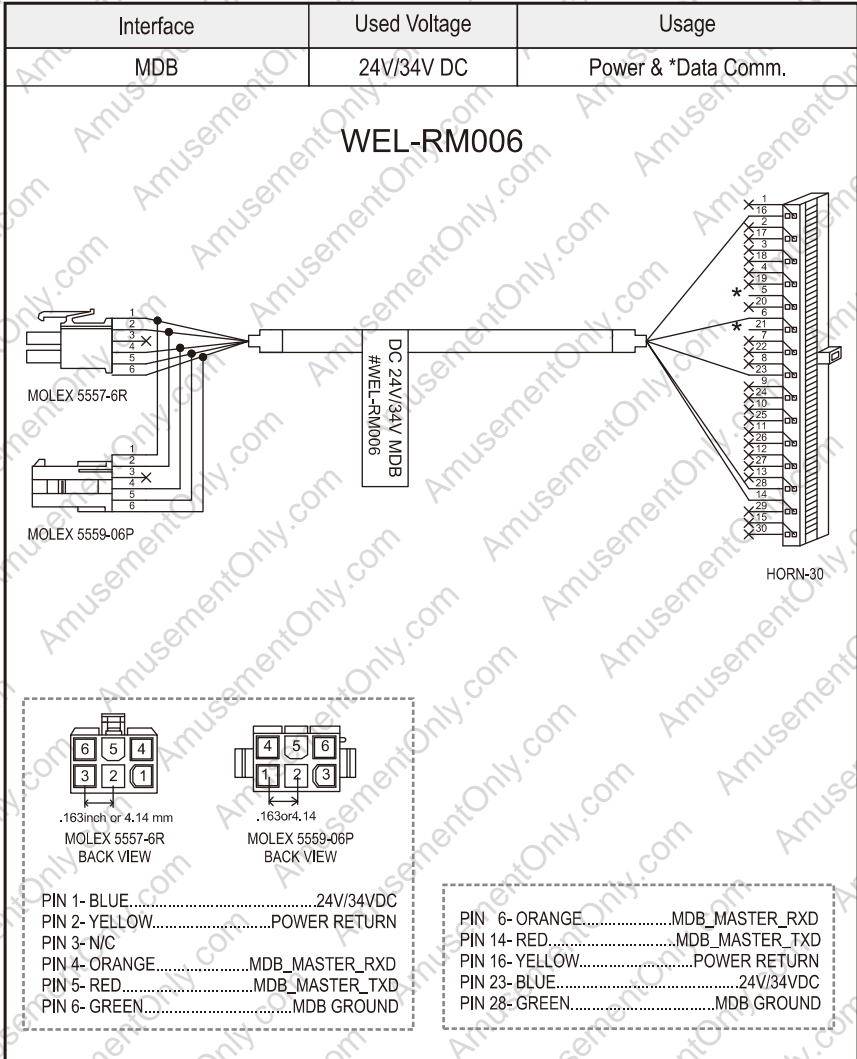

5-1 FIG.05

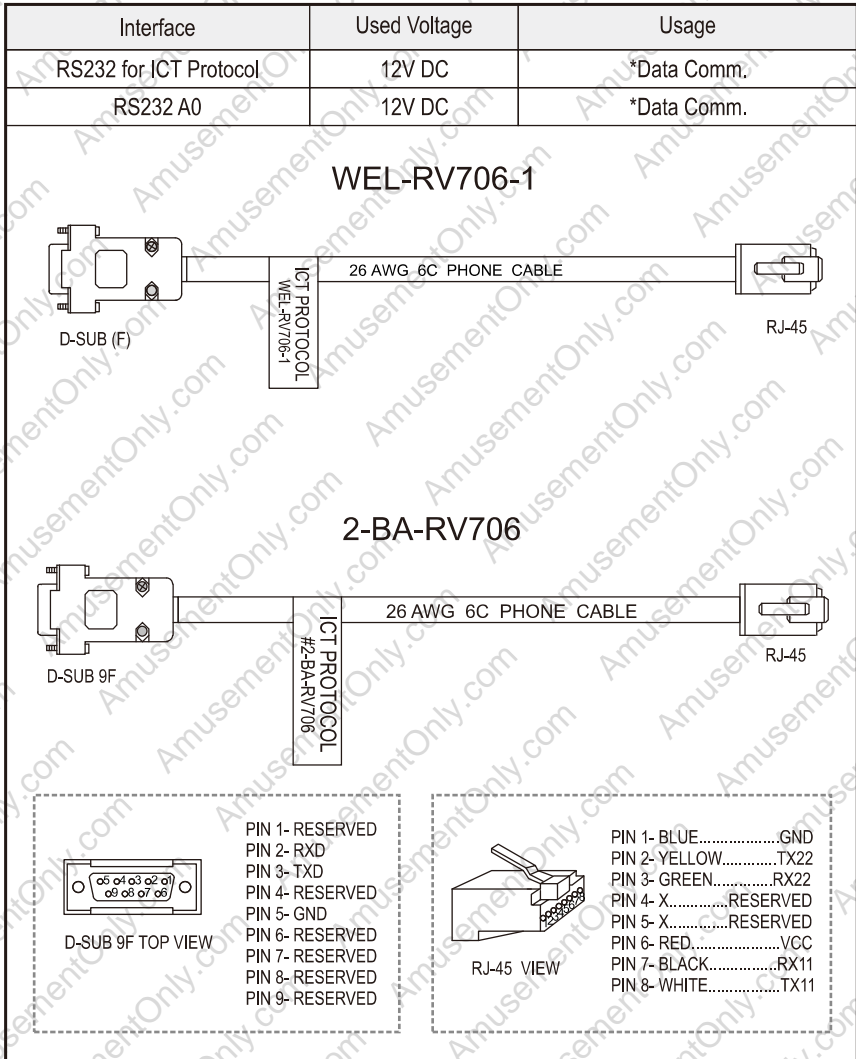

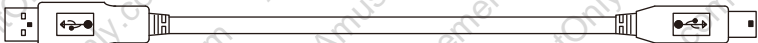

5-1 FIG.07

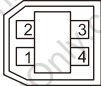
Interface	Used Voltage	Usage												
USB for ICT Protocol	12V DC	*Data Comm.												
<p data-bbox="461 363 658 432">WEL-RU1180 (Optional)</p>  <p data-bbox="206 692 297 711">USB-A TYPE</p> <p data-bbox="833 692 925 711">USB-B TYPE</p> <div style="display: flex; justify-content: space-around; margin-top: 20px;"> <div data-bbox="163 1050 549 1214" style="border: 1px dashed black; padding: 5px;">  <p data-bbox="176 1155 312 1174">USB-A BACK VIEW</p> <table border="0" data-bbox="333 1091 530 1174"> <tr><td>PIN 1- RED.....</td><td>VCC</td></tr> <tr><td>PIN 2- WHITE.....</td><td>D-</td></tr> <tr><td>PIN 3- GREEN.....</td><td>D+</td></tr> <tr><td>PIN 4- BLACK.....</td><td>GND</td></tr> </table> </div> <div data-bbox="636 1050 956 1214" style="border: 1px dashed black; padding: 5px;">  <p data-bbox="665 1181 804 1200">USB-B BACK VIEW</p> <table border="0" data-bbox="822 1091 929 1174"> <tr><td>PIN 1- RED</td></tr> <tr><td>PIN 2- WHITE</td></tr> <tr><td>PIN 3- GREEN</td></tr> <tr><td>PIN 4- BLACK</td></tr> </table> </div> </div>			PIN 1- RED.....	VCC	PIN 2- WHITE.....	D-	PIN 3- GREEN.....	D+	PIN 4- BLACK.....	GND	PIN 1- RED	PIN 2- WHITE	PIN 3- GREEN	PIN 4- BLACK
PIN 1- RED.....	VCC													
PIN 2- WHITE.....	D-													
PIN 3- GREEN.....	D+													
PIN 4- BLACK.....	GND													
PIN 1- RED														
PIN 2- WHITE														
PIN 3- GREEN														
PIN 4- BLACK														



5-1-1. I/O Circuit

Pulse Interface.

5-1-1 FIG.01

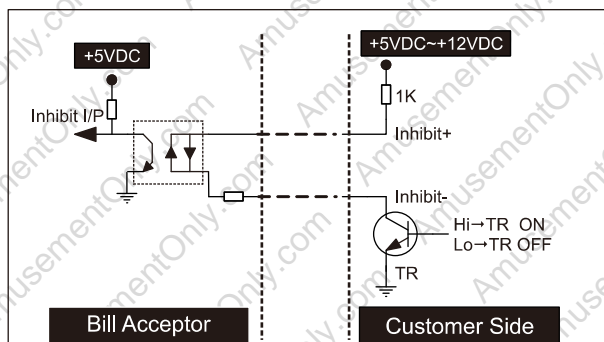
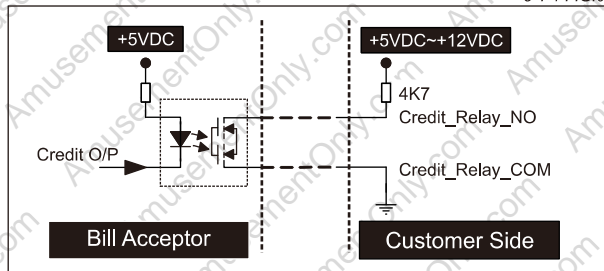

BA Status	DIP SW Setting	Control Signal
Inhibit	Inhibit Active	Low
		High
Enable	Inhibit Active	High
		Low

MDB Interface.

5-1-1 FIG.02

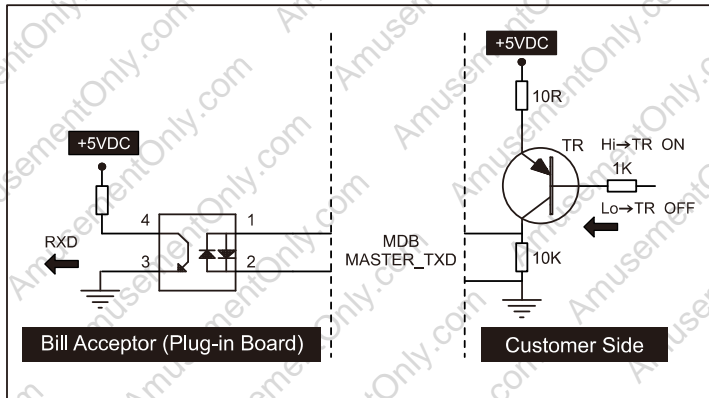
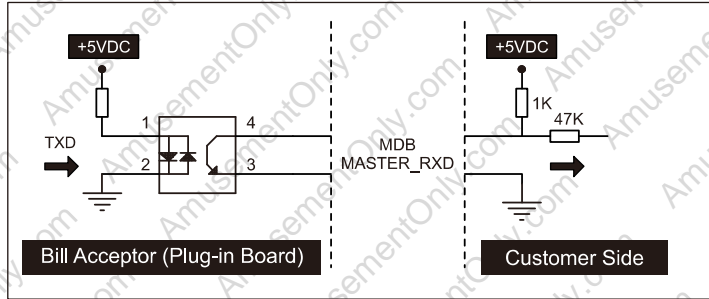



ICT-Protocol & RS232 A0 Interface.

5-1-1 FIG.03

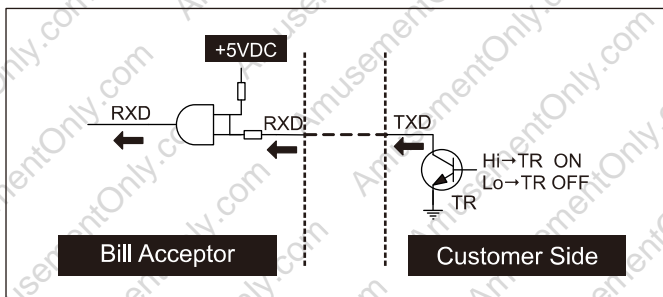
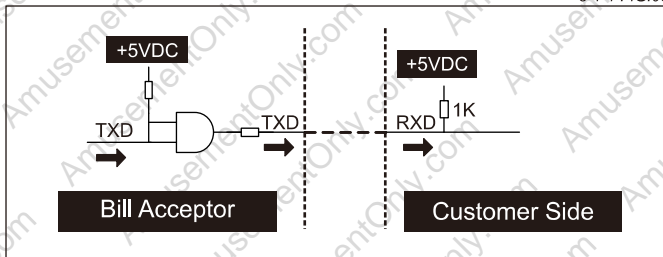

5-2. DIP Switch Setting

There are two serial DIP switches which are set on the side of LX7 (as FIG.01). According to different currencies which are used by users, DIP switch settings could be varied to fit users' needs. There is also a serial DIP switch on the base of the unit for inside interface settings (as FIG.02).

Please refer to "LX7 DIP Switch Setting Guide" in the package for more details.

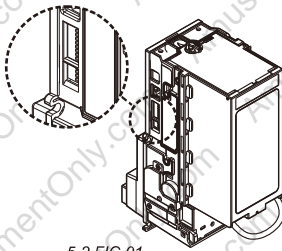

5-2 FIG.01

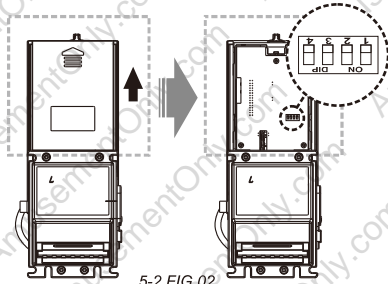

5-2 FIG.02

5-3. Software Download and Upgrade

To download and upgrade the software to LX7, the programmer (FP-004) is needed. Please contact ICT to purchase FP-004 and refer to FP-004 user guide for software download and upgrade information.

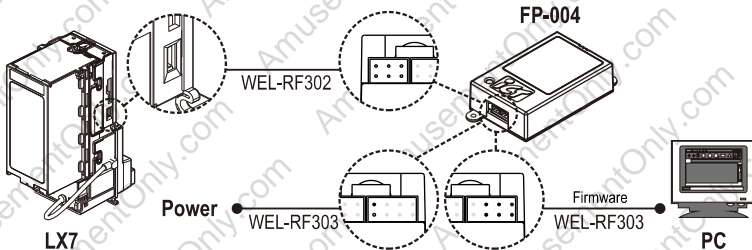

Please turn on Bill Acceptor after connecting.

6. Maintenance

To make sure the bill acceptor always works smoothly, please clean the internal parts every two weeks to every two months.

To clean the internal parts:

1. Press the buttons on the sides of bill path and pull the unit out.

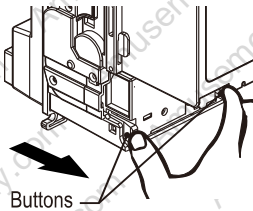

6 FIG.01-1

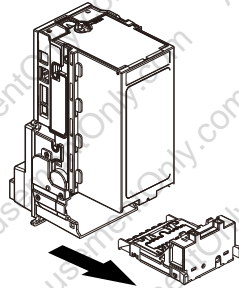

6 FIG.01

2. Use a soft, dry cloth or towel to clean the bill path and sensors.

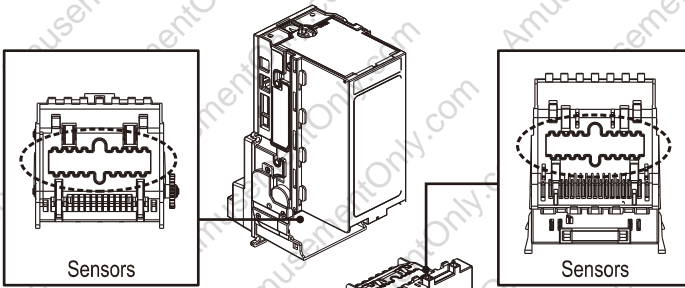

6 FIG.02

Maintenance Notice (Any improper maintenance will invalidate the warranty.)	
	Recommended Mild, non-abrasive, soap water.
DO NOT USE	Organic solvent , Alcohol, Volatile liquid.

7. Trouble Shooting

7-1. Bezel LED Errors

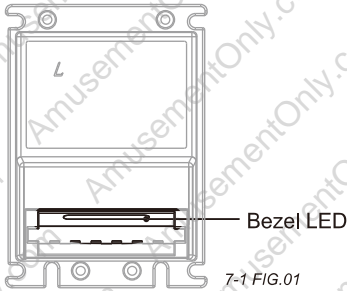

7-1 TABLE 01

LED Flashes		Status	Corrective Actions
Red	Green		
	1	White Card Calibration	Please calibrate with ICT white calibration card.
1		Bill jammed.	Remove the bill box by sliding the top button and the bill path (as 7-2 FIG.01), and then remove the jammed bill.
2		Disable.	Inspect the right DIP switch setting.
3		Recognition sensor module error.	Inspect the foreign objects on sensor or bill path and clean.
3+2		Hook sensor error.	Inspect the foreign objects on security hook and clean.
3+4		Out sensor error.	Inspect the foreign objects on sensor or bill path and clean.
4		Anti-string sensor error or a stringing attempt has detected.	Inspect the foreign objects on sensor or bill path and clean.
5		Bill box has been removed.	Replace the bill box.
6		Stacker error or stacker full.	Empty the bill box.
7		Motor error.	Inspect the foreign objects on bill path and clean.

7-2. Back LED Errors

7-2 TABLE 01

LED Flashes	Status	Corrective Actions
Green		
1	White Card Calibration	Please calibrate with ICT white calibration card.
1	Bill jammed.	Remove the bill box by sliding the top button and the bill path (as 7-2 FIG.01), and then remove the jammed bill.
2	Disable.	Inspect the right DIP switch setting.
3	Recognition sensor module error.	Inspect the foreign objects on sensor or bill path and clean.
3+2	Hook sensor error.	Inspect the foreign objects on security hook and clean.
3+4	Out sensor error.	Inspect the foreign objects on sensor or bill path and clean.
4	Anti-string sensor error or a stringing attempt has detected.	Inspect the foreign objects on sensor or bill path and clean.
5	Bill box has been removed.	Replace the bill box.
6	Stacker error or stacker full.	Empty the bill box.
7	Motor error.	Inspect the foreign objects on bill path and clean.

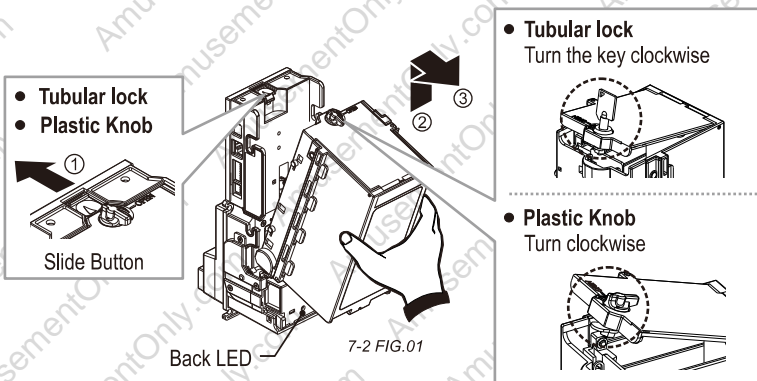

If the error can not be solved after corrective actions or it recurs, please contact ICT for technical support.



Taiwan

International Currency Technologies Corporation

No.28, Ln. 15, Sec. 6, Minquan E. Rd., Neihu Dist., Taipei City 114, Taiwan

sales@ictgroup.com.tw (For Sales)

fae@ictgroup.com.tw (For Customer Service)

Website: www.ictgroup.com.tw

