



L70T-P5 / L77T-P5

Bill Acceptor



# Installation Guide

International Currency Technologies Corp.

## ***Use of Materials Limitations***

International Currency Technologies Corporation (ICT) all rights reserved.

All materials contained are the copyrighted property of ICT.

All trademarks, service marks, and trade names are proprietary to ICT.

ICT reserves the right at all times to disclose or to modify any information as ICT deems necessary to satisfy any applicable law, regulation, legal process or governmental request, or to edit, refuse to post or to remove any information or materials, in whole or in part, in ICT's sole discretion.

# Contents

1. Introduction	
1-1. Overview .....	2
1-2. Features .....	2
2. Specifications .....	3
3. Packing List .....	5
4. Dimension .....	6
5. Installation	
5-1. Harness Application .....	15
5-1-1. I/O Circuit .....	39
5-2. DIP Switch Setting .....	45
5-3. Software Download and Upgrade .....	45
6. Maintenance .....	46
7. Troubleshooting .....	47

---

Appendix\_ccTalk Information

# **1. Introduction**

## **1-1. Overview**

The L Series bill acceptor combines improved bill-sensing technology with lightweight and durable plastic construction. It also features fast software updating, automatic self-adjusting sensor system, and easy maintenance to increase acceptance rates and reduce bill jammed.

## **1-2. Features**

- Auto-calibration.
- Easy maintenance.
- Fast program update.
- Selective interfaces.
- Anti-string technology.
- Speedy bill transaction.
- Multicolor illumination bezel design.
- Multinational currencies acceptable.
- Fixed width/ multi-width bill acceptable.
- Lightweight and durable plastic construction.
- New generation design of verification system.

## 2. Specifications

### **General**

**Acceptance Rate** 96% or greater

*\*Note: The Incomplete bills such as extremely dirty, wet, broken, or wrinkled ones are excluded!*

**Bill Insertion** Four way acceptable

**Transaction Time** Approx. 3 seconds to stack

### **Interface**

#### **L70#:**

Pulse, RS232, RS232 A0, ccNet(compatible), MDB, ccTalk.

#### **L70:**

Pulse, RS232, RS232 A0, Parallel A1 .

#### **L70F, L77F:**

Pulse, RS232, RS232 A0, ccNet(compatible), MDB, ccTalk, Pulse(Out of service).

#### **L83:**

Pulse, RS232, RS232 A0, ccNet(compatible), MDB, ccTalk, RS232 A1, Parallel, Pulse(Out of service), Parallel A4.

#### **L83#:**

Pulse, RS232, RS232 A0, ccNet(compatible), MDB, ccTalk, RS232 A1, Pulse(Out of service)

#### **L70T, L77T:**

Pulse, RS232, RS232 A0, ccNet(compatible), MDB, ccTalk, Pulse(Out of service) , V2.2.

*\*Note: For ccTalk information, please refer to Appendix.*

## Electrical

### Power Source

**L70#, L70F, L77F, L83#, L70T, L77T:**

12V DC(10~16V DC)

**Others:** 12V DC(10.8~13.2V DC)

### Power Consumption

Standby : 0.3A, 3.6W

Operation: 1.2A, 14.4W

Maximum: 2A, 24W

### Operation Environment

Operation Temperature:

**L70, L83:** 0°C~50°C

**L70F, L77F, L70T, L77T:** 0°C~60°C

**L70#, L83#:** 0°C~65°C

Storage Temperature: -20°C~70°C

Humidity: 30%~85%RH(no condensation)

## Mechanical

### Outline Dimension

**L70#-P2/P5, L70F-P2/P5 :**

N Type Bezel Refer to page. 6

O Type Bezel Refer to page. 7

**L77F-P2/P5:** I Bezel Refer to page. 8

**L83-P3/P6, L83#-P3/P6:**

E Type Bezel Refer to page. 9

F Type Bezel Refer to page.10

Y Type Bezel Refer to page.11

**L70T-P5, L77T-P5:**

Without metal bracket Refer to page.12

With metal bracket Refer to page.13

### Bill Box Capacity

**L70#-P2, L70F-P2:** Approx.200 bills

**L70#-P5, L70F-P5:** Approx.500 bills

**L77F-P2:** Approx.150 bills

**L77F-P5:** Approx.500 bills

**L83-P3, L83#-P3:** Approx.300 bills

**L83-P6, L83#-P6:** Approx.600 bills

**L70T-P5, L77T-P5:** Approx.500 bills

### Weight

**L70#, L70F:** Approx.0.52kg  
**L70#-P2, L70F-P2:** Approx.1.25kg  
**L70#-P5, L70F-P5:** Approx.1.4kg  
**L77F:** Approx.0.44kg  
**L77F-P2:** Approx.1.35kg  
**L77F-P5:** Approx.1.42kg  
**L83, L83#:** Approx.0.8kg  
**L83-P3, L83#-P3:** Approx.1.46kg  
**L83-P6, L83#-P6:** Approx.1.65kg  
**L70T-P5, L77T-P5:** (Without metal bracket) Approx.1.42kg  
 (With metal bracket) Approx.7kg

### Bill Accepted Width

**L70#-P2/P5, L70F-P2/P5:**  
 (67mm) 59mm~67mm  
 (71mm) 59mm~71mm  
**L77F-P2/P5:** 72mm~77mm  
**L83-P3/P6, L83#-P3/P6:**  
 61mm~83mm  
 61mm~79mm(Y Type Bezel)  
**L70T-P5:** 65mm~70mm  
**L77T-P5:** 72mm~77mm

### Installation

### Indoor

## 3. Packing List

### Main

Bill Acceptor

### Accessory

Harness: Refer to **5-1**  
 Bezel Sticker  
 Screw Pack  
 L Series Installation Guide  
 L Series DIP Switch Setting Guide

## 4. Dimension

L70 N Type Bezel: A Bezel(67mm) and B Bezel(71mm)

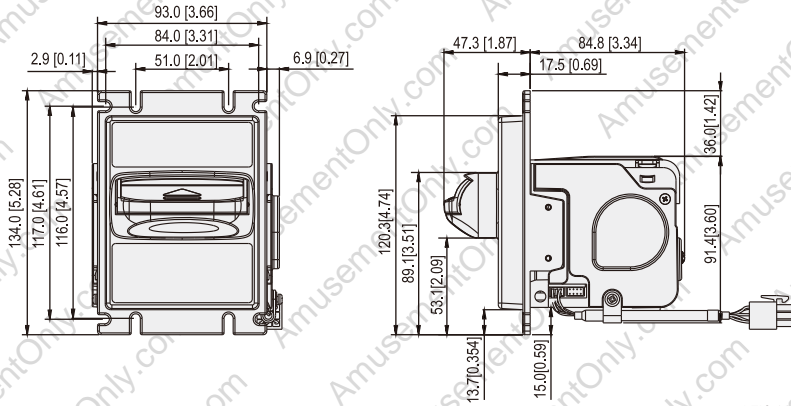

4 FIG.01

L70-P2/P5 N Type Bezel: A Bezel(67mm) and B Bezel(71mm)

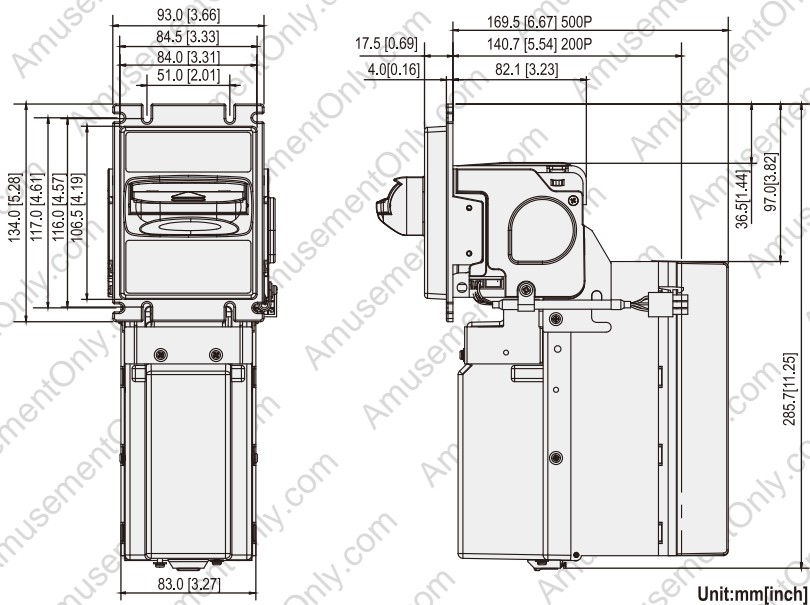

Unit:mm[inch]

4 FIG.02

L70 O Type Bezel (71mm)

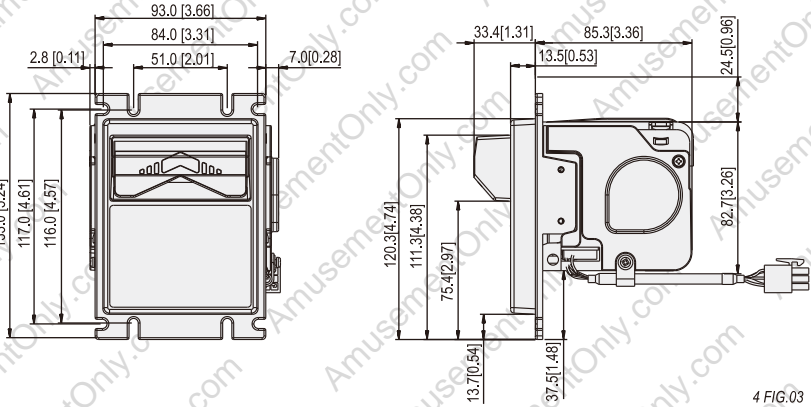

4 FIG.03

L70-P2/P5 O Type Bezel (71mm)

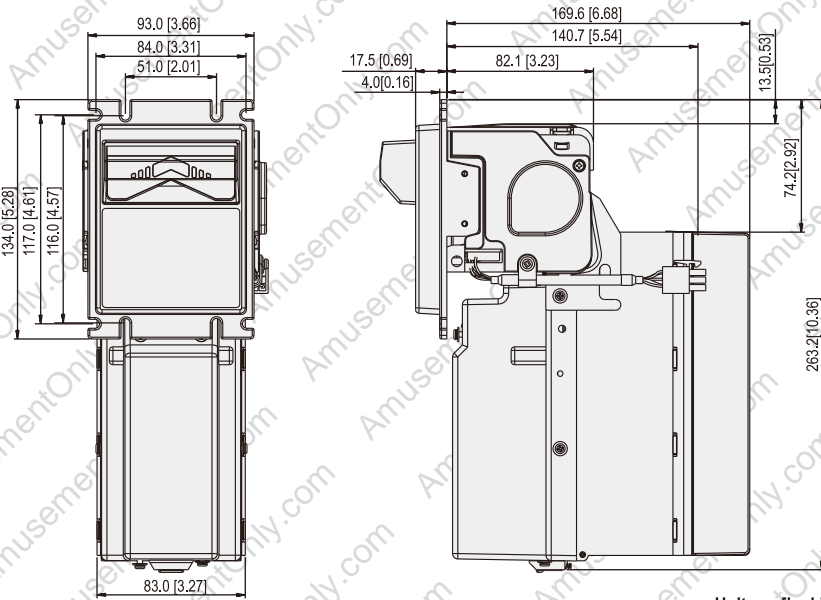

Unit:mm[inch]

4 FIG.04

L77F | Bezel (78mm)

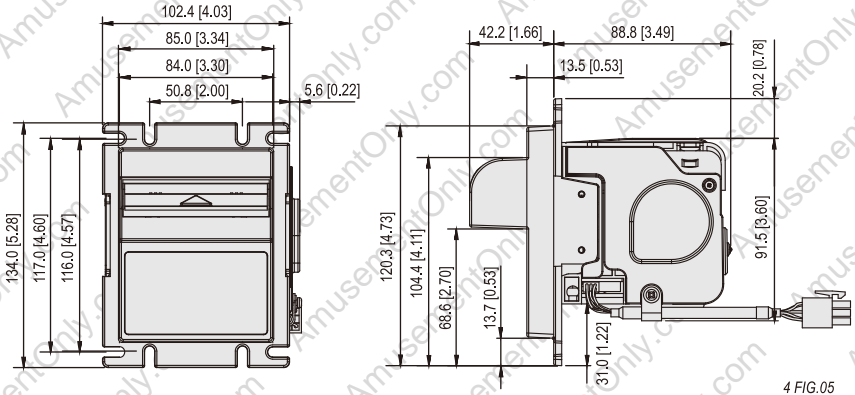

4 FIG.05

L77F-P2/P5 | Bezel (78mm)

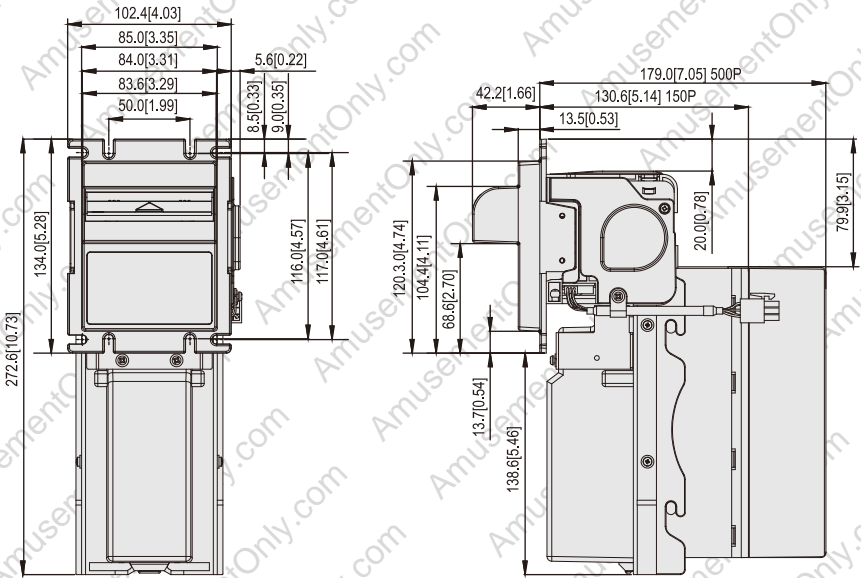

Unit:mm[inch]

4 FIG.06

**L83 E Type Bezel (83mm)**

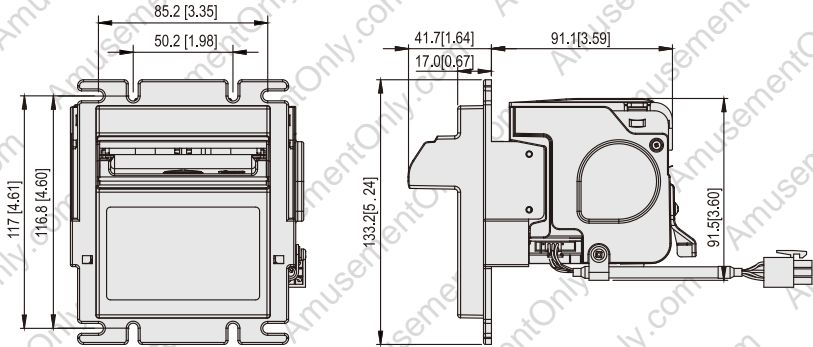

4 FIG.07

**L83-P3/P6 Down Stacker E Type Bezel (83mm)**

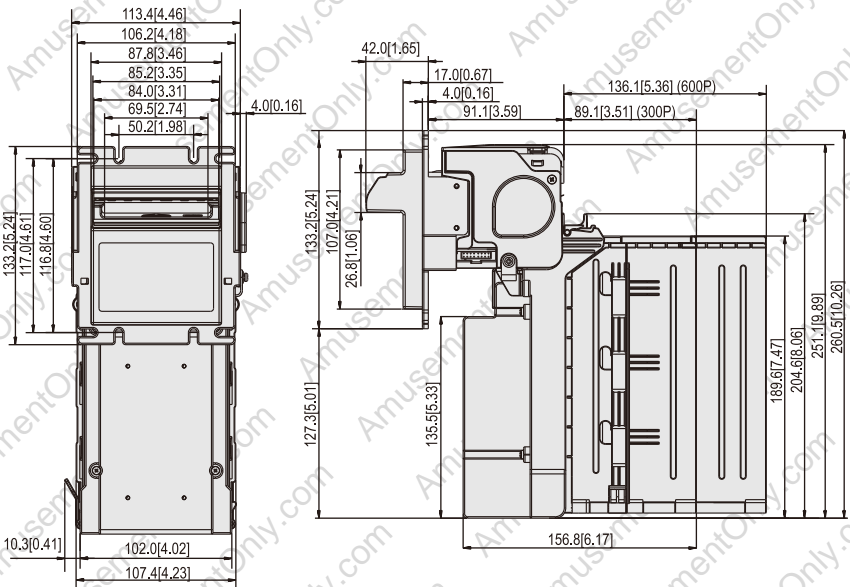

Unit:mm[inch]

4 FIG.08

**L83-P3/P6 Down Stacker F Type Bezel (83mm)**

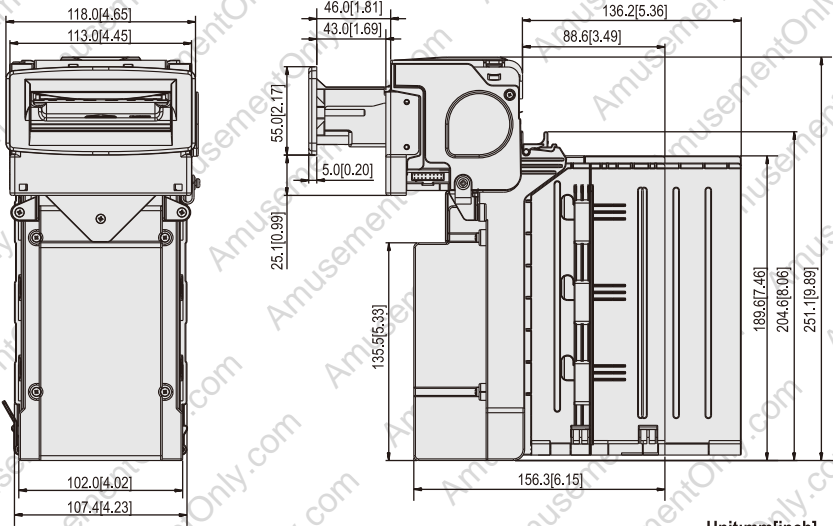

Unit:mm[inch]

4 FIG.09

**L83 Y Type Bezel (79mm)**

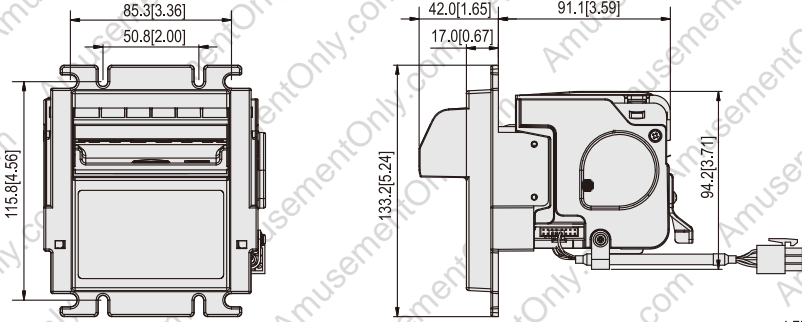

4 FIG.10

**L83-P3/P6 Down Stacker Y Type Bezel (79mm)**

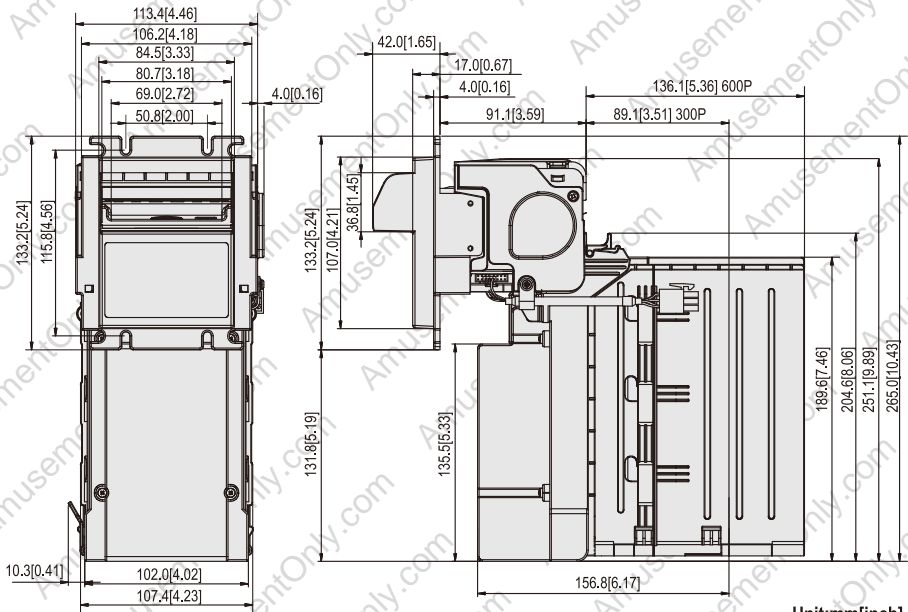

Unit:mm[inch]

4 FIG.11

L70T-P5, L77T-P5 <Without metal bracket>

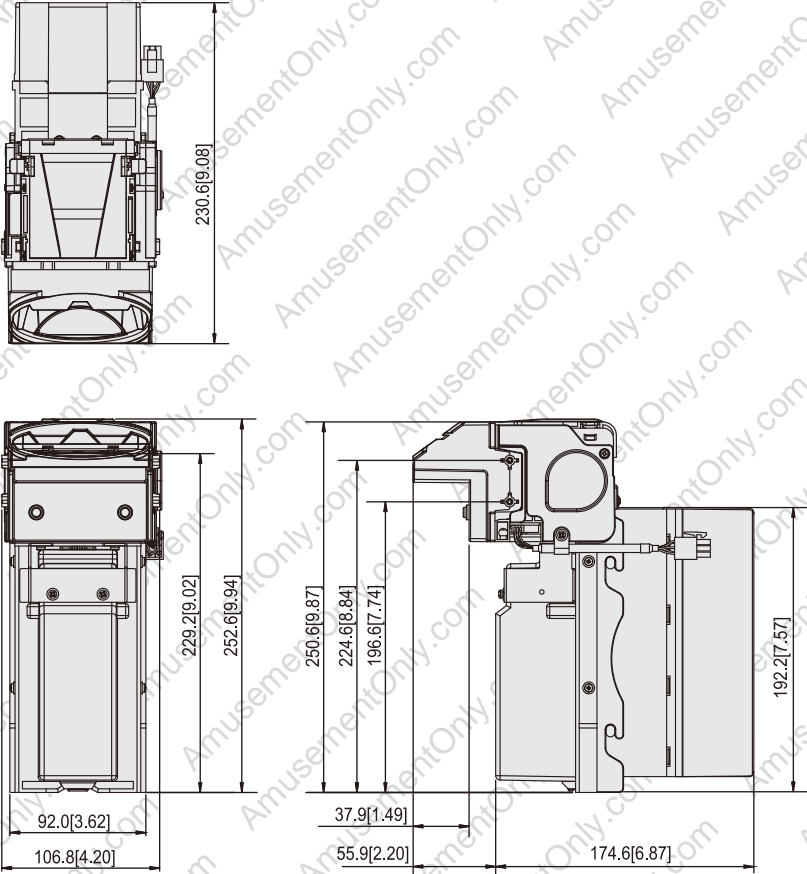

Unit:mm[inch]

4 FIG.12

**L70T-P5, L77T-P5 <With metal bracket>**

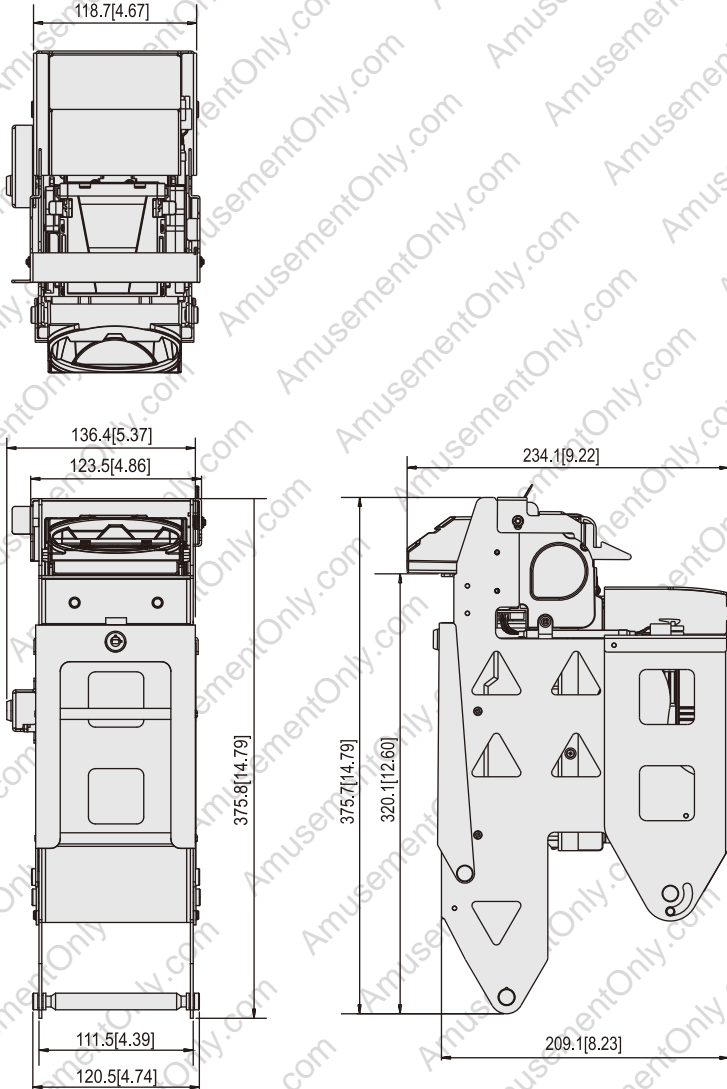

Unit:mm[inch]

4 FIG.13



To install the bill acceptor on your VMC, please be aware of the dimension as below:

[ L ] : Longer than the maximum length of accepted bills.

[ L1 ] : Bill box capacity depth.

\* [ L/2 ] has to be longer than 70mm to open upper base.

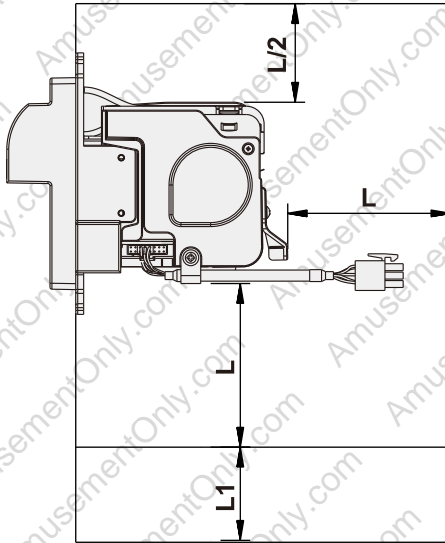

4 FIG.14

## 5. Installation

### 5-1. Harness Application

5-1 TABLE 01

Model	Interface	Used Voltage	Usage	Harnesses	Page	
<b>L70</b>	Pulse	12V DC	Power & *Data Comm. ★3	WEL-RL702	20	
			Extension Wire	CU-R961-1	19	
	ICT(RS232)	12V DC	Power & *Data Comm.	WEL-RL703 ★1	21	
	Parallel A1	12V DC	Power & *Data Comm.	WEL-RL701	20	
			Extension Wire	WEL-R061	23	
	RS232 A0	12V DC	Power & *Data Comm.	WEL-RL705-1	22	
			Extension Wire	WEL-RID04	23	
	ccTalk	12V DC	Power & *Data Comm. (BA↔Plug-in Board)	5RBA-RAB248MX		
	<b>L70# L70F L77F</b>	Pulse	12V DC	Power & *Data Comm.	WEL-R7U02	24
				Extension Wire	CU-R961-1	19
ICT (RS232)		12V DC	Power & *Data Comm.	WEL-R7U02	24	
			Extension Wire	CU-R961-1	19	
			*Data Comm.	WEL-R7U06-2 ★2 or 2-BA-R7U06	25	
ccNet compatible		12V DC	Power & *Data Comm.	WEL-R7U02	24	
			Extension Wire	CU-R961-1	19	
			*Data Comm.	WEL-R7U06-2 ★2 or 2-BA-R7U06	25	
RS232 A0		12V DC	Power & *Data Comm.	WEL-R7U02	24	
			Extension Wire	CU-R961-1	19	
			*Data Comm.	WEL-R7U06-2 ★2 or 2-BA-R7U06	25	
MDB		★4 34V DC	Power & *Data Comm. (BA↔Plug-in Board) ★5	WEL-RBG01	26	
			Power & *Data Comm.(35cm) (Plug-in Board↔VMC)	WEL-RBG08	27	
			Power & *Data Comm.(200cm) (Plug-in Board↔VMC)	WEL-RBG07	26	

★1. Maintenance use only.

★2. WEL-R7U06-2 : TTL Level to ±12VDC Level for PC.

★3. Data Comm. : Data Communication.

★4. MDB 34VDC : VMC Provides +34VDC to MDB Plug-in Board to convert into +12VDC, and provides +12VDC to L series bill acceptors.

★5. MDB Box : 5RBG-AA313NA0 For L70#, L70F, L77F, L70T, L77T, 5RBG-AA313NAA For L83, L83#.

Model	Interface	Used Voltage	Usage	Harnesses	Page
<b>L70#</b>	ccTalk	12V DC	Power & *Data Comm. ★3 (BA↔Plug-in Board)	5RBA-RAA248MX	
	ccTalk	12V DC	Power	WEL-R7U02	24
			*Data Comm.	3-BA-RL70#RS232-B	27
	Pulse	110V AC	Power & *Data Comm. (BA↔Plug-in Board)	5RBA-RAA315-L	29
				30	
<b>L70F</b> <b>L77F</b>	Pulse (Out of service)	12V DC	Power & *Data Comm.	WEL-RL826	36
			Extension Wire	CU-R961-1	19
	ccTalk	12V DC	Power & *Data Comm.	WEL-RL77F01	28
<b>L83</b>	Pulse	12V DC	Power & *Data Comm.	WEL-RL802	31
			Extension Wire	CU-R961-1	19
	ccTalk	12V DC	Power & *Data Comm.	WEL-RL803	32
				IDC-RA10400	38
				CNT-R7025	38
				WEL-RL824	34
	RS232 A1	12V DC	Power & *Data Comm.	WEL-RL805	33
	ICT (RS232)	12V DC	Power	WEL-RL802	31
			Extension Wire	CU-R961-1	19
			*Data Comm.	WEL-R7U06-2 ★2 or 2-BA-R7U06	25
	ccNet compatible	12V DC	Power	WEL-RL802	31
			Extension Wire	CU-R961-1	19
			*Data Comm.	WEL-R7U06-2 ★2 or 2-BA-R7U06	25
	MDB	34V DC ★4	Power & *Data Comm. ★5 (BA↔Plug-in Board)	WEL-RL812	34
			Power & *Data Comm.(35cm) (Plug-in Board↔VMC)	WEL-RBG08	27
Power & *Data Comm.(200cm) (Plug-in Board↔VMC)			WEL-RBG07	26	
RS232 A0	12V DC	Power	WEL-RL802	31	
		Extension Wire	CU-R961-1	19	
		*Data Comm.	WEL-R7U06-2 ★2 or 2-BA-R7U06	25	

★2. WEL-R7U06-2 : TTL Level to ±12VDC Level for PC.

★3. Data Comm. : Data Communication.

★4. MDB 34VDC : VMC Provides +34VDC to MDB Plug-in Board to convert into +12VDC, and provides +12VDC to L series bill acceptors.

★5. MDB Box : 5RBG-AA313NA0 For L70#, L70F, L77F, L70T, L77T, 5RBG-AA313NAA For L83, L83#.

5-1 TABLE 03

Model	Interface	Used Voltage	Usage	Harnesses	Page
<b>L83</b>	Parallel	12V DC	Power & *Data Comm. ★ <sup>3</sup>	WEL-RL804	32
	Parallel A4		Power & *Data Comm.	WEL-RL806	33
	Pulse(Out of service)		Power & *Data Comm.	WEL-RL825	35
			Extension Wire	CU-R961-1	19
<b>L83#</b>	Pulse	12V DC	Power & *Data Comm.	WEL-RL802	31
			Extension Wire	CU-R961-1	19
	ccTalk	12V DC	Power & *Data Comm.	WEL-RL803	32
				IDC-RA10400	38
				CNT-R7025	38
				WEL-RL824	34
	RS232 A1	12V DC	Power & *Data Comm	WEL-RL805	33
	ICT (RS232)	12V DC	Power	WEL-RL802	31
			Extension Wire	CU-R961-1	19
			*Data Comm.	WEL-R7U06-2 or 2-BA-R7U06	★ <sup>2</sup> 25
	ccNet compatible	12V DC	Power	WEL-RL802	31
			Extension Wire	CU-R961-1	19
			*Data Comm.	WEL-R7U06-2 ★ <sup>2</sup> or 2-BA-R7U06	25
	MDB	34V DC ★ <sup>4</sup>	Power & *Data Comm. ★ <sup>5</sup> (BA ↔ Plug-in Board)	WEL-RL812	34
			Power & *Data Comm.(35cm) (Plug-in Board ↔ VMC)	WEL-RBG08	27
			Power & *Data Comm.(200cm) (Plug-in Board ↔ VMC)	WEL-RBG07	26
	RS232 A0	12V DC	Power	WEL-RL802	31
			Extension Wire	CU-R961-1	19
			*Data Comm.	WEL-R7U06-2 ★ <sup>2</sup> or 2-BA-R7U06	25
	Pulse(Out of service)	12V DC	Power & *Data Comm.	WEL-RL825	35
Extension Wire			CU-R961-1	19	

★<sup>2</sup>. WEL-R7U06-2 : TTL Level to ±12VDC Level for PC.

★<sup>3</sup>. Data Comm. : Data Communication.

★<sup>4</sup>. MDB 34VDC : VMC Provides +34VDC to MDB Plug-in Board to convert into +12VDC, and provides +12VDC to L series bill acceptors.

★<sup>5</sup>. MDB Box : 5RBG-AA313NA0 For L70#, L70F, L77F, L70T, L77T, 5RBG-AA313NAA For L83, L83#.

Model	Interface	Used Voltage	Usage	Harnesses	Page
<b>L70T</b>  <b>L77T</b>	Pulse	12V DC	Power & *Data Comm. <b>★3</b>	WEL-R7U02	24
			Extension Wire	CU-R961-1	19
	ICT (RS232)	12V DC	Power & *Data Comm.	WEL-R7U02	24
			Extension Wire	CU-R961-1	19
			*Data Comm.	WEL-R7U06-2 <b>★2</b> or 2-BA-R7U06	25
	ccNet compatible	12V DC	Power & *Data Comm.	WEL-R7U02	24
			Extension Wire	CU-R961-1	19
			*Data Comm.	WEL-R7U06-2 <b>★2</b> or 2-BA-R7U06	25
	MDB	<b>★4</b> 34V DC	Power & *Data Comm. (BA↔Plug-in Board) <b>★5</b>	WEL-RBG01	26
			Power & *Data Comm.(35cm) (Plug-in Board↔VMC)	WEL-RBG08	27
			Power & *Data Comm.(200cm) (Plug-in Board↔VMC)	WEL-RBG07	26
	Pulse (Out of service)	12V DC	Power & *Data Comm.	WEL-RL826	36
			Extension Wire	CU-R961-1	19
	RS232 A0	24V DC	Power & *Data Comm.	3BA-RAA318-NX-0X	37
	V2.2				37
	ccTalk	12V DC	Power & *Data Comm.	WEL-RL77F01	28

★2. WEL-R7U06-2 : TTL Level to ±12VDC Level for PC.

★3. Data Comm. : Data Communication.

★4. MDB 34VDC : VMC Provides +34VDC to MDB Plug-in Board to convert into +12VDC, and provides +12VDC to L series bill acceptors.

★5. MDB Box : 5RBG-AA313NA0 For L70#, L70F, L77F, L70T, L77T, 5RBG-AA313NAA For L83, L83#.

5-1 FIG. 01

Interface	Used Voltage	Usage
Pulse	12V DC	Extension Wire for WEL-RL702
Pulse	12V DC	
ICT(RS232)	12V DC	Extension Wire for WEL-R7U02
ccNet compatible	12V DC	
RS232 A0	12V DC	
Pulse	12V DC	Extension Wire for WEL-RL802
ICT(RS232)	12V DC	
ccNet compatible	12V DC	
Pulse(Out of service)	12V DC	Extension Wire for WEL-RL825
Pulse(Out of service)	12V DC	Extension Wire for WEL-RL826

### CU-R961-1

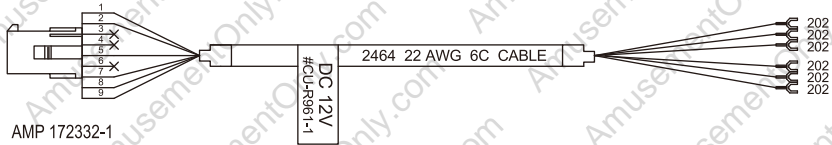

AMP 172332-1

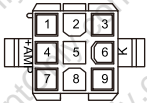

AMP 172332-1  
BACK VIEW

- PIN 1- YELLOW.....INHIBIT+
- PIN 2- GREEN.....INHIBIT-
- PIN 5- RED.....+12VDC(POWER-IN)
- PIN 7- BLUE.....CREOIT-RELAY-NO
- PIN 8- PURPLE.....CREDIT-RELAY-COM
- PIN 9- ORANGE.....GND(POWER-IN)

5-1 FIG.02

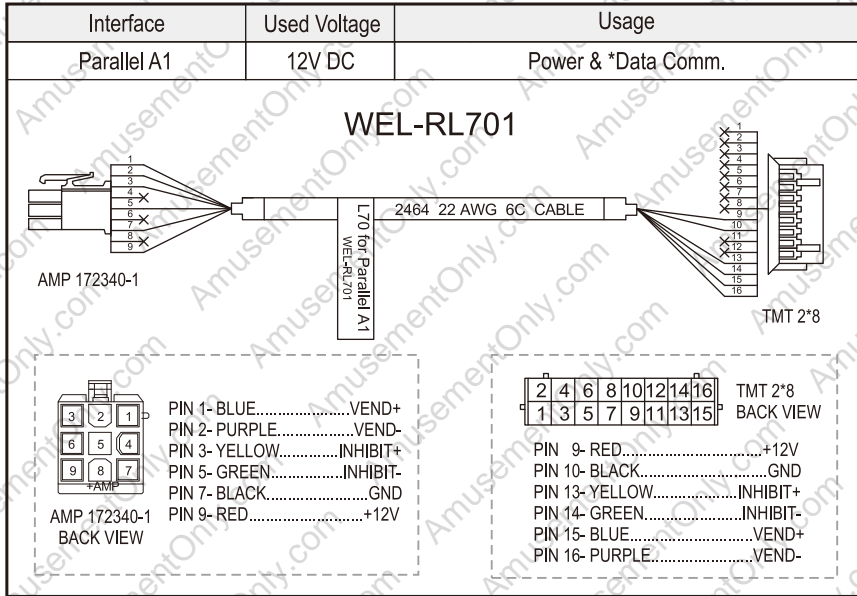

5-1 FIG.03

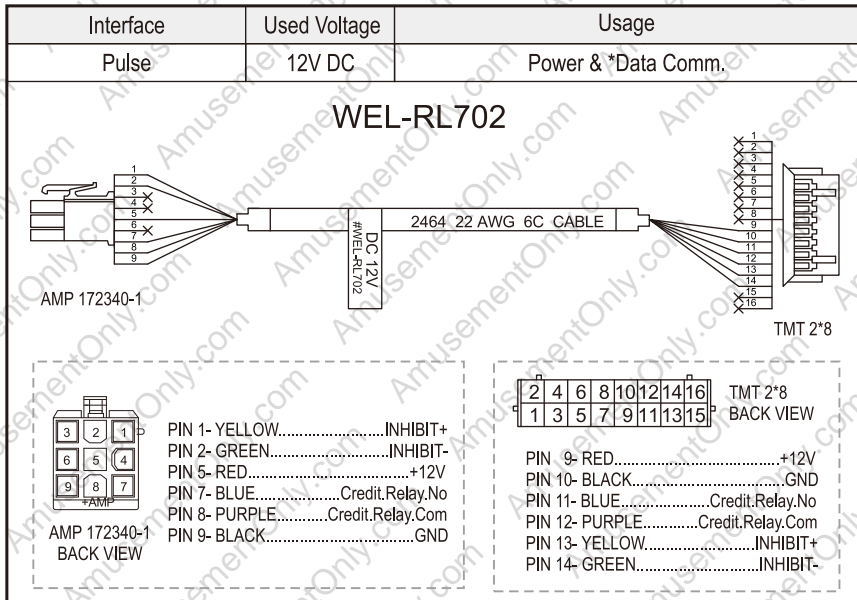

5-1 FIG.04

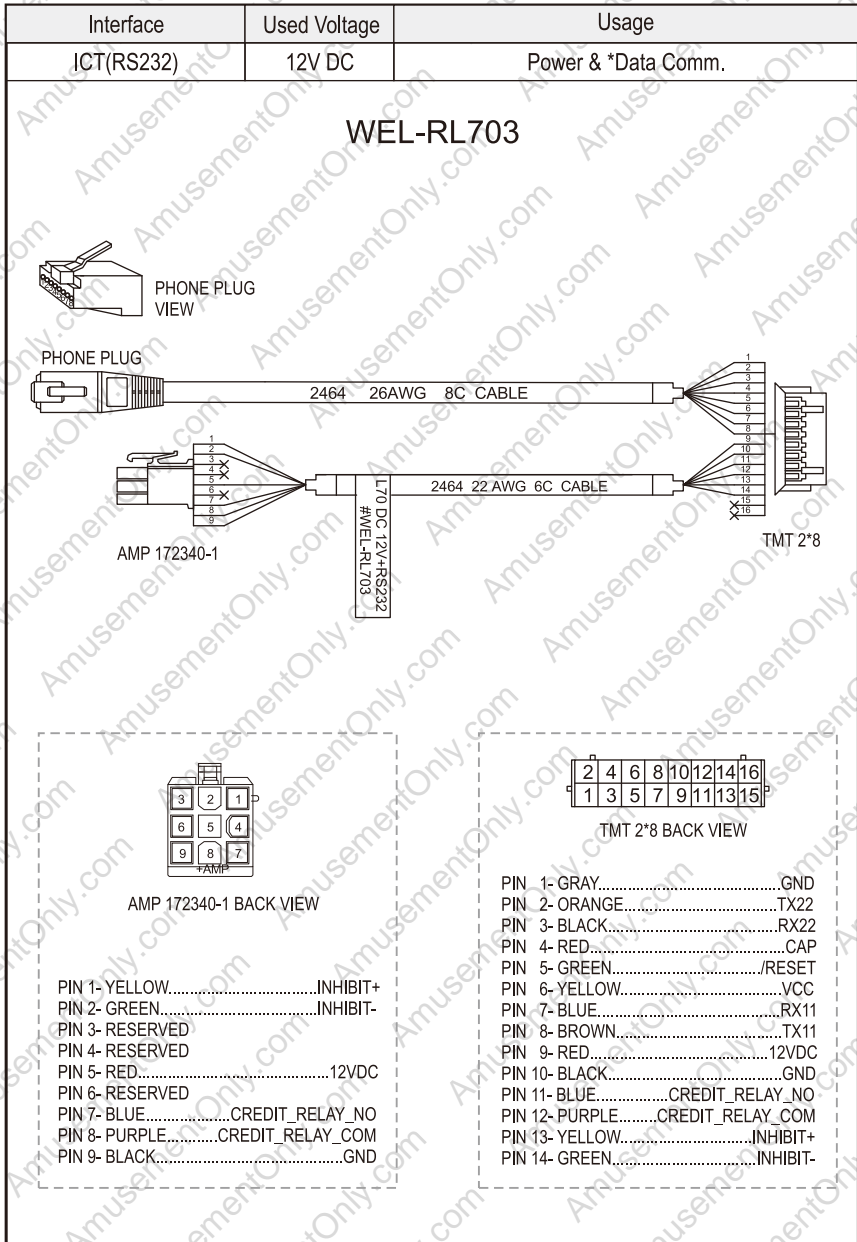

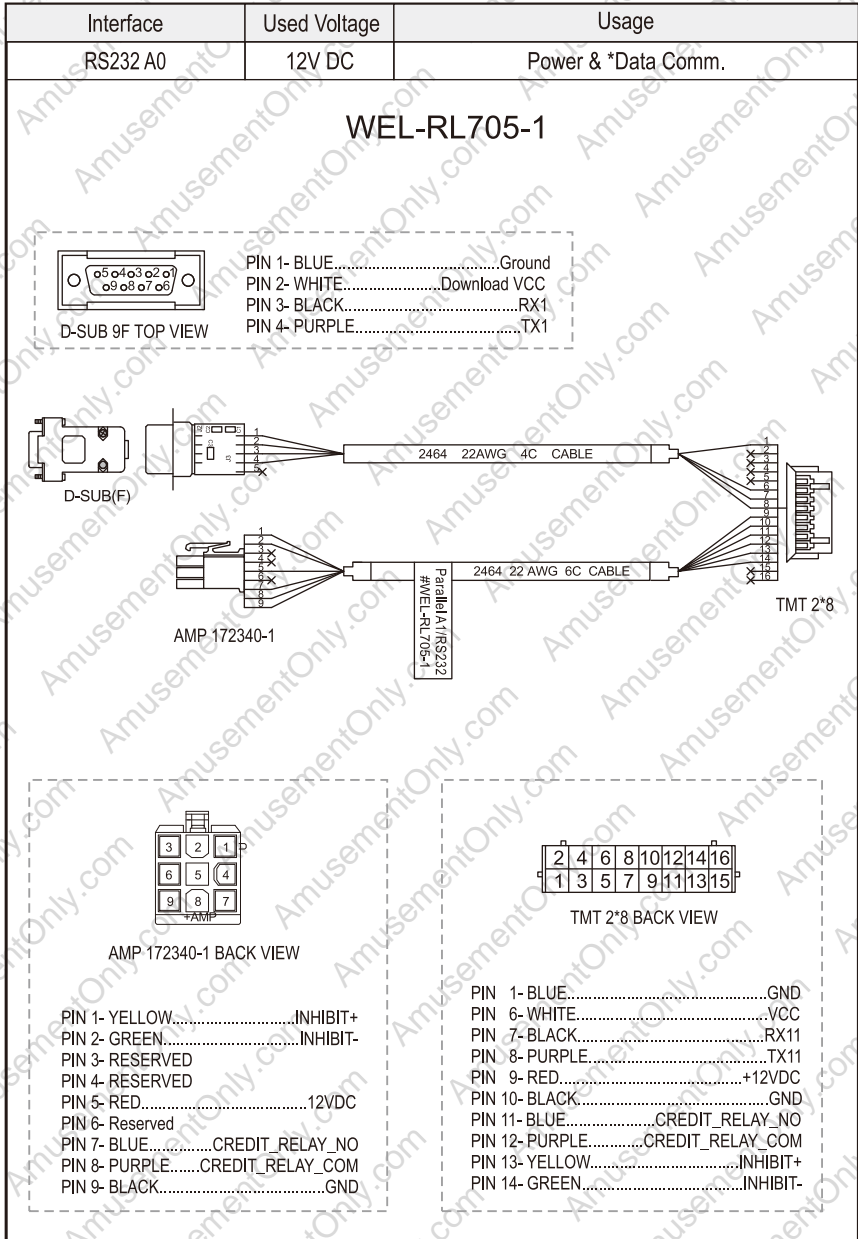

5-1 FIG.06

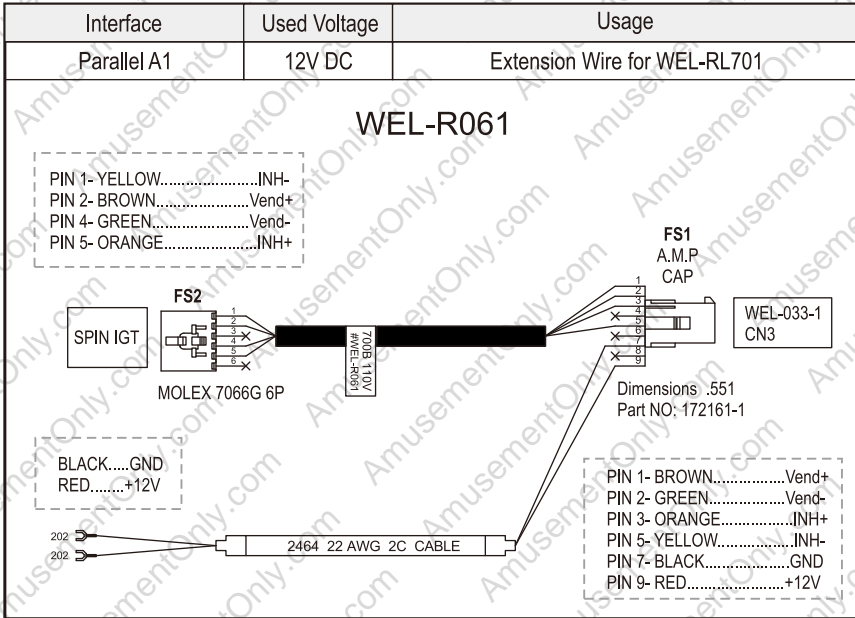

5-1 FIG.07

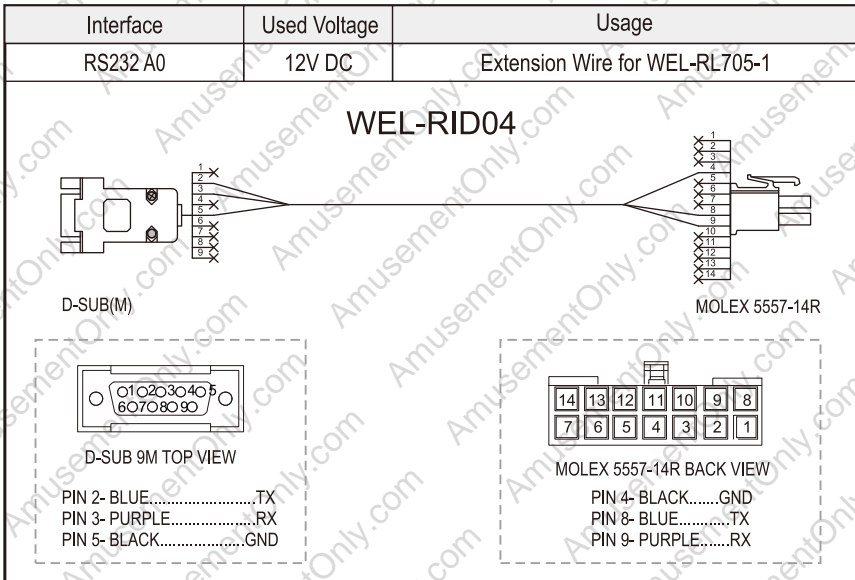

Interface	Used Voltage	Usage
Pulse	12V DC	Power & *Data Comm.
ICT(RS232)	12V DC	Power
ccNet compatible	12V DC	Power
RS232 A0	12V DC	Power
ccTalk	12V DC	Power

**WEL-R7U02**

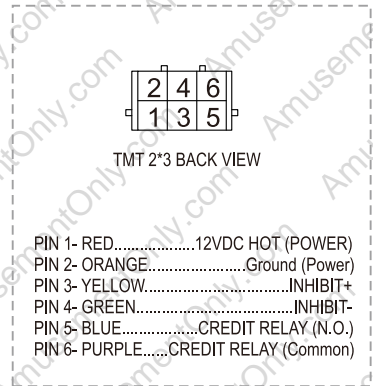
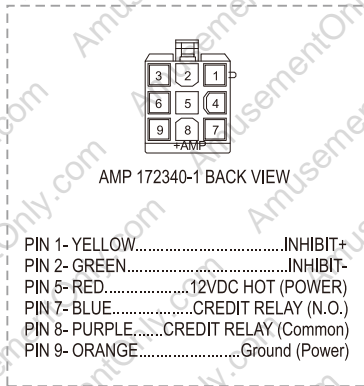
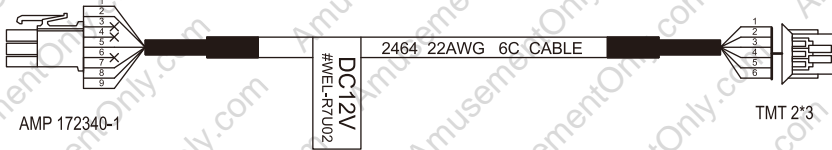

5-1 FIG.09

Interface	Used Voltage	Usage
ICT(RS232)	12V DC	*Data Comm.
ccNet compatible	12V DC	*Data Comm.
RS232 A0	12V DC	*Data Comm.

**WEL-R7U06-2**

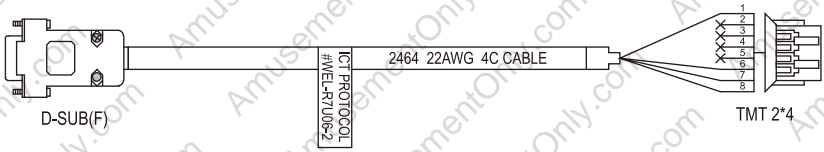

**2-BA-R7U06**

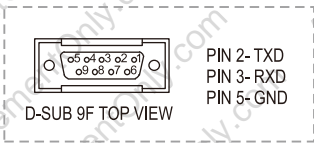
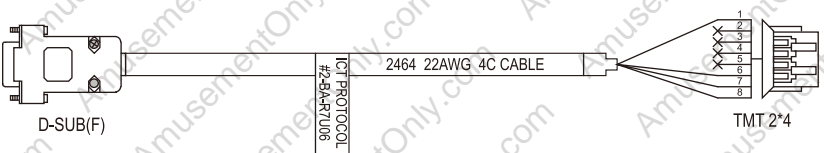

PIN 2- TXD  
 PIN 3- RXD  
 PIN 5- GND



PIN 1- BLUE.....Ground  
 PIN 6- WHITE.....Download VCC  
 PIN 7- BLACK.....RX1  
 PIN 8- PURPLE.....TX1

5-1 FIG.10

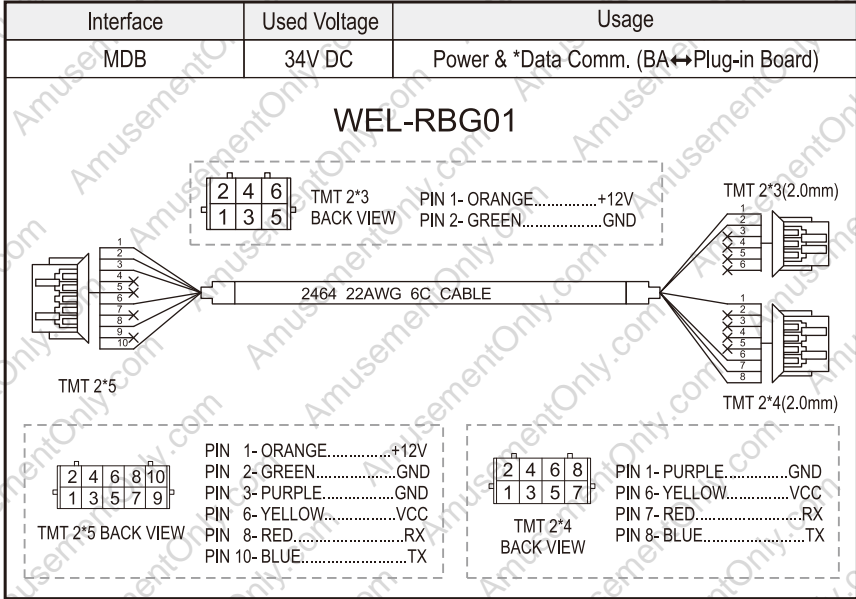

5-1 FIG.11

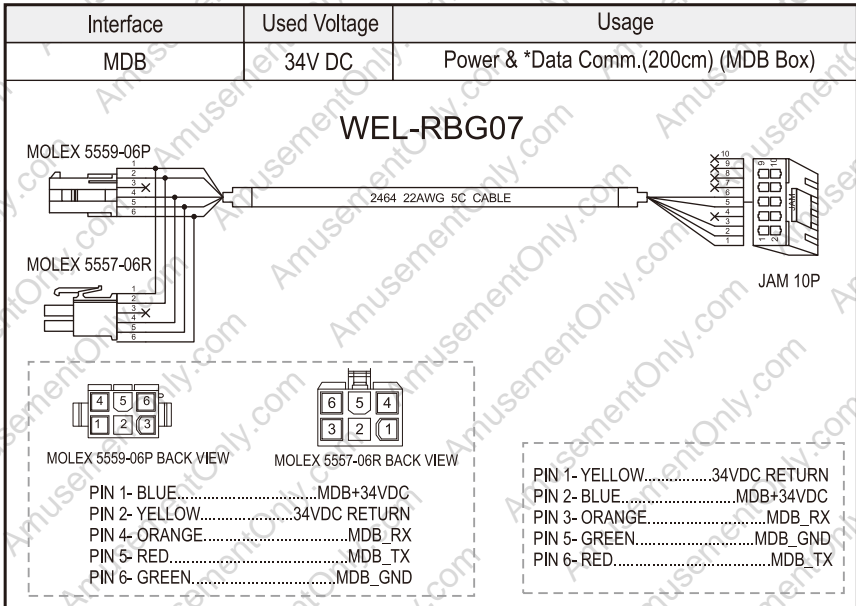

5-1 FIG.12

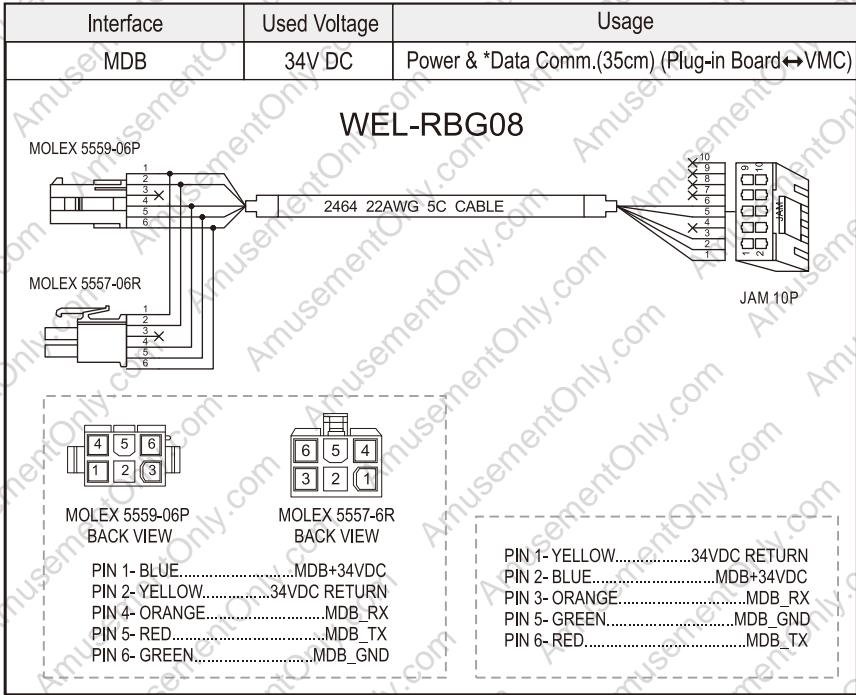

5-1 FIG.13

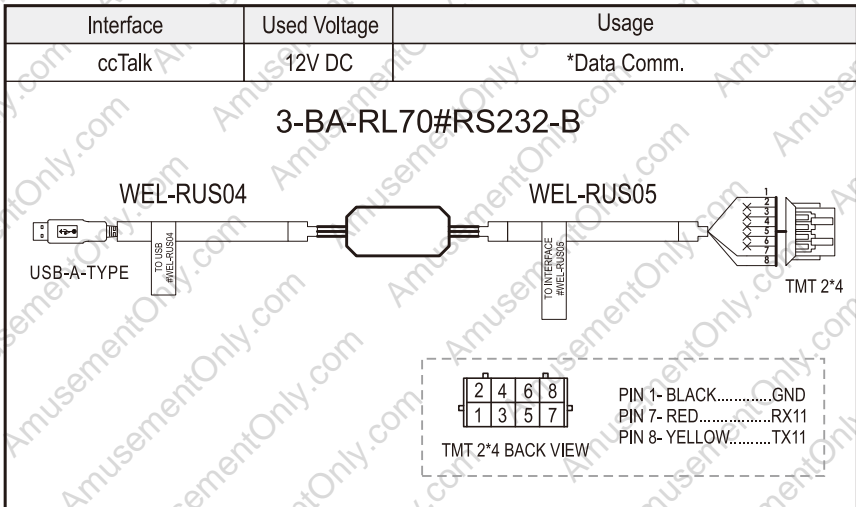

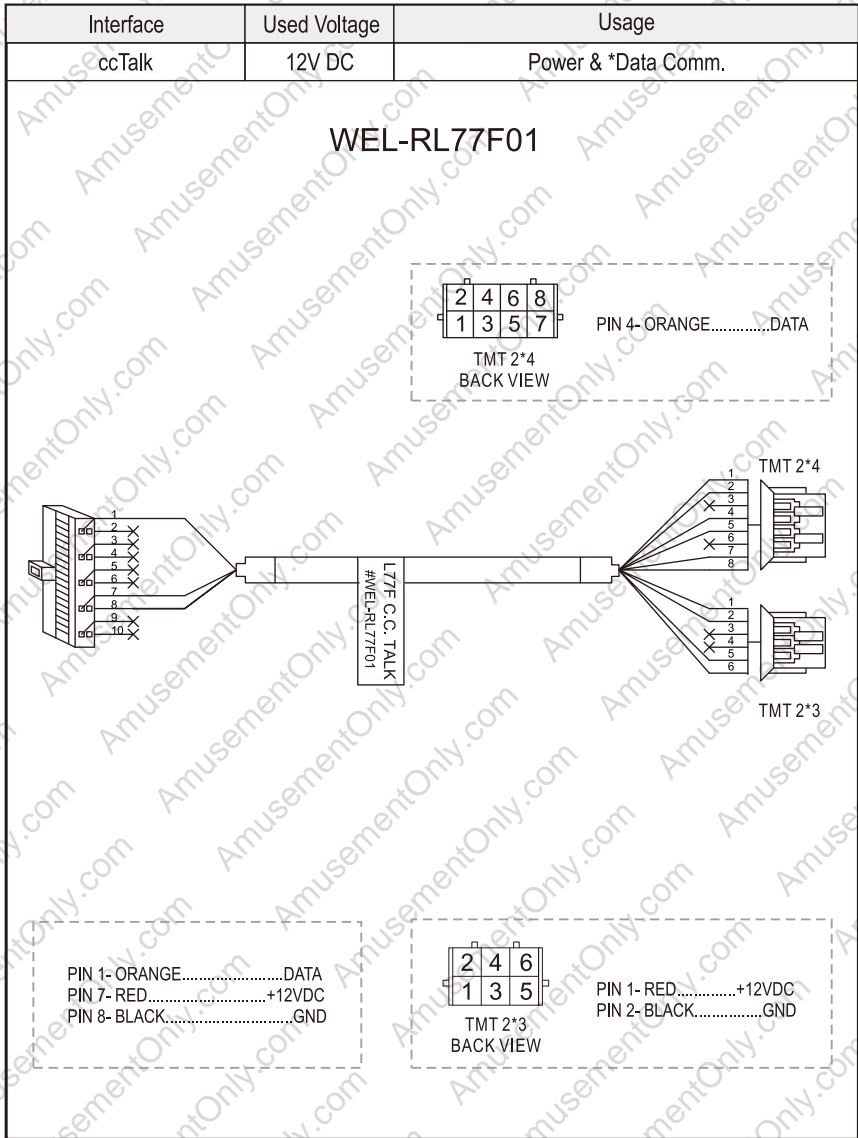

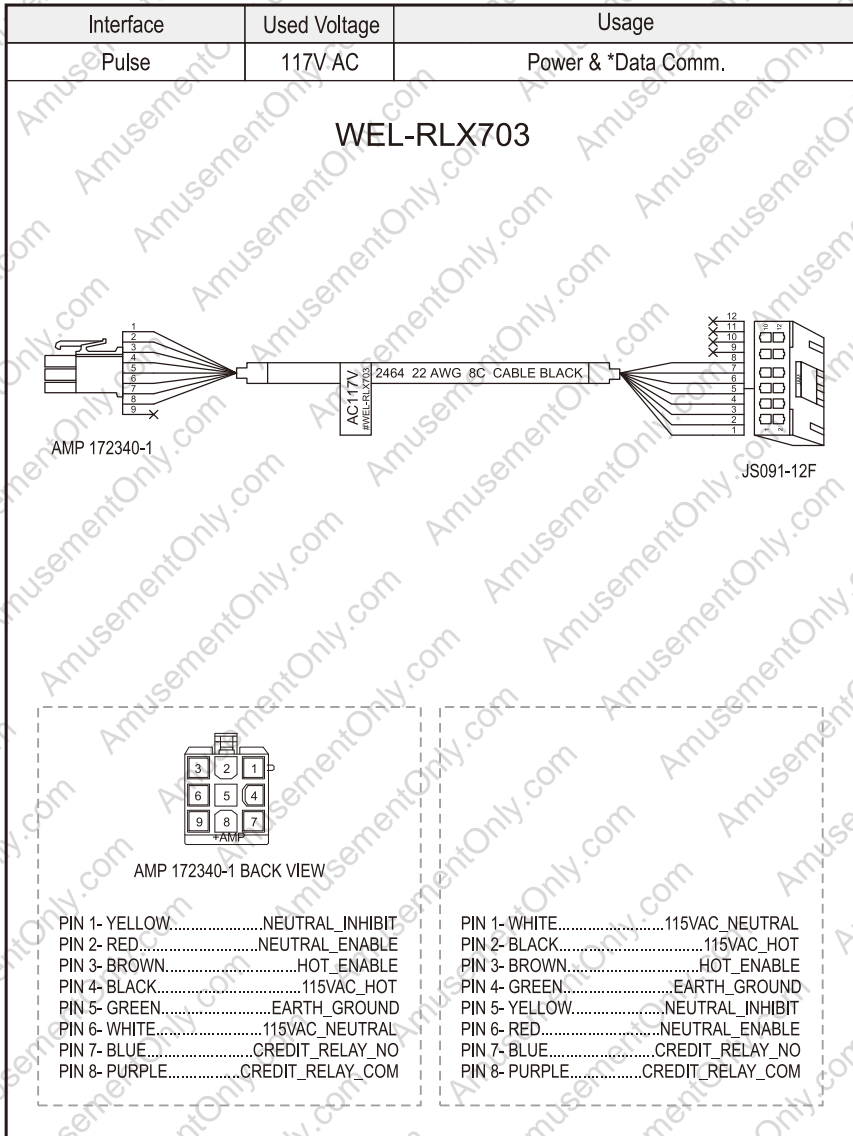

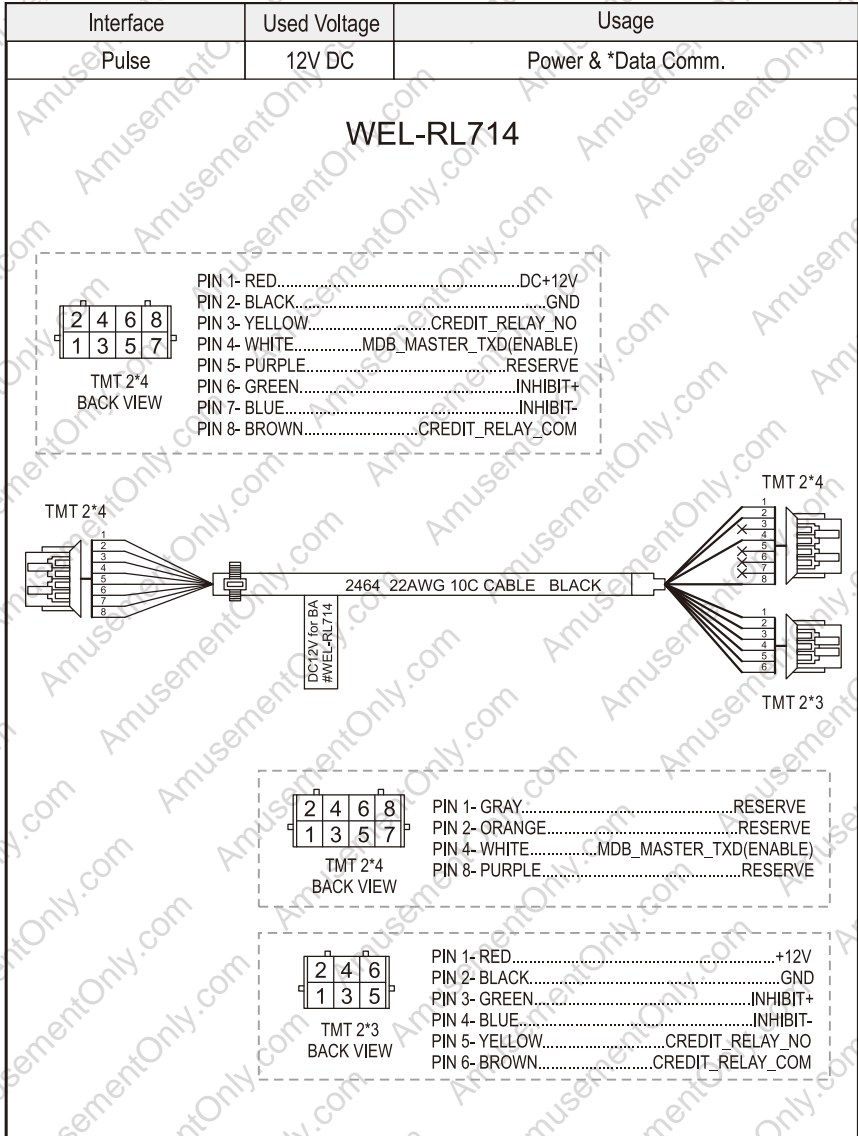

5-1 FIG.17

Interface	Used Voltage	Usage
Pulse	12V DC	Power & *Data Comm.
ccNet compatible	12V DC	Power
ICT(RS232)	12V DC	Power

### WEL-RL802

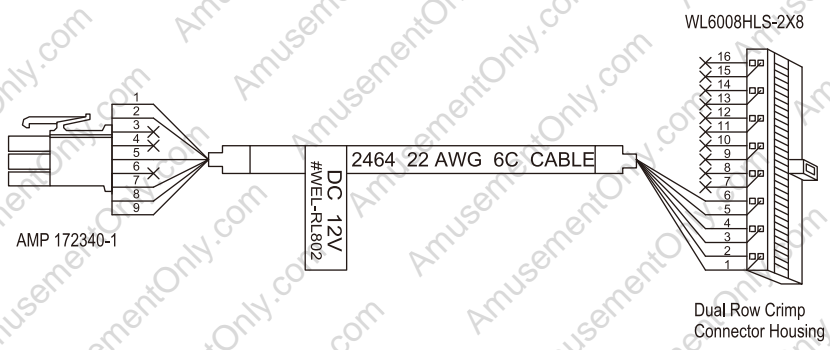

**AMP 172340-1 BACK VIEW**

PIN 1- YELLOW.....INHIBIT+  
 PIN 2- GREEN.....INHIBIT-  
 PIN 5- RED.....+12VDC  
 PIN 7- BLUE.....CREDIT RELAY NO  
 PIN 8- PURPLE.....CREDIT RELAY COM  
 PIN 9- BROWN.....GND

**TMT 2\*8 BACK VIEW**

PIN 1- RED.....+12VDC  
 PIN 2- BROWN.....GND  
 PIN 3- BLUE.....CREDIT RELAY NO  
 PIN 4- PURPLE.....CREDIT RELAY COM  
 PIN 5- YELLOW.....INHIBIT+  
 PIN 6- GREEN.....INHIBIT-

5-1 FIG. 18

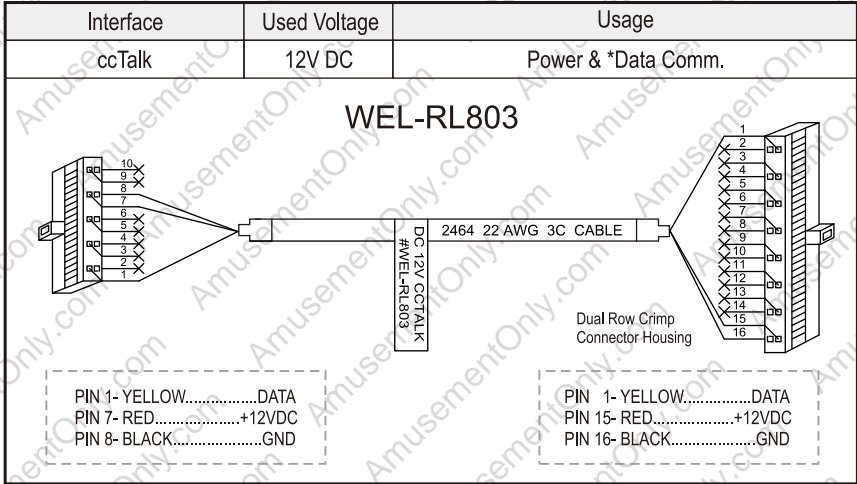

5-1 FIG. 19

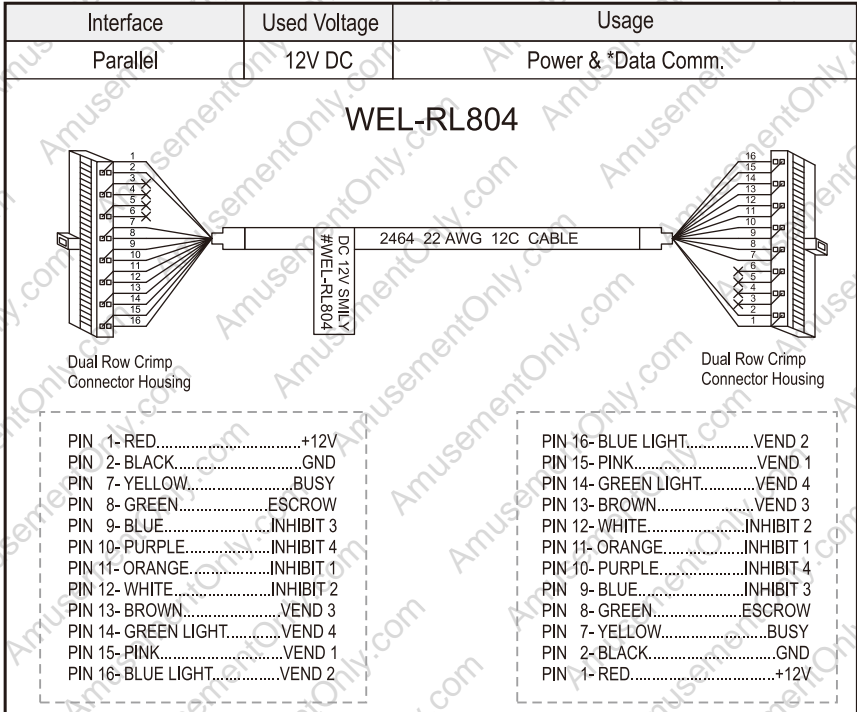



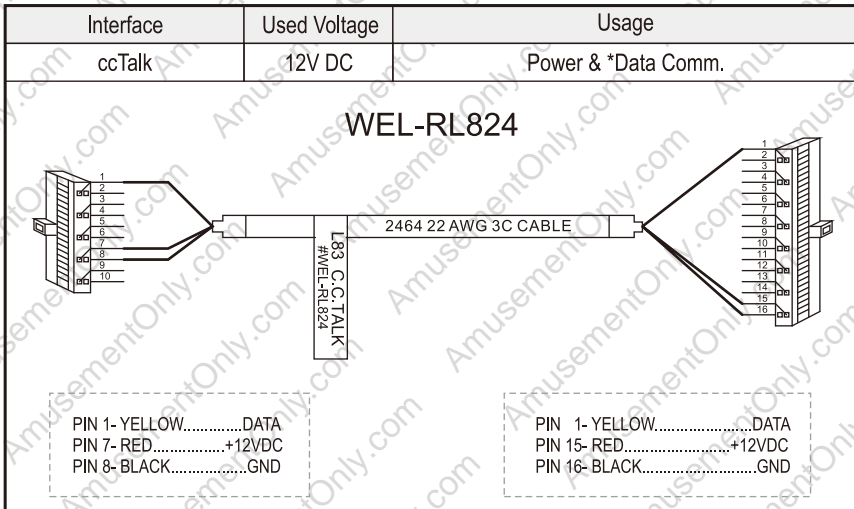
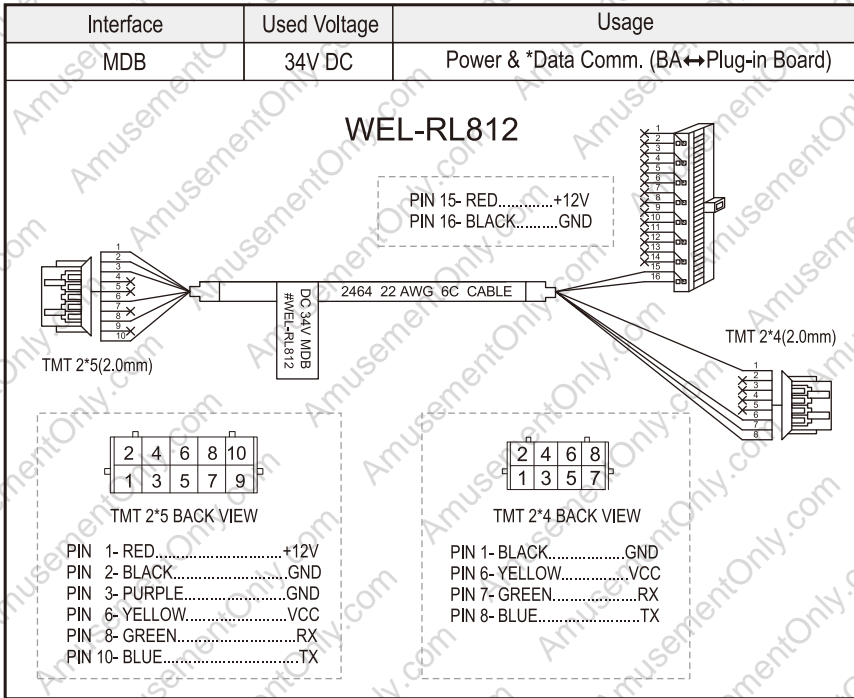

5-1 FIG.24

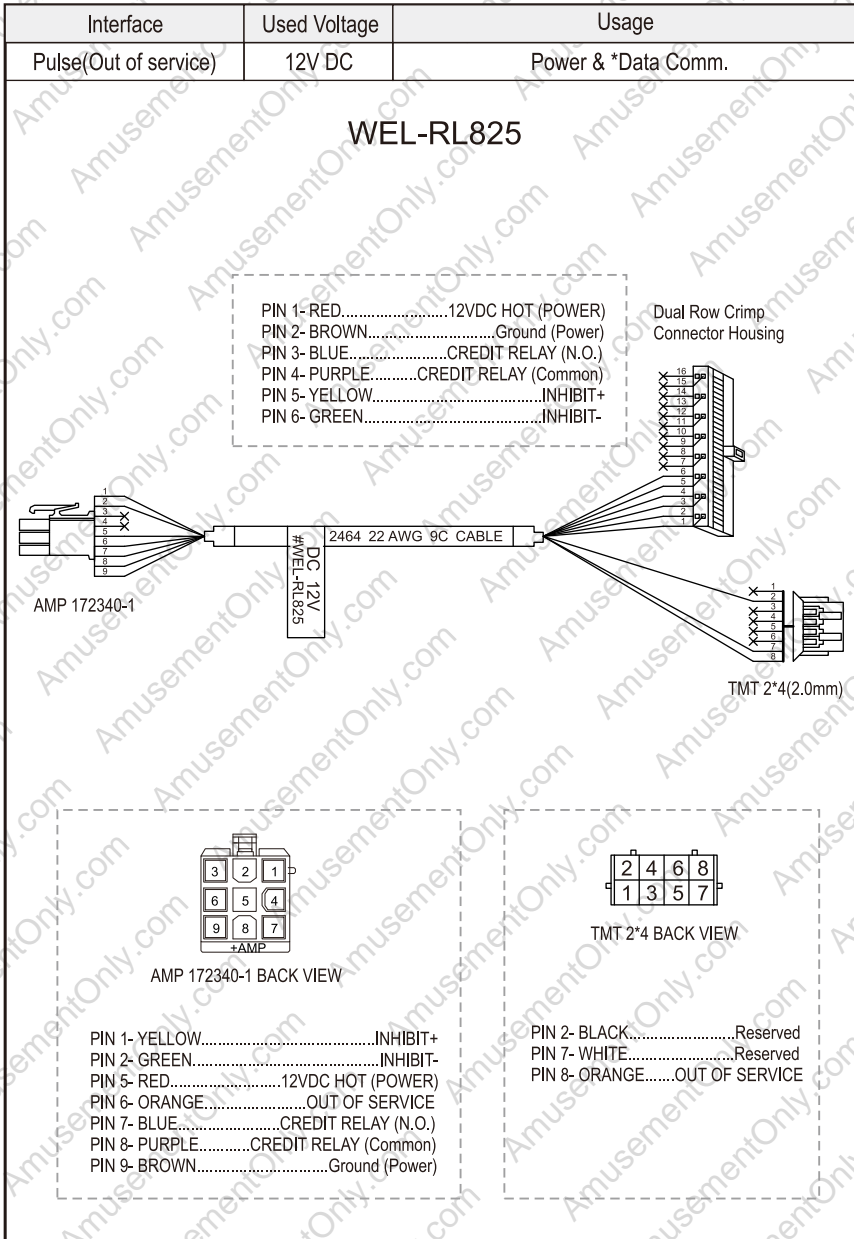

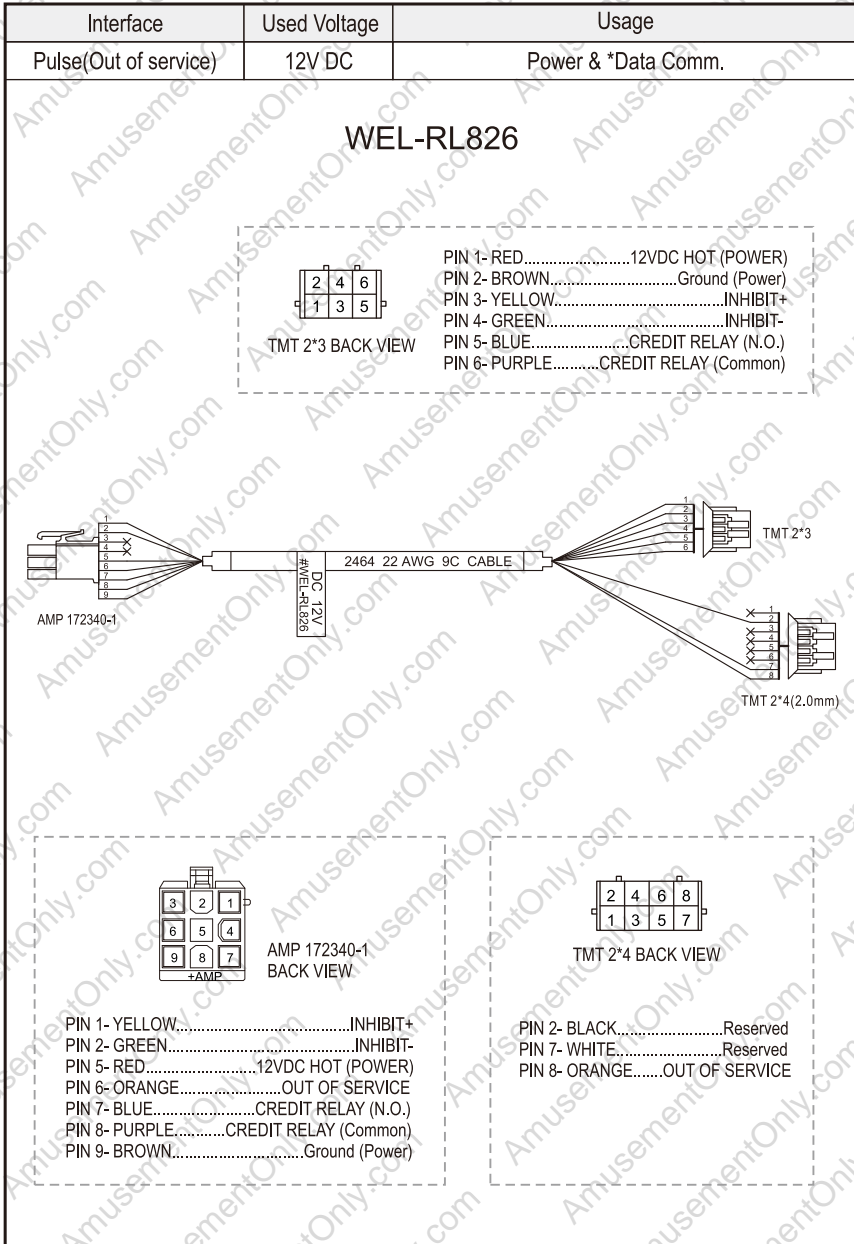

Interface	Used Voltage	Usage
RS232 A0	24V DC	Power & *Data Comm.
V2.2	24V DC	Power & *Data Comm.

### 3BA-RAA318-NX-0X

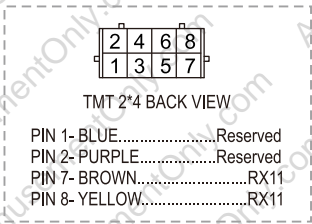
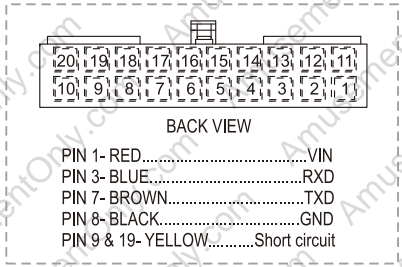
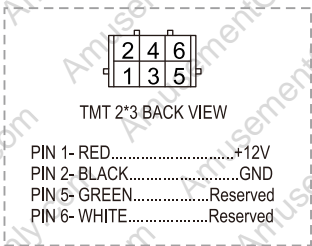
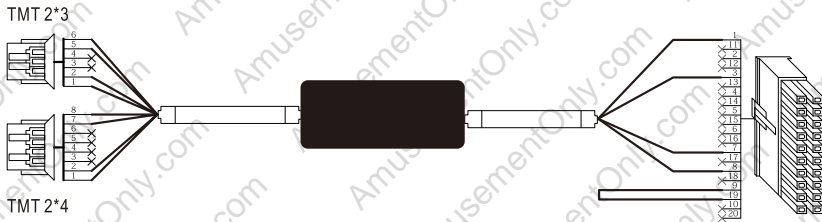

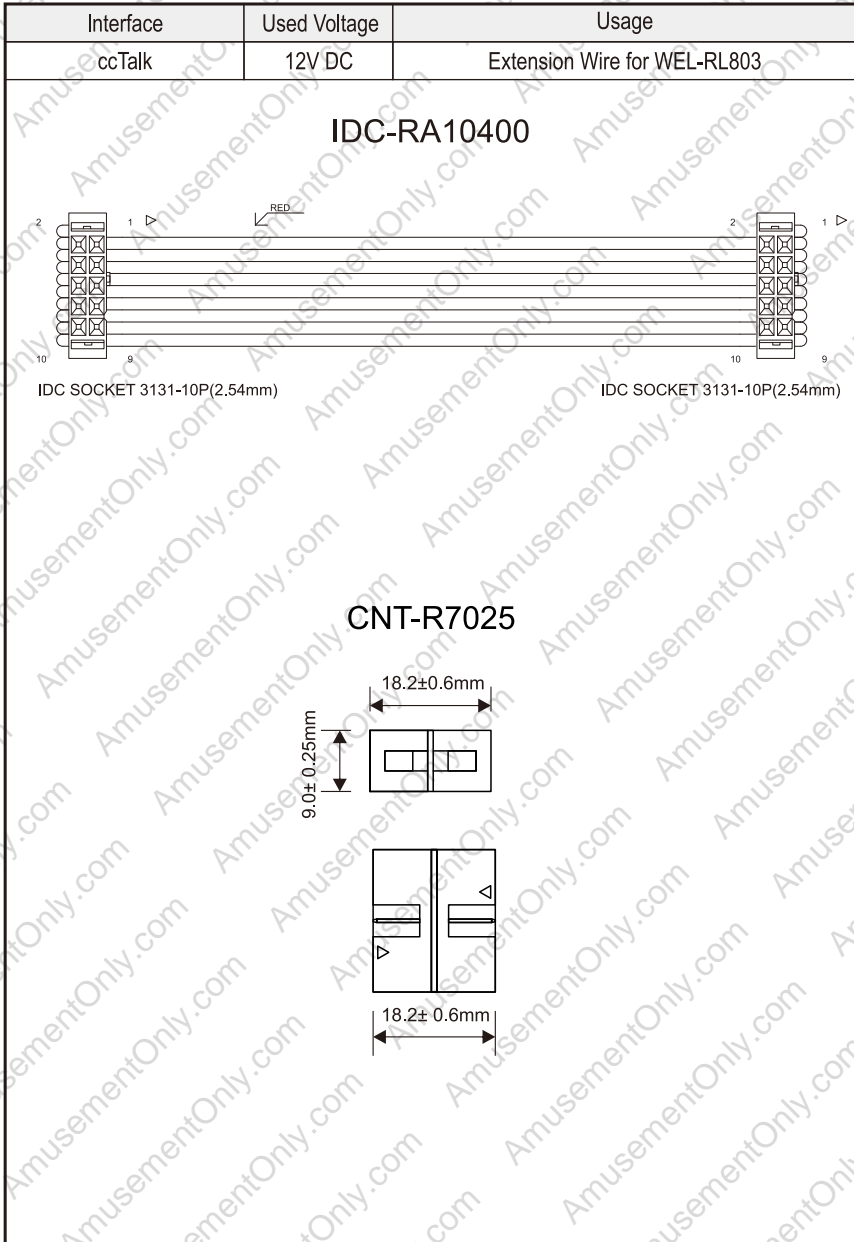

### 5-1-1. I/O Circuit Pulse Interface.

5-1-1 FIG. 01

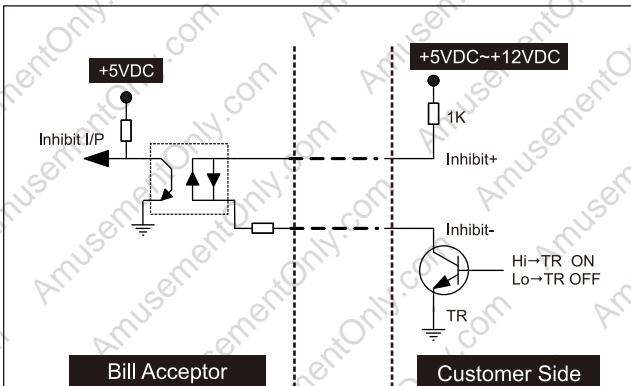
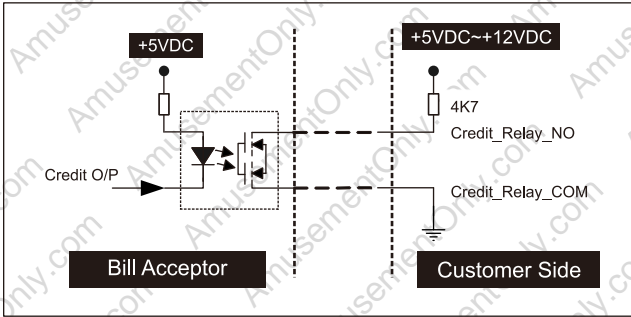

BA Status	*DIP SW Setting	Control Signal	
Inhibit	Inhibit Active	Low	Low
		High	High
Enable	Inhibit Active	Low	High
		High	Low

\*Note: Please refer to DIP Switch Setting Guide for detail.

RS232, RS232 A0, RS232 A1, ccNet compatible Interface.

5-1-1 FIG. 02

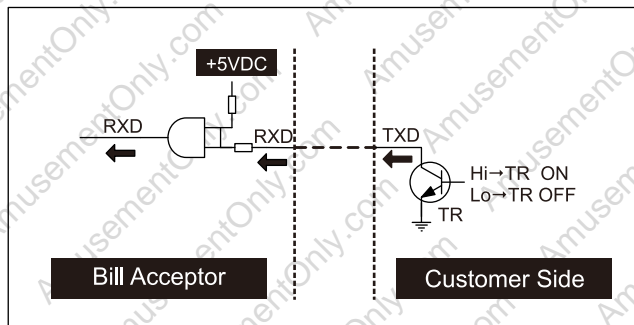
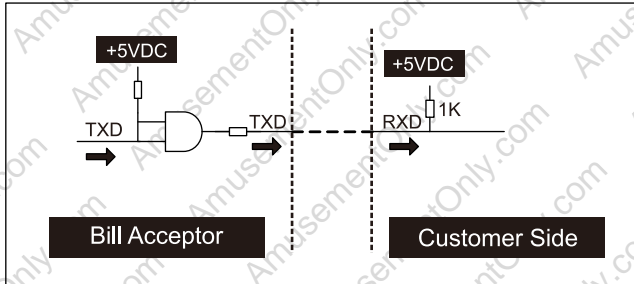

**MDB Interface.**

5-1-1 FIG. 03

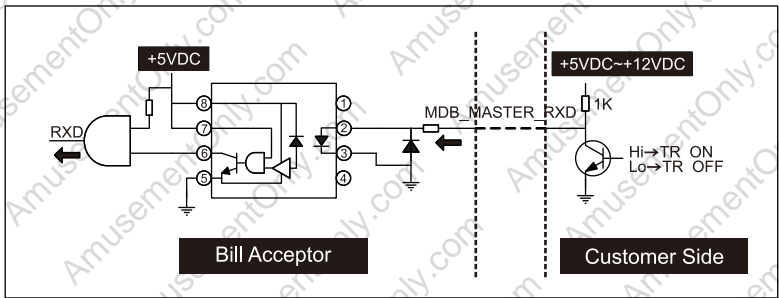
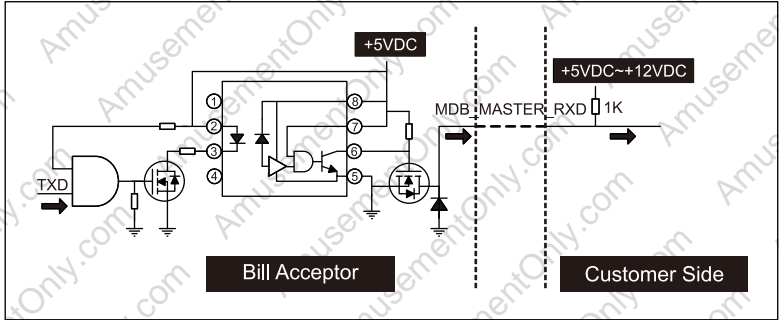

**Parallel A1 Interface.**

5-1-1 FIG. 04

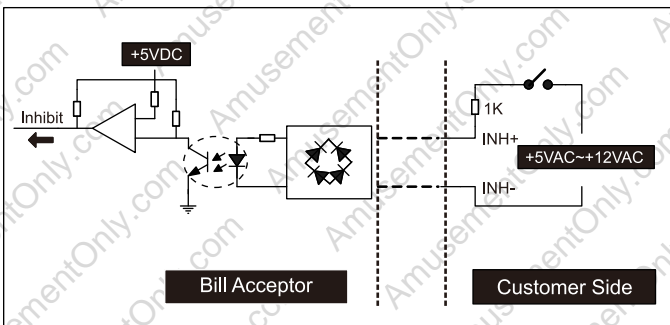
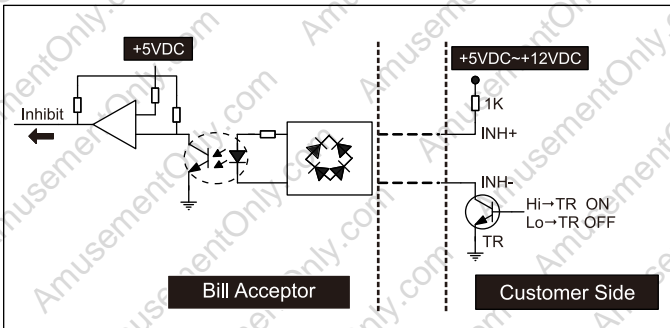
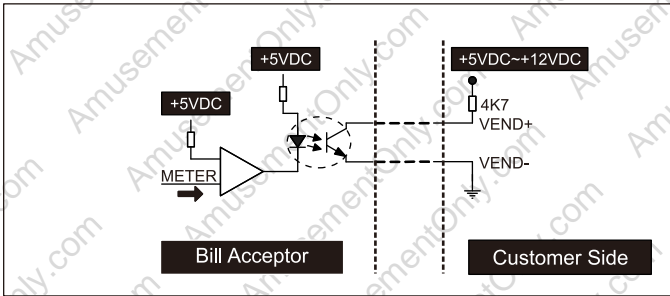

Parallel Interface.

5-1-1 FIG. 05

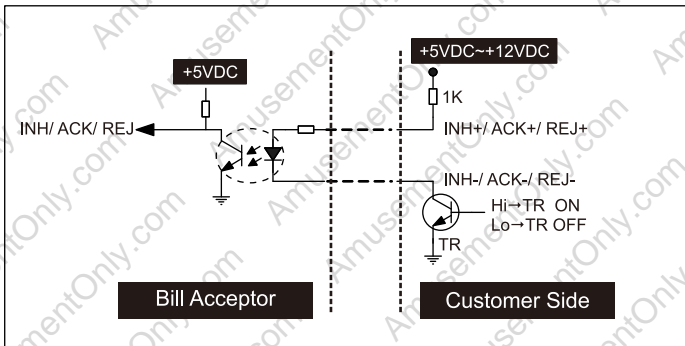
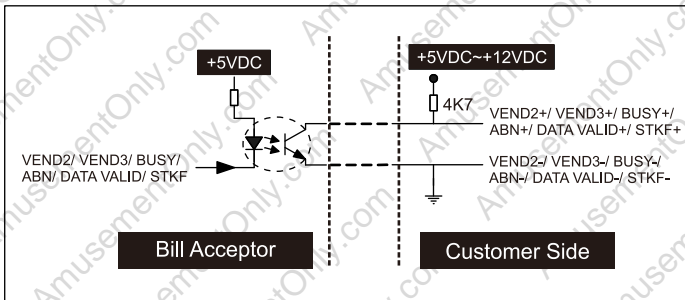
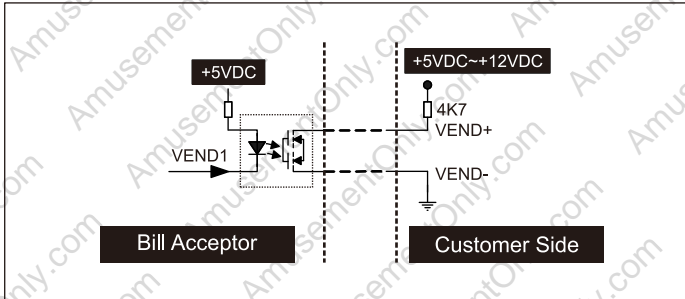

ccTalk Interface.

5-1-1 FIG. 06

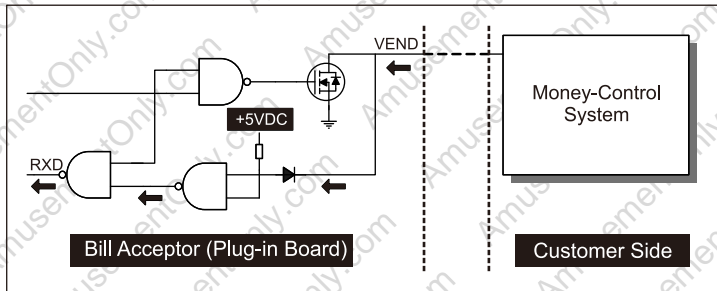
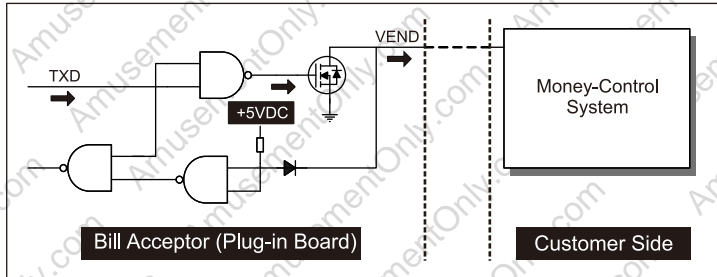

**L70T-P5, L77T-P5:**  
RS232 A0 & V2.2 Interface.

5-1-1 FIG. 07

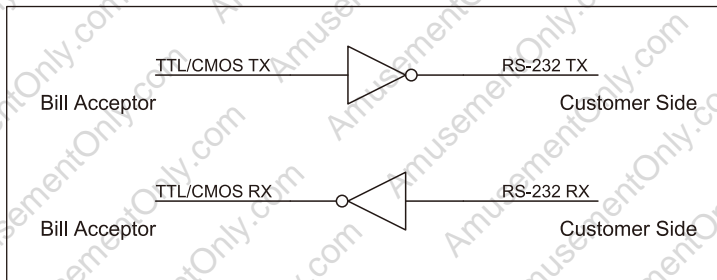

## 5-2. DIP Switch Setting

There is one serial DIP switches which are set on the side of L Series(as FIG.01). According to different currencies which are used by users, DIP switch settings could be varied to fit users' needs. Besides, there's another serial DIP switches at the bottom of L series for interface setting(as FIG.02). Please refer to " L Series DIP Switch Setting Guide " in the package for more details.

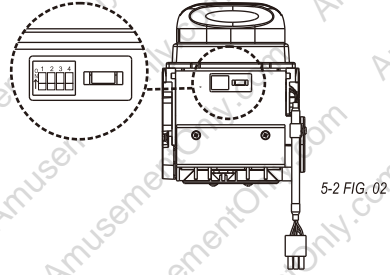
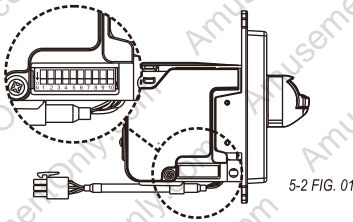

## 5-3. Software Download and Upgrade

To download and upgrade the software to L Series, the programmer (FP-004) is needed. Please contact ICT to purchase(FP-004) and refer to FP-004 user guide for software download and upgrade information.

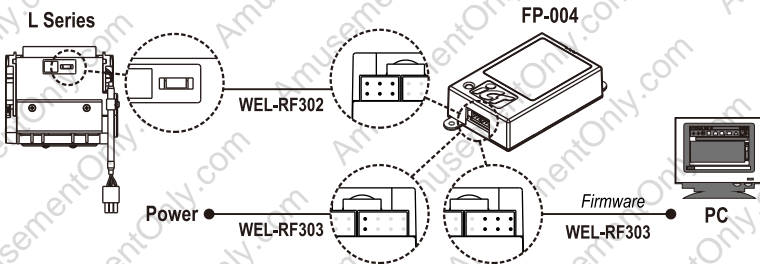

Turn on Bill Acceptor after connecting.

## 6. Maintenance

To make sure the bill acceptor always works smoothly, please clean the internal parts regularly.

To clean the internal parts:

1. Turn bill acceptor off.
2. Press buttons to open LED assembly.
3. Use soft cloth or cotton swab to clean internal parts and bill path.

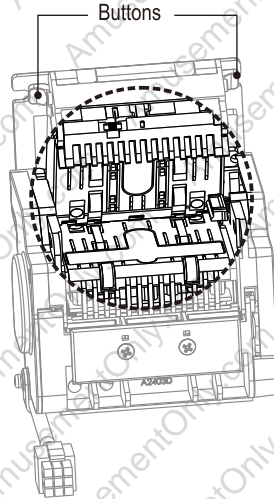

6 FIG. 01



### Maintenance Notice

*(Any improper maintenance will result invalid warranty.)*

**Recommended**

**Mild, non-abrasive, soap water.**

**DO NOT USE**

**Organic solvent , Alcohol, Volatile liquid.**

## 7. Troubleshooting

### Bezel LED Errors

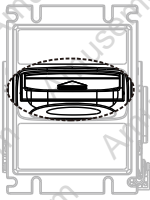

7 FIG. 01

L70#

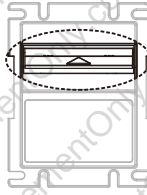

7 FIG. 02

L77F

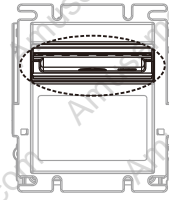

7 FIG. 03

L83

7 TABLE 01

LED Flashes		Status	Corrective Actions
Red	Green		
	1	White Card Calibration	Please calibrate with ICT white calibration card.
1		Bill jammed.	Open bill path unit and then remove the jammed bill.
2		Disable.	Inspect the right DIP switch setting.
3		Recognition sensor module error.	Inspect the foreign objects on sensor or bill path and clean.
3+2		Hook sensor error.	Inspect the foreign objects on security hook and clean.
3+4		Fish sensor error	Inspect the foreign objects on sensor or bill path and clean.
4		A stringing attempt has detected.	Inspect the foreign objects on sensor or bill path and clean.
5		Bill box has been removed. (L83 with bill box only)	Replace the bill box.
6		Stacker error or stacker full. (for modules with bill box only).	Empty the bill box.
7		Motor error.	Inspect the foreign objects on bill path and clean.



**If the error can not be solved after corrective actions or happen again, please contact ICT for technical support.**

## ccTalk Information

- Manufacturer ID: ICT
- Equipment Category ID: Bill Acceptor
- Product Code: L83/ L77F/ L70F/ L70T/ L77T
- Serial Number: According to last 8 digits of production serial number.

**Default: 12345678**

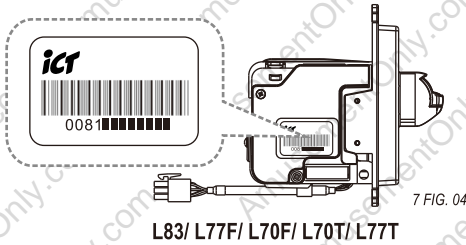

- Software Revision: According to the software revision number.

**Ex. L8DX06HAH10N241EU720**

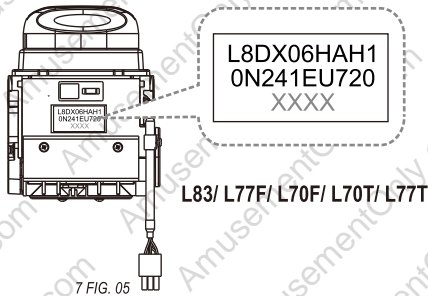

- Encryption Mode Password: Default as 123456  
(command changeable).



**Please contact ICT for more information.**



Taiwan

**International Currency Technologies Corporation**

No.28, Ln. 15, Sec. 6, Minquan E. Rd., Neihu Dist., Taipei City 114, Taiwan

[sales@ictgroup.com.tw](mailto:sales@ictgroup.com.tw) (For Sales)

[fae@ictgroup.com.tw](mailto:fae@ictgroup.com.tw) (For Customer Service)

Website: [www.ictgroup.com.tw](http://www.ictgroup.com.tw)

