



L70T-P5 / L77T-P5

Bill Acceptor



Installation Guide

International Currency Technologies Corp.

Use of Materials Limitations

International Currency Technologies Corporation (ICT) all rights reserved.

All materials contained are the copyrighted property of ICT.

All trademarks, service marks, and trade names are proprietary to ICT.

ICT reserves the right at all times to disclose or to modify any information as ICT deems necessary to satisfy any applicable law, regulation, legal process or governmental request, or to edit, refuse to post or to remove any information or materials, in whole or in part, in ICT's sole discretion.

Contents

1. Introduction	
1-1. Overview	2
1-2. Features	2
2. Specifications	3
3. Packing List	5
4. Dimension	6
5. Installation	
5-1. Harness Application	15
5-1-1. I/O Circuit	39
5-2. DIP Switch Setting	45
5-3. Software Download and Upgrade	45
6. Maintenance	46
7. Troubleshooting	47

Appendix_ccTalk Information

1. Introduction

1-1. Overview

The L Series bill acceptor combines improved bill-sensing technology with lightweight and durable plastic construction. It also features fast software updating, automatic self-adjusting sensor system, and easy maintenance to increase acceptance rates and reduce bill jammed.

1-2. Features

- Auto-calibration.
- Easy maintenance.
- Fast program update.
- Selective interfaces.
- Anti-string technology.
- Speedy bill transaction.
- Multicolor illumination bezel design.
- Multinational currencies acceptable.
- Fixed width/ multi-width bill acceptable.
- Lightweight and durable plastic construction.
- New generation design of verification system.

2. Specifications

General

Acceptance Rate 96% or greater

**Note: The Incomplete bills such as extremely dirty, wet, broken, or wrinkled ones are excluded!*

Bill Insertion Four way acceptable

Transaction Time Approx. 3 seconds to stack

Interface

L70#:

Pulse, RS232, RS232 A0, ccNet(compatible), MDB, ccTalk.

L70:

Pulse, RS232, RS232 A0, Parallel A1

L70F, L77F:

Pulse, RS232, RS232 A0, ccNet(compatible), MDB, ccTalk, Pulse(Out of service).

L83:

Pulse, RS232, RS232 A0, ccNet(compatible), MDB, ccTalk, RS232 A1, Parallel, Pulse(Out of service), Parallel A4.

L83#:

Pulse, RS232, RS232 A0, ccNet(compatible), MDB, ccTalk, RS232 A1, Pulse(Out of service)

L70T, L77T:

Pulse, RS232, RS232 A0, ccNet(compatible), MDB, ccTalk, Pulse(Out of service) , V2.2.

**Note: For ccTalk information, please refer to Appendix.*

Electrical

Power Source

L70#, L70F, L77F, L83#, L70T, L77T:

12V DC(10~16V DC)

Others: 12V DC(10.8~13.2V DC)

Power Consumption

Standby : 0.3A, 3.6W

Operation: 1.2A, 14.4W

Maximum: 2A, 24W

Operation Environment

Operation Temperature:

L70, L83: 0°C~50°C

L70F, L77F, L70T, L77T: 0°C~60°C

L70#, L83#: 0°C~65°C

Storage Temperature: -20°C~70°C

Humidity: 30%~85%RH(no condensation)

Mechanical

Outline Dimension

L70#-P2/P5, L70F-P2/P5 :

N Type Bezel Refer to page. 6

O Type Bezel Refer to page. 7

L77F-P2/P5: I Bezel Refer to page. 8

L83-P3/P6, L83#-P3/P6:

E Type Bezel Refer to page. 9

F Type Bezel Refer to page.10

Y Type Bezel Refer to page.11

L70T-P5, L77T-P5:

Without metal bracket Refer to page.12

With metal bracket Refer to page.13

Bill Box Capacity

L70#-P2, L70F-P2: Approx.200 bills

L70#-P5, L70F-P5: Approx.500 bills

L77F-P2: Approx.150 bills

L77F-P5: Approx.500 bills

L83-P3, L83#-P3: Approx.300 bills

L83-P6, L83#-P6: Approx.600 bills

L70T-P5, L77T-P5: Approx.500 bills

Weight

L70#, L70F: Approx.0.52kg
L70#-P2, L70F-P2: Approx.1.25kg
L70#-P5, L70F-P5: Approx.1.4kg
L77F: Approx.0.44kg
L77F-P2: Approx.1.35kg
L77F-P5: Approx.1.42kg
L83, L83#: Approx.0.8kg
L83-P3, L83#-P3: Approx.1.46kg
L83-P6, L83#-P6: Approx.1.65kg
L70T-P5, L77T-P5: (Without metal bracket) Approx.1.42kg
 (With metal bracket) Approx.7kg

Bill Accepted Width

L70#-P2/P5, L70F-P2/P5:
 (67mm) 59mm~67mm
 (71mm) 59mm~71mm
L77F-P2/P5: 72mm~77mm
L83-P3/P6, L83#-P3/P6:
 61mm~83mm
 61mm~79mm(Y Type Bezel)
L70T-P5: 65mm~70mm
L77T-P5: 72mm~77mm

Installation

Indoor

3. Packing List

Main

Bill Acceptor

Accessory

Harness: Refer to **5-1**
 Bezel Sticker
 Screw Pack
 L Series Installation Guide
 L Series DIP Switch Setting Guide

4. Dimension

L70 N Type Bezel: A Bezel(67mm) and B Bezel(71mm)

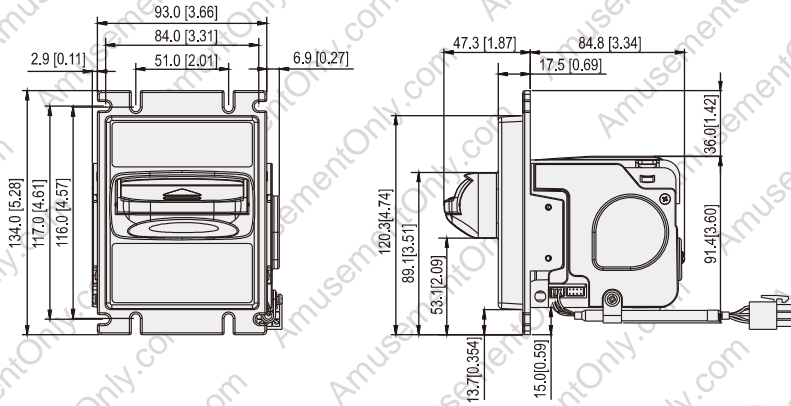

4 FIG.01

L70-P2/P5 N Type Bezel: A Bezel(67mm) and B Bezel(71mm)

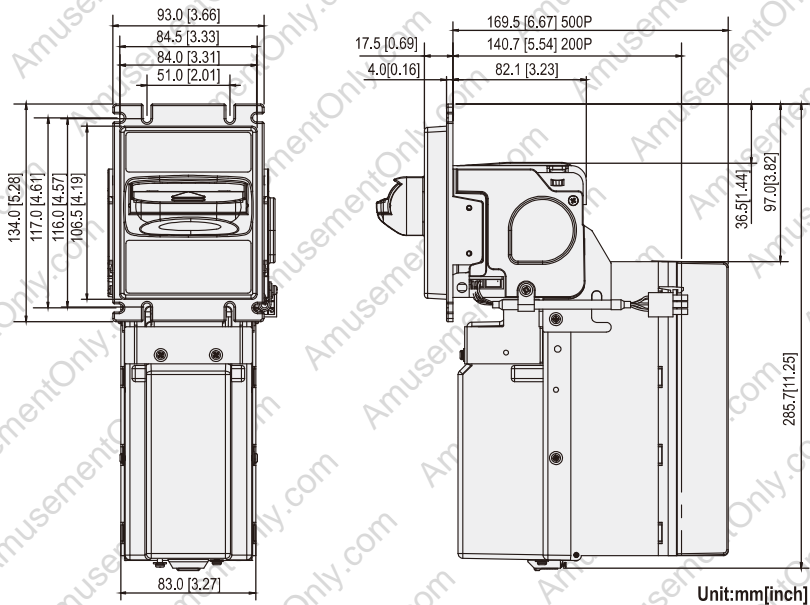

Unit:mm[inch]

4 FIG.02

L70 O Type Bezel (71mm)

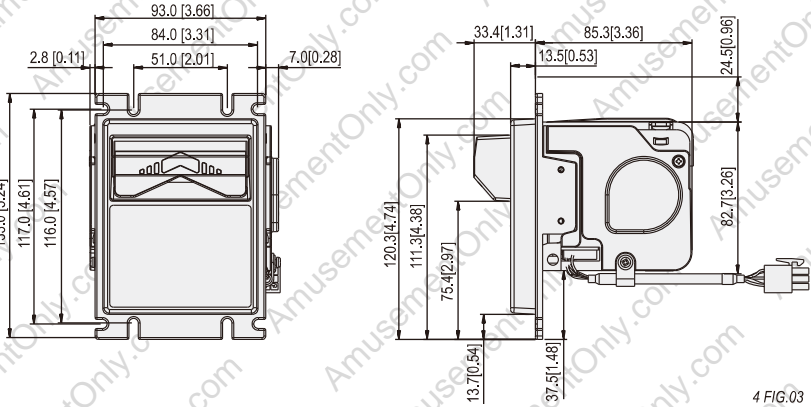

4 FIG.03

L70-P2/P5 O Type Bezel (71mm)

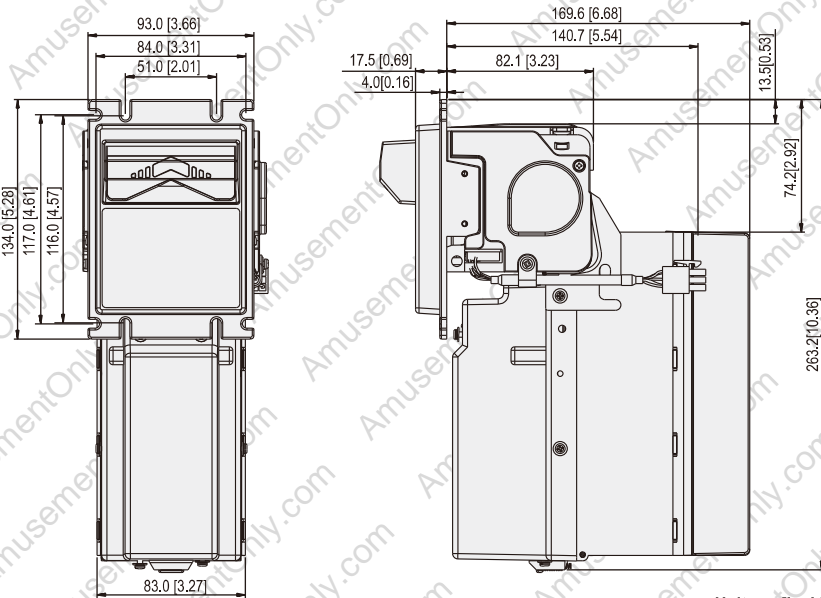

Unit:mm[inch]

4 FIG.04

L77F | Bezel (78mm)

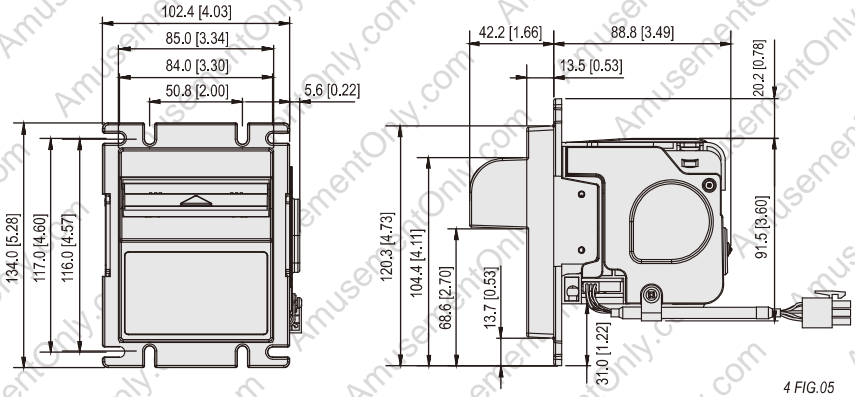

L77F-P2/P5 | Bezel (78mm)

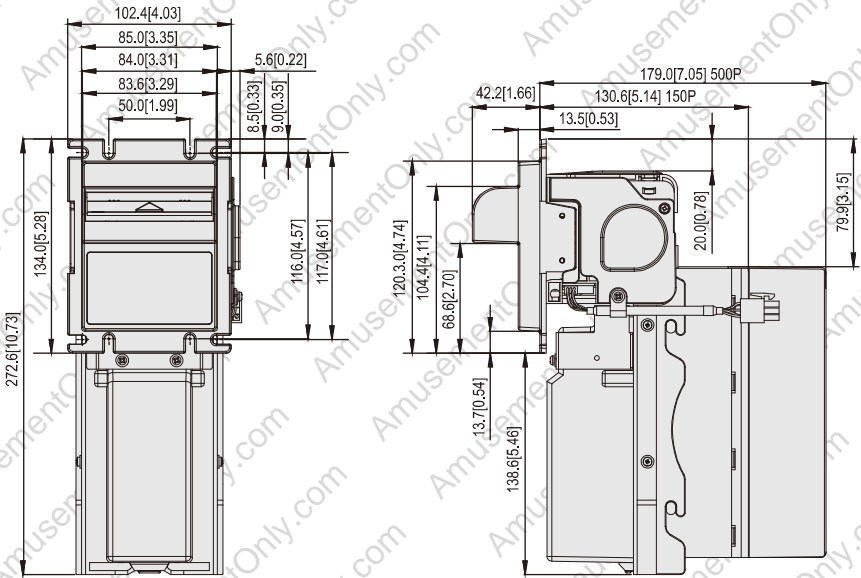

Unit:mm[inch]

4 FIG.06

L83 E Type Bezel (83mm)

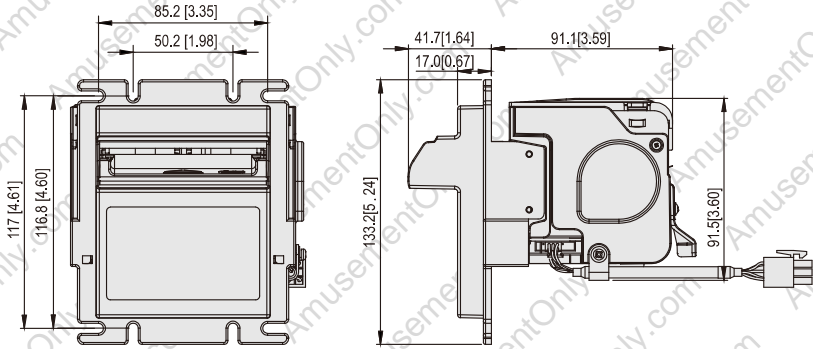

4 FIG.07

L83-P3/P6 Down Stacker E Type Bezel (83mm)

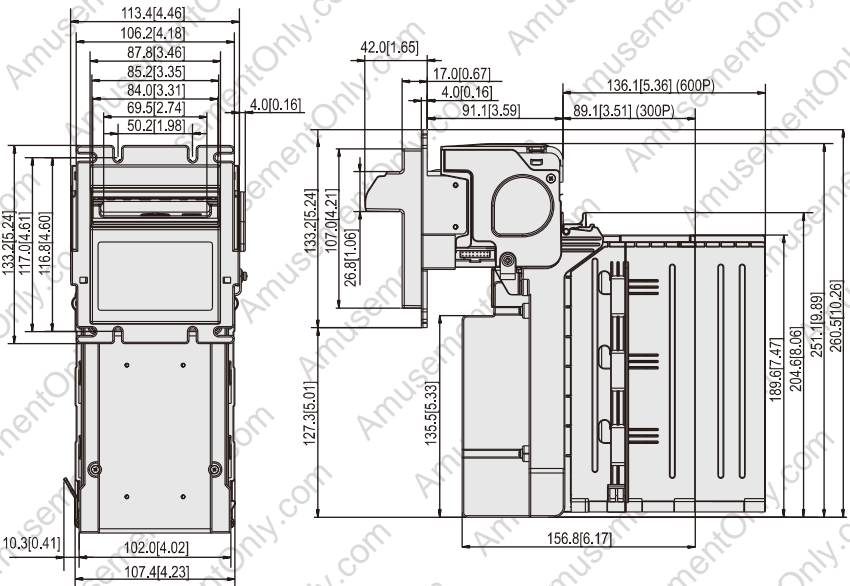

Unit:mm[inch]

4 FIG.08

L83-P3/P6 Down Stacker F Type Bezel (83mm)

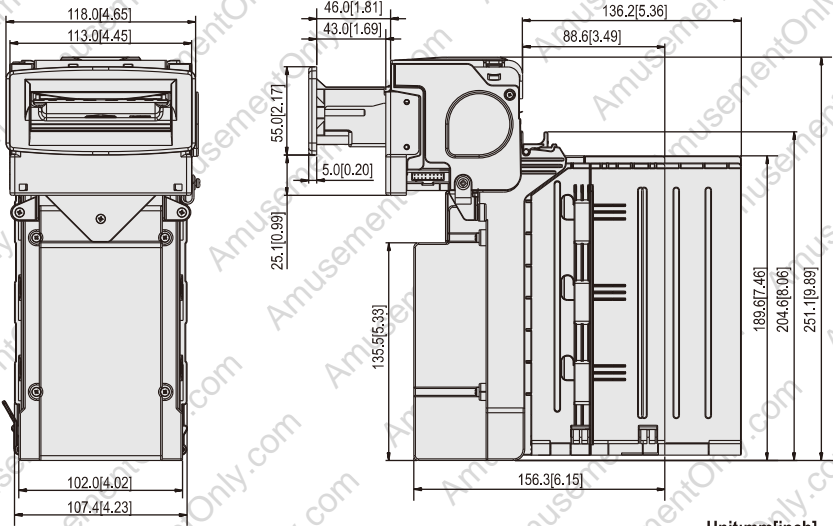

Unit:mm[inch]

4 FIG.09

L83 Y Type Bezel (79mm)

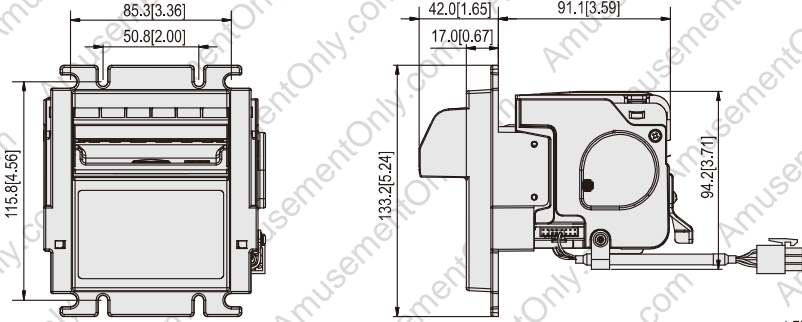

4 FIG.10

L83-P3/P6 Down Stacker Y Type Bezel (79mm)

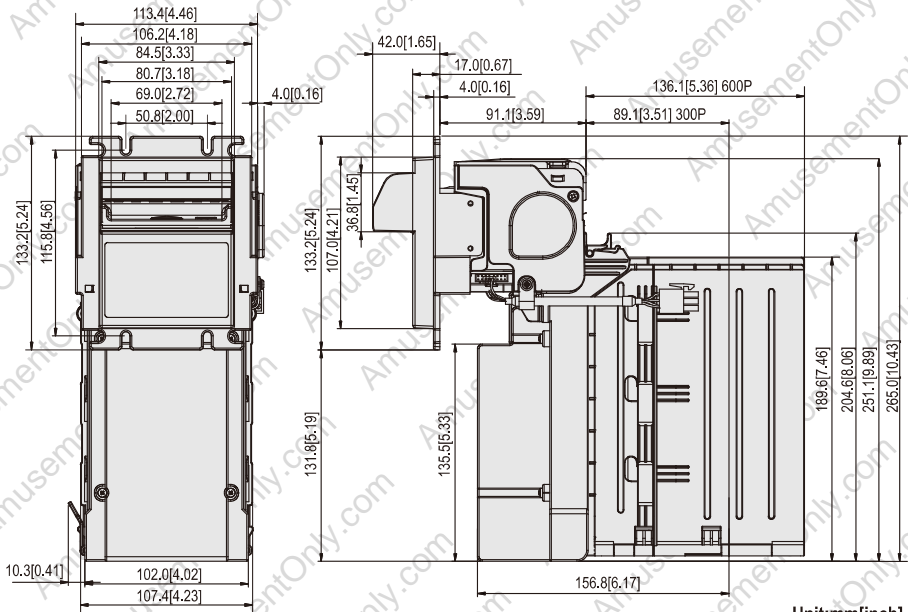

Unit:mm[inch]

4 FIG.11

L70T-P5, L77T-P5 <Without metal bracket>

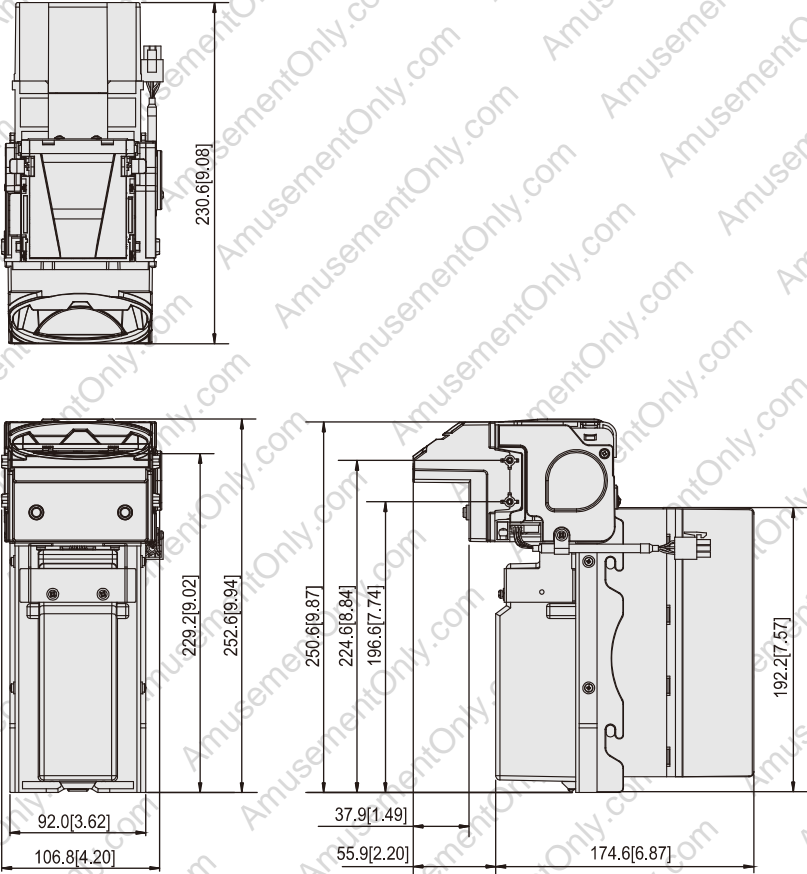

Unit:mm[inch]

4 FIG.12

L70T-P5, L77T-P5 <With metal bracket>

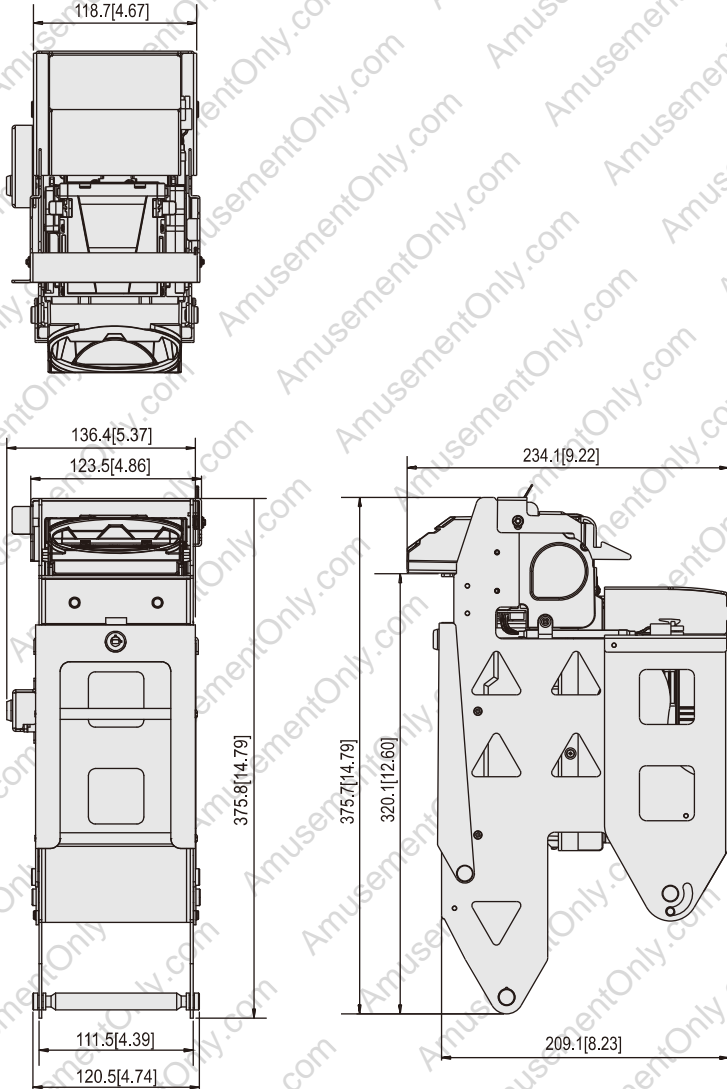

Unit:mm[inch]

4 FIG.13



To install the bill acceptor on your VMC, please be aware of the dimension as below:

[L] : Longer than the maximum length of accepted bills.

[L1] : Bill box capacity depth.

* [L/2] has to be longer than 70mm to open upper base.

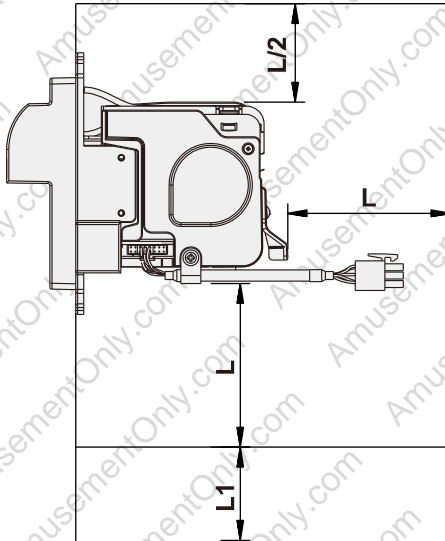

4 FIG.14

5. Installation

5-1. Harness Application

5-1 TABLE 01

Model	Interface	Used Voltage	Usage	Harnesses	Page
L70	Pulse	12V DC	Power & *Data Comm. ★3	WEL-RL702	20
			Extension Wire	CU-R961-1	19
	ICT(RS232)	12V DC	Power & *Data Comm.	WEL-RL703 ★1	21
	Parallel A1	12V DC	Power & *Data Comm.	WEL-RL701	20
			Extension Wire	WEL-R061	23
	RS232 A0	12V DC	Power & *Data Comm.	WEL-RL705-1	22
			Extension Wire	WEL-RID04	23
	ccTalk	12V DC	Power & *Data Comm. (BA↔Plug-in Board)	5RBA-RAB248MX	
L70# L70F L77F	Pulse	12V DC	Power & *Data Comm.	WEL-R7U02	24
			Extension Wire	CU-R961-1	19
	ICT (RS232)	12V DC	Power & *Data Comm.	WEL-R7U02	24
			Extension Wire	CU-R961-1	19
			*Data Comm.	WEL-R7U06-2 ★2 or 2-BA-R7U06	25
	ccNet compatible	12V DC	Power & *Data Comm.	WEL-R7U02	24
			Extension Wire	CU-R961-1	19
			*Data Comm.	WEL-R7U06-2 ★2 or 2-BA-R7U06	25
	RS232 A0	12V DC	Power & *Data Comm.	WEL-R7U02	24
			Extension Wire	CU-R961-1	19
			*Data Comm.	WEL-R7U06-2 ★2 or 2-BA-R7U06	25
	MDB	★4 34V DC	Power & *Data Comm. (BA↔Plug-in Board) ★5	WEL-RBG01	26
			Power & *Data Comm.(35cm) (Plug-in Board↔VMC)	WEL-RBG08	27
			Power & *Data Comm.(200cm) (Plug-in Board↔VMC)	WEL-RBG07	26

★1. Maintenance use only.

★2. WEL-R7U06-2 : TTL Level to ±12VDC Level for PC.

★3. Data Comm. : Data Communication.

★4. MDB 34VDC : VMC Provides +34VDC to MDB Plug-in Board to convert into +12VDC, and provides +12VDC to L series bill acceptors.

★5. MDB Box : 5RBG-AA313NA0 For L70#, L70F, L77F, L70T, L77T, 5RBG-AA313NAA For L83, L83#.

Model	Interface	Used Voltage	Usage	Harnesses	Page
L70#	ccTalk	12V DC	Power & *Data Comm. ★3 (BA↔Plug-in Board)	5RBA-RAA248MX	
	ccTalk	12V DC	Power	WEL-R7U02	24
			*Data Comm.	3-BA-RL70#RS232-B	27
	Pulse	110V AC	Power & *Data Comm. (BA↔Plug-in Board)	5RBA-RAA315-L	29 30
L70F L77F	Pulse (Out of service)	12V DC	Power & *Data Comm.	WEL-RL826	36
			Extension Wire	CU-R961-1	19
	ccTalk	12V DC	Power & *Data Comm.	WEL-RL77F01	28
L83	Pulse	12V DC	Power & *Data Comm.	WEL-RL802	31
			Extension Wire	CU-R961-1	19
	ccTalk	12V DC	Power & *Data Comm.	WEL-RL803	32
				IDC-RA10400	38
				CNT-R7025	38
				WEL-RL824	34
	RS232 A1	12V DC	Power & *Data Comm.	WEL-RL805	33
	ICT (RS232)	12V DC	Power	WEL-RL802	31
			Extension Wire	CU-R961-1	19
			*Data Comm.	WEL-R7U06-2 ★2 or 2-BA-R7U06	25
	ccNet compatible	12V DC	Power	WEL-RL802	31
			Extension Wire	CU-R961-1	19
			*Data Comm.	WEL-R7U06-2 ★2 or 2-BA-R7U06	25
	MDB	34V DC ★4	Power & *Data Comm. ★5 (BA↔Plug-in Board)	WEL-RL812	34
			Power & *Data Comm.(35cm) (Plug-in Board↔VMC)	WEL-RBG08	27
Power & *Data Comm.(200cm) (Plug-in Board↔VMC)			WEL-RBG07	26	
RS232 A0	12V DC	Power	WEL-RL802	31	
		Extension Wire	CU-R961-1	19	
		*Data Comm.	WEL-R7U06-2 ★2 or 2-BA-R7U06	25	

★2. WEL-R7U06-2 : TTL Level to ±12VDC Level for PC.

★3. Data Comm. : Data Communication.

★4. MDB 34VDC : VMC Provides +34VDC to MDB Plug-in Board to convert into +12VDC, and provides +12VDC to L series bill acceptors.

★5. MDB Box : 5RBG-AA313NA0 For L70#, L70F, L77F, L70T, L77T, 5RBG-AA313NAA For L83, L83#.

5-1 TABLE 03

Model	Interface	Used Voltage	Usage	Harnesses	Page
L83	Parallel	12V DC	Power & *Data Comm. ★3	WEL-RL804	32
	Parallel A4		Power & *Data Comm.	WEL-RL806	33
	Pulse(Out of service)		Power & *Data Comm.	WEL-RL825	35
			Extension Wire	CU-R961-1	19
L83#	Pulse	12V DC	Power & *Data Comm.	WEL-RL802	31
			Extension Wire	CU-R961-1	19
	ccTalk	12V DC	Power & *Data Comm.	WEL-RL803	32
				IDC-RA10400	38
				CNT-R7025	38
				WEL-RL824	34
	RS232 A1	12V DC	Power & *Data Comm	WEL-RL805	33
	ICT (RS232)	12V DC	Power	WEL-RL802	31
			Extension Wire	CU-R961-1	19
			*Data Comm.	WEL-R7U06-2 ★2 or 2-BA-R7U06	25
	ccNet compatible	12V DC	Power	WEL-RL802	31
			Extension Wire	CU-R961-1	19
			*Data Comm.	WEL-R7U06-2 ★2 or 2-BA-R7U06	25
	MDB	34V DC ★4	Power & *Data Comm. ★5 (BA↔Plug-in Board)	WEL-RL812	34
			Power & *Data Comm.(35cm) (Plug-in Board↔VMC)	WEL-RBG08	27
			Power & *Data Comm.(200cm) (Plug-in Board↔VMC)	WEL-RBG07	26
	RS232 A0	12V DC	Power	WEL-RL802	31
			Extension Wire	CU-R961-1	19
			*Data Comm.	WEL-R7U06-2 ★2 or 2-BA-R7U06	25
	Pulse(Out of service)	12V DC	Power & *Data Comm.	WEL-RL825	35
Extension Wire			CU-R961-1	19	

★2. WEL-R7U06-2 : TTL Level to ±12VDC Level for PC.

★3. Data Comm. : Data Communication.

★4. MDB 34VDC : VMC Provides +34VDC to MDB Plug-in Board to convert into +12VDC, and provides +12VDC to L series bill acceptors.

★5. MDB Box : 5RBG-AA313NA0 For L70#, L70F, L77F, L70T, L77T, 5RBG-AA313NAA For L83, L83#.

Model	Interface	Used Voltage	Usage	Harnesses	Page
L70T L77T	Pulse	12V DC	Power & *Data Comm. ★3	WEL-R7U02	24
			Extension Wire	CU-R961-1	19
	ICT (RS232)	12V DC	Power & *Data Comm.	WEL-R7U02	24
			Extension Wire	CU-R961-1	19
			*Data Comm.	WEL-R7U06-2 ★2 or 2-BA-R7U06	25
	ccNet compatible	12V DC	Power & *Data Comm.	WEL-R7U02	24
			Extension Wire	CU-R961-1	19
			*Data Comm.	WEL-R7U06-2 ★2 or 2-BA-R7U06	25
	MDB	★4 34V DC	Power & *Data Comm. (BA↔Plug-in Board) ★5	WEL-RBG01	26
			Power & *Data Comm.(35cm) (Plug-in Board↔VMC)	WEL-RBG08	27
			Power & *Data Comm.(200cm) (Plug-in Board↔VMC)	WEL-RBG07	26
	Pulse (Out of service)	12V DC	Power & *Data Comm.	WEL-RL826	36
			Extension Wire	CU-R961-1	19
	RS232 A0	24V DC	Power & *Data Comm.	3BA-RAA318-NX-0X	37
	V2.2				37
	ccTalk	12V DC	Power & *Data Comm.	WEL-RL77F01	28

★2. WEL-R7U06-2 : TTL Level to ±12VDC Level for PC.

★3. Data Comm. : Data Communication.

★4. MDB 34VDC : VMC Provides +34VDC to MDB Plug-in Board to convert into +12VDC, and provides +12VDC to L series bill acceptors.

★5. MDB Box : 5RBG-AA313NA0 For L70#, L70F, L77F, L70T, L77T, 5RBG-AA313NAA For L83, L83#.

5-1 FIG. 01

Interface	Used Voltage	Usage
Pulse	12V DC	Extension Wire for WEL-RL702
Pulse	12V DC	
ICT(RS232)	12V DC	Extension Wire for WEL-R7U02
ccNet compatible	12V DC	
RS232 A0	12V DC	
Pulse	12V DC	Extension Wire for WEL-RL802
ICT(RS232)	12V DC	
ccNet compatible	12V DC	
Pulse(Out of service)	12V DC	Extension Wire for WEL-RL825
Pulse(Out of service)	12V DC	Extension Wire for WEL-RL826

CU-R961-1



AMP 172332-1



AMP 172332-1
BACK VIEW

- PIN 1- YELLOW.....INHIBIT+
- PIN 2- GREEN.....INHIBIT-
- PIN 5- RED.....+12VDC(POWER-IN)
- PIN 7- BLUE.....CRECIT-RELAY-NO
- PIN 8- PURPLE.....CREDIT-RELAY-COM
- PIN 9- ORANGE.....GND(POWER-IN)

5-1 FIG.02

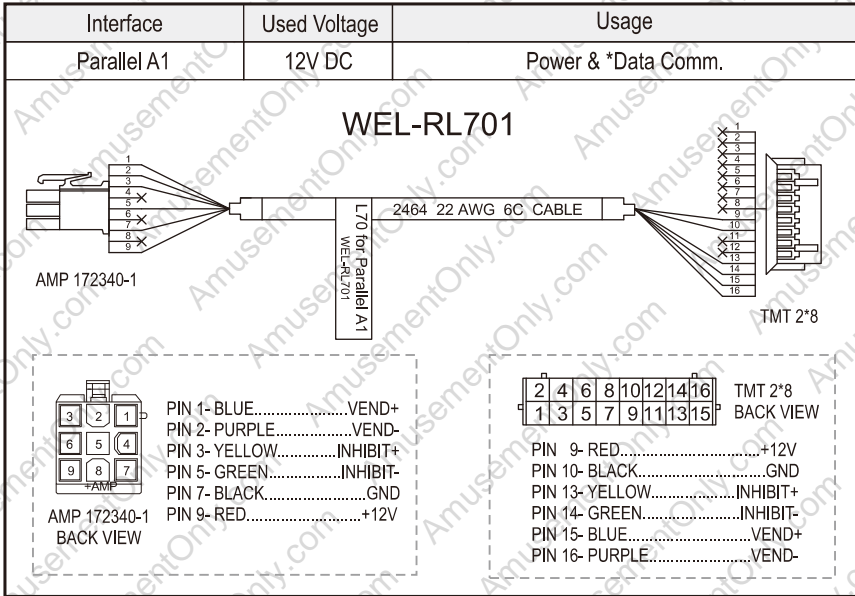

5-1 FIG.03

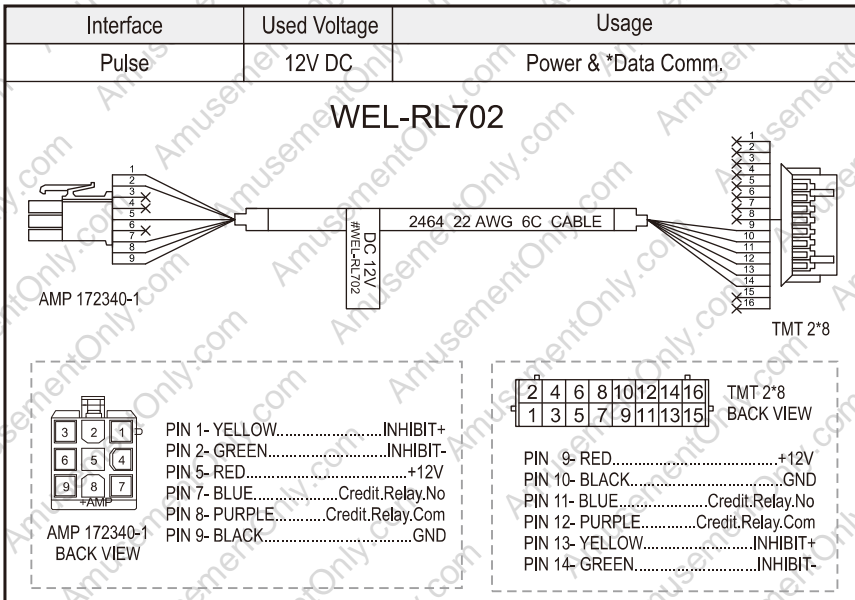

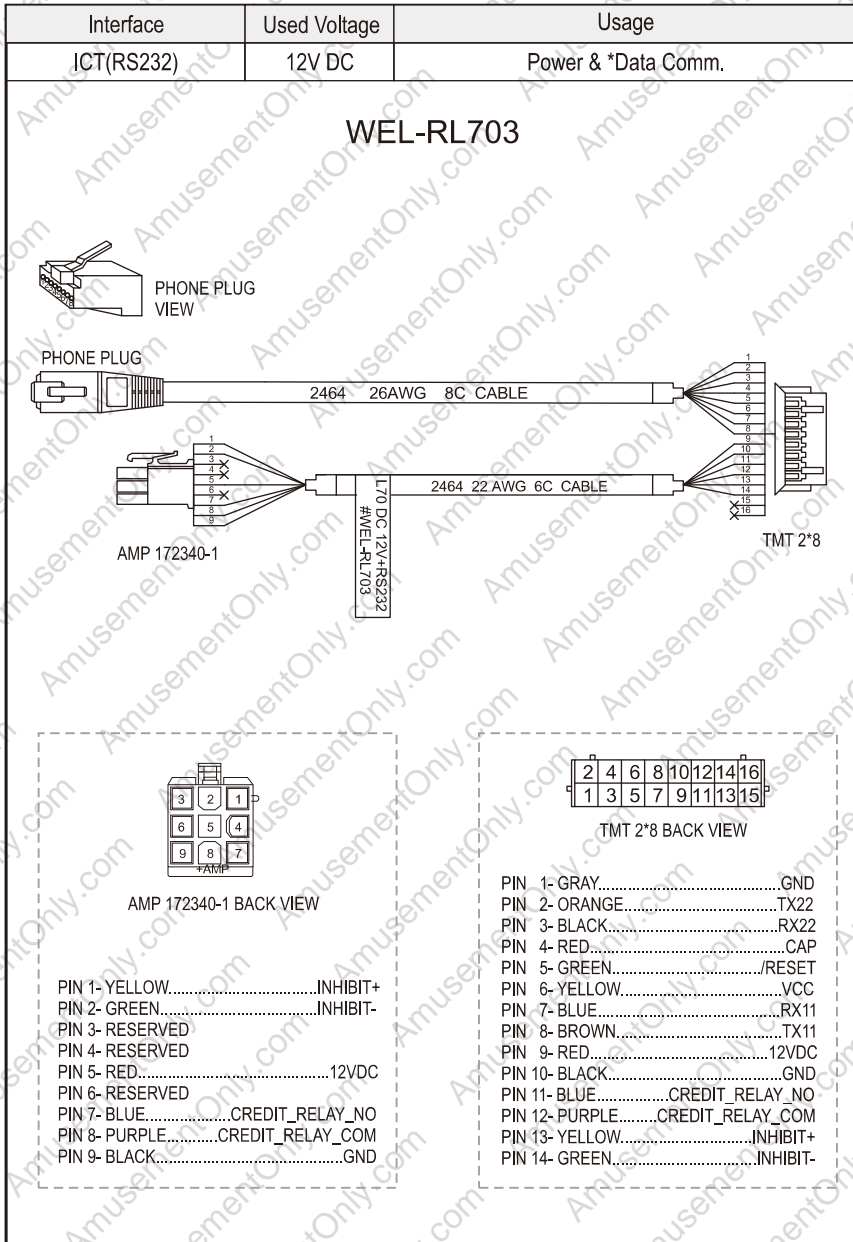

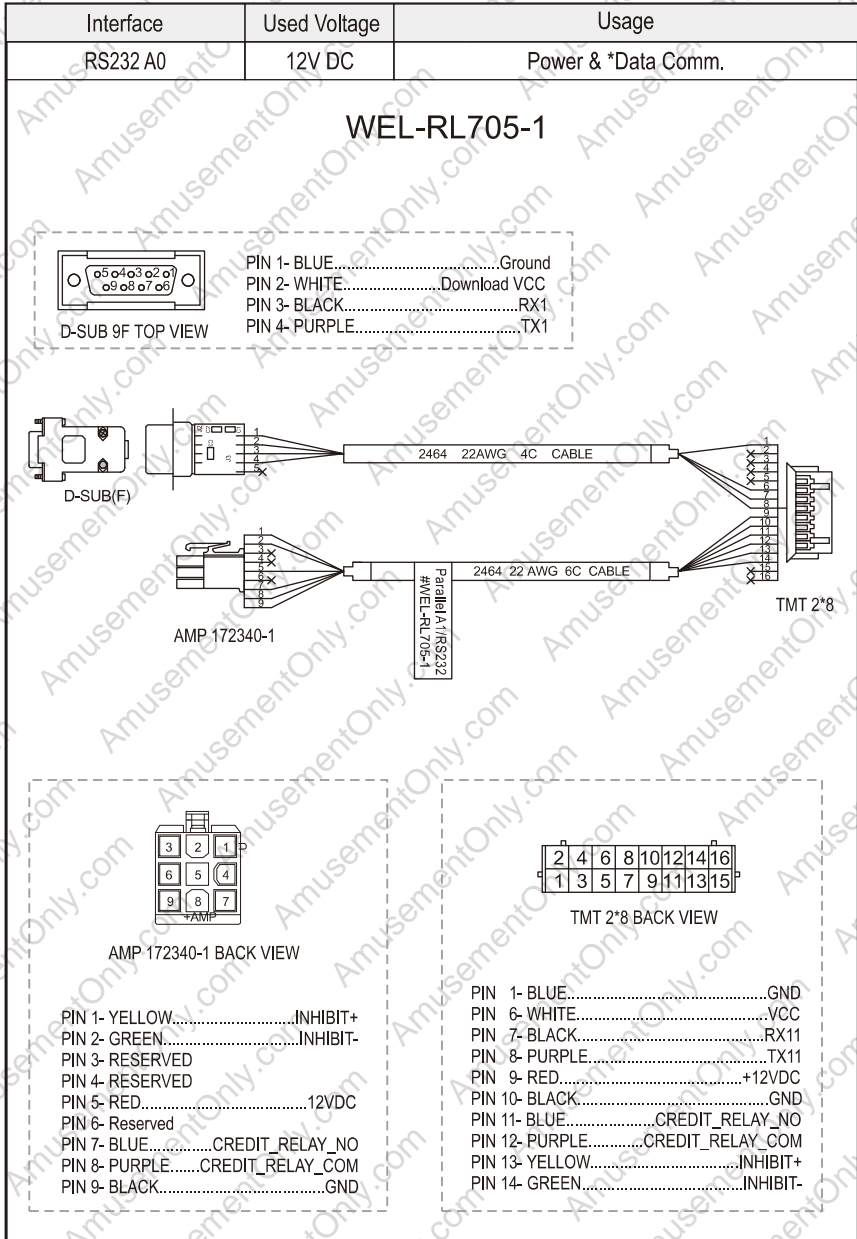

5-1 FIG.06

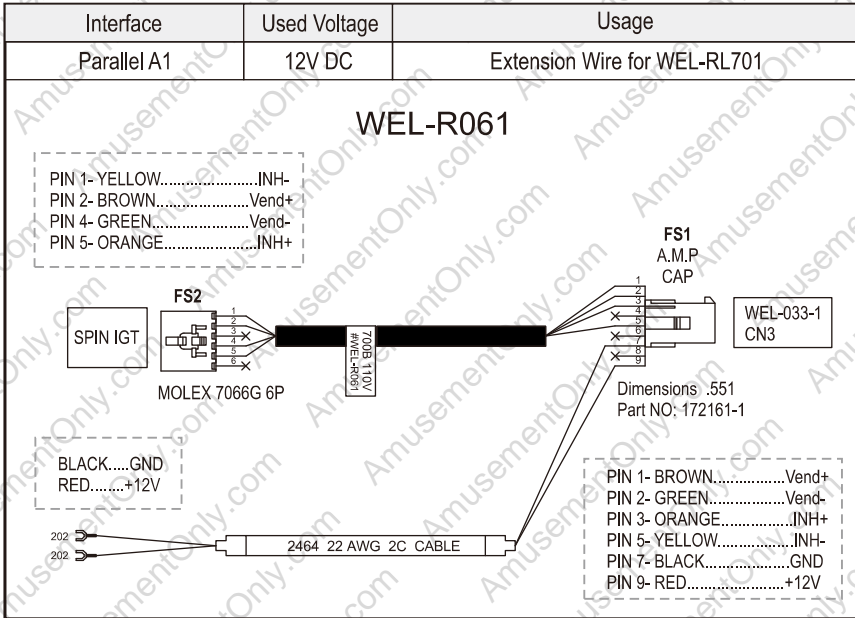

5-1 FIG.07

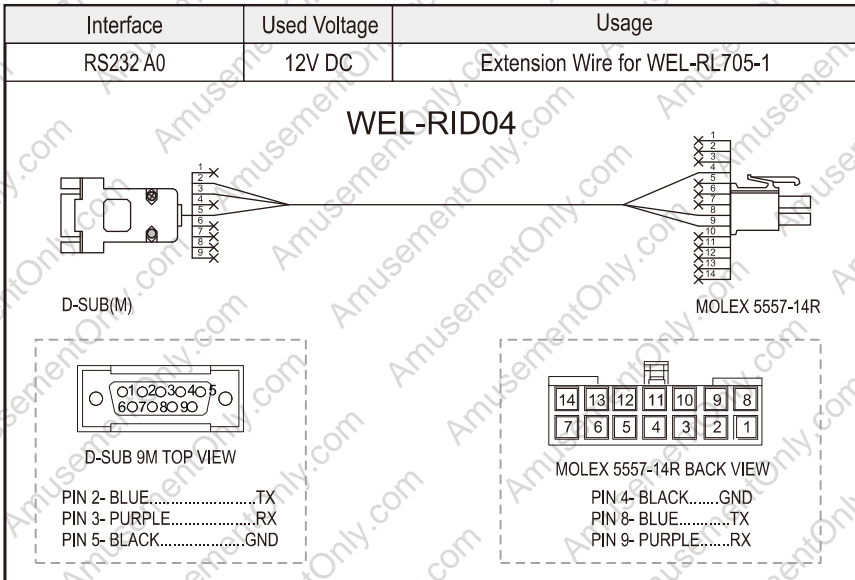

Interface	Used Voltage	Usage
Pulse	12V DC	Power & *Data Comm.
ICT(RS232)	12V DC	Power
ccNet compatible	12V DC	Power
RS232 A0	12V DC	Power
ccTalk	12V DC	Power

WEL-R7U02

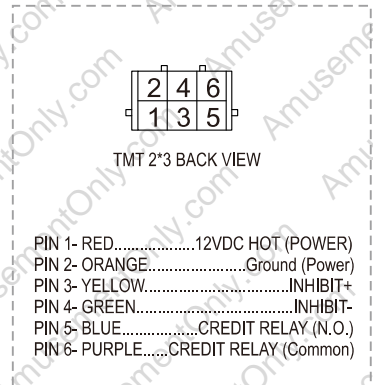
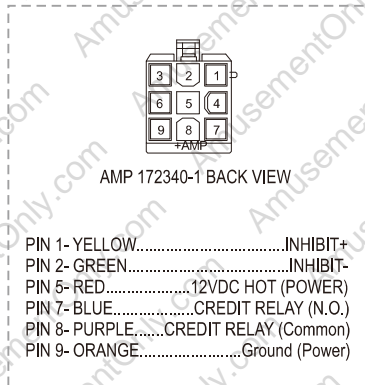
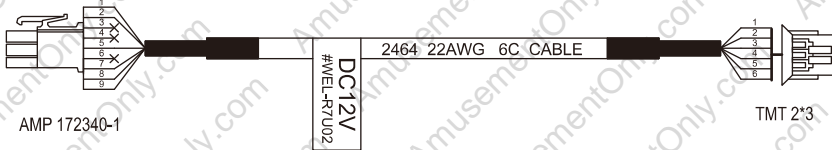

5-1 FIG.09

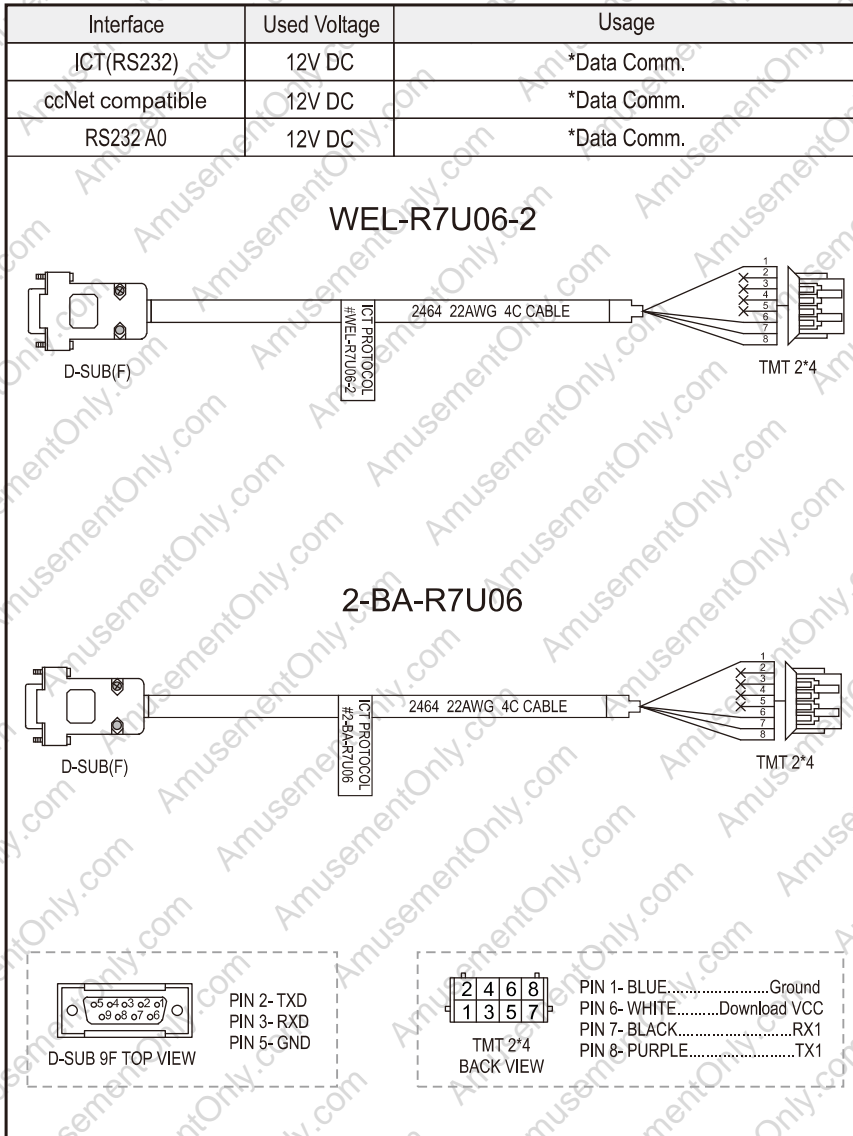

5-1 FIG. 10

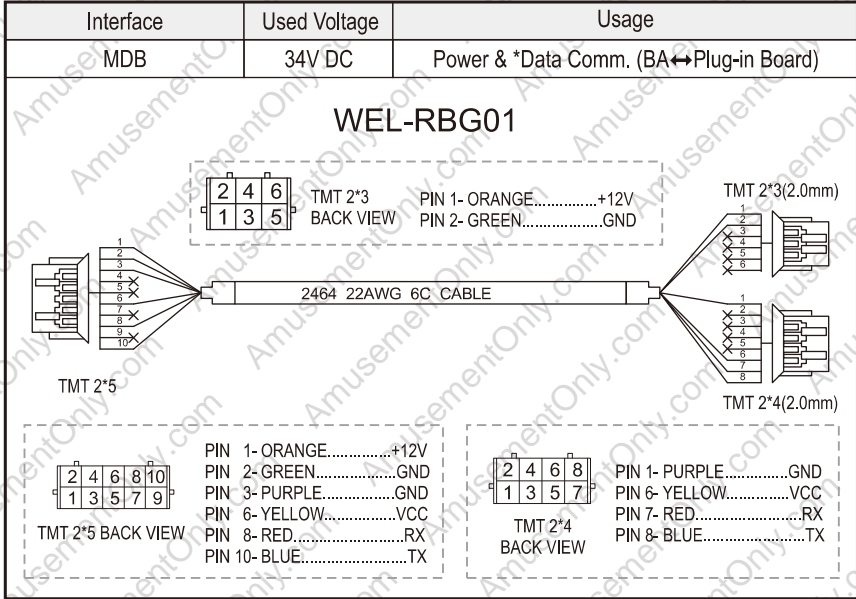

5-1 FIG. 11

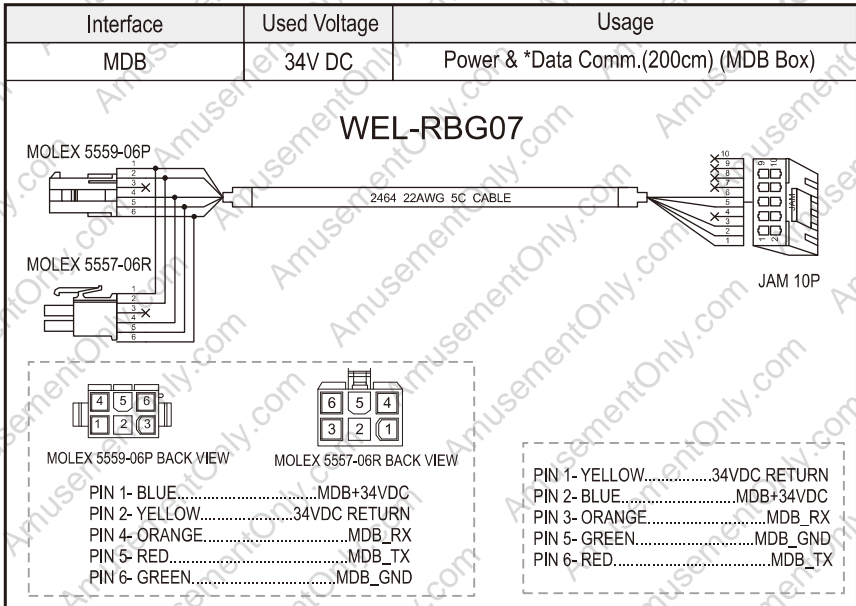

5-1 FIG.12

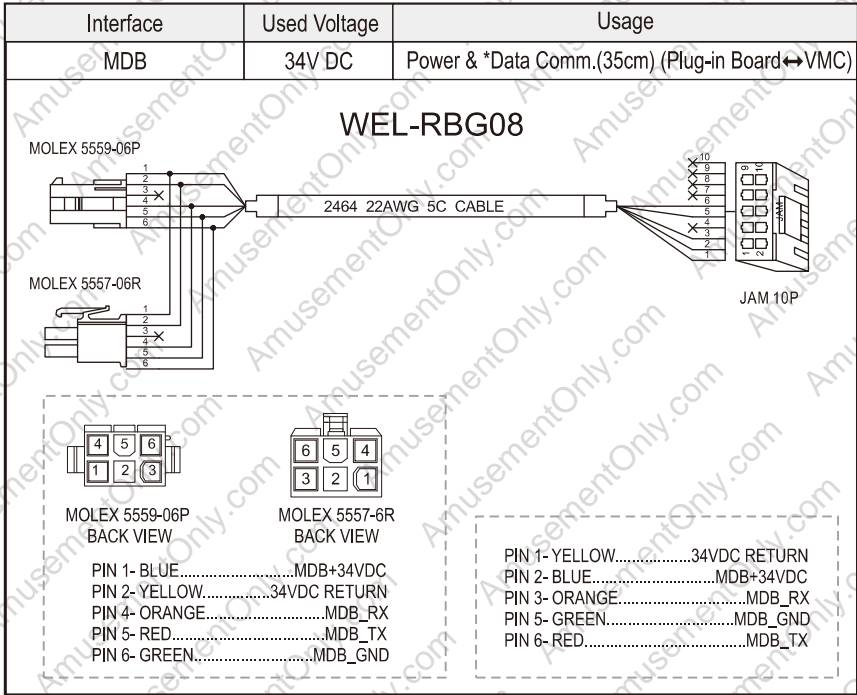

5-1 FIG.13

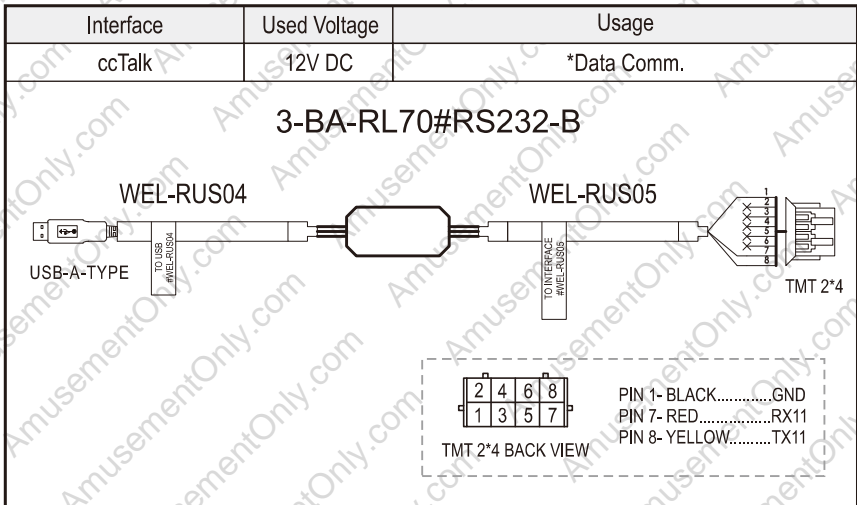

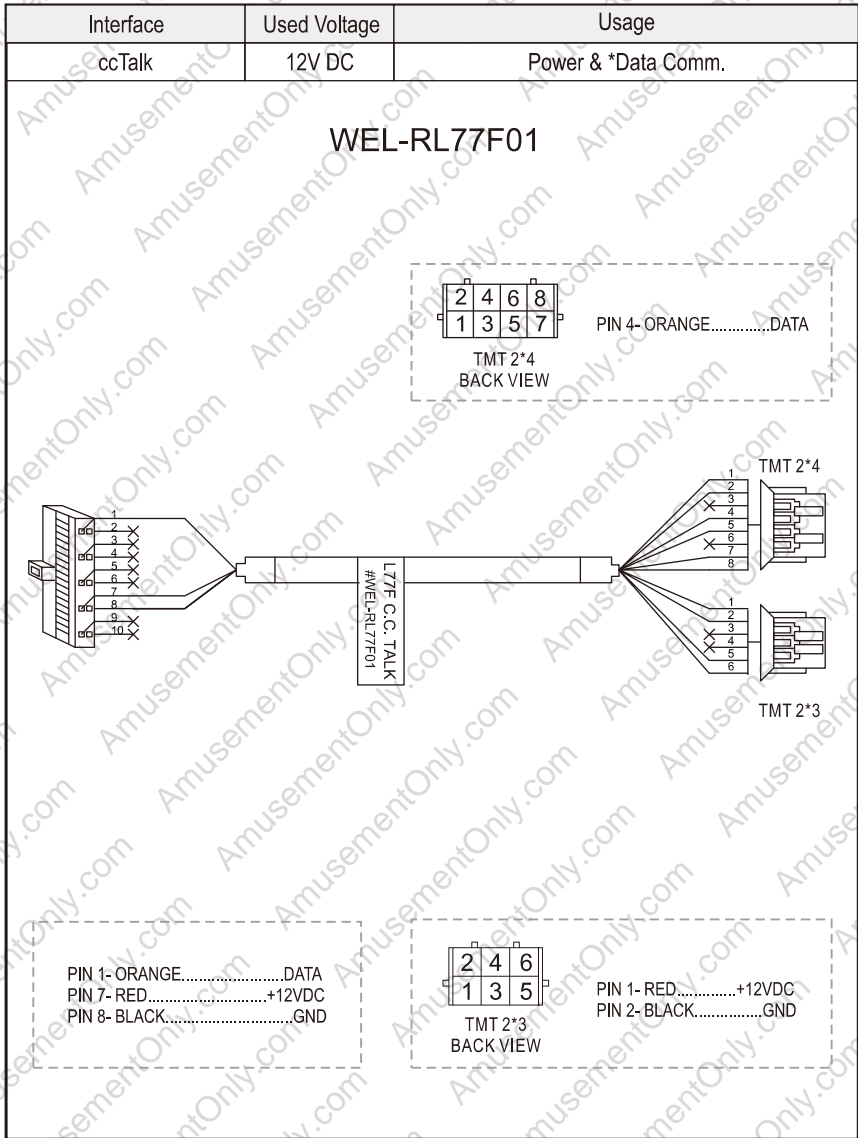

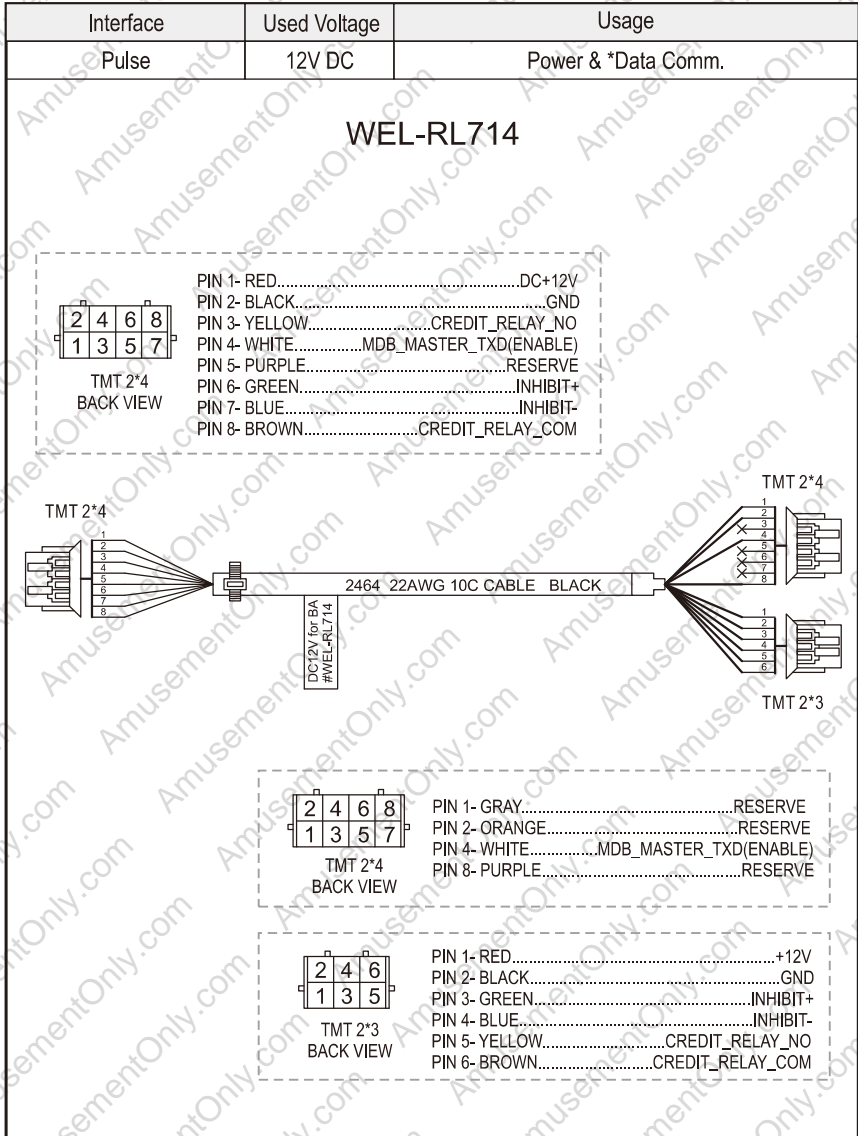

Interface	Used Voltage	Usage
Pulse	12V DC	Power & *Data Comm.
ccNet compatible	12V DC	Power
ICT(RS232)	12V DC	Power

WEL-RL802

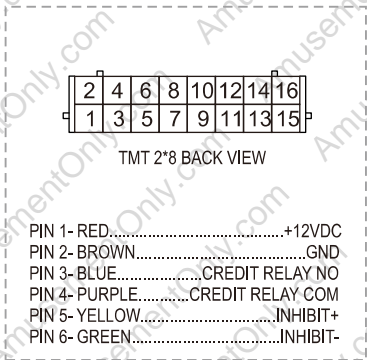
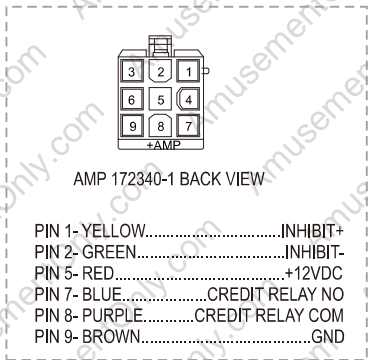
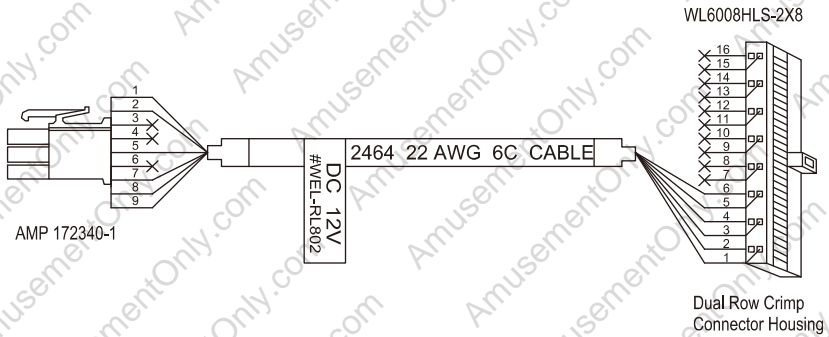

5-1 FIG. 18

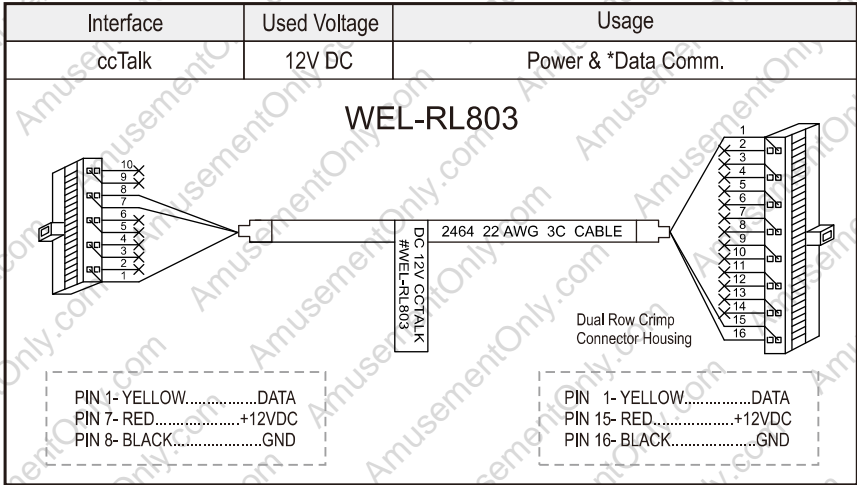

5-1 FIG. 19

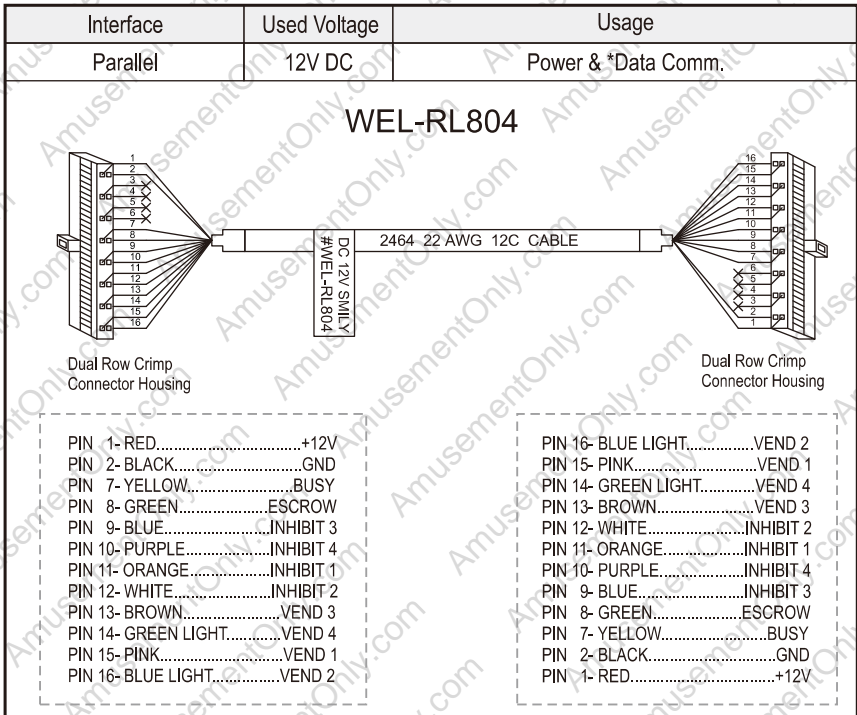

5-1 FIG.20

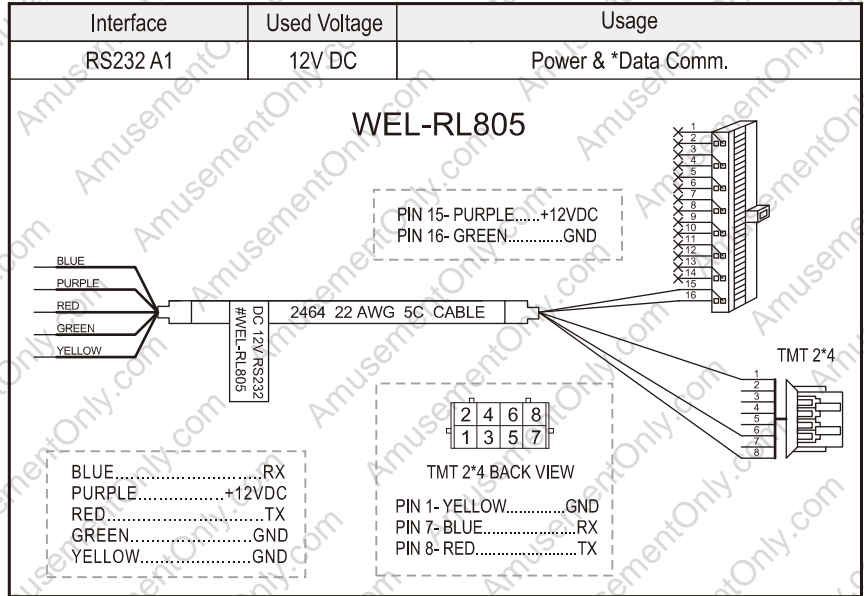

5-1 FIG.21

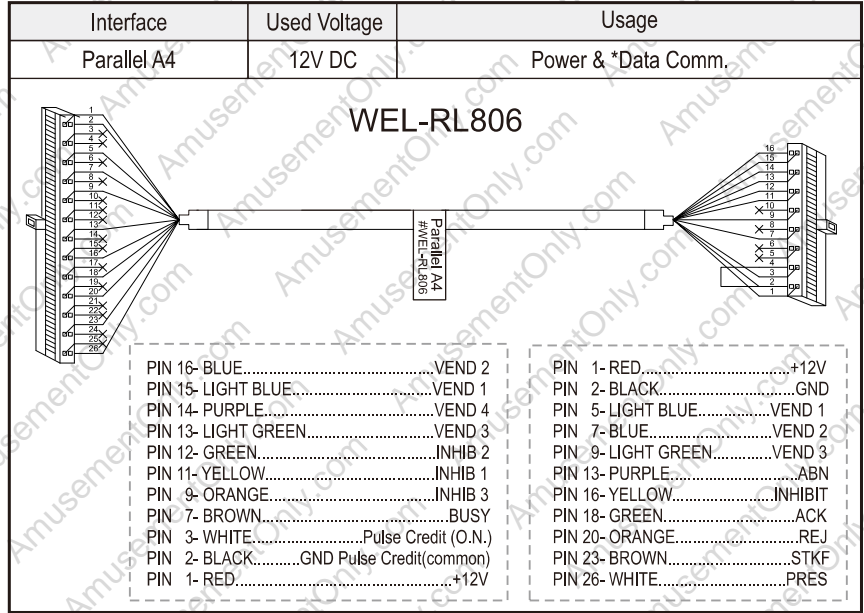

5-1 FIG.22

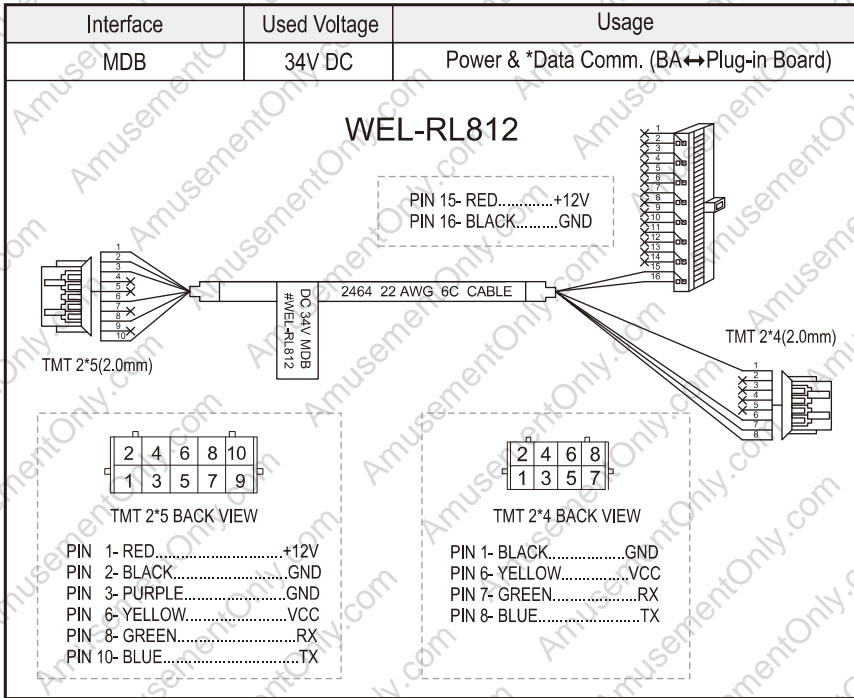

5-1 FIG.23

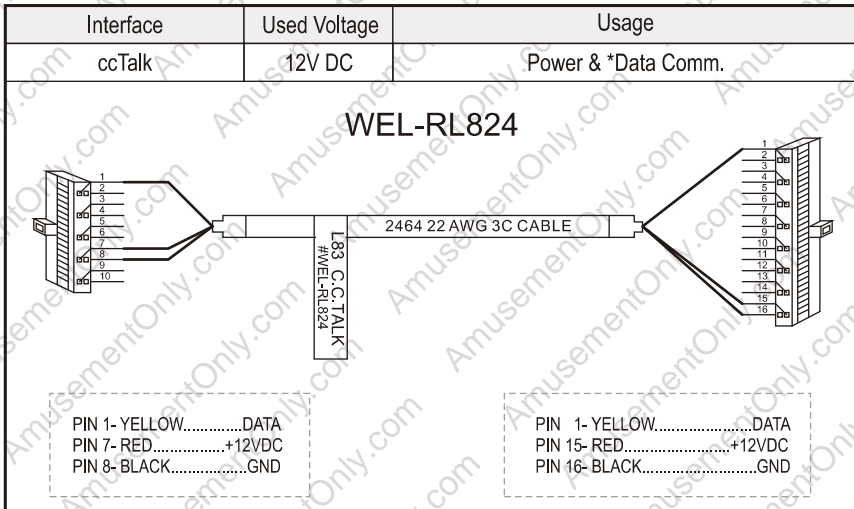

5-1 FIG.24

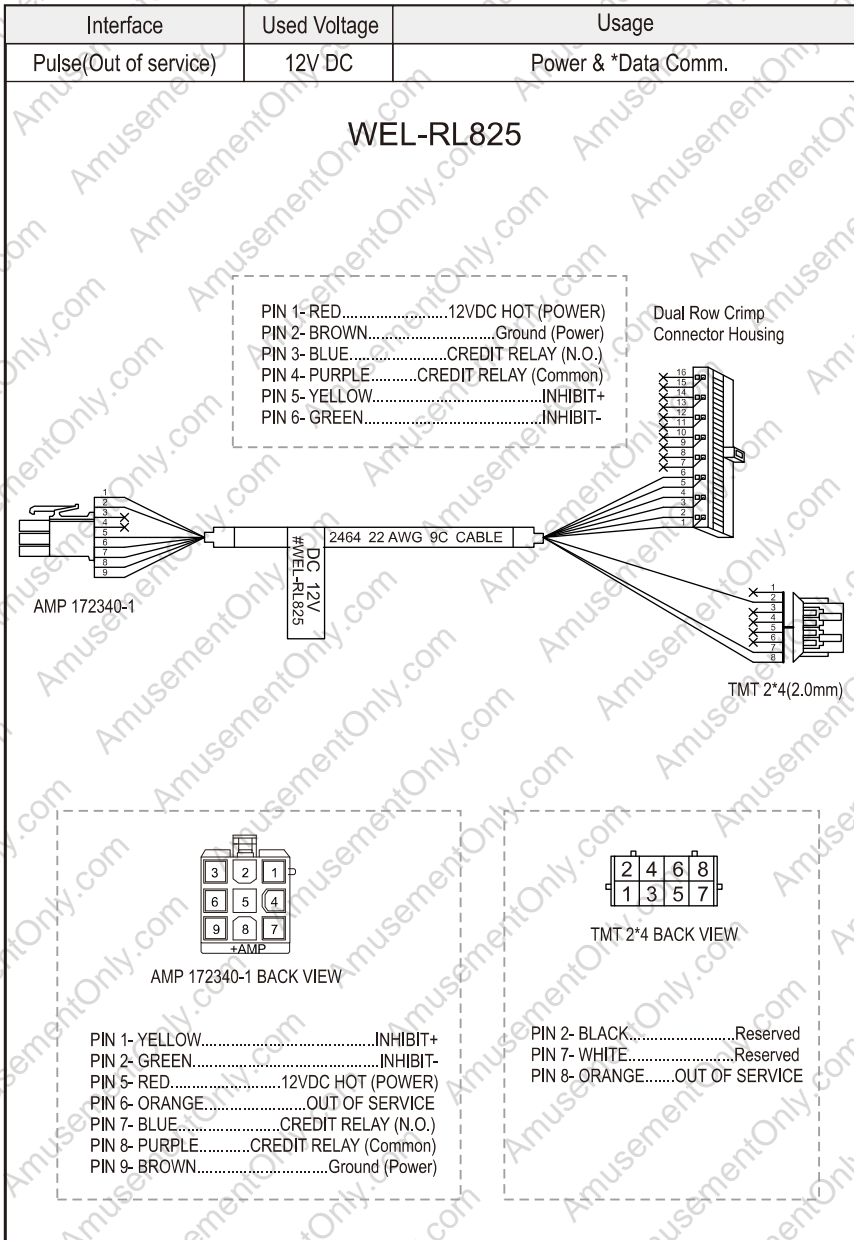

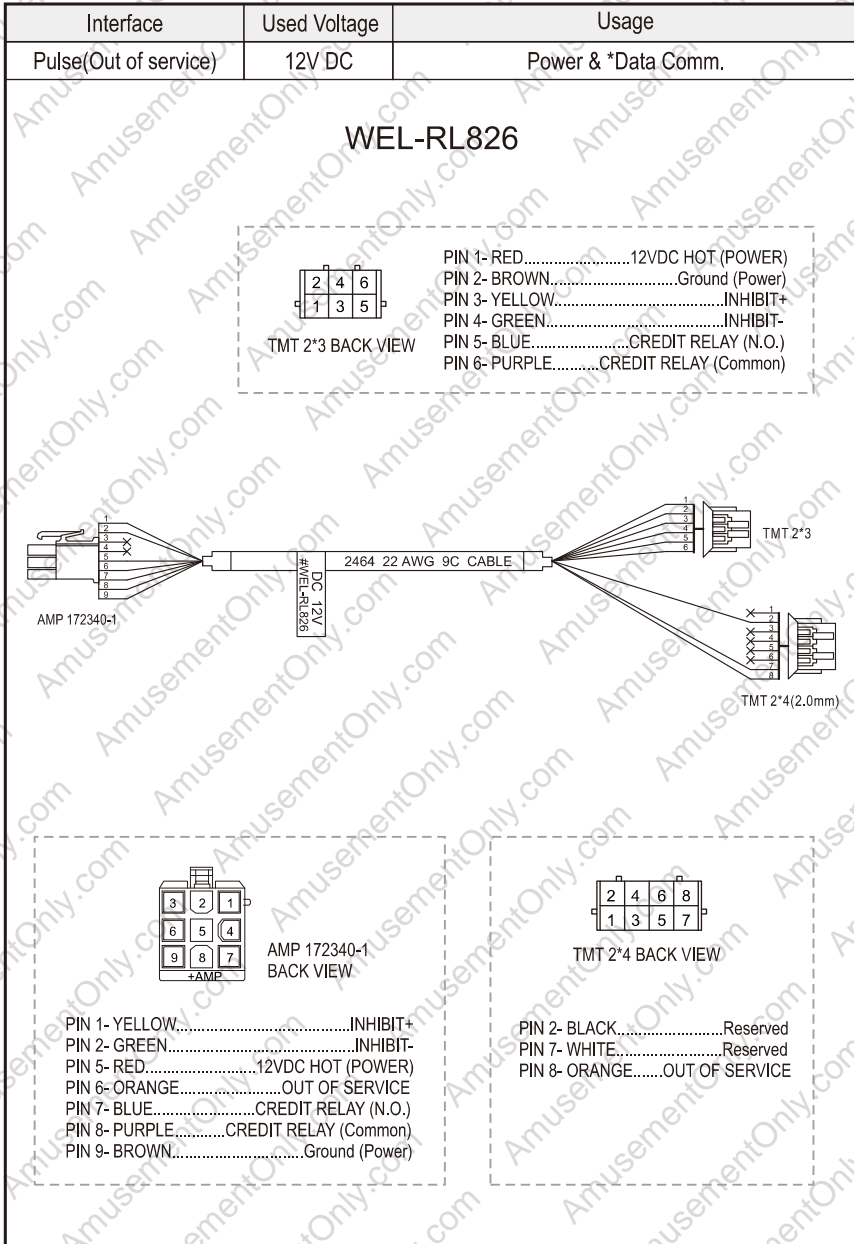

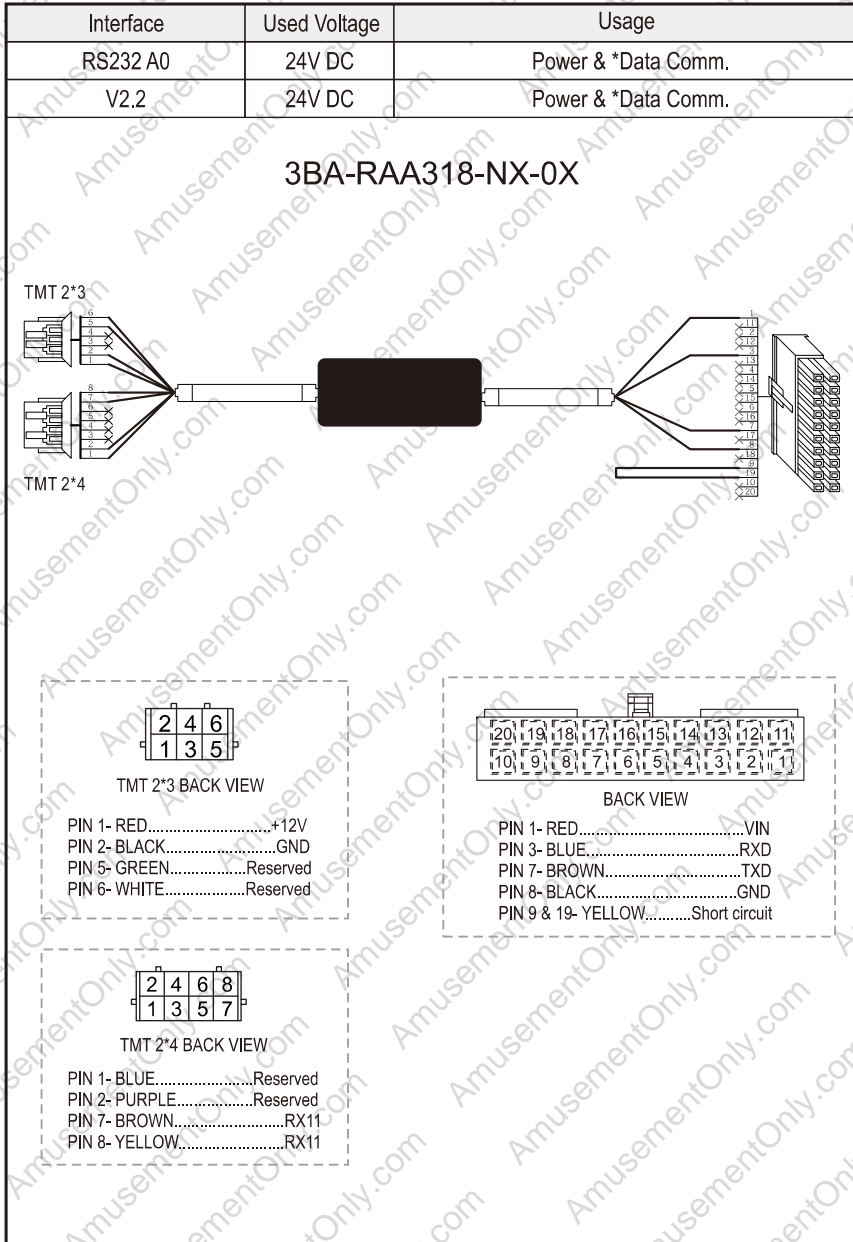

Interface	Used Voltage	Usage
ccTalk	12V DC	Extension Wire for WEL-RL803

IDC-RA10400

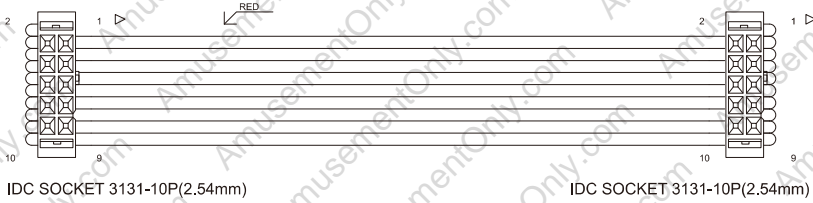

CNT-R7025

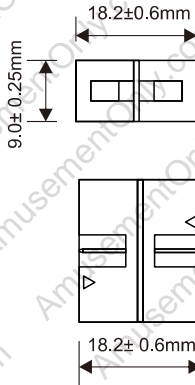

5-1-1. I/O Circuit Pulse Interface.

5-1-1 FIG. 01

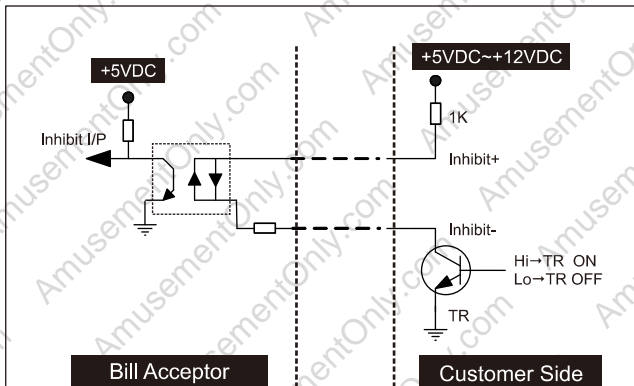
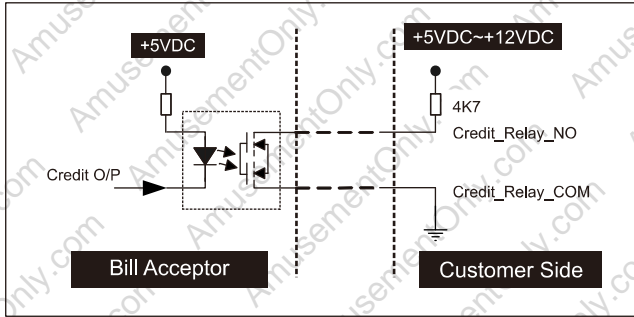

BA Status	*DIP SW Setting	Control Signal	
Inhibit	Inhibit Active	Low	Low
		High	High
Enable	Inhibit Active	Low	High
		High	Low

*Note: Please refer to DIP Switch Setting Guide for detail.

RS232, RS232 A0, RS232 A1, ccNet compatible Interface.

5-1-1 FIG. 02

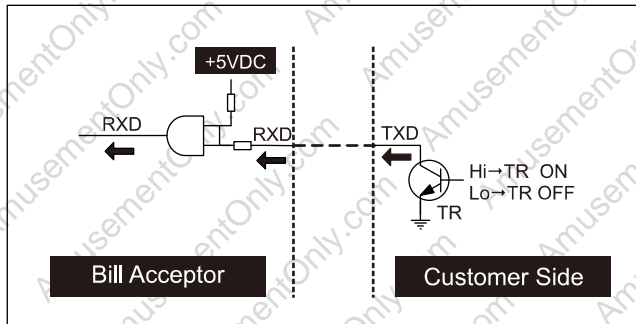
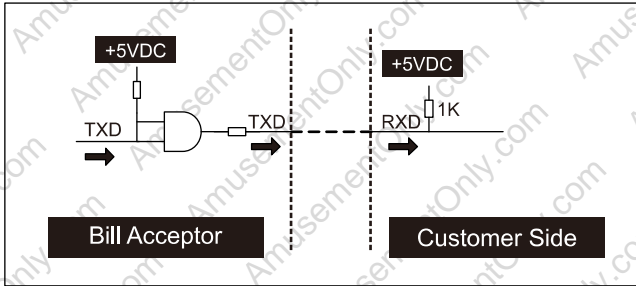

MDB Interface.

5-1-1 FIG. 03

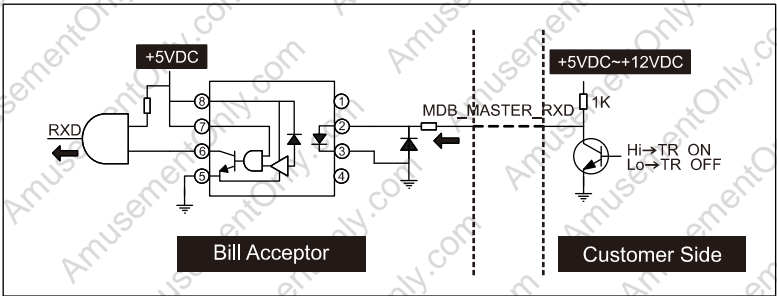
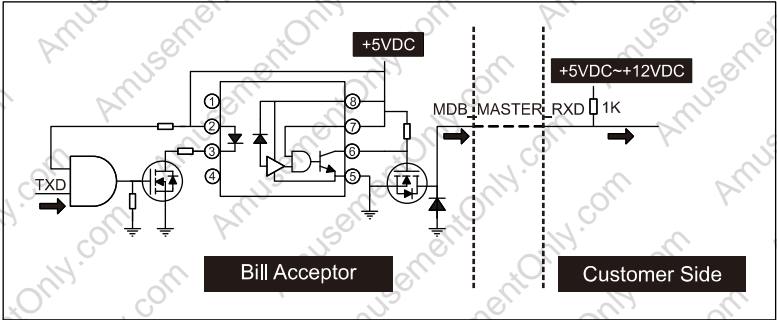

Parallel A1 Interface.

5-1-1 FIG. 04

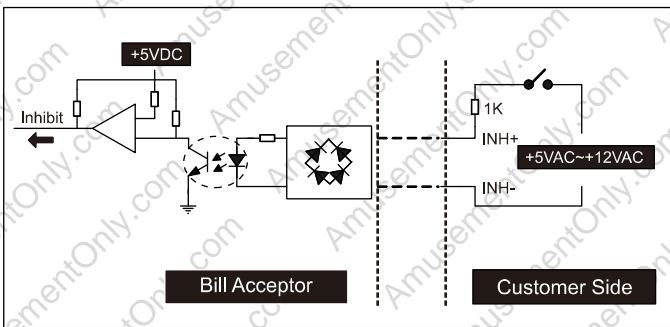
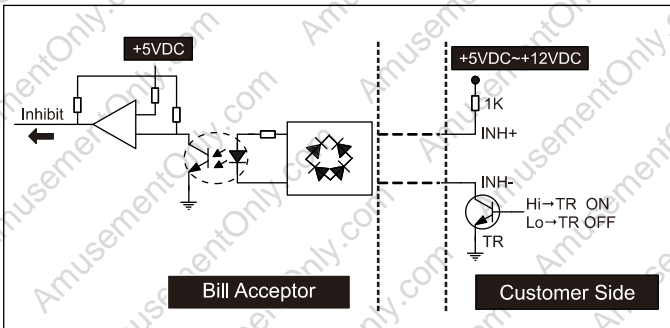
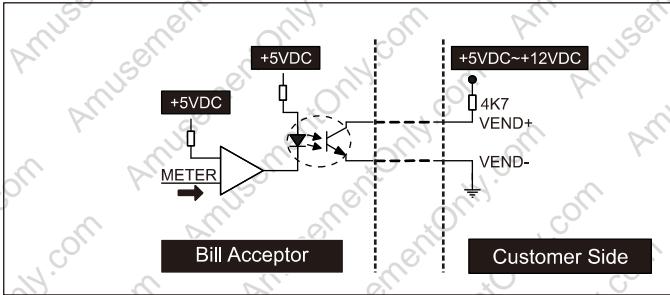

Parallel Interface.

5-1-1 FIG. 05

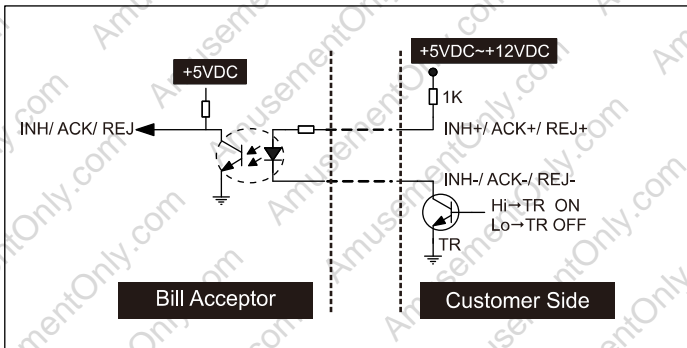
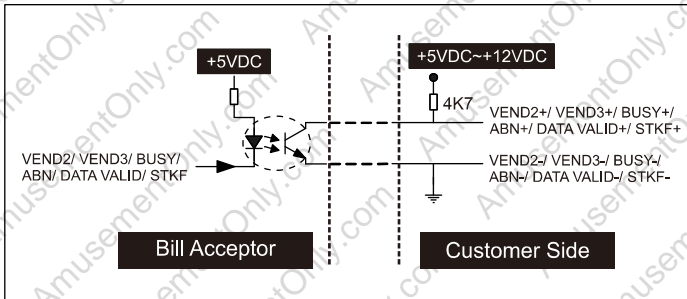
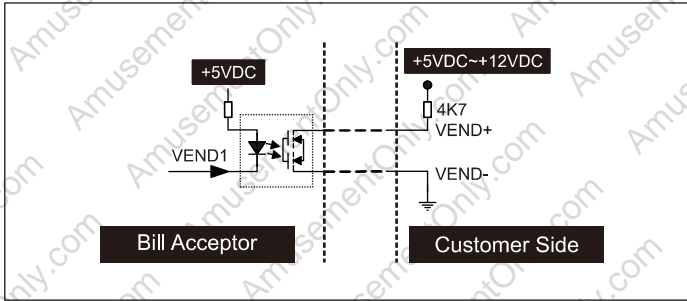

ccTalk Interface.

5-1-1 FIG. 06

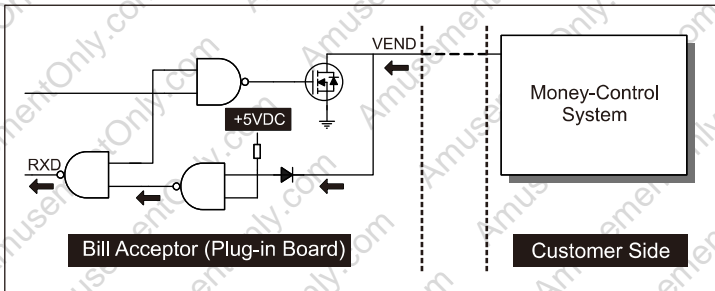
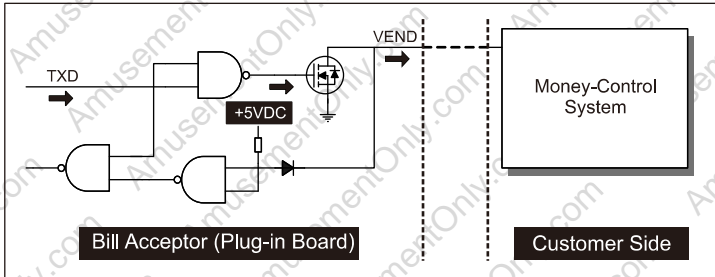

L70T-P5, L77T-P5:
RS232 A0 & V2.2 Interface.

5-1-1 FIG. 07

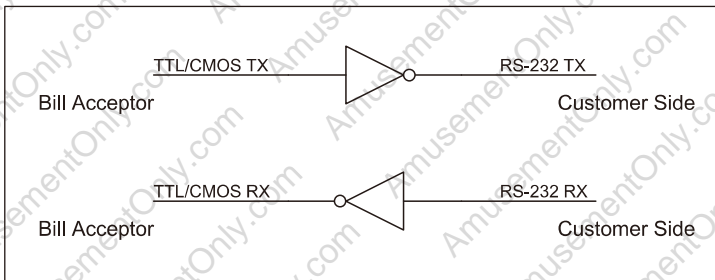

5-2. DIP Switch Setting

There is one serial DIP switches which are set on the side of L Series(as FIG.01). According to different currencies which are used by users, DIP switch settings could be varied to fit users' needs. Besides, there's another serial DIP switches at the bottom of L series for interface setting(as FIG.02). Please refer to " L Series DIP Switch Setting Guide " in the package for more details.

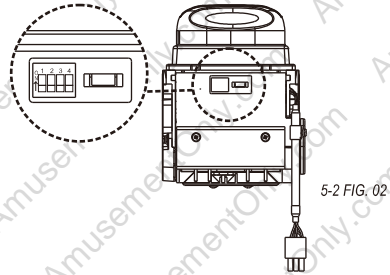
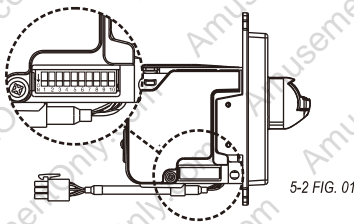

5-3. Software Download and Upgrade

To download and upgrade the software to L Series, the programmer (FP-004) is needed. Please contact ICT to purchase(FP-004) and refer to FP-004 user guide for software download and upgrade information.

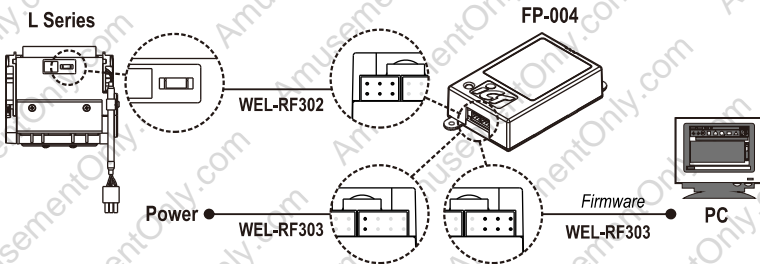

Turn on Bill Acceptor after connecting.

6. Maintenance

To make sure the bill acceptor always works smoothly, please clean the internal parts regularly.

To clean the internal parts:

1. Turn bill acceptor off.
2. Press buttons to open LED assembly.
3. Use soft cloth or cotton swab to clean internal parts and bill path.

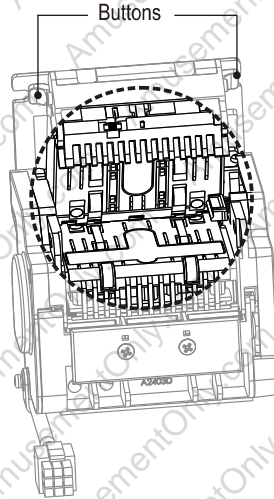

6 FIG. 01



Maintenance Notice

(Any improper maintenance will result invalid warranty.)

Recommended

Mild, non-abrasive, soap water.

DO NOT USE

Organic solvent , Alcohol, Volatile liquid.

7. Troubleshooting

Bezel LED Errors

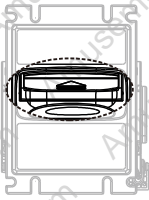

7 FIG. 01

L70#

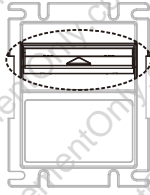

7 FIG. 02

L77F

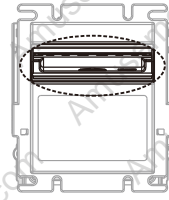

7 FIG. 03

L83

7 TABLE 01

LED Flashes		Status	Corrective Actions
Red	Green		
	1	White Card Calibration	Please calibrate with ICT white calibration card.
1		Bill jammed.	Open bill path unit and then remove the jammed bill.
2		Disable.	Inspect the right DIP switch setting.
3		Recognition sensor module error.	Inspect the foreign objects on sensor or bill path and clean.
3+2		Hook sensor error.	Inspect the foreign objects on security hook and clean.
3+4		Fish sensor error	Inspect the foreign objects on sensor or bill path and clean.
4		A stringing attempt has detected.	Inspect the foreign objects on sensor or bill path and clean.
5		Bill box has been removed. (L83 with bill box only)	Replace the bill box.
6		Stacker error or stacker full. (for modules with bill box only).	Empty the bill box.
7		Motor error.	Inspect the foreign objects on bill path and clean.



If the error can not be solved after corrective actions or happen again, please contact ICT for technical support.

ccTalk Information

- Manufacturer ID: ICT
- Equipment Category ID: Bill Acceptor
- Product Code: L83/ L77F/ L70F/ L70T/ L77T
- Serial Number: According to last 8 digits of production serial number.

Default: 12345678

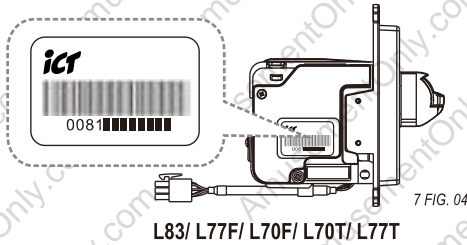

- Software Revision: According to the software revision number.

Ex. L8DX06HAH10N241EU720

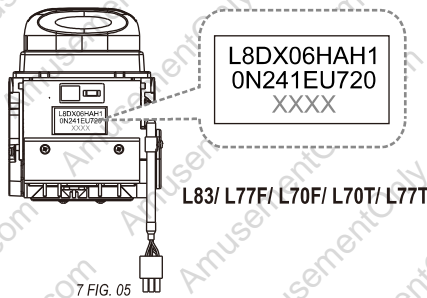

- Encryption Mode Password: Default as 123456
(command changeable).



Please contact ICT for more information.



Taiwan

International Currency Technologies Corporation

No.28, Ln. 15, Sec. 6, Minquan E. Rd., Neihu Dist., Taipei City 114, Taiwan

sales@ictgroup.com.tw (For Sales)

fae@ictgroup.com.tw (For Customer Service)

Website: www.ictgroup.com.tw

