



www.ictgroup.com.tw

Coin Sorter for UCA Series



Installation Guide

International Currency Technologies Corp.

Use of Materials Limitations

International Currency Technologies Corporation (ICT) all rights reserved.

All materials contained are the copyrighted property of ICT.

All trademarks, service marks, and trade names are proprietary to ICT.

ICT reserves the right at all times to disclose or to modify any information as ICT deems necessary to satisfy any applicable law, regulation, legal process or governmental request, or to edit, refuse to post or to remove any information or materials, in whole or in part, in ICT's sole discretion.

Coin Sorter for UCA

Contents

1. Introduction

1-1. Overview.....	2
1-2. Features.....	2

2. Specifications.....3

3. Packing List.....3

4. Dimension.....4

5. Installation

5-1. Harness Application.....	5
5-2. How to install Coin Sorter on UCA Series.....	6
5-3. How to setup coin sorting channels.....	7

6. Maintenance.....8

7. Troubleshooting

7-1. How to remove jammed coins.....	9
--------------------------------------	---

Coin Sorter for UCA

1. Introduction

1-1. Overview

Coin Sorter is designed for combining with UCA Series coin acceptor product, it can sort up to four different coins at the same time while accepting multiple coins from UCA Series, and provide you the most convenient service.

1-2. Features

- Four different coins sorting service at the same time.
- Simple installation to save your time.
- Easy to use; no software program setup needed.
- Service life is up to 300,000 times.

Coin Sorter for UCA

4. Dimension

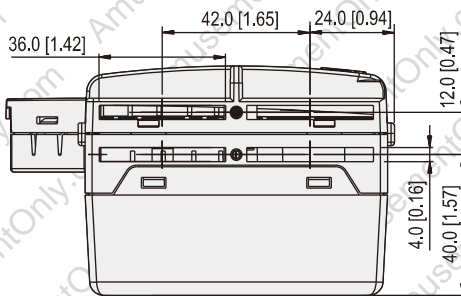
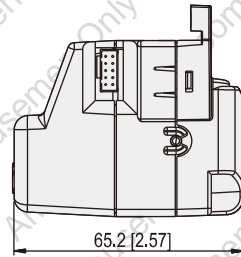
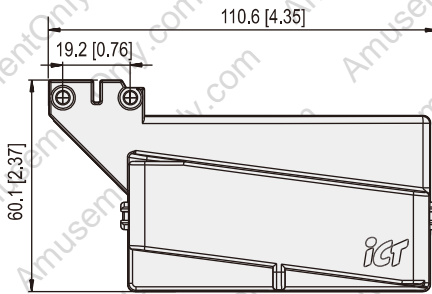
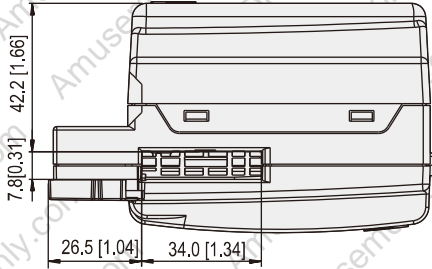

Unit : mm [inch]

4 FIG.01

5. Installation

5-1. Harness Application

5-1 FIG.01

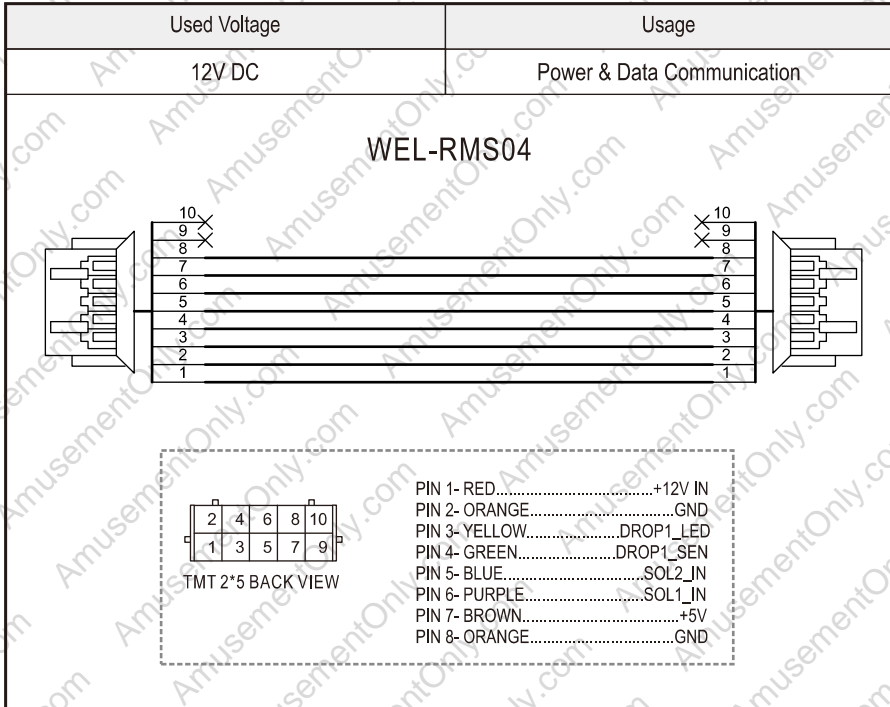

Coin Sorter for UCA

5-2. How to install Coin Sorter on UCA Series?

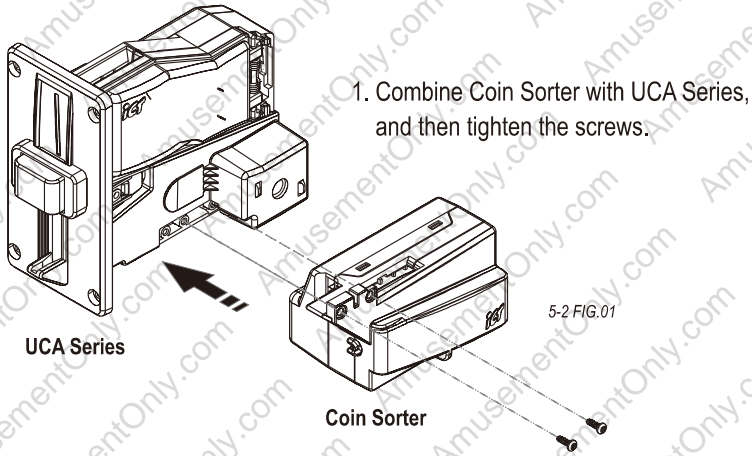

2. Connect Coin Sorter to UCA Series with WEL-RMS04.

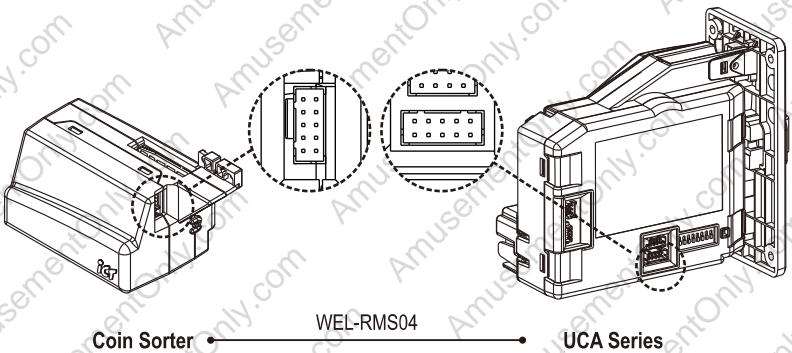

5-2 FIG.02

Coin Sorter for UCA

5-3. How to setup coin sorting channels ?

To setup coin sorting channels, please purchase FP-001 from ICT.

1. Connect FP-001 to UCA Series and PC.

Power must be applied to UCA Series after connecting.

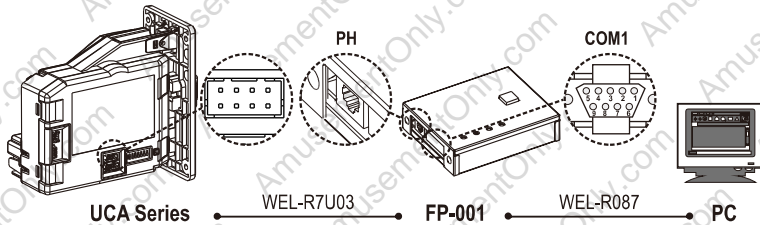

2. Download UCA tool from www.ictgroup.com.tw/ → support

Start UCA tool and check the COM port status.

3. Click  to get current setting in UCA Series.

4. Select Sorter channel.

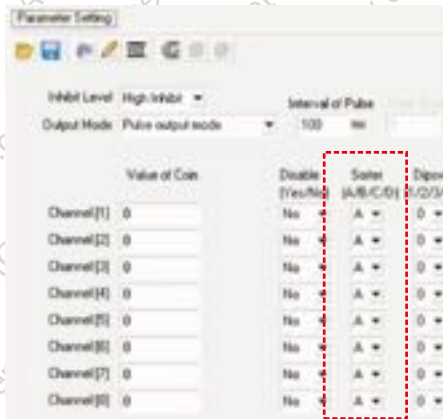

5-3 FIG.01

5. Click  to update the new channel.

Coin Sorter for UCA

6. Maintenance

To make sure Coin Sorter always works smoothly, please clean the internal parts regularly.

To clean the internal parts:

1. Insert a flathead screwdriver into the gap on Coin Sorter, then turn the flathead screwdriver to open Coin Sorter.

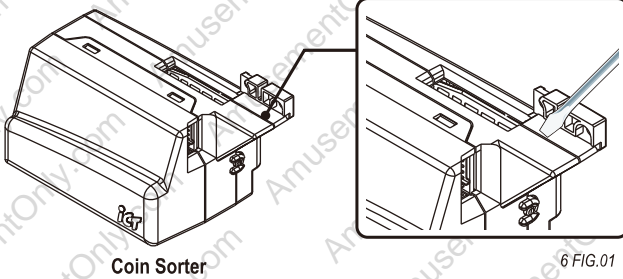

2. Clean the prism units and lens with a soft, dry cloth or towel.

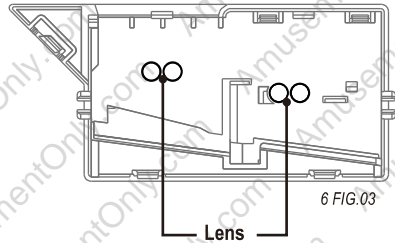
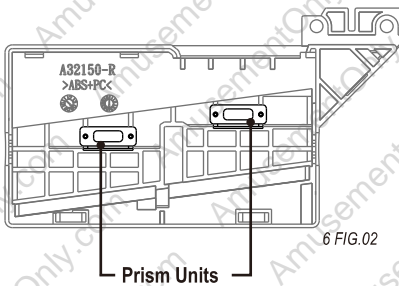

	Maintenance Notice (Any improper maintenance will invalidate warranty.)	
	Recommended	Mild, non-abrasive, soap water.
DO NOT USE	Organic solvent , Alcohol, Volatility liquid.	

7. Troubleshooting

7-1. How to remove jammed coins?

To remove jammed coins:

1. Insert a flathead screwdriver into the gap on Coin Sorter, then turn the flathead screwdriver to open Coin Sorter.

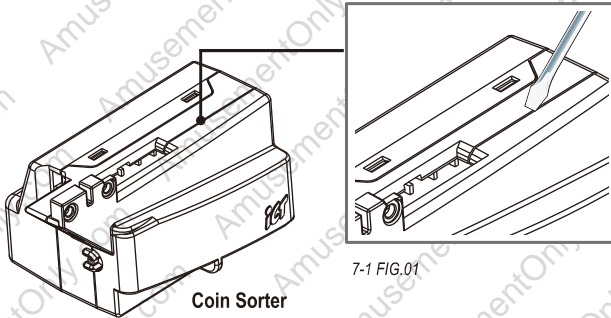

2. Remove jammed coins from the area as below.

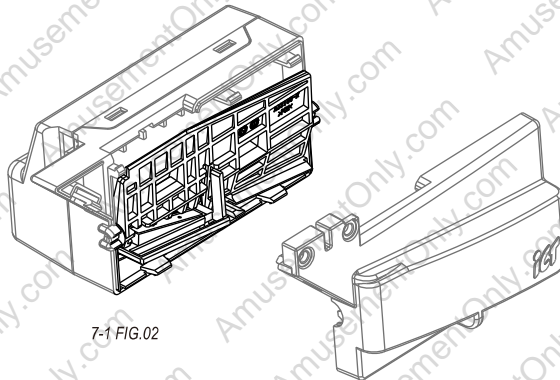

If the error can not be solved after corrective actions or it recurs, please contact ICT for technical support.



Taiwan

International Currency Technologies Corporation

No.28, Ln. 15, Sec. 6, Minquan E. Rd., Neihu Dist., Taipei City 114, Taiwan

sales@ictgroup.com.tw (For Sales)

fae@ictgroup.com.tw (For Customer Service)

Website: www.ictgroup.com.tw

