



Card Vending Dispenser

**CVD** Series

Installation Guide



International Currency Technologies

## **Use of Materials Limitations**

International Currency Technologies Corporation (ICT) all rights reserved.

All materials contained are the copyrighted property of ICT.

All trademarks, service marks, and trade names are proprietary to ICT.

ICT reserves the right at all times to disclose or to modify any information as ICT deems necessary to satisfy any applicable law, regulation, legal process or governmental request, or to edit, refuse to post or to remove any information or materials, in whole or in part, in ICT's sole discretion.

## Contents

<b>1. Introduction</b>	
1-1. Overview.....	2
1-2. Features.....	2
<b>2. Specifications</b> .....	3
<b>3. Packing List</b> .....	4
<b>4. Dimensions</b> .....	5
<b>5. Installation</b>	
5-1. Main Board.....	7
5-2. Harness Application.....	8
5-2-1. Pin Assignment.....	10
5-2-2. I/O Circuits.....	14
5-3. DIP Switch Setting.....	17
5-4. Time Chart.....	19
5-5. Communication Protocol.....	25
<b>6. Operation</b>	
6-1. How to adjust thickness of cards.....	26
6-2. How to fill cards.....	27
6-3. Low Level Sensor Function.....	28
<b>7. Maintenance</b> .....	30
<b>8. Troubleshooting</b> .....	30

# **1. Introduction**

## **1-1. Overview**

CVD & CVD2 is a card vending dispenser which is based on the design of CVD series. The machine features low level sensor function with Standard type or Drop type as a reliable card dispenser which is able to work steadily and fast approx.1 second per card.

## **1-2. Features**

- Low level sensor function (optional).
- Cards easy filling.
- Pulse, Hopper, and RS232 Interface Available.
- 12V and 24V acceptable.
- Card capacity available from 300 to 1000 cards.
- Standard and Drop type card dispenser available.

## 2. Specification

### **General**

Card Dispensing Time	Approx. 1 second/ card
Interface	Hopper, Pulse, RS232

### **Electrical**

Power Source	12V DC (11.4~12.6V DC) 24V DC (22.8~25.2V DC)
Power Consumption	12V- Standby : 0.25A, 3W Operation: 1.25A, 15W Maximum: 2.5 A, 30W 24V- Standby : 0.13A, 3.2W Operation: 0.83A, 20W Maximum: 1.66A, 40W

Operation Environment	Operation Temperature: 0°C~50°C Storage Temperature: -30°C~70°C Humidity: 30%~90% RH(non-condensation)
-----------------------	--

### **Mechanical**

Dispensing Way	Standard Type : CVD & CVD2 [ 300 E/ EH/ ER/ EL/ ELR] CVD & CVD2 [1000 E/ EH/ ER/ EL/ ELR] _____ Card will be held in slot when dispensing.
----------------	---

	Drop Type : CVD & CVD2 [ 300 DE/ DEL/ DELR] CVD & CVD2 [1000 DE/ DEL/ DELR] _____ Card will be dropped out from slot when dispensing.
--	--

## CVD Series

### Applicable Cards

Material: Plastic, Paper Cards (Opaque)

Size: Thickness 0.2~1.0mm(max.)

Width 53~58 ±0.5mm

Length 76~90 ±0.5mm

### Outline Dimension

Standard Type: Refer to page.5

Drop Type: Refer to page.6

### Card Capacity

CVD & CVD2 [ 300 Series]: Approx. 300 Cards

CVD & CVD2 [1000 Series]: Approx.1000 Cards  
(a card thickness of 0.2mm)

### Weight

CVD & CVD2 [ 300 Series]: Approx.1.9kg

CVD & CVD2 [1000 Series]: Approx.3.2kg

### Install Angle

Vertical

### Installation

**Indoor use only!**

## 3. Packing List

### Main

Card Vending Dispenser

### Accessory

CVD Series Installation Guide

Harness: Refer to 5-2

## 4. Dimensions

Standard Type <CVD & CVD2> [300/1000 E/ EH/ ER]

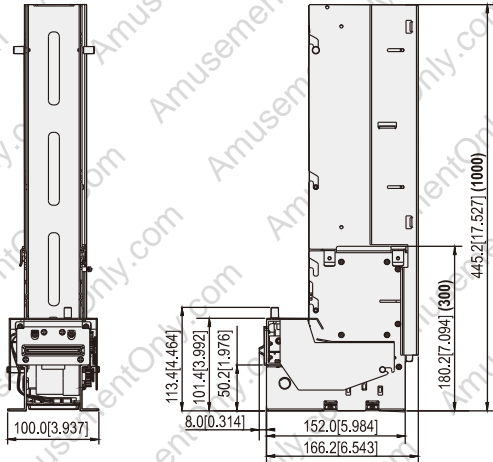

Unit : mm [ inch ]  
4 FIG.01

With Low Level Sensor [300/1000 EL/ ELR]

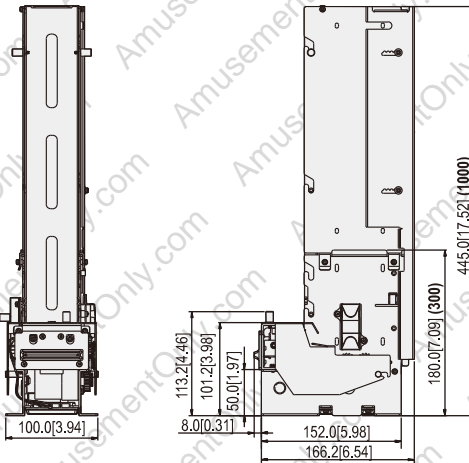

Unit : mm [ inch ]  
4 FIG.02

Drop Type <CVD & CVD2> [300/1000 DE]

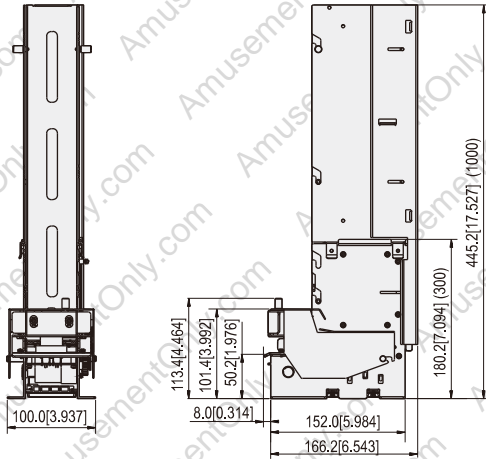

Unit : mm [ inch ]

4 FIG.03

With Low Level Sensor [300/1000 DEL/ DELR]

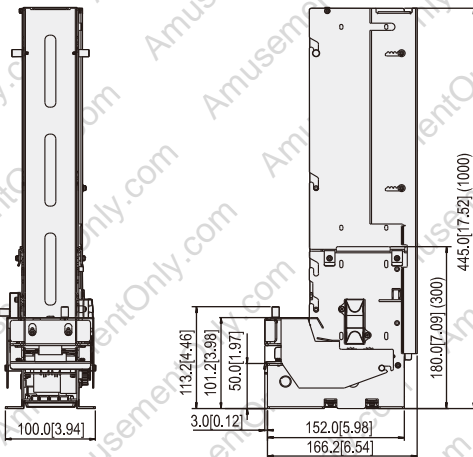

Unit : mm [ inch ]

4 FIG.04

## 5. Installation

### 5-1. Main Board

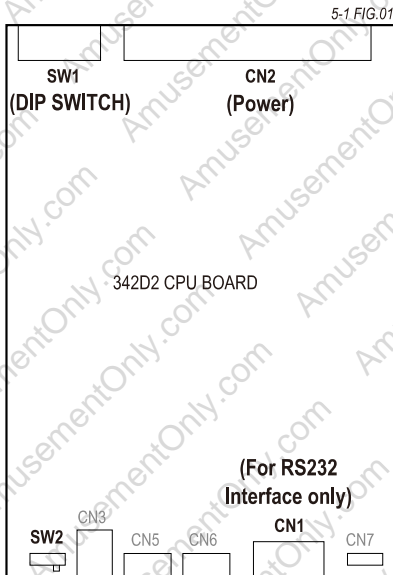

RUN | LOAD

**RUN:** Operation mode(Manufacture setting)  
**LOAD:** Firmware Upgrade mode

#### Power Supply.

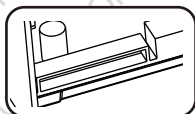

Connect to WEL-RC601  
 (Refer to page.8)

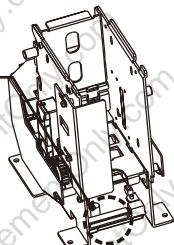

5-1 FIG.02

#### RS232 Only.

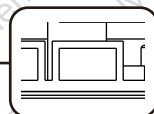

Connect to WEL-R7U06-2  
 (Refer to page.9)

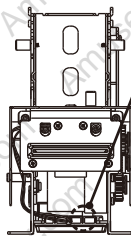

5-1 FIG.03

## 5-2. Harness Application

5-2 FIG.01

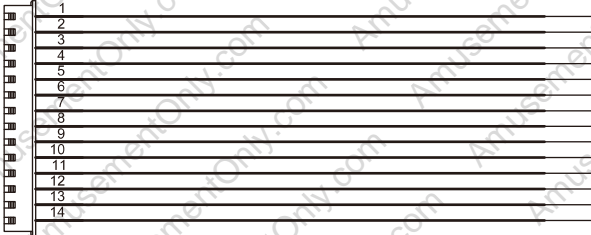
Interface	Used Voltage	Usage														
Pulse	12V DC	Power & Data Communication														
<b>WEL-RC601</b>																
<p>XH-14P(2.5mm)</p> 																
<table style="width: 100%; border-collapse: collapse;"> <tbody> <tr> <td style="width: 50%;">PIN 1- GND.....BLACK</td> <td style="width: 50%;">PIN 8- OUTPUT SIGNAL.....BLUE</td> </tr> <tr> <td>PIN 2- +24V.....ORANGE</td> <td>PIN 9- VCC.....PURPLE</td> </tr> <tr> <td>PIN 3- GND.....BLACK</td> <td>PIN 10- OUTPUT SIGNAL.....GRAY</td> </tr> <tr> <td>PIN 4- CARD_DATA.....BROWN</td> <td>PIN 11- VCC.....WHITE</td> </tr> <tr> <td>PIN 5- CARD_RESET.....YELLOW</td> <td>PIN 12- EMPTY_O.....PINK</td> </tr> <tr> <td>PIN 6- GND.....BLACK</td> <td>PIN 13- GND.....BLACK</td> </tr> <tr> <td>PIN 7- VCC.....GREEN</td> <td>PIN 14- +12V.....RED</td> </tr> </tbody> </table>			PIN 1- GND.....BLACK	PIN 8- OUTPUT SIGNAL.....BLUE	PIN 2- +24V.....ORANGE	PIN 9- VCC.....PURPLE	PIN 3- GND.....BLACK	PIN 10- OUTPUT SIGNAL.....GRAY	PIN 4- CARD_DATA.....BROWN	PIN 11- VCC.....WHITE	PIN 5- CARD_RESET.....YELLOW	PIN 12- EMPTY_O.....PINK	PIN 6- GND.....BLACK	PIN 13- GND.....BLACK	PIN 7- VCC.....GREEN	PIN 14- +12V.....RED
PIN 1- GND.....BLACK	PIN 8- OUTPUT SIGNAL.....BLUE															
PIN 2- +24V.....ORANGE	PIN 9- VCC.....PURPLE															
PIN 3- GND.....BLACK	PIN 10- OUTPUT SIGNAL.....GRAY															
PIN 4- CARD_DATA.....BROWN	PIN 11- VCC.....WHITE															
PIN 5- CARD_RESET.....YELLOW	PIN 12- EMPTY_O.....PINK															
PIN 6- GND.....BLACK	PIN 13- GND.....BLACK															
PIN 7- VCC.....GREEN	PIN 14- +12V.....RED															

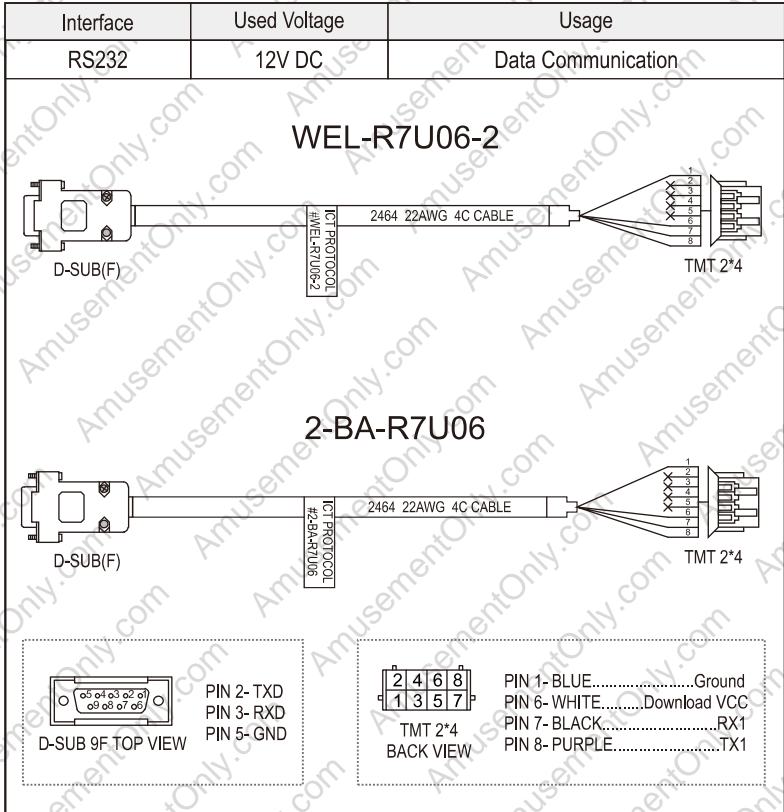

## 5-2-1. Pin Assignment

**Pulse/ Hopper Signal Mode**

&lt; For E/DE models only &gt; Harness: WEL-RC601

5-2-1 TABLE01

Pin	Assign	Function		Harness Color
1	CN_ 1	POWER SUPPLY	GND	BLACK
2	CN_ 2	POWER SUPPLY(option)	+24V	ORANGE
3	CN_ 3	POWER SUPPLY	GND	BLACK
4	CN_ 4	CARD_DATA	Input signal controller	BROWN
5	CN_ 5	CARD_RESET	Input signal controller	YELLOW
6	CN_ 6	POWER SUPPLY	GND	BLACK
7	CN_ 7	VCC	Ouput DC+5V	GREEN
8	CN_ 8	BUSY_O (for E models only)	Ouput signal controller	BLUE
		READY_O (for DE models only)		
9	CN_ 9	VCC	Ouput DC+5V	PURPLE
10	CN_10	READY_O (for E models only)	Ouput signal controller	GRAY
		BUSY_O (for DE models only)		
11	CN_11	VCC	Ouput DC+5V	WHITE
12	CN_12	ERROR_O AND EMPTY_O	Ouput signal controller	PINK
13	CN_13	POWER SUPPLY	GND	BLACK
14	CN_14	POWER SUPPLY(option)	+12V	RED

Note: Can be selected +12V or +24V.

< For EH models only > Harness: WEL-RC601

5-2-1 TABLE 02

Pin	Assign	Function		Harness Color
1	CN_1	POWER SUPPLY	GND	BLACK
2	CN_2	POWER SUPPLY(option)	+24V	ORANGE
3	CN_3	POWER SUPPLY	GND	BLACK
4	CN_4	CARD_DATA	Dispensing signal	BROWN
5	CN_5	CARD_RESET	Input signal controller	YELLOW
6	CN_6	POWER SUPPLY	GND	BLACK
7	CN_7	VCC	Ouput DC+5V	GREEN
8	CN_8	CREDIT	Ouput signal controller	BLUE
9	CN_9	VCC	Ouput DC+5V	PURPLE
10	CN_10	N/A	N/A	GRAY
11	CN_11	VCC	Ouput DC+5V	WHITE
12	CN_12	ERROR_O AND EMPTY_O	Ouput signal controller	PINK
13	CN_13	POWER SUPPLY	GND	BLACK
14	CN_14	POWER SUPPLY(option)	+12V	RED

Note: Can be selected +12V or +24V.

< For Low Level Sensor models only > Harness: WEL-RC601

5-2-1 TABLE 03

Pin	Assign	Function		Harness Color
1	CN_1	POWER SUPPLY	GND	BLACK
2	CN_2	POWER SUPPLY(option)	+24V	ORANGE
3	CN_3	POWER SUPPLY	GND	BLACK
4	CN_4	CARD_DATA	Dispensing signal	BROWN
5	CN_5	CARD_RESET	Input signal controller	YELLOW
6	CN_6	POWER SUPPLY	GND	BLACK
7	CN_7	VCC	Ouput DC+5V	GREEN
8	CN_8	CREDIT	Ouput signal controller	BLUE
9	CN_9	VCC	Ouput DC+5V	PURPLE
10	CN_10	LOW LEVEL SIGNAL	Ouput signal controller	GRAY
11	CN_11	VCC	Ouput DC+5V	WHITE
12	CN_12	ERROR_O AND EMPTY_O	Ouput signal controller	PINK
13	CN_13	POWER SUPPLY	GND	BLACK
14	CN_14	POWER SUPPLY(option)	+12V	RED

Note: Can be selected +12V or +24V.

**RS232 Signal Mode**

Harness: WEL-RC601

5-2-1 TABLE 04

Pin	Assign	Function		Harness Color
1	CN_1	POWER SUPPLY	GND	BLACK
2	CN_2	POWER SUPPLY(option)	+24V	ORANGE
3	CN_3	POWER SUPPLY	GND	BLACK
4	CN_4	N/A	N/A	BROWN
5	CN_5	N/A	N/A	YELLOW
6	CN_6	POWER SUPPLY	GND	BLACK
7	CN_7	N/A	N/A	GREEN
8	CN_8	N/A	N/A	BLUE
9	CN_9	N/A	N/A	PURPLE
10	CN_10	N/A	N/A	GRAY
11	CN_11	N/A	N/A	WHITE
12	CN_12	N/A	N/A	PINK
13	CN_13	POWER SUPPLY	GND	BLACK
14	CN_14	POWER SUPPLY(option)	+12V	RED

Note: Can be selected +12V or +24V.

Harness: WEL-R7U06

5-2-1 TABLE 05

5-2-1 TABLE 05-1

Pin	Function	I/O	Harness Color
1	GND	N/A	BLUE
2	N/A	N/A	N/A
3	N/A	N/A	N/A
4	N/A	N/A	N/A

Pin	Function	I/O	Harness Color
5	N/A	N/A	N/A
6	+5V	O	WHITE
7	RXD	I	BLACK
8	TXD	O	PURPLE

## 5-2-2. I/O Circuits

### Hopper & Pulse Interface.

5-2-2 FIG.01

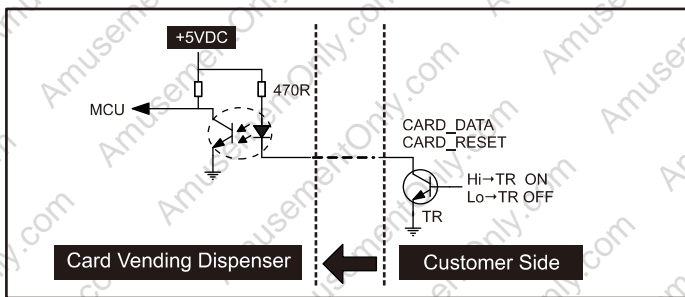
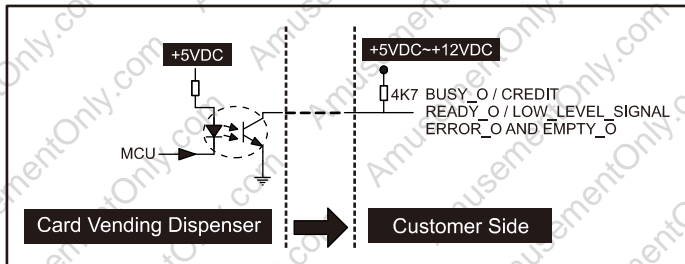

< EH Models only >

Hopper & Pulse Interface.

5-2-2 FIG.02

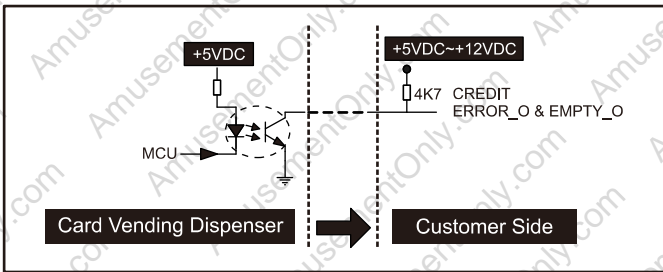
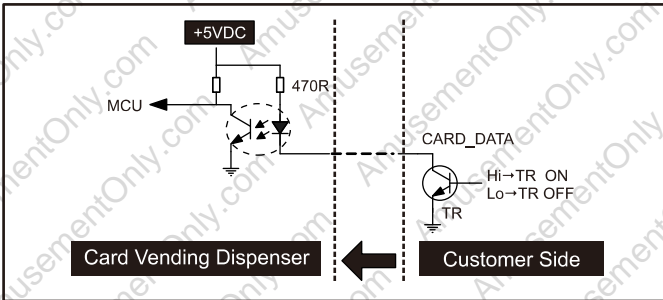

RS232 Interface.

5-2-2 FIG.03

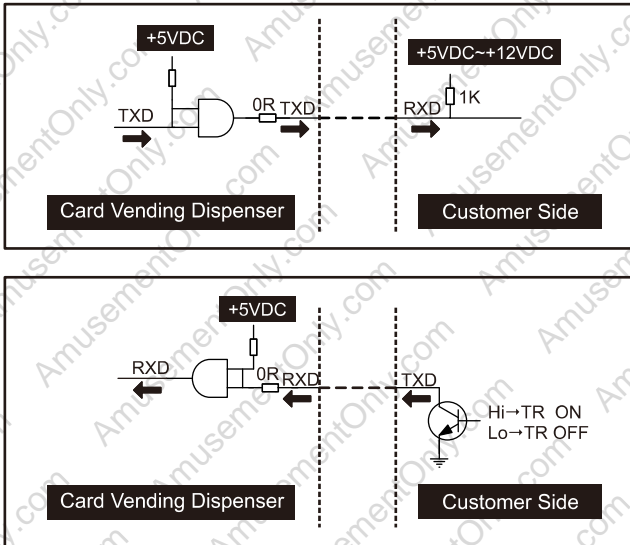

### 5-3. DIP Switch Setting

A serial DIP switches are set on rare CVD & CVD2 series (as FIG.01). According to different interfaces and other functions which are used by users, DIP switch settings could be varied to fit users' needs. For more information about DIP switch setting, please refer to the following charts.

#### Function Setting:

##### A. Retry Times Setting:

5-3 TABLE 01

Retry Times	SW1	SW2
1	OFF	OFF
★ 2	<b>ON</b>	<b>OFF</b>
4	OFF	ON
8	ON	ON

(★) Pulse Default.

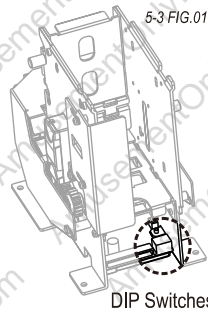

#### For Low Level sensor models only

##### B. Interface Setting:

Interface	SW3	SW4
Pulse	OFF	OFF
Hopper	OFF	ON
RS232	ON	OFF
N/A	ON	ON

5-3 TABLE 02

##### C. Card Dispenser Signal Setting:

Signal	SW5
★ <b>Normal Low (Active High)</b>	<b>OFF</b>
Normal High (Active Low)	ON

(★) Pulse Default.

5-3 TABLE 03

##### D. RS232 ID Setting:

RS232 ID	SW6	SW7
No.1 CVD Setting	OFF	OFF

5-3 TABLE 04

## E. Send credit mode:

	Send credit	SW8	
★	<b>Before card taking out</b>	<b>OFF</b>	(★) Default. 5-3 TABLE 05
	After card taking out	ON	

Note: For EL(Pulse, Hopper).

## For E models only

## B. Pulse Memory Setting

For Pulse Memory:(Max 20)

	Pulse Memory	SW3	SW4	
★	<b>Memory ON</b>	Reserved	<b>OFF</b>	(★) Pulse Default. 5-3 TABLE 06
	Memory OFF	Reserved	ON	

Note: Maximum 20 pulses per request. Any additional requests will be accumulated to maximum 20 pulses for card needs to be dispensed.

## For EH models only

## B. Card Dispenser Signal Setting:

	Signal	SW3	
★	<b>Normal Low (Active High)</b>	<b>OFF</b>	(★) Default. 5-3 TABLE 07
	Normal High (Active Low)	ON	

## C. Interface Setting:

	Interface	SW4	
★	<b>Hopper</b>	<b>OFF</b>	(★) Default. 5-3 TABLE 08
	Pulse(non-Memory)	ON	

## For ER models only

## B. RS232 ID Setting:

	RS232 ID	SW3	SW4	
	No.1 CVD Setting	OFF	OFF	5-3 TABLE 09

## 5-4. Time Chart

Pulse < For E Models only >

### Normal Card Dispensing

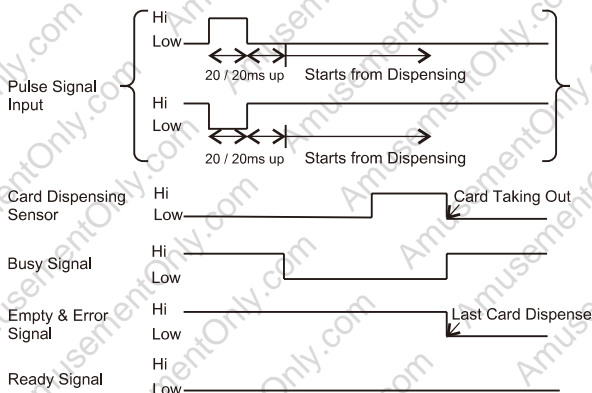

### Card Dispensing Disable

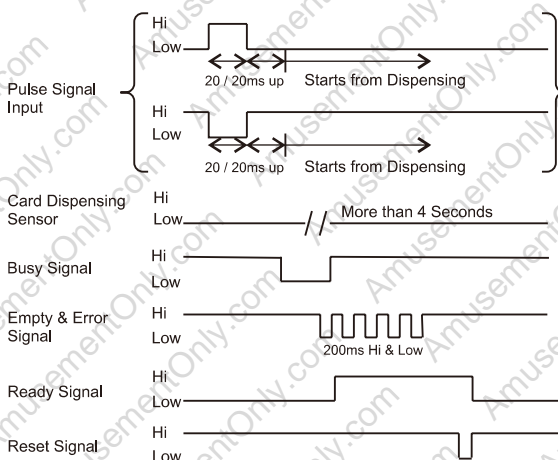

### Card Taking Forgotten

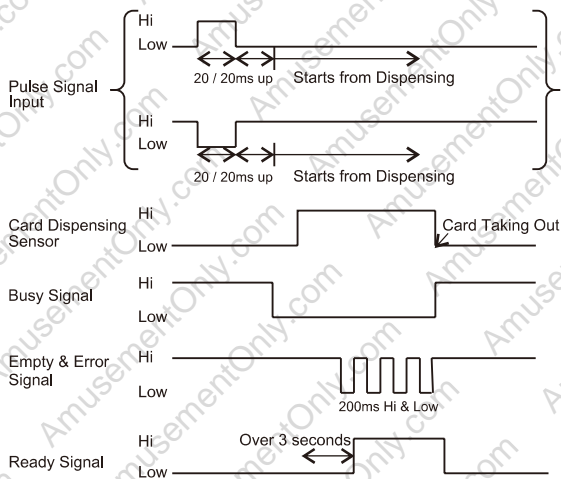

### Pulse <For EH Models only>

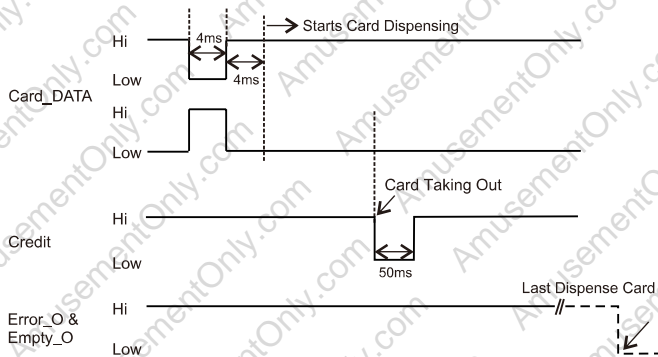

Hopper <For DE Models only>

**Normal Card Dispensing**

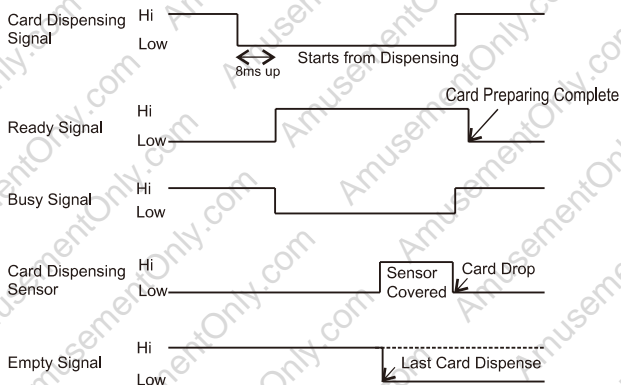

**Serial Card Dispensing**

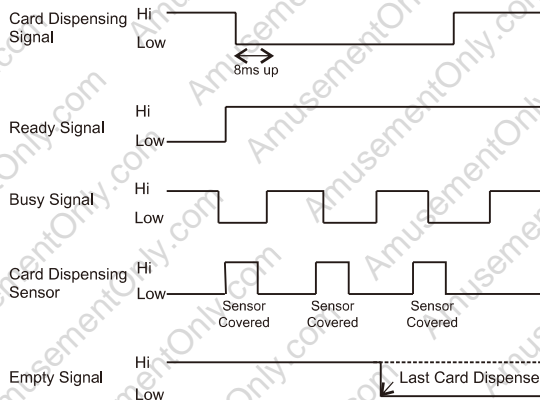

**Card Dispensing Disable**

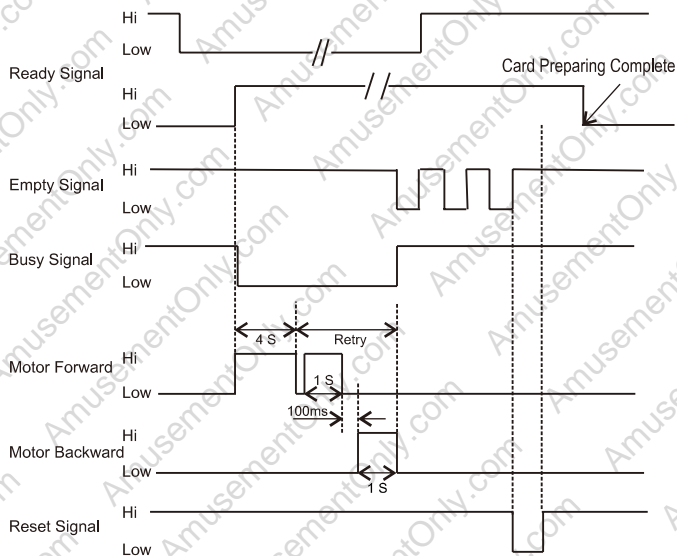

**Hopper <For EH Models only>**

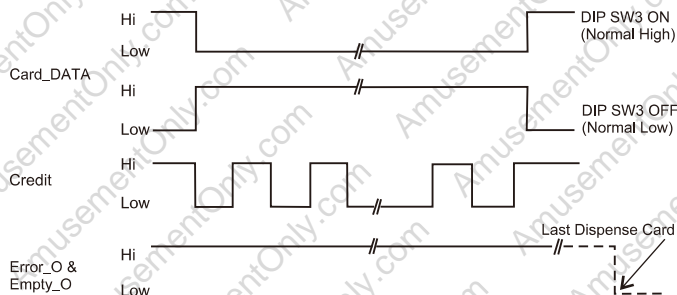

Pulse <For Low Level sensor Models only>

Normal Card Dispensing

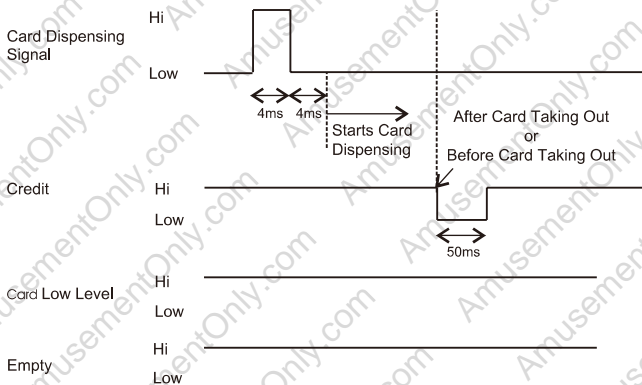

Card Low Level Detected after Dispensing

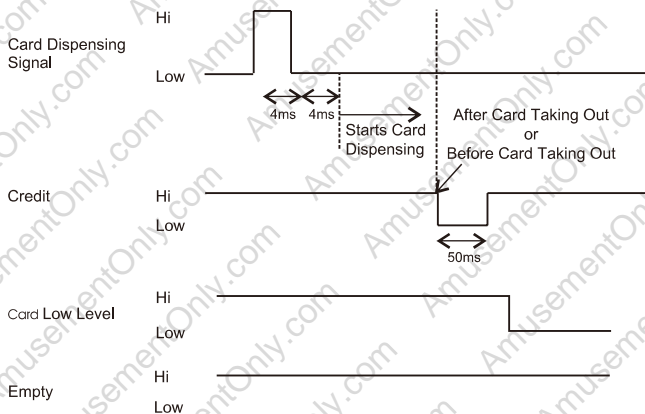

## Last Card Dispensing

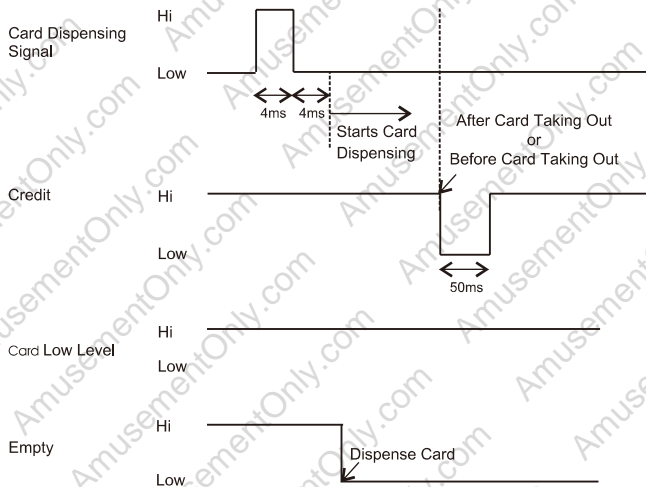

## 5-5. Communication Protocol

For RS232 Interface only

Baud rate: 9600, E, 8, 1

Byte1 : ID Number 1

Byte2 : CVD & CVD2 Request Status / CVD & CVD2 Command

Byte2		
Controller	Direction	CVD & CVD2
Request CVD Status(37H)	➔	Empty(22H) Ready(23H) Busy(24H)
	➜	Error(25H) Card Low Level(26H)
CVD Reset command(40H)	➔	
	➜	ACK(50H) NAK(4BH)
CVD Card Out(42H)	➔	
	➜	ACK(50H) NAK(4BH)

5-5 TABLE 01

Note:

1. Reset command is only accepted by CVD & CVD2 in error status.
2. As for CVD & CVD2 status inquiry, "Card Low Level" (26H) status shall be sent to controller instead of "Ready" (23H) status when low level sensor is triggered.

## 6. Operation

### 6-1. How to adjust thickness of cards

1. Loose two fixing-screws clockwise to move gate up/down.
2. Turn adjusting-screw clockwise to move the gate upward.
3. Put one sample card into gate and turn adjusting-screw simultaneously until the card can pass the gate smoothly.
4. Turn adjusting-screw clockwise (gate upward) few scales.

Thickness of a Card	Turning Scale
0.2 ~ 0.3mm	1 grid
0.4 ~ 0.5mm	2 grids
0.6 ~ 0.8mm	3 grids
0.9 ~ 1.0mm	4 grids

6-1 TABLE 01

5. Fasten the fixing-screws.

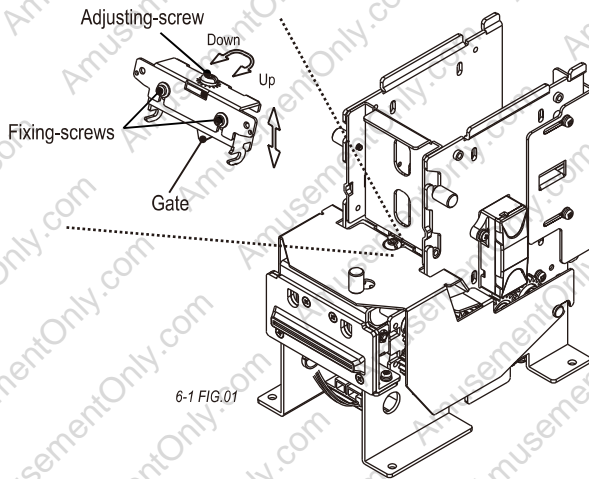

6-1 FIG.01

## 6-2. How to fill cards

### A. Fill cards from the front:

1. Loose manual screw, and take out door plate.
2. Take out weighting-plate.
3. Fill cards in.
4. Place weighting-plate on top of cards.
5. Put door plate back and tighten manual screw.

### B. Fill cards from the rear:

1. Take out weighting-plate.
2. Fill cards in.
3. Place weighting-plate on top of cards.

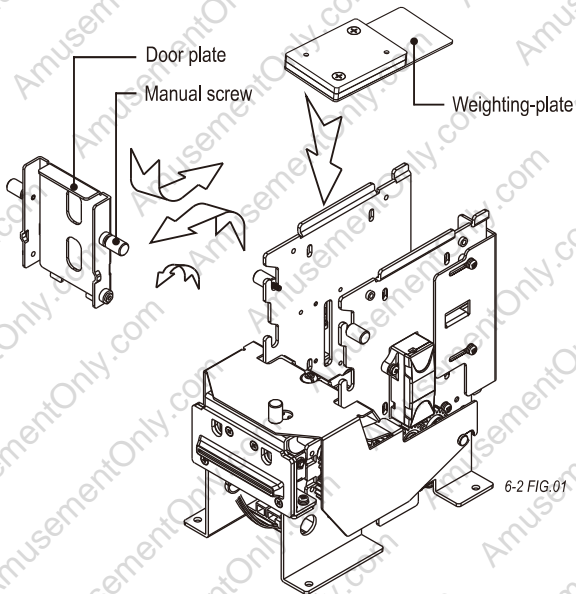

### 6-3. Low Level Sensor Function

The low level sensor is designed for CVD & CVD2 series to show low level status of cards. When the cards amount of CVD & CVD2 series is less than low level, the alert light will remind users re-filling cards up before card dispenser running out of cards.



**Low level should be set within five minutes after power is applied to CVD & CVD2 series (EL/ ELR/ DEL/ DELR).**

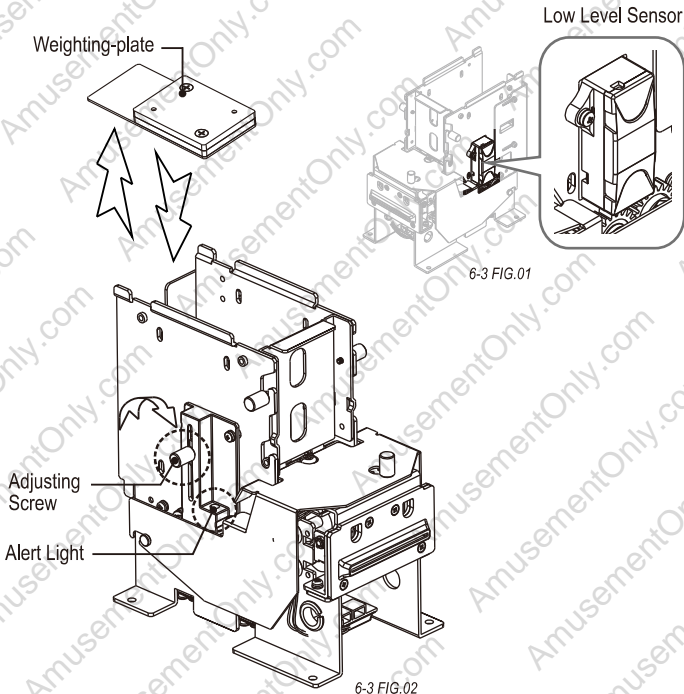

## Low Level Adjustment

To adjust low level cards:

1. Set up the amount of cards for low level to fit your needs.  
The acceptance thickness of low level is approx.10~60 cards.  
(According to card thickness 0.2mm)
2. Take weighting-plate out of the unit.
3. Put the amount of cards that you set up for low level in the unit. Then put weighting-plate back in the unit.
4. Clockwise tighten adjusting screw until alert light lights up to adjust the position of sensor.  
**Note:** For a flexible low level setup, ICT suggests you to save some space between weighting-plate and cards ( $\pm 2$  cards).
5. Put one more card in unit to turn alert light off. If the alert light is not off, please return to step 4 and do it again.
6. Low level sensor adjusting completely.



To keep sensor is always in position on the frames, do not loosen adjusting screw fiercely during adjusting.

## 7. Maintenance

Please follow the notice as below for routine maintenance:

<b>Maintenance Notice</b> <i>(Any improper maintenance will result invalid warranty.)</i>	
	<b>Recommended</b> <b>Mild, non-abrasive, soap water.</b>
<b>DO NOT USE</b>	<b>Organic solvent , Alcohol, Volatile liquid.</b>

## 8. Troubleshooting

Status	Corrective Actions
Card Dispensing Error	<ol style="list-style-type: none"> <li>1. Check if there is any error signals or empty signal.</li> <li>2. Check if there is any foreign objects block dispensing slot.</li> </ol>
Continue Dispensing Cards after Power Applied (Hopper Mode)	<ol style="list-style-type: none"> <li>1. Make sure DIP Switch settings are correct.</li> <li>2. Check if dispensing signal is normal.</li> </ol>
Card Preparing Error	Re-adjust thickness of card. (Refer to 6-1)



**If the error can not be solved after corrective actions or happen again, please contact ICT for technical support.**

**ict** Taiwan

**International Currency Technologies Corporation**

No.28, Ln. 15, Sec. 6, Minguan E. Rd., Neihu Dist., Taipei City 114, Taiwan

sales@ictgroup.com.tw (For Sales)

fae@ictgroup.com.tw (For Customer Service)

Website: [www.ictgroup.com.tw](http://www.ictgroup.com.tw)

