

FOR GENERAL REFERENCE ONLY
Models shown may not match the
model features or manuf year of the
item offered by AERE.

PRODIGY
PLUS

C1030 - 1000lb Cube Ice Machine

Prodigy Plus® Modular Cube Ice Machine

The world's smartest cuber.

As the world's only self-monitoring cuber, the new Scotsman Prodigy Plus® cube ice machines make it easier than ever to maintain your equipment and save money. Whether it's the advanced ice level control or an optional feature board for quick diagnostics, this is ice-making re-imagined. And with intuitive technology like AutoAlert™ indicator lights, a reduced operational footprint and easy-access service from the front panel, Prodigy Plus® cubers are simply the smartest, most reliable way to create fresh-tasting ice — every time.



The Prodigy Plus® difference.

- AutoAlert™ indicator lights for better visibility
- Operational footprint among the industry's smallest
- Industry-exclusive QR code instantly connects users to service information and warranty history
- One-touch cleaning reduces labor costs and saves time
- Front-located air filter for more efficient operation
- Self-aligning front panel for easy access to key components
- Patented WaterSense purge control automatically reduces scale buildup
- Smart-Board™ advanced feature module available for additional diagnostic capabilities
- Optional Vari-Smart™ ice level control allows operators to customize ice levels
- Antimicrobial protection guards internal surfaces between cleanings
- A full range of water- and energy-saving features



B842S



B948S



24 Hour Volume Production

Air Cooled		Remote		Water Cooled	
70°F/21°C 50°F/10°C	Air Water	90°F/32°C 70°F/21°C	70°F/21°C 50°F/10°C	Air Water	90°F/32°C 70°F/21°C
1077/490 lb/kg		789/359 lb/kg	996/453 lb/kg	820/373 lb/kg	996/453 lb/kg



BH1100BB
BH1100SS



Modular Bin Options

Model Number*	Dimensions W" x D" x H"	Bin Application		Ship Weight lb/kg
		Capacity lb/kg	Finish	
B842S	42 x 34 x 44**	778/353	Metallic	190/86
B948S	48 x 34 x 44**	893/406	Metallic	209/95
BH1100BB	48 x 34 x 50**	1100/499	SS w/ GBB†	185/84
BH1100SS	48 x 34 x 50**	1100/499	Stainless Steel	280/127

* Contact Scotsman for bin top requirements. ** Add 6" Height for bin legs.
† Stainless steel with galvanized back & bottom.



Cube Ice

Common ice form, ideal for
mixed drinks.



Small Cube
7/8" x 7/8" x 3/8"
(2.22 x 2.22 x .95 cm)



Medium Cube
7/8" x 7/8" x 7/8"
(2.22 x 2.22 x 2.22 cm)



Certification



Warranty

- 3 years parts and labor on all components.
- 5 years parts and labor on the evaporator.
- 5 years parts on the compressor and condenser.
- Warranty valid in North, South & Central America for commercial installations.
- Contact factory for warranty in other regions.
- Residential Applications: 1 year parts and labor

Scotsman®

• 101 Corporate Woods Parkway, Vernon Hills, IL 60061 •
• 1-800-SCOTSMAN • Fax: 847-913-9844 • www.scotsman-ice.com • customer.relations@scotsman-ice.com •

C1030 - 1000lb Cube Ice Machine

C1030 - 1000lb Cube Ice Machine

Prodigy Plus® Modular Cube Ice Machine

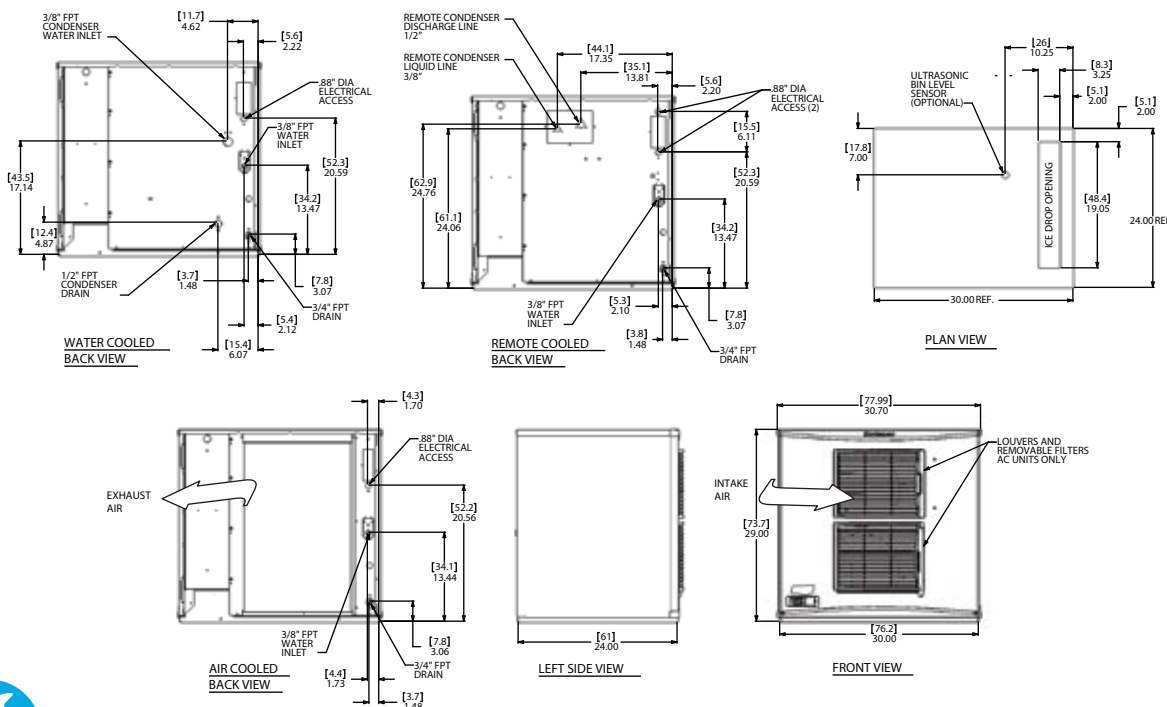

Specifications

Model Number	Condenser Unit	Basic Electrical Volts/Hz/Phase	Max. Fuse Size or HACR Circuit Breaker (amps)	Circuit Wires	Min. Circuit Ampacity	Energy Consumption kWh/100 lb (45.4 kg) 90°F(32°C)/70°F(21°C)	Water Usage Gallons/100 lb (liters/45.4 kg)	
							Potable 90°F(32°C)/70°F(21°C)	Condenser 90°F(32°C)/70°F(21°C)
med. C1030MA-32	Air	208-230/60/1	15	2	12.2	4.83	18.0/68.2	-
C1030MR-32	Remote	208-230/60/1	15	2	12.0	4.99	18.0/68.2	-
C1030MW-32	Water	208-230/60/1	15	2	11.0	4.04	18.0/68.2	134.0/508.1
C1030MR-3	Remote	208-230/60/3	15	3	9.6	4.99	18.0/68.2	-
sm. C1030SA-32	Air	208-230/60/1	15	2	12.2	4.83	18.0/68.2	-
C1030SR-32	Remote	208-230/60/1	15	2	12.0	4.99	18.0/68.2	-
C1030SW-32	Water	208-230/60/1	15	2	11.0	4.04	18.0/68.2	134.0/508.1
C1030SR-3	Remote	208-230/60/3	15	3	9.6	4.99	18.0/68.2	-



All Models

Dimensions (W x D x H):

Unit: 30" x 24" x 29"
(76.2 x 61.0 x 73.7 cm)

Shipping Carton: 33.5" x 27.5" x 34"
(85.1 x 69.9 x 86.4 cm)

Shipping Weight: 235 lb / 107 kg
BTUs per hour: 16,200

Refrigerant: R-404A



Accessories

Model Number	Description
KVS	Vari-Smart™ Ice Level Control - Program ice bin levels to match ice needs.
KSBU	Smart-Board™ Advanced Control - Use additional operational data for fast diagnosis.
KSBU-N	Smart-Board™ Advanced Control with Network - Network capable.
ERC311-32	Remote condenser for C1030xR, 208-230/60/1 - Consult remote condenser spec sheet for details
BRTE10	10ft (3.0 m) line set, brazing required
BRTE25	25ft (7.6 m) line set, brazing required
BRTE40	40ft (12.2 m) line set, brazing required
BRTE75	75ft (22.9 m) line set, brazing required
KPAS	Prodigy Advanced Sustainability Kit - Includes KVS and KSBU - N
KPPSA329	Prodigy Plus® Side Air Flow Kit for C0830 and C1030

Scotsman recommends all ice machines have water filtration. See Scotsman water filter specification sheet for details.



Operating Requirements

	Minimum	Maximum
Air Temperatures	50°F (10°C)	100°F (38°C)
Water Temperatures	40°F (4.4°C)	100°F (38°C)
Remote Cond. Temps	-20°F (-29°C)	120°F (49°C)
Water Pressures	20 PSIG (1.4 bar)	80 PSIG (5.5 bar)
Electrical Voltage	-5%	+10%

Specifications and design are subject to change without notice.

C1030 - 1000lb Cube Ice Machine