

Display Merchandiser Refrigerated Countertop model 4030GA

Description:

Self-contained counter-top display case with glass doors, top, and sides. Stainless steel interior and exterior. Randell bottom mounted refrigeration system with thermostatic control, system utilizes "CFC free", R-134a refrigerant. Foamed in place, "CFC free" insulation. (3) powder coated, angled display shelves and cordset for 115V plug-in operation.

Specifications:

CABINET EXTERIOR: Cabinet body to have all stainless steel surfaces with Self-closing insulated glass sliding doors at rear. Unit with solid glass top, front, and sides. Louver panel to be die-formed stainless steel, allowing ventilation of condensing unit.

CABINET INTERIOR: Interior to be all stainless steel with three, angled, powder coat finished shelves provided. Interior light is optional. Unit insulated with CFC free, foamed in place urethane insulation.

DOORS: Door to be insulated glass, nylon framed, and easily removed for cleaning or restocking.

REFRIGERATION: CFC free, R-134a bottom mounted refrigeration system with condensing unit, evaporator blower coil, automatic condensate evaporator, and thermostatic control for operator adjustability. Unit totally prewired and to be supplied with 8' cordset (NEMA 5-15P) for 115V plug-in operation.

Standard Features:

- Self-contained, bottom mounted refrigeration system with thermostatic control, system utilizes "CFC free", R-134a refrigerant
- Insulated sliding glass doors in rear, with glass front, top, and sides
- Stainless steel exterior and interior surfaces
- Foamed in place CFC free, urethane insulation
- Condensate evaporator
- Thermostatic control for easy temperature adjustment
- Three powder coated, angled display shelves

Options & Accessories:

- Interior light
- 4" high legs
- Fluorescent lights

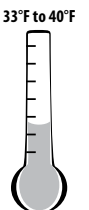

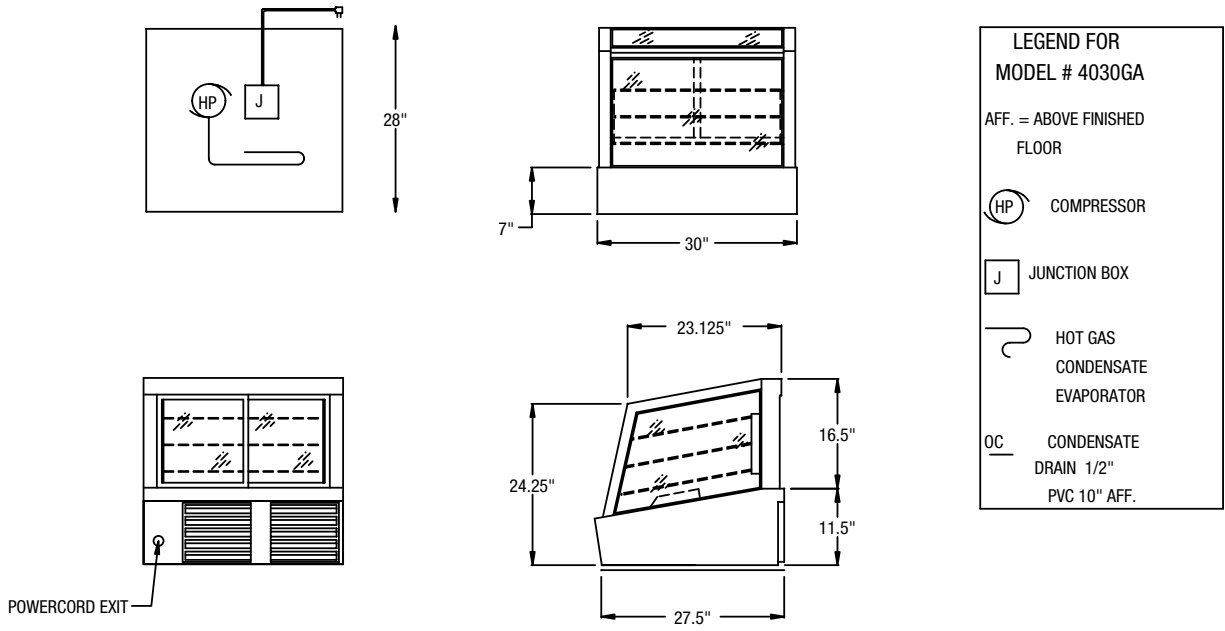

Drawings are to be viewed in the same order as the chart

Unit Length	Door Opening Sizes - Interior Depths		Interior Depth Behind Sliding Glass Door
	Clearances Through Door Lt. to Rt.	Clearances Through Door Top to Bottom	
30"	9 1/2"	13 1/2"	23" max. 21" min.

Model	L	D	H	Style	No. of Shelves	Storage Cu. Ft.	H.P.	Volt	Amp.	NEMA	Ship Wt.
4030GA	30"	27.5"	28"	Counter top	3	5.3	1/4	115/60/1	5.0	5-15P	240